

Moreover, every kind of blasting requires a dedicated procedure of destruction and this operation is always carried out at the end of the shift, when the level of attention of the workers is decreasing.



*Figures 5.4 and 5.5: Different explosives*

### 5.2.2 The accidents investigated

The accidents investigated are characterised by some common failures and they show several important **lacks in the Risk Assessment and Management**. Following is one of these fatalities described in order to identify the aforesaid failures.

First of all, **the blasting agents were destroyed together, in an incorrect way and all at the same time**. As a matter of fact the explosives (detonators, gun powder etc...) were burned together in a metal tank; this operation surely led to an unwanted detonation caused by the extreme amount of materials.



*Figures 5.6 and 5.7: Parts of the metal tank ripped by the explosion which were found stuck in the boot of the victim*



In the second instance, **a correct procedure wasn't planned** for destroying the unused materials. Every explosive has to be destroyed with a correct procedure in order to avoid any detonation or unwelcome results.

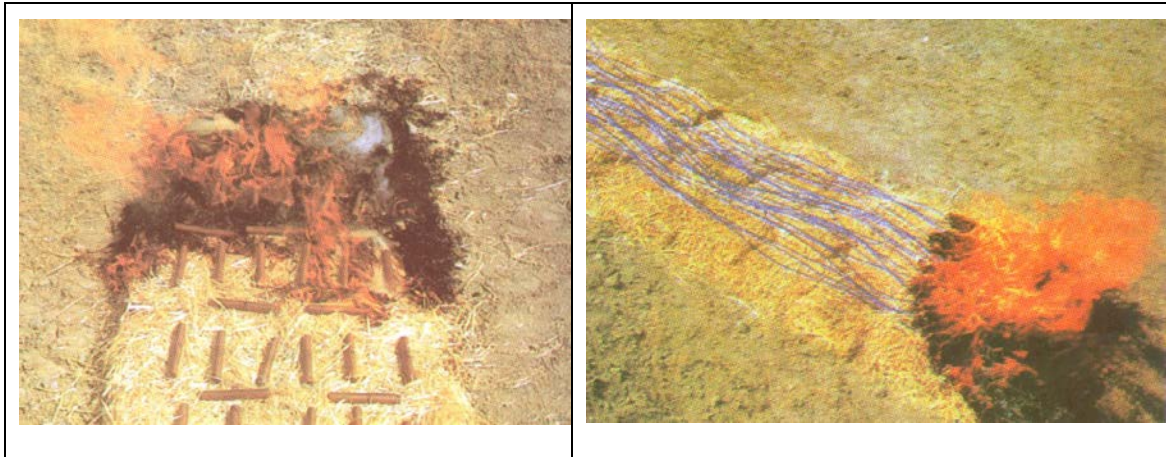

*Figure 5.8 and 5.9: the correct procedure to destroy the gun powder and the detonating cord*



During the aforesaid incorrect destroying operations, next to the exploded tank **were some workers that were trying to warm themselves by the fire.**

The presence of these workers surely aggravated the accident since it led to the involvement of other three workers.



And, finally the operations were led **at the end of the work shift**, with a **very low level of attention** caused possibly by the **cold weather** and the **hurry** to complete the job.

This afterwards analysis carried out to identify the root causes of the accident is based on the aforesaid “computer assisted technique”; the aim is to avoid the same situation to present itself again by learning from the mistakes.

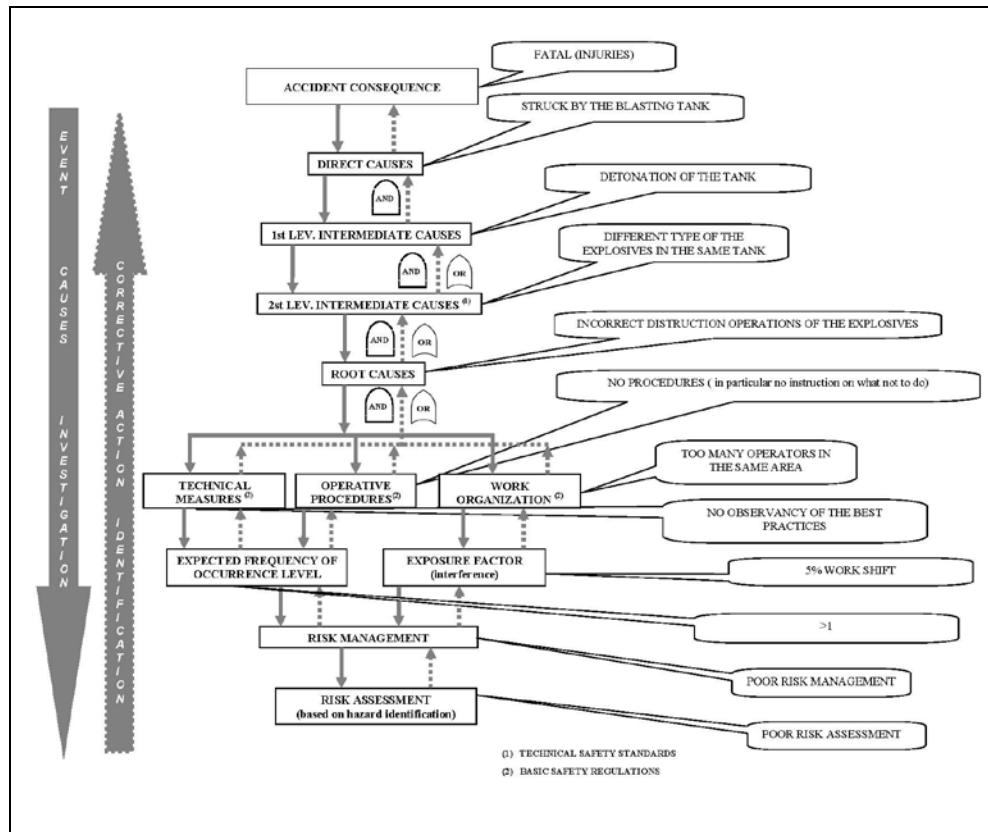

Figure 5.10: The flow-chart on which is based the “computer assisted technique”

### 5.3 FINAL CONSIDERATION FOR A CORRECT WORK SHIFT MANAGEMENT

Existing knowledge about the extent, nature, and effects of shift work allows several general points to be underlined. Firstly, for better or worse, shift work is here to stay. The healthcare, supply of food, and power generation or other industrial plant where it is impossible to stop the productive cycle (cement or glass factory) will always be required 24 hours a day. Secondly, to provide continuous cover some form of shift system must be employed. This often results in disruption to the worker because it conflicts with our evolutionary development as diurnal creatures (primarily active during the day, inactive at night). Thirdly, a shift system can have a considerable impact on the people having to work it. As said in previous paragraphs, this impact may manifest itself in terms of sleep, health, and social disruption, as well as on job performance, Safety and level of attention during his operation. Fourthly, these potential effects of shift work will depend to varying degrees on the nature of the job and of the worker.

1. sedentary operation (monitoring of a control panel);
2. active physical work personal characteristics of the individual;

3. a favourable predisposition to night work;
4. effective coping skills and features of the system worked (direction and speed of rotation, duration of shifts, and number of consecutive shifts of the same kind).

For these reason a careful and exhaustive analysis of the entire productive cycle is always requested in order to correctly plan the different operations and shift work and to conserve an high level of attention of the workers during all the time of the operation.

## References

- Cardu M., Martinetti A., Patrucco M, 2011, The correct method to destroy the blasting agents - Training Day at the Mining Inspector Authority, [http://www.provincia.torino.gov.it/ambiente/filestorage/download/attivita\\_estrattiva/pdf/giornata\\_studio\\_2011-06-30.pdf](http://www.provincia.torino.gov.it/ambiente/filestorage/download/attivita_estrattiva/pdf/giornata_studio_2011-06-30.pdf).
- Fischer F.M., Moreno CRC, Fernandez RL, 1993, Day and shiftworkes' leisure time, *Ergonomics*, 36, 43–9.
- Folkard S, Monk T.,1985, Hours of work: temporal factors in work scheduling, Wiley: Chichester.
- Queensland Mines and Quarries Safety Performance and Health Report 2010-2011
- Volger A, Ernst G, Nachreiner F, 1988, Common free time of family members under different shift systems. *Applied Ergonomics*,19:213–8.
- Waterhouse J, Folkard S, Minors D. Shiftwork, 1992, Health and Safety: an over view of the scientific literature, HMSO.



*Contents*

*Start of the  
Chapter*



# CHAPTER 6: ITERATIVE OPERATIONS

## *THE PREVENTION FOR MINERS' HEALTH*

*“Does the flap of a butterfly's wings in Brazil set off a tornado in Texas?”*

*Edward Lorenz*

### **THE PROBLEM: how can we improve the miners' health in iterative operations?**

Mining and quarrying – and particular underground mining and quarrying, as the data have confirmed in the previous chapters, are more hazardous in many respects, closely connected with noise, segmental vibration, heat, barometric pressure changes, ionizing radiation and airborne dust, than most other major industries and continual and increasing attention should be given to its health aspects.

Moreover, as already discussed, mining and quarrying involve unavoidable and calculated risks, as in all facets of live. It is most important then that men employed in mining and quarrying be schooled (properly formed and trained) in the hazards and develop fully the ability to evaluate and minimise risks.

The underground environment often is harsh and strange, compared to the more natural surface conditions

### **6.1 NOISE**

Noise is ubiquitous in mining. It is generated by powerful machines, fans, blasting and transportation of the ore. The underground mine usually has limited space and thus creates a reverberant field. Noise exposure is greater than if the same sources were in a opencast environment.

Exposure to noise can be reduced by using conventional means of noise control on mining machinery. Transmissions can be quieted, engines can be muffled better, and

hydraulic machinery can be quieted as well. Chutes can be insulated or lined with sound-absorbing materials. Hearing protectors combined with regular audiometric testing are often necessary to preserve miners' hearing. But most of times it's not enough. *In any case, the protectors shouldn't be considered as the winning solution to reduce workers' exposure to the hazards.*

## **6.2 IONIZING RADIATION**

Ionizing radiation is a hazard in the mining industry. Radon can be liberated from stone while it is loosened by blasting, but it may also enter a mine through underground streams. It is a gas and therefore it is airborne. Radon and its decay products emit ionizing radiation, some of which have enough energy to produce cancer cells in the lungs. As a result, death rates from lung cancer among uranium miners are elevated. For miners who smoke, the death rate is much higher.

## **6.3 HEAT**

Heat is a hazard for both underground and surface miners. In underground mines, the principal source of heat is from the rock itself. The temperature of the rock goes up about 1 °C for every 100 m in depth. Other sources of heat stress include the amount of physical activity the workers are doing, the amount of air circulated, the ambient air temperature and humidity and the heat generated by mining equipment, principally diesel powered equipment. Very deep mines (deeper than 1,000 m) can pose significant heat problems, with the temperature of mine ribs of about 40 °C. For surface workers, physical activity, the proximity to hot engines, air temperature, humidity and sunlight are the principal sources of heat.

Reduction of heat stress can be accomplished by cooling high temperature machinery, limiting physical activity and providing adequate amounts of potable water, shelter from the sun and adequate ventilation. For surface machinery, air-conditioned cabs can protect the equipment operator. In the deep mines in South Africa, for example, underground air-conditioning units are used to provide some relief, and first aid supplies are available to deal with heat stress.

## **6.4 HIGH ALTITUDES**

Many mines operate at high altitudes (e.g., greater than 1,000 m), and because of this, miners may experience altitude sickness. This can be aggravated if they travel back and forth between a mine at a high altitude and a more normal atmospheric pressure.



It is known that, the airborne hazards in the mining industry include several types of particulates, naturally occurring gases, engine exhaust and some chemical vapours. These occur in different combinations depending on the mine or quarry, its depth, the composition of the ore and surrounding rock, and the method(s) of mining. Among some groups of miners who live together in isolated locations, there is also risk of transmitting some infectious diseases such as tuberculosis, hepatitis (B and E), and the human-immunodeficiency virus (HIV). Miners' exposure varies with the job, its proximity to the source of hazards and the effectiveness of hazard control methods.

## **6.5 AIRBORNE DUST**

### **6.5.1 Free crystalline silica**

Among the Airborne Particulate Hazards, the free crystalline silica is the most abundant compound in the earth's crust and, consequently, it is the most common airborne dust that miners and quarry-workers have to face. Free silica is silicon dioxide which is not chemically bonded with any other compound as a silicate. The most common form of silica is quartz although it can also appear as tridymite or cristobalite. Respirable particles are formed whenever silica-bearing rock is drilled, blasted, crushed or otherwise pulverized into fine particles. The amount of silica in different species of rock varies but is not a reliable indicator of how much respirable silica dust may be found in an air sample. It is not uncommon, for example, to find 30% free silica in a rock but 10% in an air sample, and vice versa. Sandstone can be up to 100% silica, granite up to 40%, slate 30%, with lesser proportions in other minerals. Exposure can occur in any mining operation, surface or underground, where silica is found in the overburden of a surface mine or the ceiling, floor or ore deposit of an underground mine. Silica can be dispersed by the wind, by vehicular traffic or by earth-moving machinery.

In the 2010 the A.C.G.I.H. (*American Conference of Governmental Industrial Hygienists*) identified a new TLV-TWA for silica exposure of 0,025 mg/m<sup>3</sup>, reducing it by 50%.

The silica can cause silicosis, a typical pneumoconiosis that develops insidiously after years of exposure. Exceptionally high exposure can cause acute or accelerated silicosis within months with significant impairment or death occurring within a few years. Exposure to silica is also associated with an increased risk of tuberculosis, lung cancer and of some autoimmune diseases, including scleroderma, systemic lupus erythematosus and rheumatoid arthritis. Freshly fractured silica dust appears to be more reactive and

more hazardous than old or stale dust. This may be a consequence of a relatively higher surface charge on freshly formed particles.

The most common processes that produce respirable silica dust in mining and quarrying are drilling, blasting and cutting silica-containing rock. Most holes drilled for blasting are done with an air powered percussion drill mounted on a tractor crawler. The hole is made with a combination of rotation, impact and thrust of the drill bit. As the hole deepens, steel drill rods are added to connect the drill bit to the power source. Air not only powers the drilling, it also blows the chips and dust out of the hole which, if uncontrolled, injects large amounts of dust into the environment. The hand-held jack-hammer or sinker drill operates on the same principle but on a smaller scale. This device conveys a significant amount of vibration to the operator and with it, the risk of vibration white finger. Vibration white finger has been found among miners in India, Japan, Canada and elsewhere. The track drill and the jack-hammer are also used in construction projects where rock must be drilled or broken to make a highway, to break rock for a foundation, for road repair work and other purposes.

Dust controls for these drills have been developed and are effective. A water mist, sometimes with a detergent, is injected into the blow air which helps the dust particles to coalesce and drop out. Too much water results in a bridge or collar forming between the drill steel and the side of the hole. These often have to be broken in order to remove the bit; too little water is ineffective. Problems with this type of control include reduction in the drilling rate, lack of reliable water supply and displacement of oil resulting in increased wear on lubricated parts.

The other type of dust control on drills is a type of local exhaust ventilation. Reverse air-flow through the drill steel withdraws some of the dust and a collar around the drill bit with ductwork and a fan to remove the dust. These perform better than the wet systems described above: drill bits last longer and the drilling rate is higher. However, these methods are more expensive and require more maintenance.

Other controls that provide protection are cabs with filtered and possibly air-conditioned air supply for drill operators, bulldozer operators and vehicle drivers. The appropriate respirator, correctly fitted, may be used for worker protection as a temporary solution or if all others prove to be ineffective.

Silica exposure also occurs at stone quarries that must cut the stone to specified dimensions. The most common contemporary method of cutting stone is with the use of a channel burner fuelled by diesel fuel and compressed air. This results in some silica



particulate. The most significant problem with channel burners is the noise: when the burner is first ignited and when it emerges from a cut, sound level can exceed 120 dB(A). Even when it is immersed in a cut, noise is around 115 dB(A). An alternative method of cutting stone is to use very high-pressure water.

Often attached to or nearby a stone quarry is a mill where pieces are sculpted into a more finished product. Unless there is very good local exhaust ventilation, exposure to silica can be high because vibrating and rotating hand tools are used to shape the stone into the desired form.

An important research work in order to reduce the incidence of silica dust both during the extraction and the secondary stone processing was carried out by the NIS (Network Italiano Silice).



*Figure 6.1: The Italian Network on the Silica*

The aim of the work was on one hand to identify the different operations which characterized the productive and technological cycle of the stone and on the other hand to evaluate the right effectiveness of the prevention and protection actions and procedures taken place in the different extractive sites and laboratories.

On the basis of the technological cycle, every single operation was analysed and, in order to make the use of the obtained information easier, the identification of free crystalline silica sources was connected to the solutions suggested.

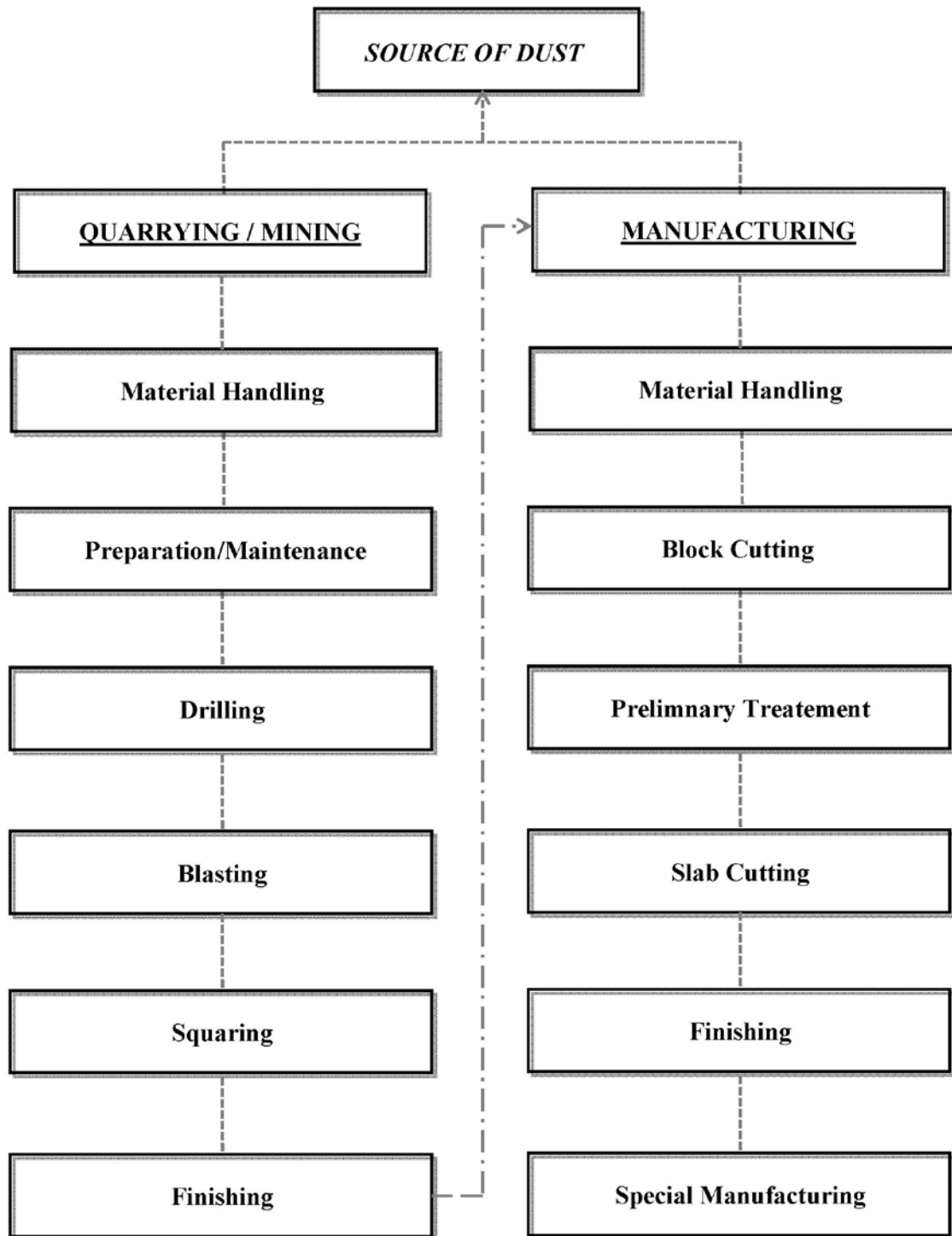

Figure 6.2: Flow Chart of the technological cycle of the stone starting from the quarrying up to the manufacturing

The working group underlined that in the analysed scenarios two different kinds of airborne dust can be identified; the first one is the "primary airborne dust", produced and dispersed in the atmosphere due to the mechanical stresses impressed by machines and equipment to the rock, and the second one is produced due to the action of wind and moving means, increased by the part of dust naturally present on the ground or settled on surfaces (floors, plants, and semi-finished products) as a direct

effect of previous machining operations. In the Figure 6.2 are briefly described the main possible sources of dust that should be taken into account to reduce the exposure of the workers during these operations.

In the left column of Figure 6.2 the operations related to the quarry /mining activities are described; in the right column, furthermore, the main operations related to the stone-shope are highlighted.

### **6.5.2 Coal mine dust**

Respirable coal mine dust is a hazard in underground and surface coal mines and in coal-processing facilities. It is a mixed dust, consisting mostly of coal, but which can also include silica, clay, limestone and other mineral dusts. The composition of coal mine dust varies with the coal seam, the composition of the surrounding strata and mining methods. Coal mine dust is generated by blasting, drilling, cutting and transporting coal.

More dust is generated by mechanized mining than by manual methods, and some methods of mechanized mining produce more dust than others. Cutting machines that remove coal with rotating drums studded with picks are the principal sources of dust in mechanized mining operations. These include so-called continuous miners and longwall mining machines. Longwall mining machines usually produce larger amounts of dust than other methods of mining do. Dust dispersion can also occur with the movement of shields in longwall mining and with the transfer of coal from a vehicle or conveyor belt to some other mean of transport.

Coal mine dust causes coal workers' pneumoconiosis (CWP) and contributes to the occurrence of chronic airways disease such as chronic bronchitis and emphysema. Coal of high rank (e.g., high carbon content such as anthracite) is associated with a higher risk of CWP. There are some rheumatoid-like reactions to coal mine dust as well.

The generation of coal mine dust can be reduced by changes in coal cutting techniques and its dispersion can be controlled with the use of adequate ventilation and water sprays. If the speed of rotation of cutting drums is reduced and the tram speed (the speed with which the drum advances into the coal seam) is increased, dust generation can be reduced without losses in productivity. In longwall mining, dust generation can be reduced by cutting coal in one pass (rather than two) across the face and tramping back without cutting or by a clean-up cut. Dust dispersion on longwall sections can be reduced with homotropical mining (i.e., the chain-conveyor at the face, the cutter head

and the air all travelling in the same direction). A novel method of cutting coal, which consists in using an eccentric cutter head that continuously cuts perpendicular to the grain of a deposit, seems to generate less dust than the conventional circular cutting head.

Adequate mechanical ventilation flowing first over a mining crew and then to and across the mining face, can reduce exposure. Auxiliary local ventilation at the working face, using a fan with ductwork and scrubber, can also reduce exposure by providing local exhaust ventilation.

Water sprays, strategically placed close to the cutterhead and forcing dust away from the miner and towards the face, also assist in reducing exposure. Surfactants provide some benefit in reducing the concentration of coal dust.

Asbestos exposure occurs among asbestos miners and in other mines where asbestos is found in the ore. Among miners throughout the world, exposure to asbestos has elevated the risk of lung cancer and of mesothelioma. It has also elevated the risk of asbestosis (another pneumoconiosis) and of airways disease.

Diesel engine exhaust is a complex mixture of gases, vapours and particulate matter. The most hazardous gases are carbon monoxide, nitrogen oxide, nitrogen dioxide and sulphur dioxide. There are many volatile organic compounds (VOCs), such as aldehydes and unburned hydrocarbons, polycyclic aromatic hydrocarbons (PAHs) and nitro-PAH compounds (N-PAHs). PAH and N-PAH compounds are also adsorbed onto diesel particulate matter. Nitrogen oxides, sulphur dioxide and aldehydes are all acute respiratory irritants. Many of the PAH and N-PAH compounds are carcinogenic.

Diesel particulate matter consists of small diameter (<1 µm in diameter) carbon particles that are condensed from the exhaust fume and often aggregate in air in clumps or strings. These particles are all respirable. Diesel particulate matter and other particles of similar size are carcinogenic in laboratory animals and appear to increase the risk of lung cancer in exposed workers at concentrations above about 0.1 mg/m<sup>3</sup>. Miners in underground mines experience exposure to diesel particulate matter at significantly higher levels. The International Agency for Research on Cancer (IARC) considers diesel particulate matter to be a probable carcinogen.

The generation of diesel exhaust can be reduced by engine design and with high-quality, clean and low-sulphur fuel. De-rated engines and fuel with a low cetane number and low sulphur content produce less particulate matter. Use of low sulphur fuel reduces the generation of SO<sub>2</sub> and of particulate matter. Filters are effective and feasible and can

remove more than 90% of diesel particulate matter from the exhaust stream. Filters are available for engines without scrubbers and for engines with either water or dry scrubbers. Carbon monoxide can be significantly reduced with a catalytic converter. Nitrogen oxides form whenever nitrogen and oxygen are under conditions of high pressure and temperature (i.e., inside the diesel cylinder) and, consequently, they are more difficult to eliminate.

The concentration of dispersed diesel particulate matter can be reduced in an underground mine by adequate mechanical ventilation and restrictions on the use of diesel equipment. Any diesel powered vehicle or other machine will require a minimum amount of ventilation to dilute and remove the exhaust products. The amount of ventilation depends on the size of the engine and its uses. If more than one diesel powered piece of equipment is operating in one air course, ventilation will have to be increased to dilute and remove the exhaust.

Diesel powered equipment may increase the risk of fire or explosion since it emits a hot exhaust, with flame and sparks, and its high surface temperatures may ignite any accumulated coal dust or other combustible material. Surface temperature of diesel engines have to be kept below 305° F (150° C) in coal mines in order to prevent the combustion of coal. Flame and sparks from the exhaust can be controlled by a scrubber to prevent ignition of coal dust and of methane.

## **6.6 GASES AND VAPOURS**

Table 6.3 lists gases commonly found in mines. The most important naturally occurring gases are methane and hydrogen sulphide in coal mines and radon in uranium and other mines. Oxygen deficiency is possible in either. Methane is combustible. Most coal mine explosions result from ignitions of methane and are often followed by more violent explosions caused by coal dust that has been suspended by the shock of the original explosion. Throughout the history of coal mining, fires and explosions have been the principal cause of death of thousands of miners. Risk of explosion can be reduced by diluting methane to below its lower explosive limit and by prohibiting potential ignition sources in the face areas, where the concentration is usually the highest. Dusting the mine ribs (wall), floor and ceiling with incombustible limestone (or other silica-free incombustible rock dust) helps to prevent dust explosions; if dust suspended by the shock of a methane explosion is not combustible, a secondary explosion will not occur.

Gas	Common name	Health effects
Methane (CH <sub>4</sub> )	Fire damp	Flammable, explosive; simple asphyxiation
Carbon monoxide (CO)	White damp	Chemical asphyxiation
Hydrogen sulphide (H <sub>2</sub> S)	Stink damp	Eye, nose, throat irritation; acute respiratory depression
Oxygen deficiency	Black damp	Anoxia
Blasting by-products	After damp	Respiratory irritants
Diesel engine exhaust	Same	Respiratory irritant; lung cancer

*Table 6.3: Common names and health effects of hazardous gases occurring in coal mines*

Radon is a naturally occurring radioactive gas that has been found in uranium mines, tin mines and some other mines. It has not been found in coal mines. The primary hazard associated with radon is its being a source of ionizing radiation, which is discussed below.

Other gaseous hazards include respiratory irritants found in diesel engine exhaust and blasting by-products. Carbon monoxide is found not only in engine exhaust but also as a result of mine fires. During mine fires, CO can reach not only lethal concentrations but also can become an explosion hazard.

Nitrogen oxides (NO<sub>x</sub>), primarily NO and NO<sub>2</sub>, are formed by diesel engines and as a by-product of blasting. In engines, NO<sub>x</sub> are formed as an inherent by-product of putting air, 79% of which is nitrogen and 20% of which is oxygen, under conditions of high temperature and pressure, the very conditions necessary to the functioning of a diesel engine. The production of NO<sub>x</sub> can be reduced to some extent by keeping the engine as cool as possible and by increasing ventilation to dilute and remove the exhaust.

NO<sub>x</sub> is also a blasting by-product. During blasting, miners are removed from an area where blasting will occur. The conventional practice to avoid excessive exposure to nitrogen oxides, dust and other results of blasting is to wait until mine ventilation removes a sufficient amount of blasting by-products from the mine before re-entering the area along an intake airway.

Oxygen deficiency can occur in many ways. Oxygen can be displaced by some other gas, such as methane, or it may be consumed either by combustion or by microbes in an air space with no ventilation.

There is a variety of other airborne hazards to which particular groups of miners are exposed. Exposure to mercury vapor, and thus risk of mercury poisoning, is a hazard among gold miners and millers and among mercury miners. Exposure to arsenic, and to

the risk of lung cancer, occurs among gold miners and lead miners. Exposure to nickel, and thus to the risk of lung cancer and skin allergies, occurs among nickel miners.

Some plastics are being used in mines also. These include urea-formaldehyde and polyurethane foams, both of which are plastics made in-place. They are used to plug up holes and improve ventilation and to provide a better anchor for roof supports. Formaldehyde and isocyanides, two starting materials for these two foams, are respiratory irritants and both can cause allergic sensitization making it nearly impossible for sensitized miners to work around either ingredient. Formaldehyde is a human carcinogen (IARC Group 1).

*It should be noted that most occupational illness arise from the inhalation of airborne particles or toxic gases. For this reason, the mineral industry has given much attention to the control of airborne illness-producing contaminants. As briefly illustrated in the previous paragraphs, a particular attention was focused of those diseases of the lung resulting from prolonged inhalation of such minerals as silica, coal dust, or asbestos fibers. Such diseases, often termed silicosis, coal workers' pneumoconiosis or asbestosis (or more generally termed pneumoconiosis), were long the scourge of these employed in the mineral industry. The dust remaining within the lungs may cause fibrotic changes which are symptomatically indicated by shortness of breath, coughing and general debility.*



## References

- Cummins A., Given I., 1973, SME – Mining Engineering Handbook, Volume 1, The American Institute of Mining, metallurgical and Petroleum Engineers, Inc, New York.
- Erdogdu G, Hasirci V, 1998. An overview of the role of mineral solubility in silicosis and asbestosis. Environ Res 78:38–42.
- IARC, Monographs on the Evaluation of the Carcinogenic Risk of Chemical to Humans. Silica, Some Silicates, Coal Dust and Para-aramid Fibrils, 1997.
- IARC, Overall evaluation of carcinogenicity: an updating of IARC monographs volumes 1 to 42, 1987.
- Heppleston AG, 1994. Pathogenesis of mineral pneumoconioses. In: Parkes WR, ed. Occupational lung disorders. 3rd ed. London: Butterworth-Heinemann Publishers, pp. 100–134.
- HSE, 2009. “Health and safety Statistics 2008/09”. A National Statistics publication
- NIOSH, 2002. Hazard review - Health Effects of Occupational Exposure to Respirable Crystalline Silica, DHHS (NIOSH) Publication
- NIOSH, 2004, Department of Health and Human Services - Centers for Disease Control and Prevention, Worker Health Chart Book.
- NIS – Network Italiano Silice, 2007. Valutazione del rischio – Documento di linee guida per la valutazione dell'esposizione professionale a silice libera cristallina.



*Contents*

*Start of the  
Chapter*



## CHAPTER 7: THE HAZARD IDENTIFICATION TECHNIQUES APPLIED IN MINING PLANTS

*Sono gli interessi (materiali e ideali), e non le idee, a dominare immediatamente l'agire dell'uomo. Ma le "concezioni del mondo", create dalle "idee", hanno spesso determinato – come chi aziona uno scambio ferroviario – i binari lungo i quali la dinamica degli interessi ha mosso tale attività.*

*Max Weber*

**THE PROBLEM: is it correct to wonder which is the best Hazard Identification technique?**

The purpose of this chapter is to summarise important aspects of the Hazard Identification techniques in order to adopt the most suitable one for each different situation.

Several of the techniques discussed in this chapter are appropriately used for performing general process hazard studies –usually at the early stages of the life of a process (e.g., Safety Review, Checklist analysis, PHA and What-If Analysis); these are very efficient at taking a “broad-brush” look at the inherent hazards or at giving a simple tool to the workers / maintenance units to know how risks have to be faced.

On the contrary, other techniques are suitable to lead deep analysis during the design phase of the process and during the maintenance operations (e.g., Checklist/What-If Analysis, HAZOP Analysis, and FMEA); moreover they are also useful to outline hazardous situations which can be analysed in depth with more sophisticated techniques.

Finally there are a group of techniques (Fault Tree Analysis, Event Tree Analysis, Cause/Root-Consequences Analysis, Human Reliability Analysis, Ishikawa Analysis...) which should be only applied in particular situation due to:

- the detailed information required to provide a good result;
- specially trained and skilled analyst;
- significant more time and effort to perform.

## **7.1 CONFOUNDING FACTORS IN THE HAZARD IDENTIFICATION DECISION MAKING**

It should be noted that the process Safety is affected by different aspects such as the use of appropriate technology during the planning and construction phase, external circumstances, the human behavior and the effective management systems. For these reasons, selecting the most appropriate Hazard Identification method is **one of the most critical steps in a Risk Analysis**.

In order to make the proper choice of a technique, it is fundamental to understand the parameters on which the study is based: the motivation of study, the type of results needed, the type of information available to perform the study, the characteristic of the analysis problem, the perceived risk associated with both the workers and the external environment.

First of all, the motivation of study and the results needed should be the very first aspects taken into account during this phase; the accuracy of the approach, according to the goal, has to be considered in order not to over/underestimate the possible hazards and not to misunderstand the organisation's risk management needs.

*Will the study be carried on to accomplish legal requirements? Or will be the study carried on as a part of a global improvement of the system for the Safety?*

Since every Hazard Identification technique requires a wide amount of resources, such as human, technical and physical, the analyst should carefully inquire the level and the quality of the results obtainable in order to minimise the waste of time and useless loss of money.

Obviously, the type of information available, the characteristics of the analysis problem and the perceived risk affect the choice of the Hazard Identification technique according to the quality of the starting available information and according to the stage of the

activity or the process at which the study is performed. As a numerical simulation is more accurate when there is quite good initial data, so is the Hazard Identification more effective in reducing the occupation risk; the analyst should never expect, and never provide, a result more accurate than the initial information!

Nevertheless, it is particularly important that the selected level of resolution is compatible with the purpose of the study; if the facility needed to be analysed is rather large, maybe it should be better to carry on a preliminary simple technique to screen the principal hazards, to then divide the system or the equipment in sublevels studied by more efficient methods.

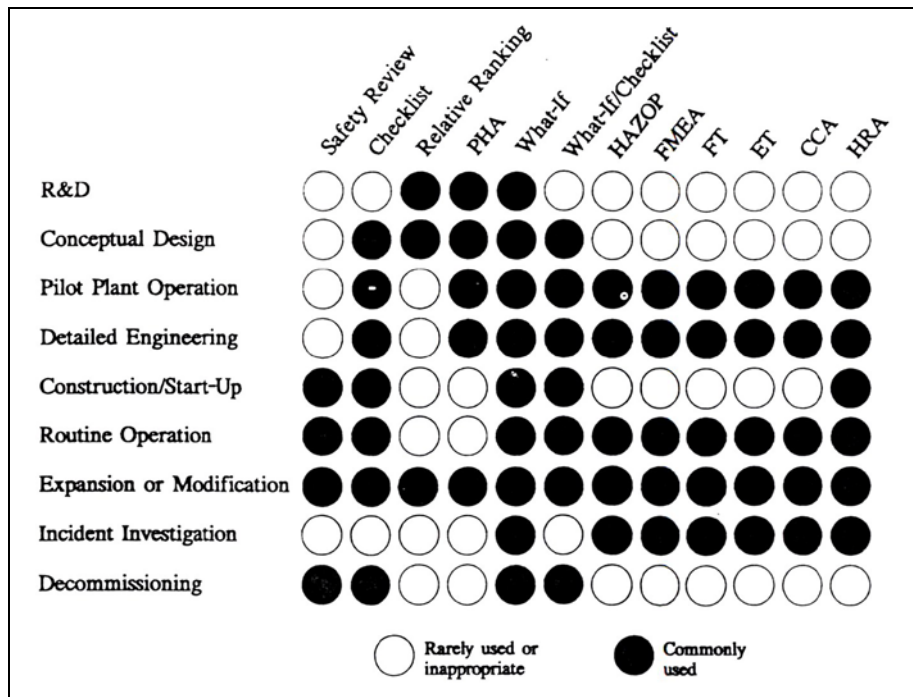

Figure 7.1: Common uses for these Hazard Identification techniques.<sup>10</sup>

In a similar way, the type of process and the type of operations have to be taken in great consideration due to their features in relation with the capacity of the different techniques; regarding this aspect, it should be noted that the FMEA method (Failure Modes and Effects Analysis) analyses more efficiently the problems related to the electronic and computer equipments than the HAZOP method (Hazard Operability).

Finally, it is important to be aware that even though the entire Hazard Identification analysis is properly carried out at every level, unfortunately, studies will never be flawless, will never guarantee the identification of all possible situations. But this permanent condition has to be faced, on one hand by involving a multidisciplinary team

<sup>10</sup> “Guidelines for Hazard Evaluation Procedures – second edition with worked examples”

with different experience during the planning phase of the system or during the preliminary study, and on the other hand by using more systematic techniques for the situations that could produce the accidents expected to have severe consequences.

All of these factors contribute to the level of confidence, attention or concern that an Organisation has on the possible risks; it is quite common that, if a process or an equipment is fairly new or relatively free of accidents for a long time, the potential risk is perceived less and the chosen Hazard Identification techniques could be those less exhaustive, precise and more-experienced based.

Technique	Phase of HE Study							
	Preparation		Modeling		Evaluation		Documentation	
	Simple/Small System	Complex/Large Process	Simple/Small System	Complex/Large Process	Simple/Small System	Complex/Large Process	Simple/Small System	Complex/Large Process
Safety Review	2 to 4h <sup>d</sup>	1 to 3d	na	na	4 to 8h	3 to 5d	4 to 8h	3 to 6d
Checklist Analysis	2 to 4h	1 to 3d	na	na	4 to 8h	3 to 5d	4 to 8h	2 to 4d
Relative Ranking	2 to 4h	1 to 3d	na	na	4 to 8h	3 to 5d	4 to 8h	3 to 5d
PHA	4 to 8h	1 to 3d	na	na	1 to 2d	4 to 7d	1 to 2d	4 to 7d
What-If Analysis	4 to 8h	1 to 3d	na	na	4 to 8h	3 to 5d	1 to 2d	1 to 3w
What-If/ Checklist Analysis	6 to 12h	1 to 3d	na	na	6 to 12h	4 to 7d	4 to 8h	1 to 3w
HAZOP Analysis	8 to 12h	2 to 4d	na	na	1 to 3d	1 to 3w	2 to 6d	2 to 6w
FMEA	2 to 6h	1 to 3d	na	na	1 to 3d	1 to 3w	1 to 3d	2 to 4w
Fault Tree Analysis	1 to 3d	4 to 6d	3 to 6d	2 to 3w	2 to 4d	1 to 4w	3 to 5d	3 to 5w
Event Tree Analysis	1 to 2d	4 to 6d	1 to 3d	1 to 2w	1 to 2d	1 to 2w	3 to 5d	3 to 5w
Cause-Consequence Analysis	1 to 2d	4 to 6d	1 to 3d	1 to 2w	1 to 3d	1 to 2w	3 to 5d	3 to 5w
Human Reliability Analysis	4 to 8h	1 to 3d	1 to 3d	1 to 2w	1 to 2d	1 to 2w	3 to 5d	1 to 3w

<sup>a</sup> h=hours, d=days, w=weeks, m=months, and na=not applicable.

Figure 7.2: Summary of typical staff effort estimates for Hazard Identification techniques.<sup>11</sup>

The subdivision between “Simple/Small” and “Complex/Large” systems was created to roughly estimate the amount of time that should be spent in every phase of the study for each technique. For example, a “Simple/Small” system could be represented by a chemical unloading and storage or a rail car unloading station, transfer lines, pumps, single equipments etc...On the other side a “Complex/Large” system could be represented by a chemical reaction process, including product separation, recovery and emergency relief system and associated control system. This process may contain a huge number of different vessels, reactors etc...

<sup>11</sup> “Guidelines for Hazard Evaluation Procedures – second edition with worked examples”

## **7.2 THE APPLICATION OF DUE DIFFERENT HAZARD IDENTIFICATION TECHNIQUES IN MINING ACTIVITIES**

As mentioned above, a Hazard Identification technique suitable for every situation and for every system does not exist; for these reasons the very first thing that should be done by an analyser, is to identify which results to pursue and the facilities involved.

Below, three different kind of Hazard Identification techniques are shown and applied to three different systems; the results that are obtained, as just said above, are related to the features of the technique, to the complexity of the system and to the purpose requested.

### **7.2.1 HAZOP (HAZard and OPerability analysis) applied to the sand drying plant**

The purpose of HAZOP is to identify all possible situations from which an hazardous event can be originated in terms of Safety or an operating problem of the plant with consequent unscheduled stop of productivity. The technique is extremely analytical and it can achieve a high level of detail by using a protocol analysis which is characterised by a high completeness and by a systematic *Modus Operandi*.

The collection of data is characterised by:

- ★ well cared information phase to obtain all data of the project and of the plant management;
- ★ precise and explicit goals of the study.

The onsite collection of information data was followed by the choice of the goals to be pursued. The purpose of the analysis (decided in agreement with the Management) was to identify the unscheduled and fault situations that lead to:

- Top Event 1: emissions in the workplace;
- Top Event 2: emissions out of the workplace through the chimney.

The next step in data collection was the definition of the sub-level of study, related to the different and defined areas of the system by identifying nodes, corresponding to the sections of the system.

The following charts and diagrams are produced:

- functional block diagram;
- flow diagram of the system with partition into two identified sub-systems and with an indication of the nodes analysed;
- list of symbols;
- starting operating conditions;
- analysis of operability;
- diagram of the accident sequences TE 1;
- diagram of the accident sequences TE 2.

A recursive analysis of operability was applied, by identifying deviation by deviation, in order to methodically evaluate their significance, the generated chain of cause-consequence, the root causes of failure, and the top event of damage.

The significant variables in the study were:

- temperature;
- sand flow;

The temperature can change in the intake circuit and the flow of sand can vary on the production line of the dried sands.



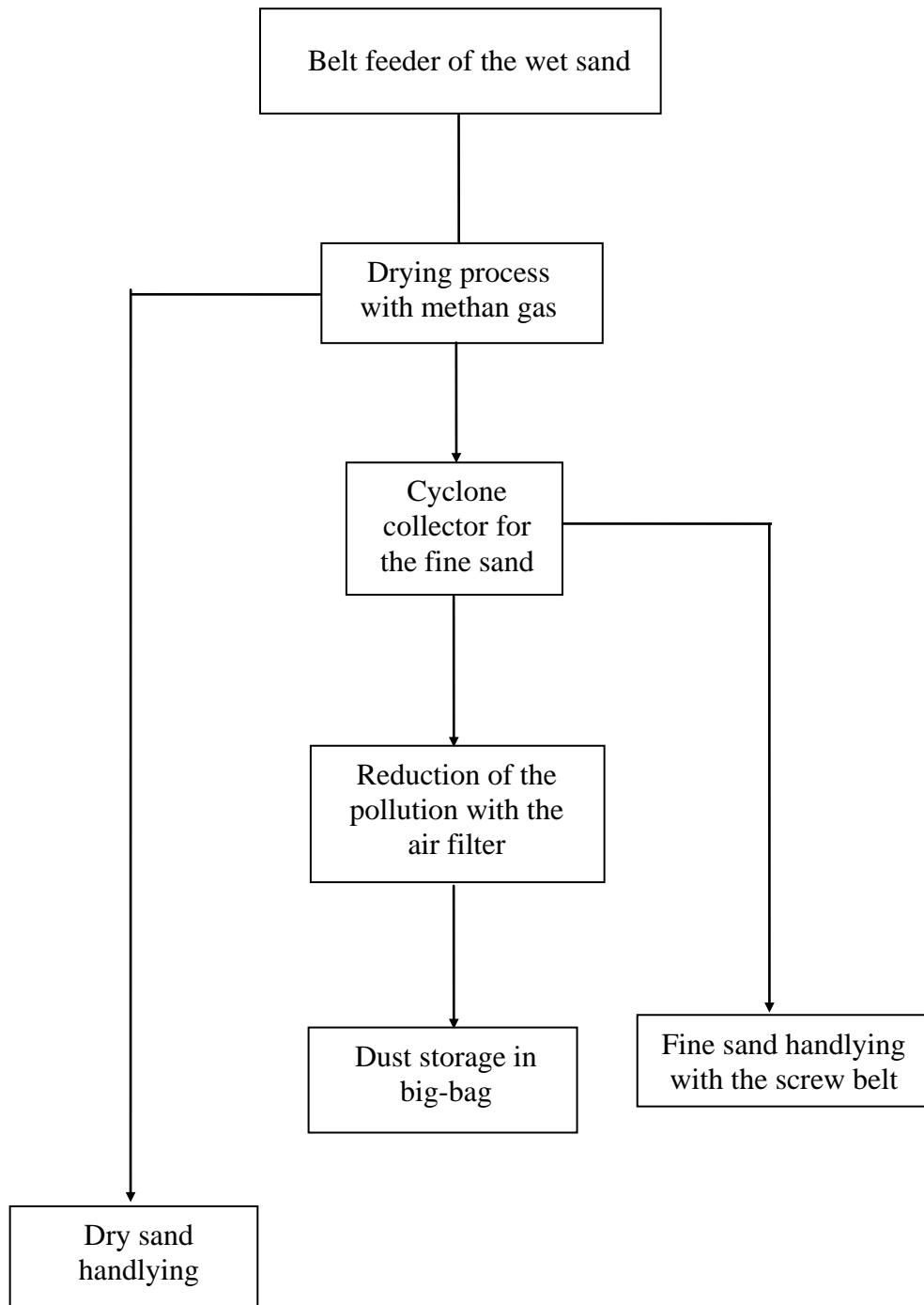

Figure 7.3: Functional block diagram of the system.

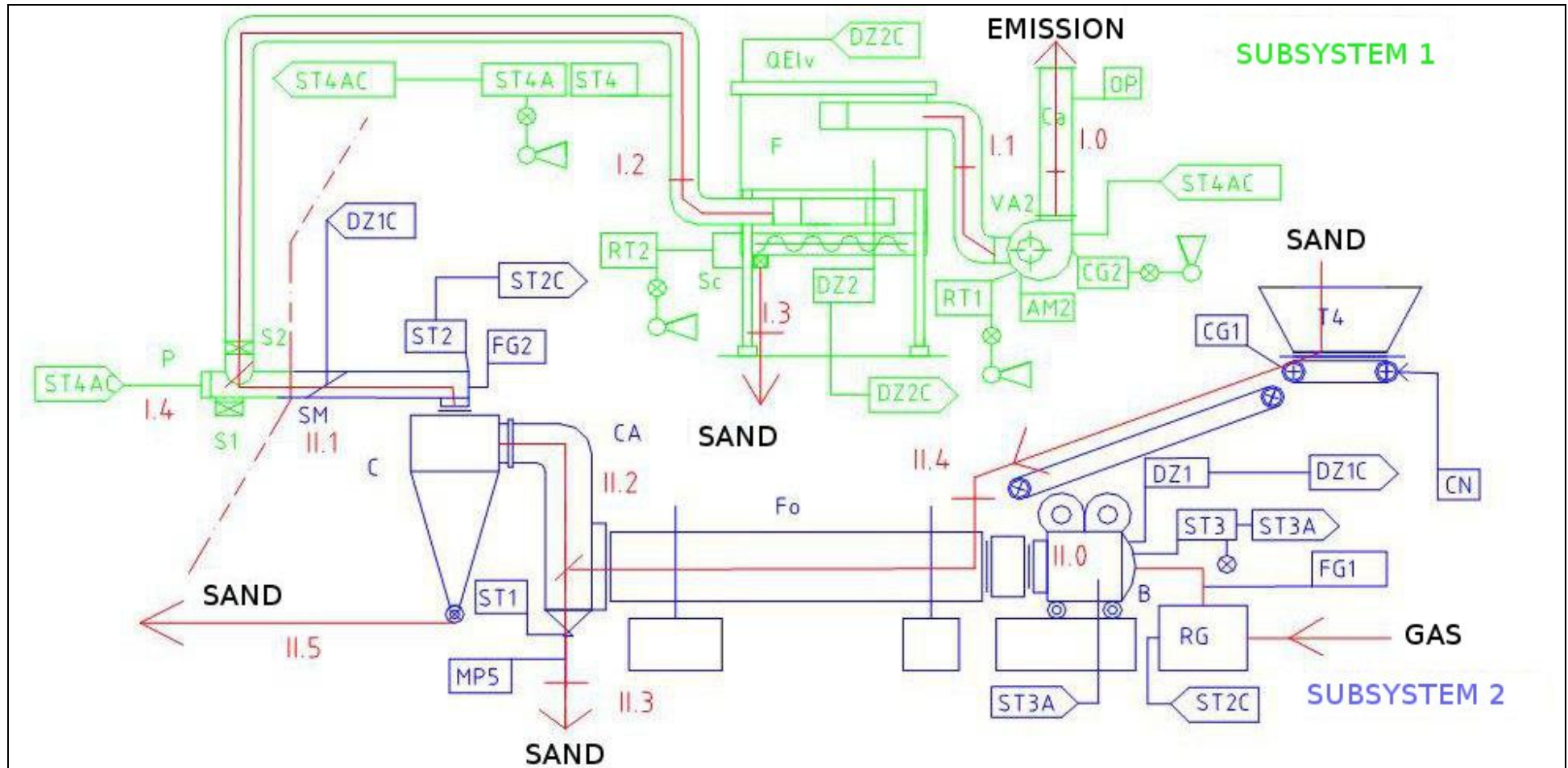

Figure 7.4: Flow diagram of the system with partition into two identified sub-systems and with an indication of the nodes analysed

T4	Belt feeder
B	Combustion chamber
RG	Gas ramp
Fo	Rotating dryer
CA	Abatement chamber
C	Cyclone
SM	Butterfly valve
S1	Shutter
S2	Shutter
P	Gate
F	Air filter
Sc	Unloader (star valve)
VA2	Fan
CG1	Round controller of the belt feeder
CN	Flow regulator of the incoming materials
FG1	Flow gauge of the gas
DZ1	Pressure gauge in the combustion chamber
ST3	Thermometer of the boiler
ST3A	Temperature alarm
ST1	Thermometer of the sand coming out from the rotating oven
MP5	Weight gauge of the sand coming out from the rotating oven
FG2	Flow gauge of the emission coming out from the cyclone
ST2	Thermometer and Thermocontroller of the flow
ST4	Thermometer of the flow incoming in the filter
ST4A	Temperature alarm of the filter
DZ2	Block gauge of the filter
AM2	Ammeter of the fan
CG2	Round controller of the dryer
CG2A	Alarm of the round controller of the dryer
OP	Opacimeter
RT1	Relais of the fan
RT2	Relais of the unloader

*Table 7.5: List of symbols*

---

DZ1 manages SM in a entire open position with an under pressure value of 2mbar measured in B;

---

VA2 works at 3000 rounds/min. with a head of 35mbar constant sucked flow rate - the head loss along the suction line cause a lowering of the depression in correspondence of the head of the oven;

---

S2 blocked open;

---

S1 blocked closed;

---

P closed;

---

RG feeds gas in 0.8-0.9 position - RG is considered as a single block and it represents the feeding with methane gas possessing arrest devices, functioning, intercepting, stabilization, filtering, regulation, Safety typical of this type of line

---

*Table 7.6: Starting operative conditions*

DEVIATIONS	POSSIBLE CAUSES	CONSEQUENCES	WARNINGS	INTERVENTIONS	NOTES	TE
Fo – High temperature	RG – does not function	II.2 - High temperature			<b>1</b>	
	II .4 - low/no feeding flow					
II .4 – low/no feeding flow	Feeding regulation system malfunctioning	Fo - increasing temperature				
	Fo gives no permission					
II.2 - High temperature	Fo - High temperature	II.3 High temperature II.1 - High temperature				
II.1 - High temperature	II.2 - High temperature	I.2 - High temperature	ST2	RG		
II.3 High temperature	II.2 - High temperature	Lower production efficiency				<b>7</b>
I.2 - High temperature	II.1 - High temperature	Damage to F	ST4			<b>6</b>
Feeding regulation system malfunctioning	CN out of order *	II .4 - low/ no feeding flow	CG1			

Table 7.7: Analysis of operability of the subsystem 2

DEVIATIONS	POSSIBLE CAUSES	CONSEQUENCES	WARNINGS	INTERVENTIONS	NOTES	TE
Fo - Decreasing temperature	RG - does not function *	II.2 - Low temperature			1	
	II .4 - high feeding flow	II.0 High temperature				
II .4 - high feeding flow	Feeding regulation system malfunctioning	Fo - Decreasing temperature				
II.2 - Low temperature	Fo - High temperature	II.3 Low temperature II.1 - Low temperature				
II.1 - Low temperature	II.2 - Low temperature	I.2 - Low temperature	ST2	RG		
II.3 Low temperature	II.2 - Low temperature	Wet sand				3
II.0 - High temperature	II.2 - Low temperature	Damage to the combustion chamber		ST3A		4
	VA2 in arrest					
I.2 - Low temperature	II.1 - Low temperature	Higher consumption at VA2 Condensation in tubes				5

The Hazard Identification technique suitable for the prevention and deviation management

	P malfunctioning, open					
Feeding regulation system malfunctioning	CN out of order *	II .4 - high feeding flow		CG1		
II.5 - No feeding sand	Obstructed Rotating cell RT Rotating Cell does not intervene	F – highly polluted flow				

Table 7.8: Analysis of operability of the subsystem 1

- 1 RG malfunctioning indicates a complex correlation of deviations internal to the gas line which would need an in depth analysis to conduct elsewhere, since the objective of this work, polluting emissions, do not consider fire as a problem.



DEVIATIONS	POSSIBLE CAUSES	CONSEQUENCES	WARNINGS	INTERVENTIONS	NOTES	TE
I.3 - Eccessive fine sand	F - Highly polluted flow	I.0 More polluting overloaded		RT2		<b>2</b>
I.0 More polluting overloaded	I.3 - Eccessive fine sand	Polluting emissions at the chimney	OP			
F – highly polluted flow	II.5 - No sand	I.3 - Eccessive fine sand	DZ2			
I.0 More polluting overloaded	Broken hose	I.0 More polluting overloaded	DZ2			<b>2</b>
	Elv blowing					
I.0 More polluting overloaded	I.3 - Eccessive fine sand	Polluting emissions at the chimney	OP			
VA2 in arrest	motore – giunto malfunctioning	Emissions in the working environment		CG2		<b>1</b>
	RT1 salta*	II.0 High temperature				
MF engine - joint	Broken Joint	VA2 in arrest				
	Broken Belt					
	Binded Bearing					

Table 7.9: Analysis of operability of the subsystem 1

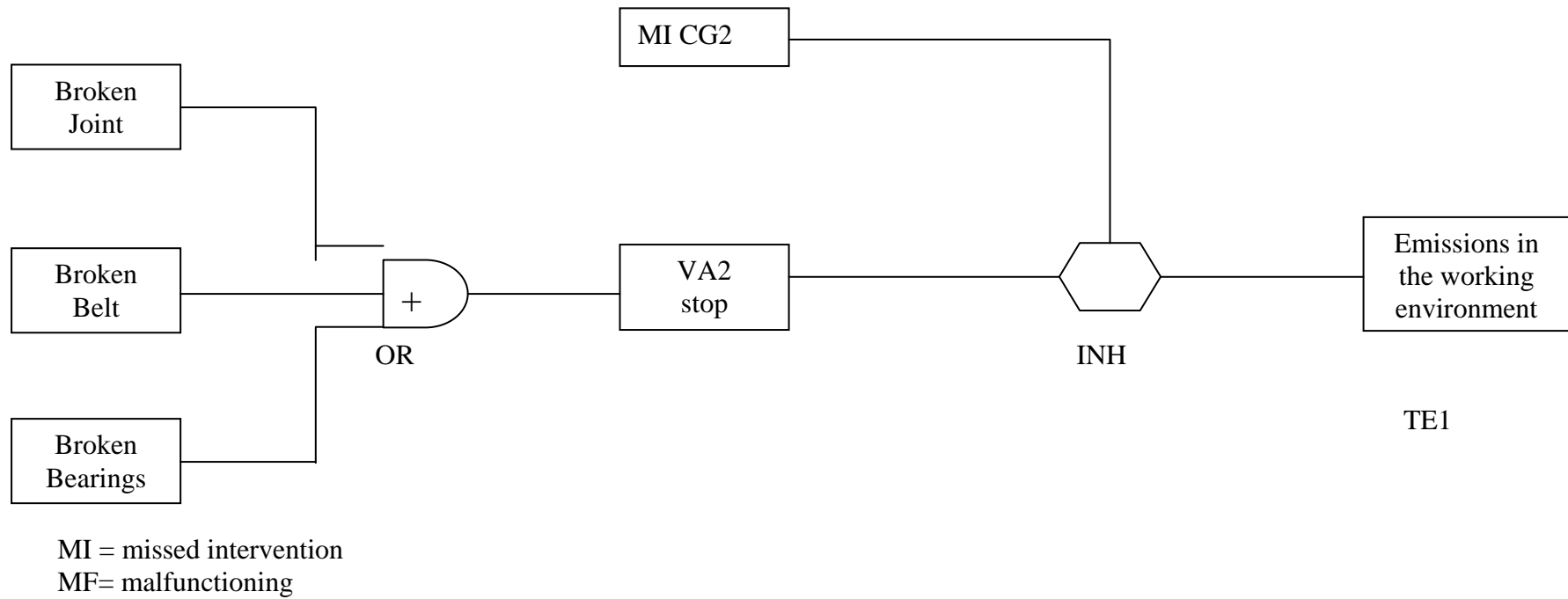
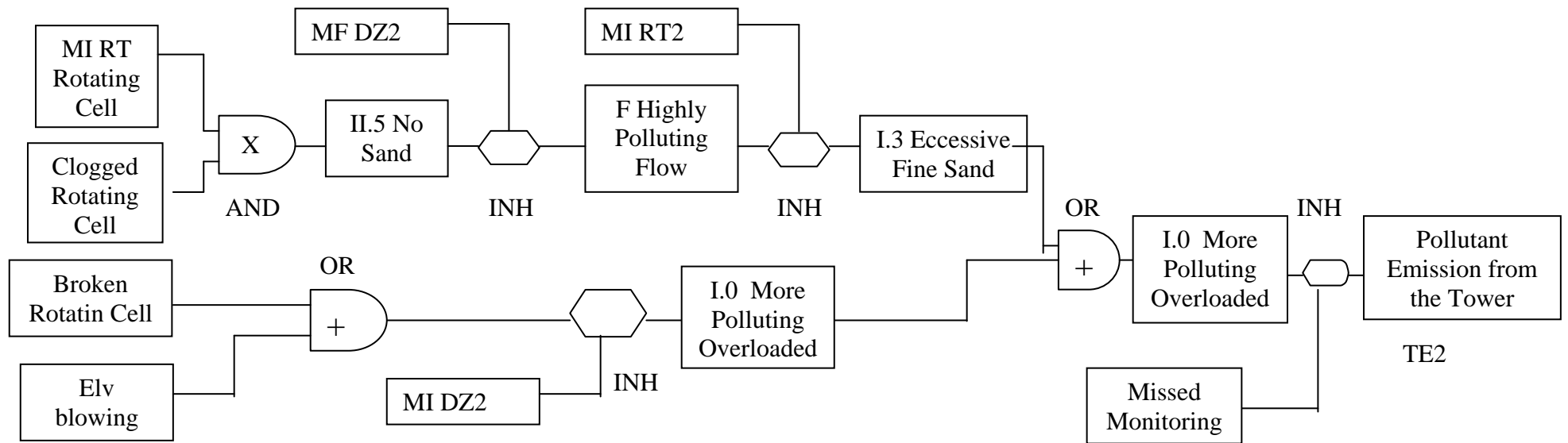

Figure 7.10.: Diagram of the accident sequence TE 1



MI = missed intervention

MF= malfunctioning

Figure 7.11: Diagram of the accident sequence TE 2

### 7.2.1.1 Results

The evaluation of the possible deviations from the project which lead to the unscheduled events such as “emission in the workplace” or “emission out of the workplace through the chimney”, follows the keywords of the technique and proceeds to reach the top events.

The systematic study of the process highlights those deviations that lead to unexpected consequences that therefore need further investigation; it should be noted that the study put in evidence only deviations from a reality that can actually happen.

The polluting emissions can come out from the chimney also during the correct safe operations of the system, such as a considerable flow of dry sand at the belt feeder which spreads fine particles with micron size or such as the cleaning of the air filter that could generate a temporary increase in the pollutant at the chimney.

The most common cause of pollutant emission at the chimney seems to be the breakage of the filter, although the “quite” remote possibility of overfeeding of the cyclone is as real as probable.

The problems of the issue in the workplace are really negligible. First of all, because the system works in under-pressure and it intakes air rather than to flow out the pollutant; moreover because an unreported arrest of the flow does not spread a large amount of pollution (emission is temporary) in the workplace, in relation with the lack of pressure due to the protection devices (ST3A).

Other hazards identified in the study were related to the machinery (cyclone, filter or fan), characterised by its Safety and control devices.

### **7.2.2 Checklist analysis applied to a feeding, crushing and milling plant**

In a traditional Checklist Analysis the key is to create a list of specific items to identify known types of hazards, design deficiencies, and potential accident situations associated with common process equipment and operations. The Checklist analysis technique can be used to evaluate materials, equipment, or procedures in order to focus on aspects of a problem that are yet unknown, to then proceed, if it is necessary, with other investigations. It is applicable to any type of plant.

More often this kind of technique is adopted to ensure or verify that a piece of an equipment conforms with accepted standards and it may also identify areas that require further evaluation.

The level of detail of these lists can be very variable according to the purpose of the study.

The method is divided into two phases:

- ★ in the first part the checklist has to be created in accordance with the current legislation and the experience of other equipment or similar situations;
- ★ the second phase is characterised by the application of the created checklist, by finding the aspects which are not present regarding the equipment or machinery and on which a further detailed study will be conducted.

This phase is less complex: the structure of the checklist and the quite common answers use, such as "yes / no", "not applicable" or "it needs more study", make the analysis relatively simple. It is a list of points in order to check the status of a system or plant.

After that, the created Checklist has to be proposed to the workers of the plant, to the maintenance personal and to the Safety manager.

The checklists have the advantage that they can be adopted in several situations. On the contrary, they often are too simplified or too elaborate depending on the system that has to be verified. The results are the identification of potential hazards, the keeping of the Safety standards of the plant and, in general, the agreement of the regulations and procedures.

### 7.2.2.1 The feeding, crushing and milling plant

The feeding, crushing and milling plant analysed is part of a more complex facility of material production sited in Western Italy which includes also extractive activities and bituminous aggregate.



*Figure 7.12: View of the analysed plant.*

### 7.2.2.2 Operation and cycle of the plant

The material fed into the primary crushing machinery is transferred by a conveyor belt to the screen; from the first screen the mineral is moved to the secondary crushing for the further size reduction; by a system of conveyor belts it is sent to other screens to be selected again and then to the final storage; the screening operations are carried out with water for the entire cycle; the mud produced during the screening phases is recovered by cups and cyclones to be compressed and reutilised.

The working of the plant is entirely automated and is controlled by the operator from a soundproof box from which it is possible to perform the following functions:

- ★ To start and stop the engines of the different machineries;
- ★ To manage the starting sequence of the machinery;
- ★ To make adjustments ;
- ★ To manage the emergency situations.

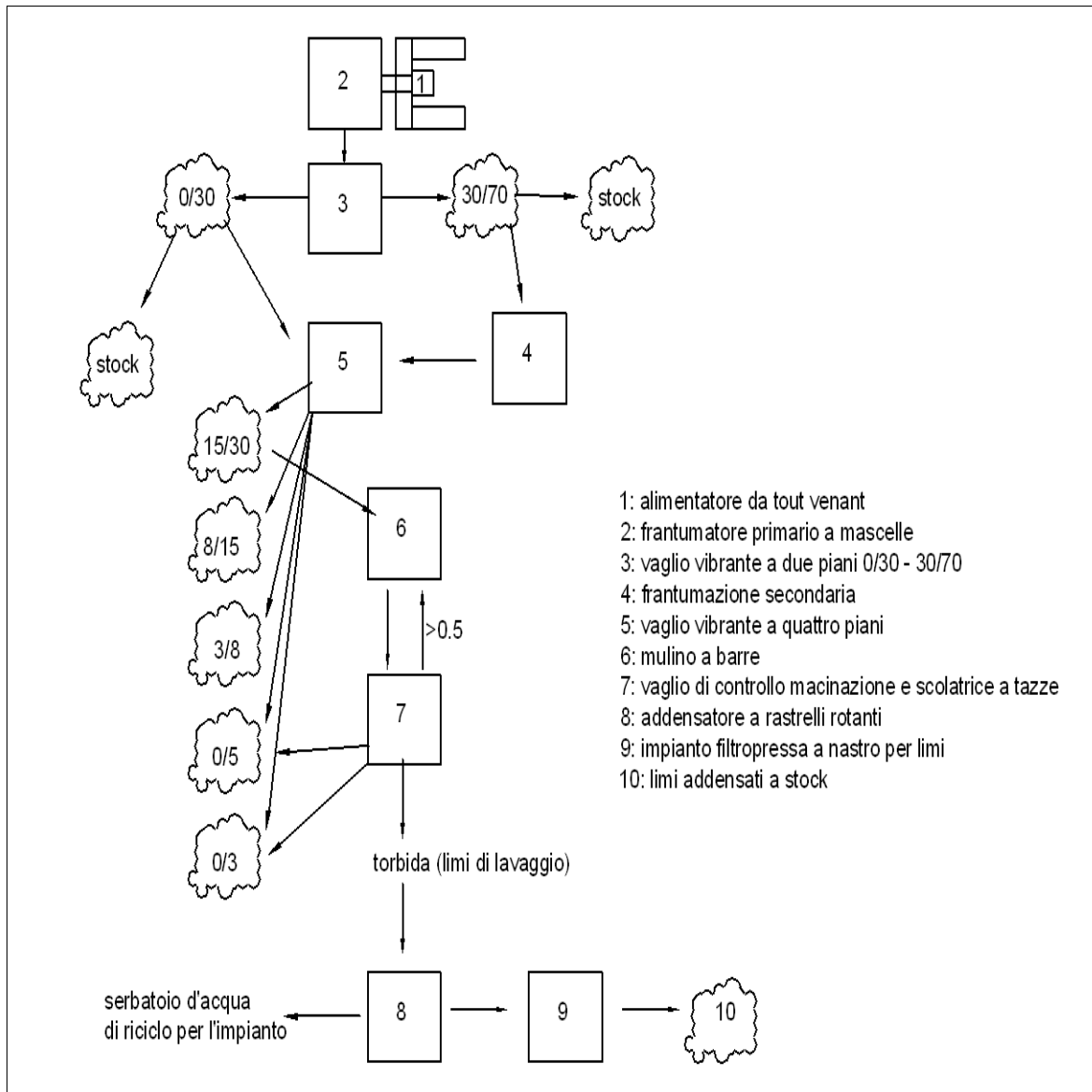

Figure 7.13: Block diagram of the plant

Primary vibrant feeding machinery tipo AVP 800 - Loro & Parisini

Jaw crusher CR 75.5 - Loro & Parisini

Weighing machine Ramsey. MIDI 44 - 101 - Ramsey Italia

Vibrant screener mod. 554 a 2 piani - Loro & Parisini

Vibrant feeling machinery - Loro & Parisini AVN 575/1250-N. 2

Hammer mill MR 129 - Loro & Parisini

Four level vibrant screener 557 - Loro & Parisini

Impact mill trz 96 - Loro & Parisini

Rod mill - Loro & Parisini

Cup-dewatering machinery - Loro & Parisini. mod. RST 10/40 N. 2

Drying screener VSN 203 - N. 2 - Loro & Parisini

Table 7.14: Main equipment and machineries that composed the system

As mentioned above, the Checklist is a list of questions with the aim to evaluate the current state of a system.

During the drafting of the list, the regulations and the technical standards available for the feeding, crushing and milling plants were taken into account.

Two different Checklists were prepared: the first one was based on the general principles contained in the Annex 1 of the Legislative Decree. 17/2010 (applied to all machineries and equipment of the system) and the second one based on the suggestions included in the technical draft standard prEN1009-3 of the European Community, for the jaw crushers. In the annexes both Checklist are reported; below only the structure of the checklist used for the crusher is shown.

### 7.2.2.3 Results

The adopted checklist allowed to identify some critical points of the crusher. The criticalities are mainly related to the lack of protection facilities on several moving parts of the crusher and related to the rather poor assessment and management of some risks associated with particular hazards highlighted by the European technical draft.

The critical points were subsequently communicated to the personnel in order to evaluate technical solutions suitable to improve the Safety and to reduce the critical issues highlighted by the applied methodology and to install the missing guards.



*Figure 7.15: Side view of the primary jaw crusher*



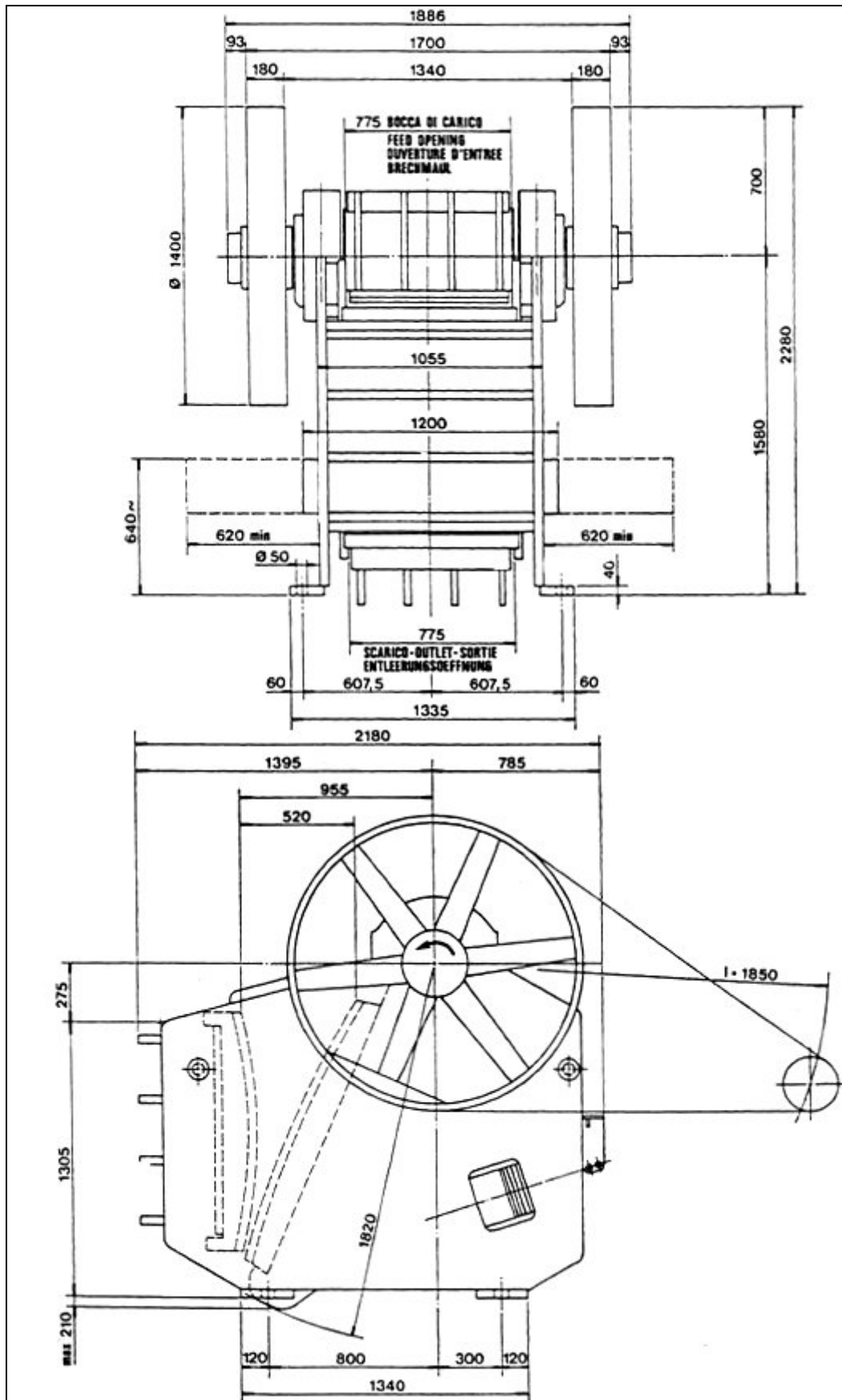

Figure 7.16: Technical scheme of the primary jaw crusher

<b>Workplace:</b>	<b>Date:</b>	<b>Next review:</b>
<b>Filled by:</b>		

**JAW CRUSHER**

<b>prEN1009 - 3</b>	<b>INSPECTION</b>	<b>ANSWER</b>		<b>NOTE</b>
5.1.1 – Removal of the offending stones from the cavity of the crusher	To clear an obstruction in the crushing cavity, was an overhead crane with a suitable grab or pick, or an hydraulic arm, also equipped with a grab or pick or an hydraulic arm fitted with a pneumatic or hydraulic hammer set up?	YES	NO	
5.1.2 – Platform to control the fed materials	Is the platform provided of suitable guard rails to prevent personnel falling into the crusher feed opening during the overview operation?	YES	NO	<i>If the access platform is attached to the equipment supplied by the manufacturer, then it will be the manufacturer's responsibility to supply the platform. If it is attached independently of the supplier's equipment, then the user has responsibility for the access platform and the manufacturer shall bring the attention of the user to this matter in the Instruction Handbook (I.H.).</i>
5.1.4 – Breaking of the tension spring system of the crusher's jaw	Was the crusher provided for hands and feet protection to be prevented from touching the tension springs which project from the rear of the crusher.	YES	NO	<i>It should be carefully evaluated the tension energy stored up in the crusher's jaw to prevent a possible projection.</i>
5.1.5 – Stone material projection	According to the construction features of the machineries the Residual Risk related to the material projection during the working is not negligible. Are the rubber protections set up in the crusher cavity in order to reduce the stone material projection?	YES	NO	

## References

Center for Chemical Process Safety of the American Institute of Chemical Engineers, 1992, Guidelines for Hazard Evaluation Procedures Second Edition with Examples, American Institute of Chemical Engineers, New York, United States of America.

E.L. Chao, J.L. Henshaw, Occupational Safety and Health Administration. Job Hazard Analysis, <http://www.osha.gov/Publications/osh3071.html>, 2002.

W.C. Christensen, F.A. Manuele, Safety through Design, 1999.

European Commission, Guidance on risk assessment at work, Directorate – General V Employment, industrial relation and social affairs, 1996.



*Contents*

*Start of the  
Chapter*



# CHAPTER 8: THE MANAGEMENT OF THE POSSIBLE DEVIATIONS

## *A CASE STUDY IN AN UNDERGROUND SILICA QUARRY*

*"Le idee fisse sono come dei crampi, per esempio ad un piede: il rimedio migliore è camminarci su"*

*Søren Kierkegaard*

**THE PROBLEM:** why and how is it really necessary to manage the possible unexpected deviation?

### 8.1 INTRODUCTION

Monitoring the conditions of the underground environment involves the sampling and the analysis of the air to insure the continued health, Safety and productivity of the personnel. The control of the underground environment, meanwhile, involves the adjustment, modification, alteration, or correction of an existing or incipient undesirable situation in order to attain or maintain a suitable underground condition. Although incremental, cyclical, or random monitoring of the mine environment is satisfactory in some cases, continuous monitoring, especially, on a mine-wide basis, would have overwhelming benefits for the overall health, Safety and productivity of underground miners. If continuous monitoring were coupled with remote ventilation control, dramatic improvements in the underground environment and most certainly in the efficiency of miners and equipment could be achieved. Unfortunately, at this time, continuous monitoring and remote control of the environment are still essentially in the “world of the idea” in the area where the case study was carried out.

It should be noted that a continuous monitoring it is quite essential to provide very fast and well-tested answers in emergency conditions guaranteeing the survival of the workers.

Even if since twenty years the number of the Italian quarrying operations in underground is steadily growing, for technical reasons and to reduce the perceived environmental impact in intensively dwelled areas, in many cases the Safety criticalities are somehow underestimated, and the ventilation system design is mainly conceived to face quite simplified requirements, whilst critical pollutants or emergencies and availability are not taken in due considerations.

The research work started since some years ago, and still in progress, on an underground drift sub level exploitation of silica in Northern Italy to identify environmental Safety criteria suitable to achieve effective Safety and health conditions for the workers in natural situation and to ensure an improvement in the ventilation system and prevention / protection management of emergencies in the underground levels of the quarry due to the development of the exploitation operations.

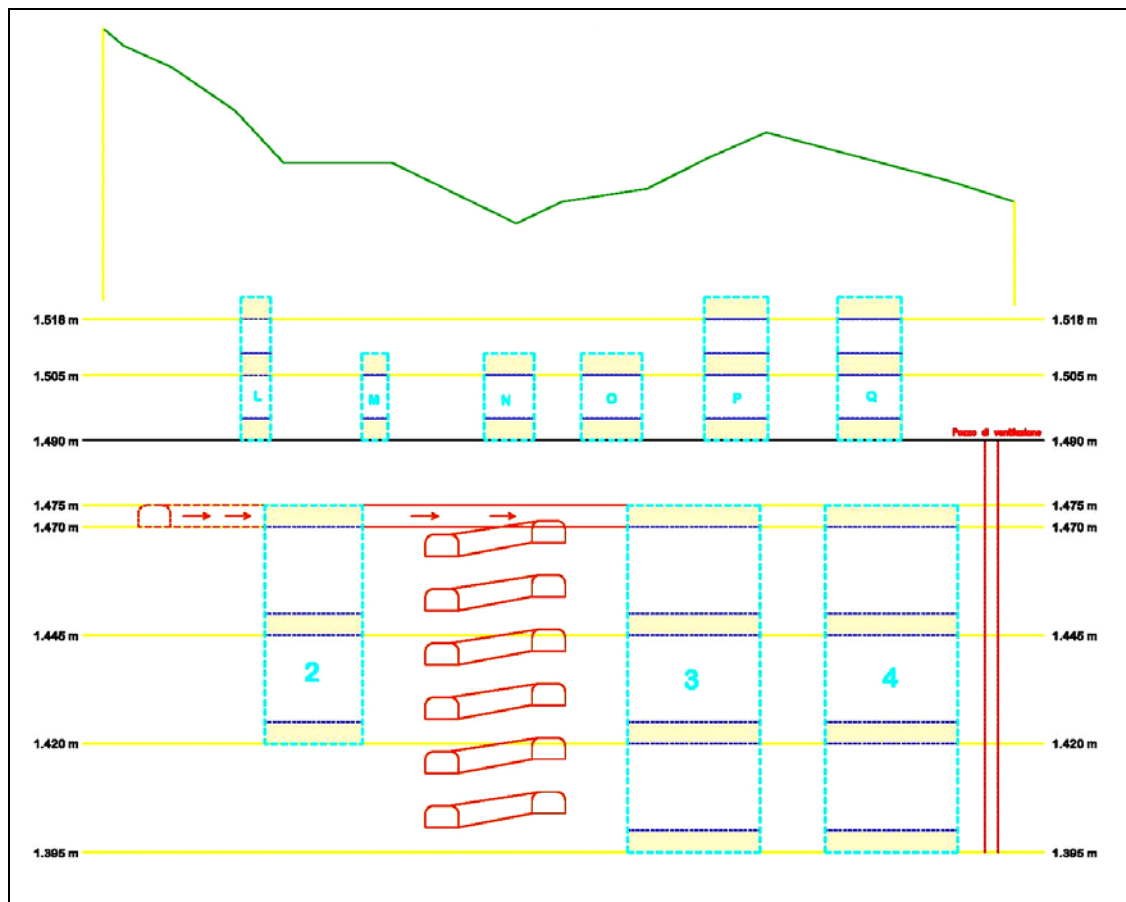

Figure 8.1: Section of the drift sub level exploitation with the old (L, M, M, O, P, Q) and the new (2, 3, 4) excavation rooms.



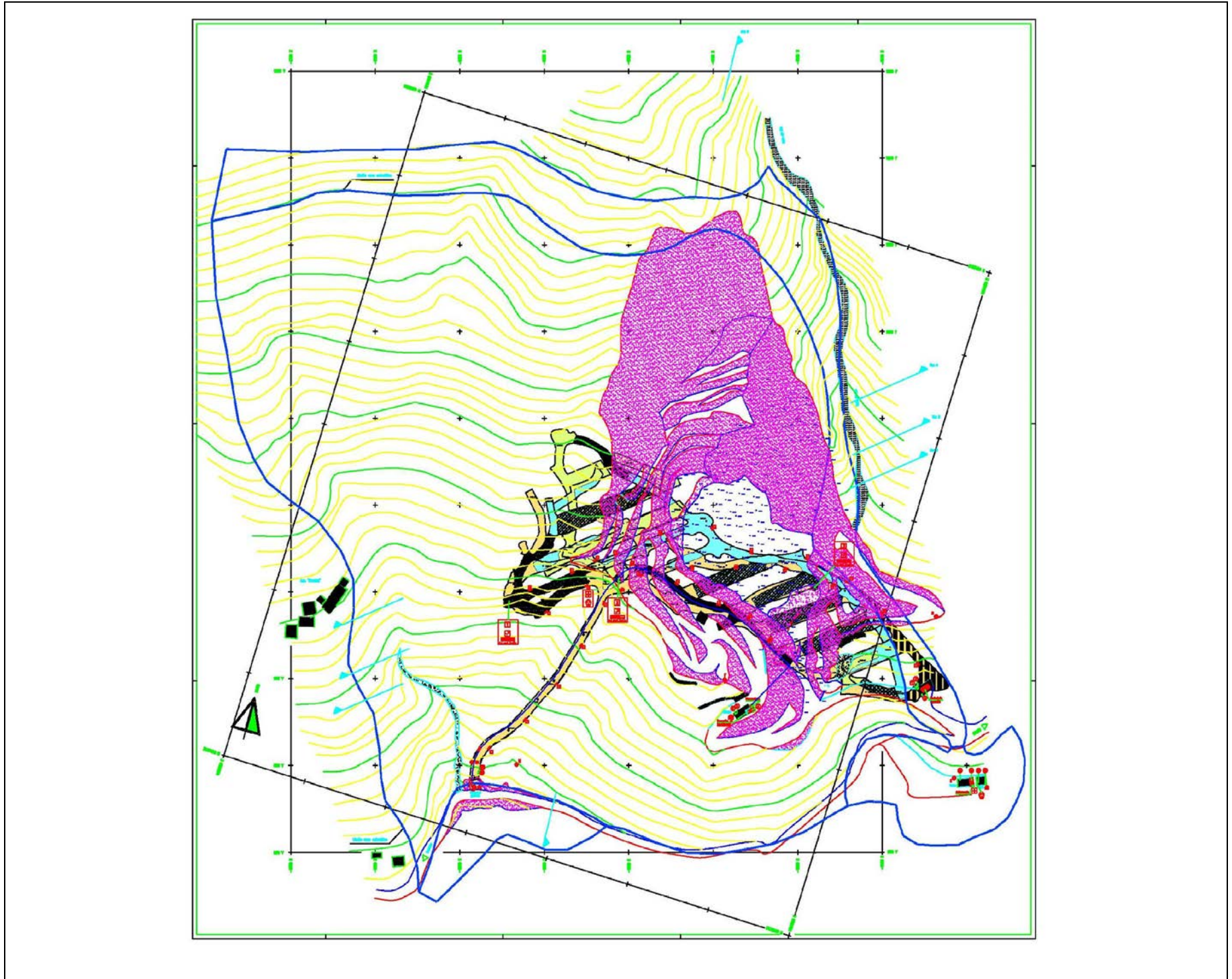

Figure 8.2: Plan of the drift sub level exploitation with the old opencast benches (pink) and underground levels (yellow, blue, black).

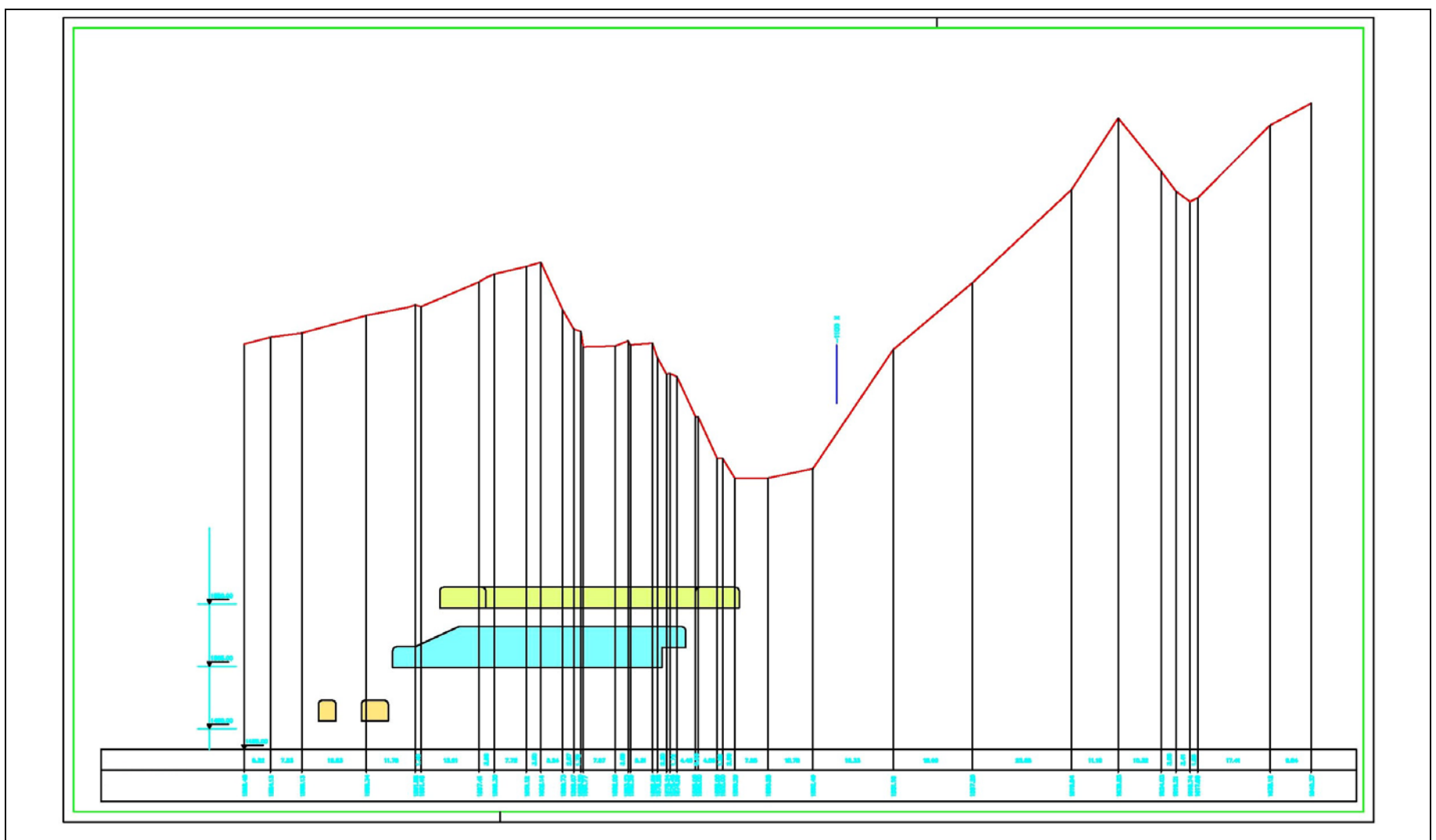

Figure 8.3: Section of the drift sub level exploitation with the old opencast benches (red line) and underground levels (yellow, blue).

Taken into account that the logical -and mandatory- phases for an effective approach to the Safety and health problems in underground operations must follow a hierarchical management where the ventilation layout and fittings cannot be considered the main or even unique solution, but it should be shown the preliminary definition of a series of input parameters as in particular the emission of pollutants due to the rock winning and mucking operations.

Moreover, the achieved residual risk has to be then faced -for the existing situation and for the planned future lower levels- with both an underground airways layout definition, and ventilation components dimensioning in presence of natural draft, based on technical and efficiency considerations for the management of the normal operation situations, and on availability analysis for the emergencies management (mainly in case of fires).

To guarantee an acceptable quality of the work environment, the emission of pollutants from diesel machines and explosives have to be investigated, in order to minimise where possible by substitution and to strictly control and to carefully manage the particulate pollution. To reduce the fire risks, also the flammable materials it always advisable to limit to a minimum and the machinery equipped with fire extinguishing devices.

The targets being effective results, fast ventilation system responses and flexibility to several input conditions, on this basis some valuable information were got on the ventilation system's availability needed improvements, to reduce to the minimum reachable level both the unscheduled production interruptions and the accident scenarios, emergency alarms, extinguishing and fire fighting systems, and plant response to natural draft due to season changes or to fire situations included.

In the studied case, moreover, a preliminary availability analysis of the ventilation system was carried out, for the normal operating conditions and the emergencies management on the basis of the results of two different Hazard Evaluation techniques (HAZOP and Fault Tree Analysis)

Finally, the last step have to be the locating of the safe areas and the defining of the emergency procedures in detail to face the “*Residual Risk*”.

## 8.2 THE METHOD

The control of the underground environment involves the adjustment, modification, alteration, or correction of an existing or incipient undesirable situation in order to attain or maintain safe working conditions.

In order to carefully identify all the possible situations, the general underground layout (Figure 1) was analysed with the use of simulation software fed with directly collected input data, and some modifications introduced, on the basis of the assumption that an upward flow has to be granted in any situation, and both the flow reversal risk and the presence of workers in the fumes polluted areas should be avoided at the very first stage of the ventilation layout and fittings design (with special reference to the possible presence of workers in areas polluted by fire fumes, the residual risk not directly eliminated by the underground layout design must be managed in terms of organisation, and, if necessary, with the introduction of rescue chambers).

The first step was the direct measurement of pressure (direct or in terms of pressure difference along the airways) and flow-rate (from velocity and airway cross section) in 17 representative stations along the main airways<sup>12</sup>: a series of measurement campaigns carried out in different seasonal conditions (on 19<sup>th</sup> November 2010 and 11<sup>th</sup> May 2011) made available the different values of the aforesaid parameters due to the different natural draft situations, and to the thermal contribution of the diesel and electric machineries, often sufficient to overcome the head losses<sup>13</sup>. It must be underlined that the latter statement involves the possibility of natural descending ventilation, with the possibility of flow reversal in case of fire: such a situation can be managed only<sup>14</sup> by the adoption of a mechanized ventilation system including a fan located at the higher level (1530 m) to grant a constant ascending flow from the clean air entrance (1490 m) in all seasonal, weather conditions and underground situation.

---

<sup>12</sup>The spot data resulting from the campaigns were confirmed by routine simplified measurements systematically carried out by the underground supervisors.

<sup>13</sup>The Bernoulli equation states that the thermal energy added to the system is converted into a pressure head capable of producing airflow.

<sup>14</sup>As logical -and mandatory- the Safety management of underground workplaces must be managed in a strictly hierarchic order where the ventilation systems (i.e. the removal of polluted air) should be considered *after* a series of control solutions on the generation and emission of pollutants, both in normal and emergency situations.



Inspection 19 <sup>th</sup> November 2010	Inspection 11 <sup>th</sup> May 2011
Difference in pressure	Difference in pressure
Air velocity	Air velocity
Air temperature	Air temperature

Table 8.4: The main inspections carried out

### 8.3 THE SIMULATION

The simulation analysis was carried out by means of a 1D (nodal points) software to evaluate the airflow amount and distribution on the basis of the data acquired through the measurement campaigns, and to identify the best layout and ventilation hardware (fan, monitoring and regulation devices, etc.) to adopt. Moreover, some calculations have been developed in detail by means of CFD (Computational Fluid Dynamics) “FDS®” software (National Institute of Standards and Technology of the United States Department of Commerce, 2010) in different areas of the underground, involving different fire emergency scenarios, to locally confirm in detail the achieved results.

In every case a fire of 10 MW power was considered, representing the combustion of a truck reaching a steady state in 500 seconds.

Finally, to optimize and simplify the layout of the airways and properly simulate the possible interventions necessary for the management of the natural draft, some boundary conditions was assumed<sup>15</sup>:

- ★ the chimney, considered as the favorite air communication between the level 1518 m. and the old underground exploitations at the higher levels, has been closed;
- ★ the closure (so avoiding obvious short circuits in the general ventilation net) of all exhausted rooms located at 1490 m, with the scheme proposed in the following pages, holding up the branches called "R24", "R48" and "R47". A similar solution was adopted for the exploitation level at 1505 m. where it is necessary having regard to the closing of branch "R7".

These simplifications should help to significantly reduce the uncontrolled flow of air through the rooms, making it possible to manage a well-defined situations in normal and emergency situations.

<sup>15</sup> It should be noted how these conditions and suggestion were adopted after the validation of the method.  
The Prevention Through Design Approach in the mining activities

For these reasons was carried out several simulations characterised by different configurations and characterised by the presence of a sudden strong source of heat, such as fire, in the nodal point "N20" (the ramp to access at level 1505 m.) and in the nodal point "N17" (in the middle of the level at 1505 m.).

All the simulation carried out with the 1D nodal points simulation software are summarised in the table below:

<b>EXECUTED SIMULATION WITH THE NODAL ANALYSIS TO VERIFY THE VENTILATION CONDITION UNDER SET UP CONDITIONS</b>	
<b>UNDERGROUND LAYOUT</b>	<b>FIRE</b>
<ul style="list-style-type: none"> <li>❑ Opened Chimney N6, Opened Exhausted Rooms at levels 1490/1505 m.</li> <li>❑ Closed Chimney N6, Opened Exhausted Rooms at levels 1490/1505 m.</li> <li>❑ Closed Chimney N6, Closed Exhausted Rooms at levels 1490/1505 m.</li> <li>❑ Closed Chimney N6, Closed Exhausted Rooms at levels 1490/1505 m.</li> <li>❑ Closed Chimney N6, Closed Exhausted Rooms at levels 1490/1505 m.</li> </ul>	<ul style="list-style-type: none"> <li>❑ Fire at ramp to level 1505 m., nodal point "N20"</li> <li>❑ Fire at level 1505 m., nodal point "N17"</li> </ul>

*Table 8.5: 1D nodal points simulations carried out*

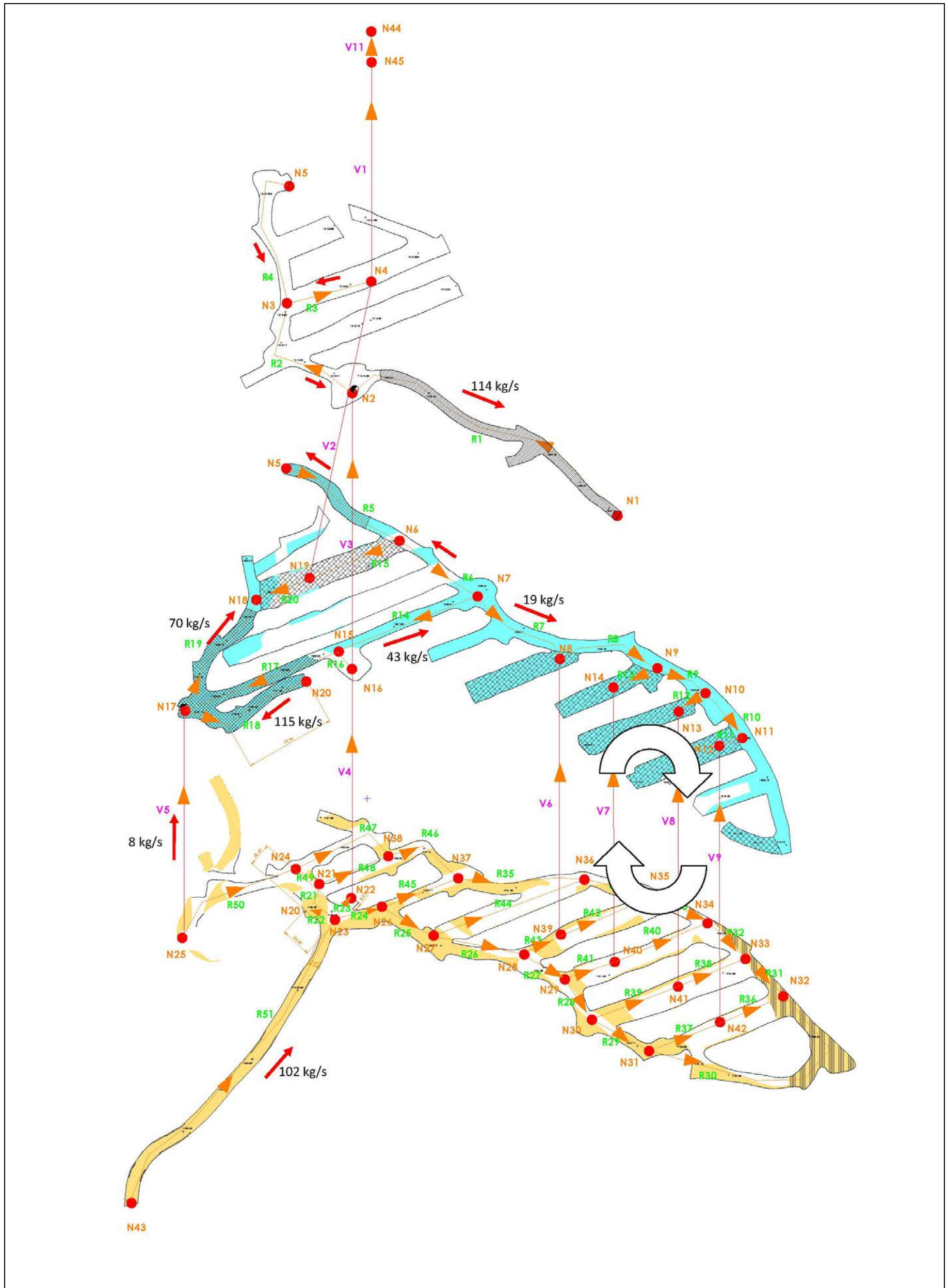

Figure 8.5: Underground levels scheme of the silica quarry adopted in the simulations carried out with 1D nodal points simulation software "White Smoke" to evaluate the direction and the volume of the airflow after a fire accidents in the node "N20" at level 1490 m.

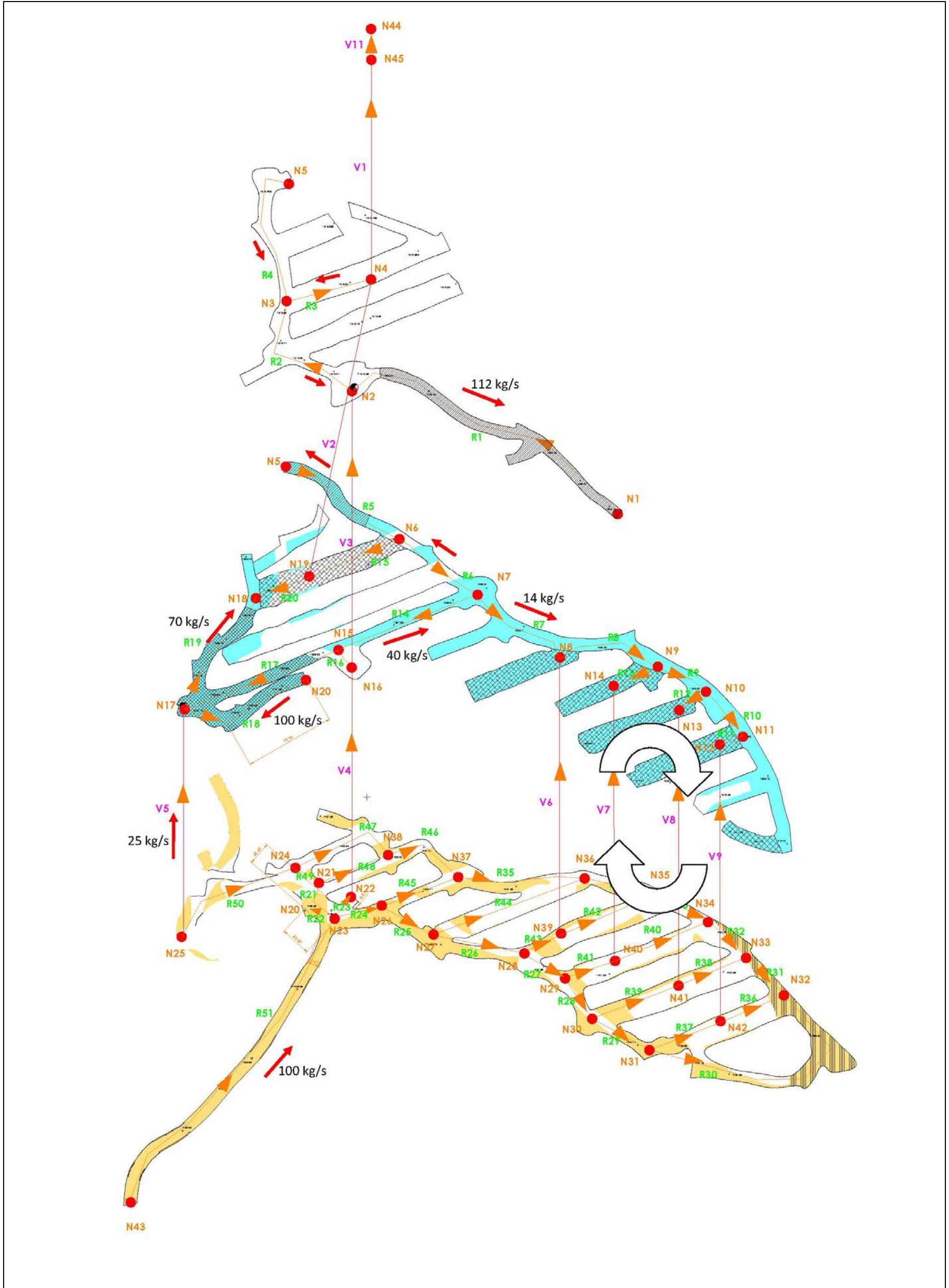
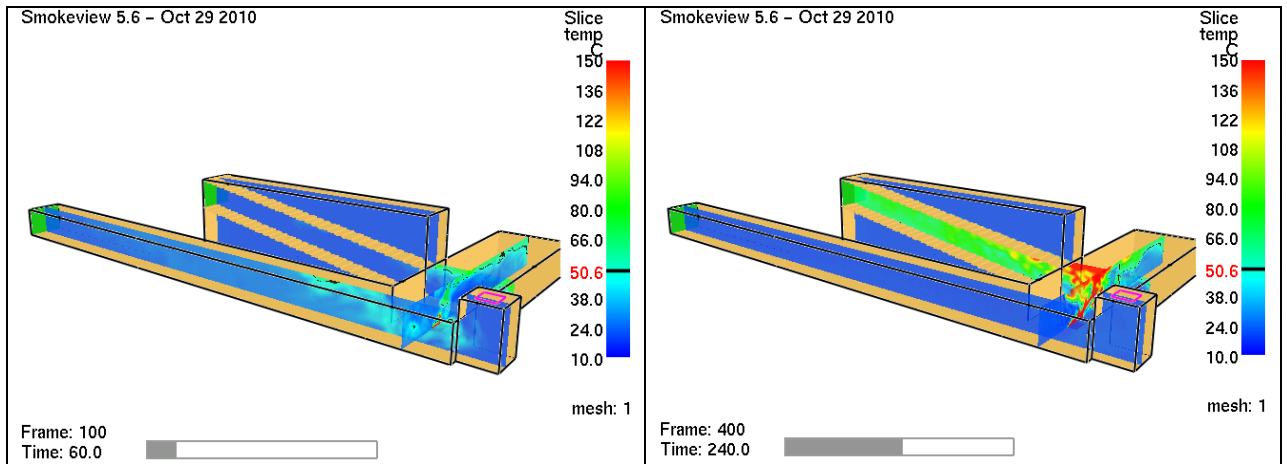

Figure 8.6: Underground levels scheme of the silica quarry adopted in the simulations carried out with 1D nodal points simulation software "White Smoke" to evaluate the direction and the volume of the airflow after a fire accidents in the node "N17" at level 1505 m.



The results of the computer analyses can be summarised as follows:

- a) the most critical situation corresponds to a fire located in the nodes “N17” and “N20” at 1490 m and 1505 m level, which represents the points of distribution of the fresh air to the whole underground, so that further detailed analysis appeared advisable;
- b) the 1D analysis put in evidence the risk of convective movements of polluted air: in particular in an hypothetical scenario of fire in “N17” and “N20”, it was possible to verify such a situation between the already exploited rooms “N”, “P”, “Q” and “R”. This phenomenon can only worsen the conditions during an emergency, substantially contributing to the rapid pollution of the whole interested levels (Figures 8.5 and 8.6). It should be moreover emphasized that also a saturation of the available air volumes can occur, leading to incomplete combustion and production of under-oxidised gases. Some modifications in the ventilation layout were then hypothesized, in particular with the exclusion from the ventilation net of all the already exploited rooms located at the 1490 m level together with the "R24", "R48" and "R47" branches: the proposed modified layout grants a substantial reduction of uncontrolled -and unnecessary- air movements, and appeared to be suitable for a well-defined analysis and management of the underground ventilation in both normal and critical conditions.
- c) the CFD analysis applied in the nodes “N17” and “N20” confirmed, as shown in Figures 8.7, 8.8, 8.9 and 8.10, the criticality of this particular nodes, and provided detailed information of the possible development -step by step along the time- of a 10 MW fire in terms of air temperature and velocity assuming as the achievement of the "steady state" after about 500 seconds.



*Figures 8.7 and 8.8: Temperature values at “60” and “240” seconds during a 10 MW power fire at nodal point ”N20”.*

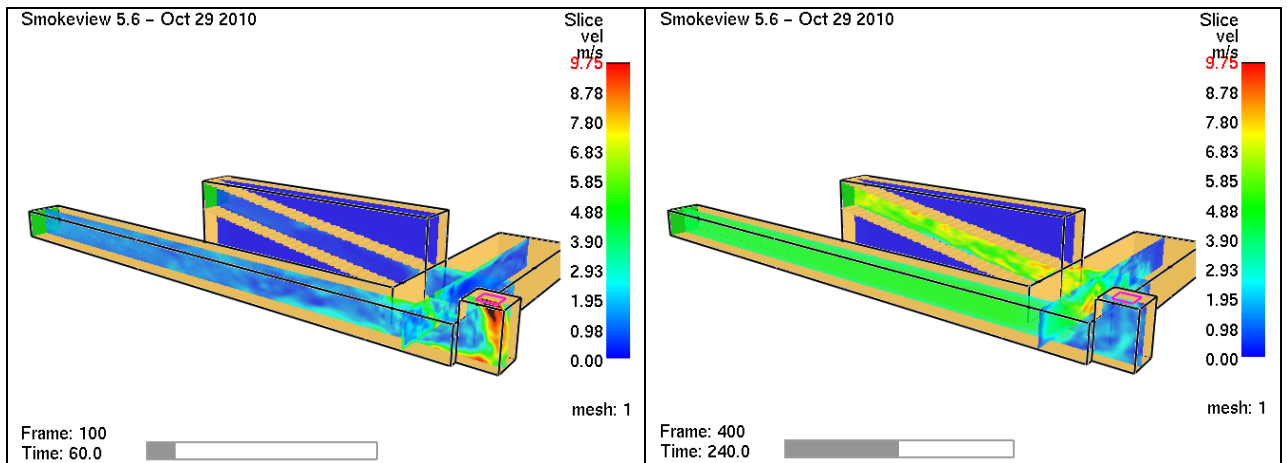

*Figures 8.9 and 8.10: air velocity values at “60” and “240” seconds during a 10 MW power fire at nodal point ”N20”.*

From the aforesaid results the ventilation layout was confirmed, and it was possible to define the most suitable characteristics of the fan to be introduced.

By these preliminary analysis was pinpointed without doubt the criticality of the scenario characterised by natural descending ventilation due to the climate seasonal conditions with the very depreciable possibility of reversal flow in case of fire. It follows that the situation will be managed only by the adoption of a fan at 1530 m. to ensure the constant ascending air flow in all weather conditions.

#### **8.4 THE DEFINITION OF THE CHARACTERISTICS OF THE MAIN FAN**

The main fan to be located at 1530 m level was dimensioned to fulfil the following requirements:

- the management of the seasonal variations of the natural draft, so that an upward air flow is in any case granted;
- the capability of an effective management of the diesel fumes emitted by the mining equipment (<sup>16</sup>): basically the trucks used for the mineral transportation at the 1490 base level (see Table 1);
- the regulations on the minimum/maximum (0,1 m/s - 6 m/s) air velocity in the underground (Italian regulation, art. 261 D.P.R. n° 128, 1959).

Such an approach was considered acceptable, provided that:

- a) no exploitation areas are ventilated in series;
- b) the fresh air intake way is different from the mined ore transportation way;
- c) a special risk assessment and management is carried out to grant safe conditions of the workers on the basis of organisation, and, if necessary, of rescue chambers for the fire emergency situations.

Moreover, the power of the requested fan have to be able not only to lead an upward motion with velocity and flow suitable to face the starting inertial weight of the air mass, but also to reverse it during the its natural seasonal direction.

Hence the need to modify the flow and prevalence provided by the fan to dilute the pollutants and the combustion residual products produced by diesel engines saving the comfort as much as possible of the workers. It be noted that it has also taken into account the limits of minimum/maximum air velocity related to the dust's risk provided by the regulations.

According to an external temperature of 20° C, to an air density value of 1.1kg/m<sup>3</sup>, the carried out simulations shown a downward airflow of 18-25 kg/s, corresponding to 16-22 m<sup>3</sup>/s (about 80,000 m<sup>3</sup>/h). Considering the type of exploitation and the co-presence in the underground of 2 ÷ 3 300 kW diesel machines, a calculation was lead to evaluate the required cubic meters able to remove the volume of gas and fumes produced by the normal combustion of diesel engines in the different seasonal cycles.

---

<sup>16</sup> the fire load is preliminarily minimised, and exclusively approved diesel machines are allowed into the underground.

<b>Combustion reaction</b>					
$C_{12}H_{24} + 18 O_2 + 68 N_2 \rightarrow 12 CO_2 + 12 H_2O + 68 N_2$					
<b>Excess air combustion reaction</b>					
$C_{12}H_{24} + 1,4 \cdot (18 O_2 + 68 N_2) \rightarrow 12 CO_2 + 12 H_2O + 7,2 O_2 + 95,2 N_2$					
<b>Simplifying supposition:</b>					
<ul style="list-style-type: none"> <li>• Diesel = n-Dodecan: <math>C_{12}H_{26} \approx</math> Dodecan-cycle <math>C_{12}H_{24}</math></li> <li>• Mixture strenght = (combustion air volume / stoichiometric combustion air volume) = 1,4</li> <li>• Temperature of the fumes = 200 °C = 473 K</li> <li>• Total combustion</li> </ul>					
<b>Data:</b>					
<ul style="list-style-type: none"> <li>• Fuel consuption <math>\approx</math> 280 g/CVh (cioè 380 g/kWh)</li> <li>• Molecular weight PM = 168 g/mol</li> <li>• Nitrogen / oxygen ratio = 79 / 21</li> </ul>					
Compuond	$C_{12}H_{24}$	$O_2$	$N_2$	$CO_2$	$H_2O$
Factor	1	25,2	95,2	12	12
Starting reaction	1,6667 mol/CV h	$1,667 \cdot 25,2 = 42$ mol/CV h	$1,667 \cdot 95,2 = 159$ mol/CV h	-	-
	2,262 mol/kW h	$2,262 \cdot 25,2 = 57$ mol/kW h	$2,262 \cdot 95,2 = 215$ mol/kW h	-	-
Ending reaction	-	$1,667 \cdot 7,2 = 12$ mol/CV h	$1,667 \cdot 95,2 = 159$ mol/CV h	$1,667 \cdot 12 = 20$ mol/CV h	$1,667 \cdot 12 = 20$ mol/CV h
	-	$2,262 \cdot 7,2 = 16$ mol/kW h	$2,262 \cdot 95,2 = 215$ mol/kW h	$2,262 \cdot 12 = 27$ mol/kW h	$2,262 \cdot 12 = 27$ mol/kW h
<b>Molar fuel consumption per hour</b>					
<ul style="list-style-type: none"> <li>• per CV = <math>280</math> [g/CV h] / <math>168</math> [g/mol] = <b>1,667 mol/CV h</b></li> <li>• per kW = <math>380</math> [g/CV h] / <math>168</math> [g/mol] = <b>2,262 mol/kW h</b></li> </ul>					
<b>Molar flow of fumes</b>					
<ul style="list-style-type: none"> <li>• 285 mol/kW h</li> <li>• 211 mol/CV h</li> </ul>					
<b>Fume production per hour with 0 °C, 0,1 MPa</b>					
<ul style="list-style-type: none"> <li>• per CV = <math>211</math> mol/CV h <math>\cdot 22,4</math> l/mol = <math>4726</math> l/CV h = <math>4,7</math> m<sup>3</sup>/CV h</li> <li>• per kW = <math>285</math> mol/CV h <math>\cdot 22,4</math> l/mol = <math>6384</math> l/kW h = <math>6,4</math> m<sup>3</sup>/kW h</li> </ul>					
$pV = nRT$ si ha che $\Rightarrow$ $V \propto T$ e quindi $V_2 = V_1 \cdot T_2 / T_1$					
<b>Fume production per hour with 200 °C, 0,1 MPa</b>					



$$\text{per CV} = 4,7 \text{ m}^3/\text{CV h} \cdot 473 \text{ K} / 273 \text{ K} \approx \underline{8 \text{ m}^3/\text{CV h}}$$

$$\text{per kW} = 6,4 \text{ m}^3/\text{kW h} \cdot 473 \text{ K} / 273 \text{ K} \approx \underline{11 \text{ m}^3/\text{kW h}}$$

**Fume production per hour with 200 °C, 0,1 MPa and power engine of 300 kW**

$$11 \text{ m}^3/\text{kW h} \cdot 300 \text{ kW} \approx \underline{3600 \text{ m}^3/\text{h}}$$

**Fume production per hour with 3 machineries (2 dumpers and 1 loader)**

$$3600 \text{ m}^3/\text{h} \cdot 3 \approx \underline{10800 \text{ m}^3/\text{h}} \approx \underline{3 \text{ m}^3/\text{s}}$$

The volume of fumes produced by the machineries is characterised, according to the state of the combustion, by different concentrations of compounds with high noxiousness, such as nitrogen oxides (NO<sub>x</sub>) and carbon oxides (CO and CO<sub>2</sub>); the different Threshold Limit Values to be observed during the work shift (TLV-TWA) have been identified by ACGHI (American Conference of Governmental Industrial Hygienist, 2011) and are summarised in the following tables<sup>17</sup>:

<i>Substance [n° CAS] (publishing date)</i>	<i>TLV-TWA</i>
Carbon Dioxide [124-38-9] (1983)	5,000 ppm
Carbon Monoxide [630-08-0] (1989)	1 ppm
Nitrogen Oxide [10102-43-9] (1992)	25 ppm
Particulate Matter (provided that no substances 10 mg/m <sup>3</sup> (inhalable) with an applicable TLV are present ( <sup>18</sup> ))	3 mg/m <sup>3</sup> (respirable)

*Table 1: A.C.G.I.H. - (2012) Threshold Limit Values (TLV-TWA)*

<i>Substance</i>	<i>PEL</i>
Total Carbon (D <sub>50</sub> = 0,2 µm)	160 µg/m <sup>3</sup>

*Table 8.11: M.S.H.A. (2008) DPM (Diesel Particulate Matter) in underground mining operations Permissible Exposure Level (8-hour time weighted average exposure)*

To ensure the proper ventilation of the underground, taking into account both the production of fumes per hour and the natural ventilation to face in some seasonal situations, it should be necessary to install an axial fan with a working prevalence

<sup>17</sup> It should be noted that the "ppm" (parts per million) is equal in value to 1 mg / kg; since it was assumed in the carried out fluid dynamic calculations that the density ρ is characterised by an approximate value of 1, 1 kg/m<sup>3</sup>, 1 ppm ≈ 1 mg / m<sup>3</sup>.

<sup>18</sup> The presence of crystalline silica is systematically monitored by the quarry technicians, and the Author were informed that it is play a critical role in the ventilation flow rate definition, in comparison with the diesel fumes.

values between 1000 to 3000 Pa (100 and 300 mmH<sub>2</sub>O), providing flow values between 50 to 70 m<sup>3</sup>/s (180000 and 252000 m<sup>3</sup>/h).

In the chart 8.12 it is shown a optimum working point of the axial fan taking into account the exploitation method.

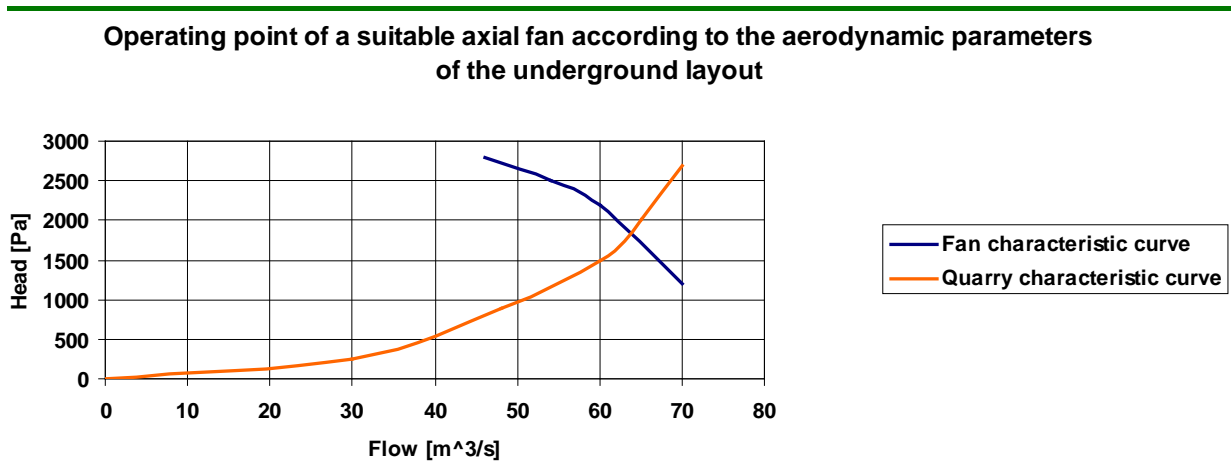

*Chart 8.12: Operating point a suitable axial fan according to the aerodynamic parameters of the underground layout.*



*Figures 8.13 and 8.14: Axial fan adopted.*

The choice of a ventilation system apparently overestimated, it is justified by the recent results of epidemiological studies related to the issues of free crystalline silica dust ( $\alpha$ -quartz and cristobalite); it is still uncertain the relation between cancer lung and the silicosis illness. Nevertheless, the A.C.G.H.I suggests the Threshold Limit Value (TLV-TWA) of 0.025 mg/m<sup>3</sup>. for this substance.

## **8.5 THE HAZARD IDENTIFICATION TECHNIQUE SELECTED TO EVALUATE THE AVAILABILITY OF THE SYSTEM**

According to the results of research work carried out by the Authors (Bersano et al., 2011), the Hazard and Operability Analysis (HAZOP) and the Fault Tree Analysis (FTA) techniques have been employed in combination to identify and analyse the criticality of ventilation systems in underground operations.

Moreover, an investigation on the failure probabilities of the different components of a ventilation system should be started, to collect numerical data usable in the provisional failure evaluations.

### 8.5.1 HAZOP – Hazard and Operability Analysis

The first step of the Hazard Identification was the implementation of a systematic analysis HAZOP on the complex ventilation - detection, to highlight the possible deviations, put in evidence the unwanted events (Top Events) and draft a hierarchical order of the criticalities.

The more critical event identified was the rapid filling of smoke of some areas of the underground due to a fire accident not correctly managed by the ventilation system.

		<i>Process</i>	<i>Parameter</i>	<i>Deviation</i>	<i>Cause</i>	<i>Effects (worst credible case)</i>
	clean air input	air flow in underground	clean air	No	Ventilation actuators failure	Rapid filling of smoke not faced by the ventilation system
	working face	air flow in underground	clean air	Less	Improper response of the ventilation to an emergency alarm	Filling of smoke not completely contrasted by the ventilation
	ventilation fan	polluted air exhaust	polluted air	More	Improper response of the ventilation to an emergency alarm	A not particularly critical situation, provided that correct organisation and, if necessary, rescue chambers are available

Table 8.15: The HAZOP analysis is based upon the process variables

### 8.5.2 FTA – Fault Tree analysis

To analyse the qualitative interactions among the identified initiator Events, the FTA technique was used. The Top Event the being a rapid filling of smoke in some underground areas.

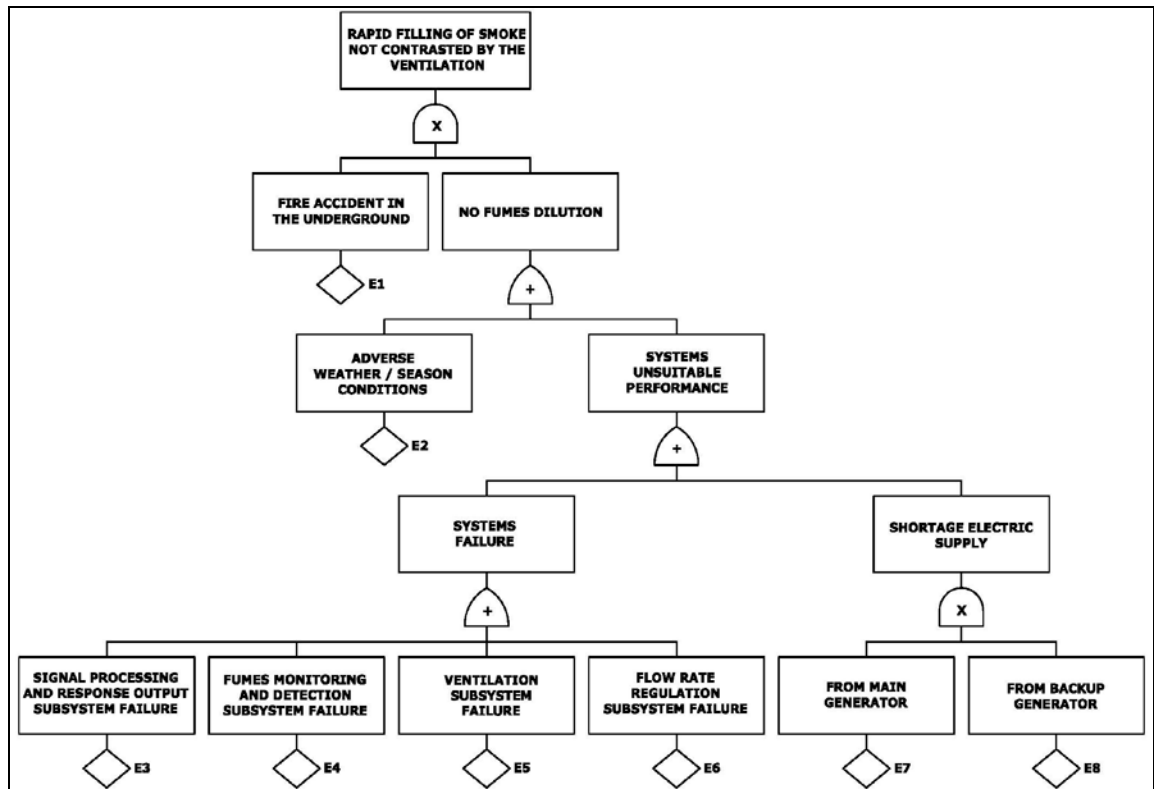
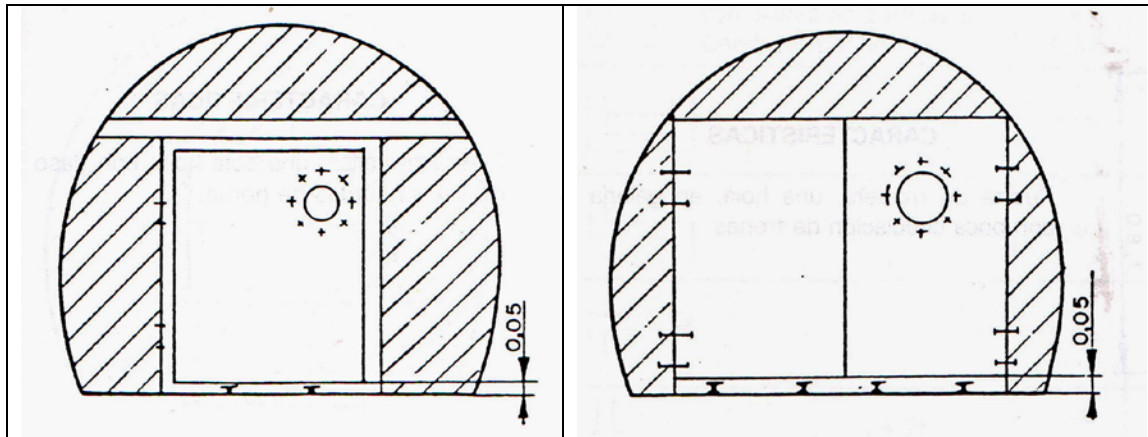

Figure 8.16: Qualitative Fault Tree Analysis of the ventilation system.

The qualitative FTA confirmed the importance of maintenance, organisation and management strategies, strictly indispensable in any sector and without which the analysis of the availability of mechanical components becomes useless.

### 8.6 THE VENTILATION FACILITIES

Adopting an ascending airflow (and in general the proposed ventilation configuration) requires to install a system with a double door to allow the passage due to the difference in pressure between. The distance between the two double doors and their size is a function of the type of means it is necessary to allow the travel.



Figures 8.17 and 8.18: double door able to take in to the fan duct

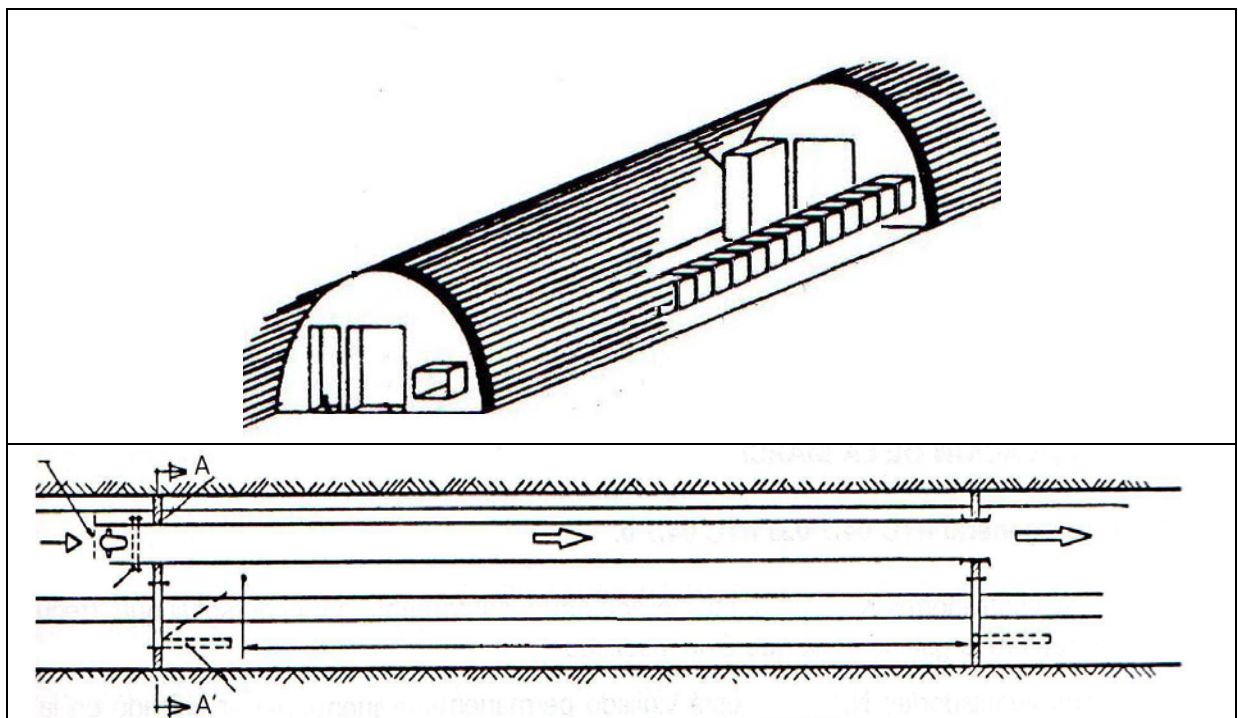

Figures 8.19 and 8.20: Plan and section of suitable layout of the double door to install the ventilation system

According to the approach that the problem must always be faced finding the risk minimisation of fire, ensuring the control of the fumes of the trucks and machineries, it should be adopted in the entrance tunnel at 1490 m an automatic detection and extinction system.

### 8.7 THE RESIDUAL RISK

However, the residual risk which the planned solution cannot manage (e.g. a fire at the level 1490 m.), could be avoided with other facilities to ensure the Safety of the personnel in every conditions.



- ❑ Fire alarm provided at all underground levels;
- ❑ Fixed “rescue chambers” at every level and mobile “rescue chambers” located near the current operations.

The proposed solution should be able to provide the right protection against flames but especially against the fumes and the heat that arise after a possible fire; the case of the structure will then have specific mechanical properties to properly face the inducted stress and the room will have to be equipped with an independent supply of compressed air and with an dioxide absorber with carbon filter so that to ensure the survival of the operators until the arrival of the rescue teams.

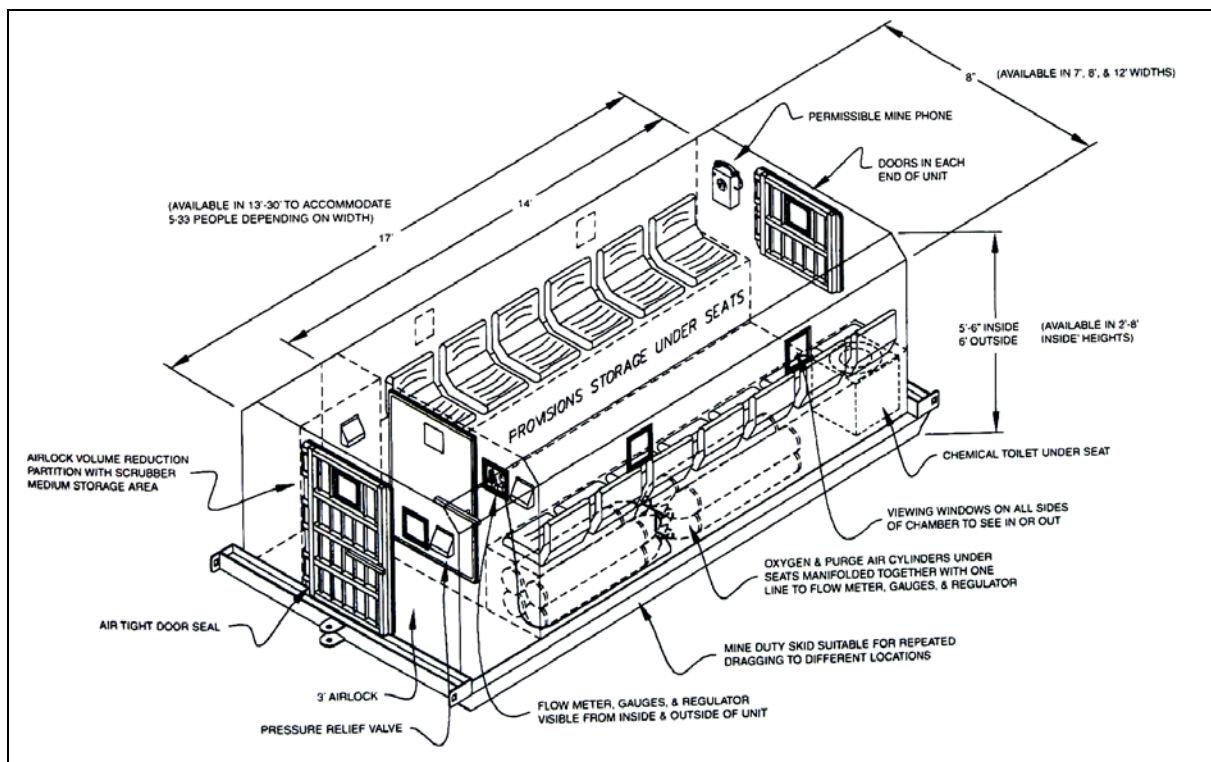

Figure 8.21: Inside view of a “rescue chamber” (such configuration is referred to the “Kennedy Rescue Chamber”).

In addition, the structure will have to work in "active pressure" mode; it means that the room will have an internal pressure greater (at least 100 Pa) than the environment pressure to not allow the entrance of the gases generated by the fire to inside.

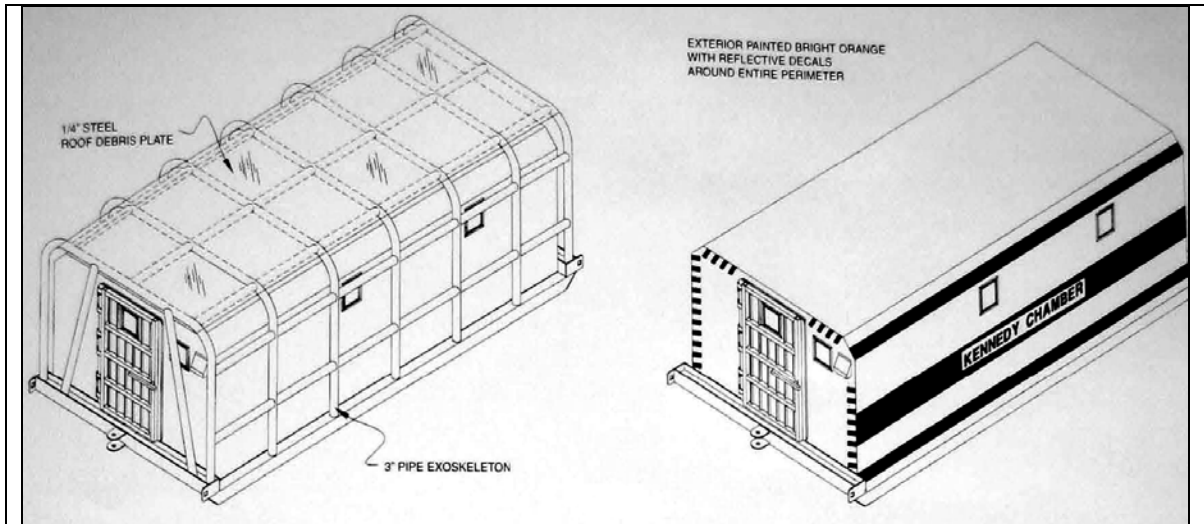

Figure 8.22: Case of a “rescue chamber” (such configuration is referred to the “Kennedy Rescue Chamber”).

The mobile features of this rescue system allows a rapid movement and a precious positioning next to the most critical operations, such as the tunnel tracking and the level’s exploitation, minimising the distance to walk by the operators in emergency situation.



Figures 8.23 and 8.24: Mobile “rescue chamber” built by the German company “Dräger”.

Instead of the mobile "rescue chamber", the niches in the rock should be adopted. Their features have to be comparable with the protection provided by a mobile “rescue chamber” and their location should be studied with particular attention so that they can perform the right function not only during level exploitation, but also, and especially,

during the tunnel tracking excavation in which there is no dedicated way to escape for the workers and there is no a proper airway for the fumes resulting from a possible fire.

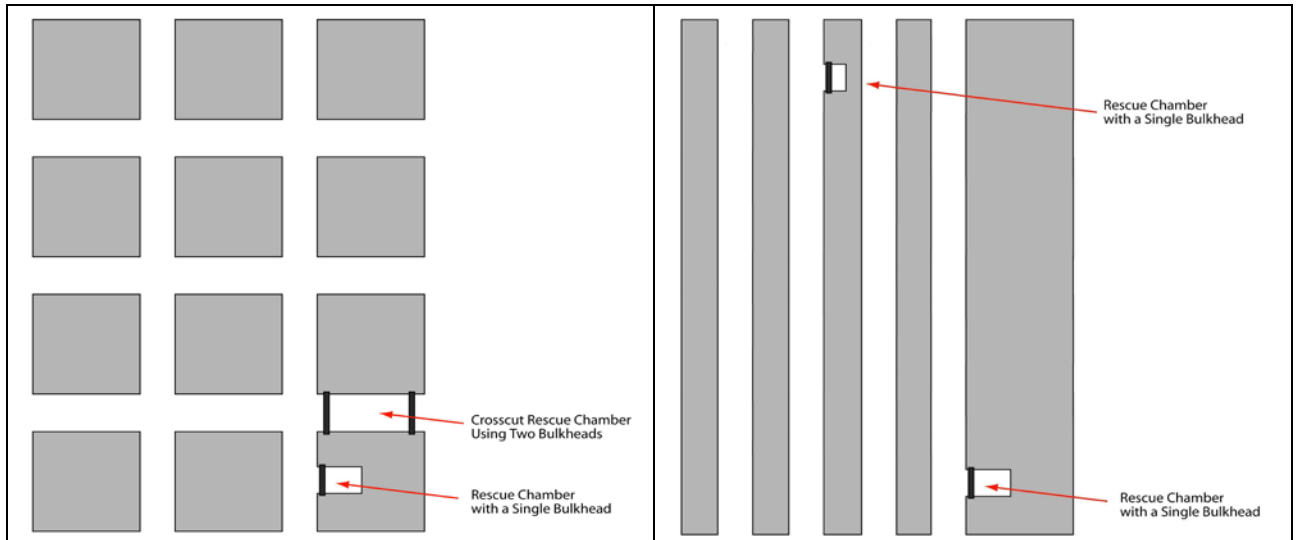

Figures 8.25 and 8.26: Different “rescue chamber” for the exploitation layout rooms-pillars (left) and rooms-walls (right).

The realization of such fixed “rescue chambers” can take place with different operating modes (which necessary involve different kind of materials) as far as the protection features and the technical characteristics provided can be preserved; the ability to maintain its mechanical behavior under the action of fire; the hermetic seal so that it prevents the passage of flames and fumes; the thermal separation to reduce the transmission of heat.

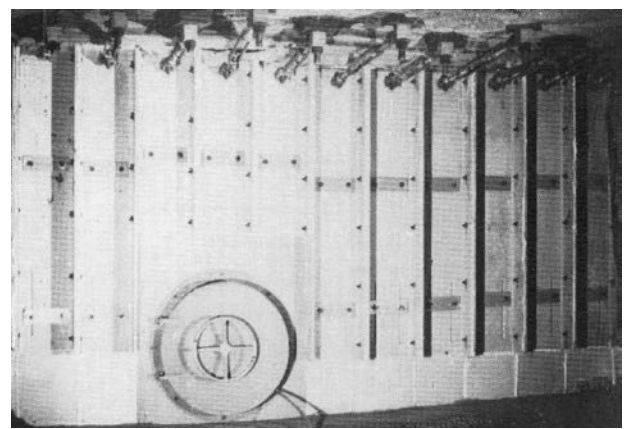
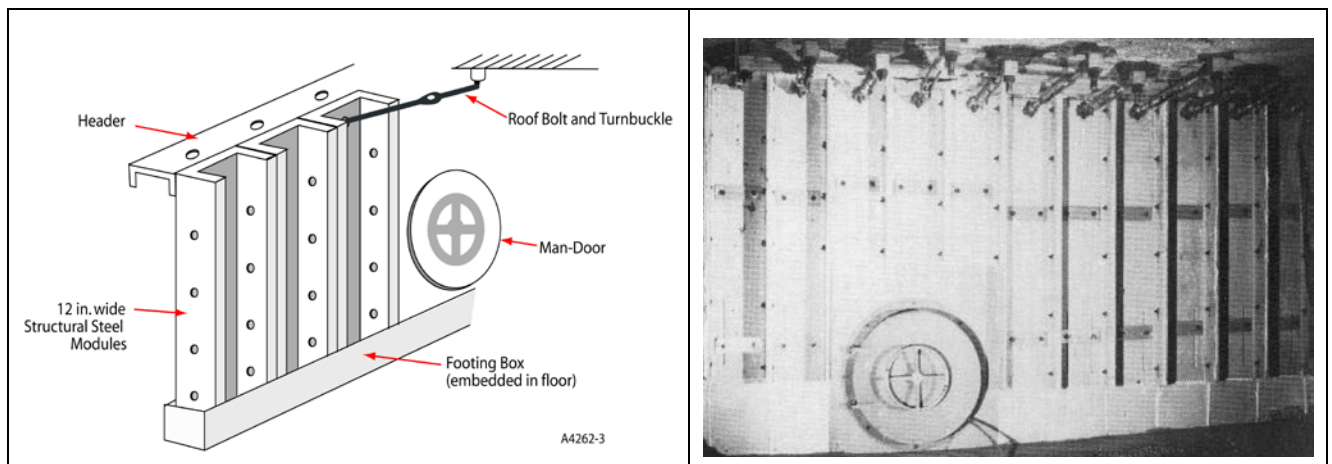

Figures 8.27 and 8.28: “rescue chamber” built in rock with steel modules and joined to the top with bolts.



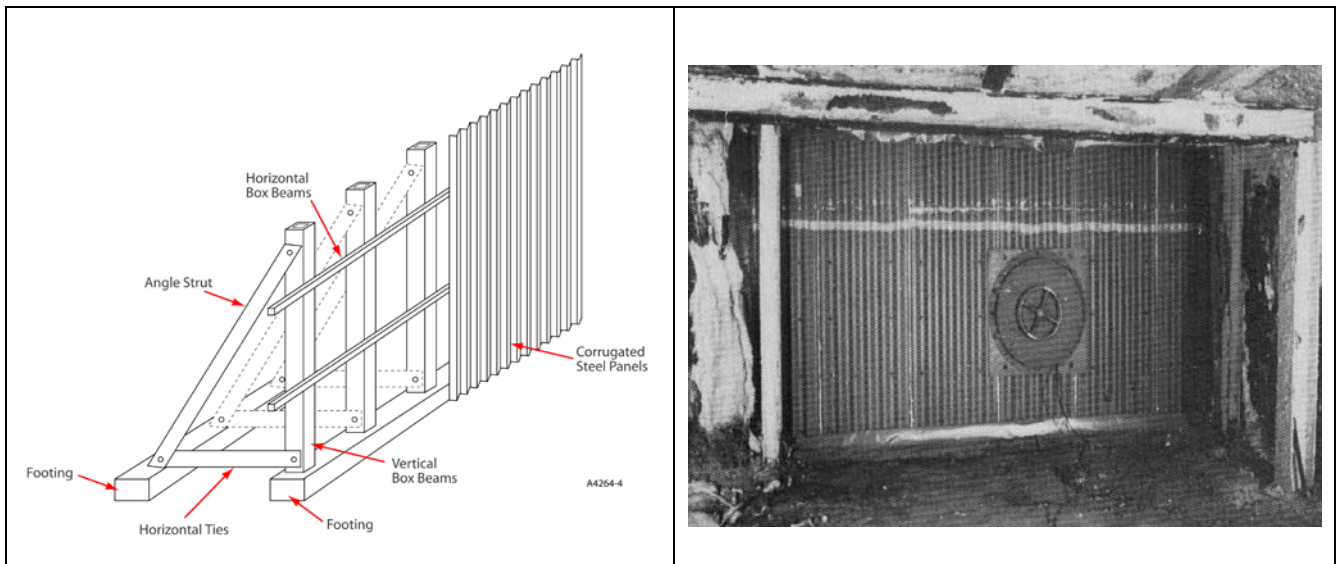

Figures 8.29 and 8.30: Wall of “rescue chamber” built corrugated steel panels and steel elements.

The “rescue chamber” (realized inside of the rock mass or mobile), must therefore, as underlined above, have to respect some fundamental characteristics that make them able to provide a safe place in case of emergency to the workers in the underground environment.

The main features are resumed in the table below:

### MAIN FEATURES OF RESCUE CHAMBER

- |  |  |
|--|--|
| ❑ Compressed air system                    | ❑ CO <sub>2</sub> picking-up system                              |
| ❑ Positive pressure valve                  | ❑ Communication system   |
| ❑ Airtight door for fumes, flames and heat | ❑ First AID equipment  |
|  | ❑ Indispensable articles (cigarettes, newspapers, play cards...) |

## References

- American Conference of Governmental Industrial Hygienist, 2012, Threshold limit values for chemical substances an physical agents & biological exposure indices, Signature Publications, Cincinnati, Ohio.
- Baum H., Floyd J., Hostikka S., McGrattan K., Rehm R., 2007,. Fire Dynamics Simulator (Version 5), Technical Reference Guide, National nstitute of standards and Technology.
- Berry P., DeVirgilio F, Patrucco M., Sammarco O., 1993, The emission of fumes from blasted rock in underground mines: a case study in Italy, proceeding for International Conference Mine Safe 1993, Perth, Australia, 47-52.
- Bersano D., Cigna C., Patrucco M., Pession J.M., Ariano P.F., Prato S., Romano R., Scioldo G., 2010, Extractive activities start up and management: a computer assisted specially developed “Prevention through Design” approach, International Journal of Mining, Reclamation and Environment, 24 Issue 2, 124-137, DOI: 10.1080/17480930903003680.
- Bersano D., Labagnara D., Patrucco M., Pellegrino V., 2011, Affidabilità: la “Cenerentola” nella progettazione degli impianti di ventilazione in galleria, GEAM Georingegneria ambientale e mineraria, XLVIII 133, 17-26.
- Borchiellini R., Colella F., Rein G., Verda V., 2011, One-dimensional and multi-scale modelling of tunnel ventilation and fires, Handbook of Tunnel Fire Safety, Second Edition, Beard and Carvel Editors.
- Mine Safety and Health Administration (MSHA), 2008, Diesel Particulate Matter Exposure of Underground Metal and Nonmetal Miners <[www.msha.gov/30cfr/57.5060.htm](http://www.msha.gov/30cfr/57.5060.htm)> accessed 05.02.2013.
- National Institute of Standards and Technology (NIST), 2010, FDS and Smokeview <[www.nist.gov/el/fire\\_research/fds\\_smokeview.cfm](http://www.nist.gov/el/fire_research/fds_smokeview.cfm)> accessed 05.02.2013.



*Contents*

*Start of the  
Chapter*



## CHAPTER 9: THE PREVENTION THROUGH DESIGN APPROACH IN THE MINING ACTIVITIES

*...come uno che, per strada deserta cammina tra paura e terrore e, guardandosi indietro, prosegue e non volta mai più la testa perché sa che un orrendo demonio a breve distanza lo insegue.*

*S.T. Coleridge*

### **THE PROBLEM: Why a Prevention through Design approach?**

The task of an effective Risk Analysis and Management at the extractive sites, coherent to the statements of the European regulations seen in the previous chapters, upon which the activity plan and development should be based, involves surely a pro-active approach, taken into account:

- ✓ *the paramount criticality of the extractive activities in terms of work related accidents (number and seriousness) and health impairments,*
- ✓ *the results of the recent epidemiologic surveys, in particular with reference to the possible criticality of the silica dust,*
- ✓ *the impressive developments in the geotechnics – geomechanic sciences, and in the mining techniques and technologies, which substantially modified the overall Safety situation.*

In such a situation the pro-active approach requires a thorough risk analysis based on careful evaluations of the possible project options and on a preliminary detailed knowledge of the site situation and scheduled operations, both by the Employer and the Mining Inspectorate technicians, since slapdash remedies and occasional inspections are

clearly inadequate to effectively highlight and control the underlying Safety criticalities typical of a complex activity.

A quite interesting improvement is here explained, recently set up in cooperation with the Local Mining Authority of the Provincia di Torino, based on the realization of a computer assisted interactive recording technique, able to support the analysts - industrial technicians, consultants and inspectors- in the evaluation of both the general and special Safety aspects, starting from the very first plan phase, up to the evolving development steps, taken into account the Risk Analysis improvements and revisions.

## **9.1 THE FOUNDING PRINCIPLES**

As well discussed in chapter 1, the Italian regulations on the Safety and Health of workers at work, directly drawn from the 89/391 EEC Directive, introduce the risk analysis as a mandatory task for the employer. Where the extractive operations are considered, taken into account their paramount criticality in terms of accidents (in number and seriousness) and of correlated health impairments, a special "daughter" regulation should be applied -derived from 92/91 and 92/104 EEC Directives- which integrates the main directive statements with further detailed clauses, and imposes a special Safety and Health Document to be drawn, and carefully kept up to date, covering the relevant requirements laid down in Articles 6, 9 and 10 of the 89/391 EEC Directive.

To properly fulfill the aforesaid requirements, the Safety and Health aspects should be taken in due account at the very first step of the activity design, and during the following developments, preferably in a quality approach according to the OHSAS 18000/07 standards (as explained above).

The special Italian regulation for extractive industries charges the Local Mining Inspectorates offices of the task of verifying both the mining plan, an official approval being required before the very activity start up, and the Safety and Health Document, and to carry out routine inspections on the Safety conditions at workplaces during the mining operations.

Taken into account the results of the recent epidemiologic surveys, the task of an effective Risk Analysis, upon which the activity plan and management should be based, involves a pro-active approach. Only such an attitude makes it possible to produce positive results, since slapdash remedies and occasional inspections are clearly

inadequate to effectively highlight and control the underlying Safety criticalities typical of a complex activity.

The approach, is already successfully tested at several quarrying sites with a preliminary analysis of the general aspects -documentation and operation practices- of Safety and Health, at each production site.

As mentioned in the Chapters 2 and 3, the extractive activities proved in the last years to be of paramount criticality where workers' Safety and Health are considered, as it can be observed in the following statistical tables (Figure 9.1).

It must in particular be underlined that the aforesaid *Frequency Index* confirms the previous assumption, even if in the aforesaid activities the number of invalidating and fatal injuries and health impairments is apparently low when compared with the overall national data.

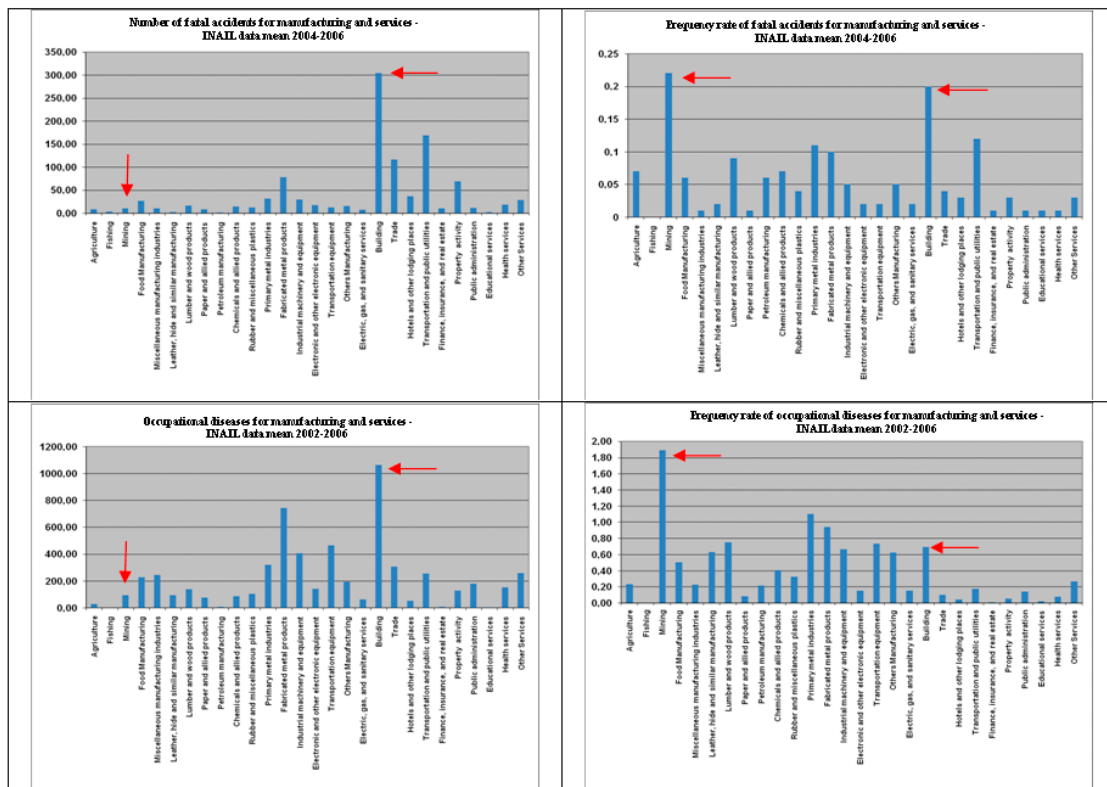

Figures 9.1: Injuries and occupational diseases for different productive sectors: absolute numbers and frequency indexes.

The statistical data definitely highlights the need of proactive action, but it is quite obvious that:

- a - the information drawn from the yearly recorded occurrences cannot be effectively used to infer reliable predictions of future accidents upon which to base Risk Analysis and inspection schedules (see figures and ), due to:

- a frequently insignificant consistence of the data base, in particular in industrial sectors with low occupational relevance –this being the case of Italian extractive activities- and, even more so, where such an analysis is applied at a local scale;

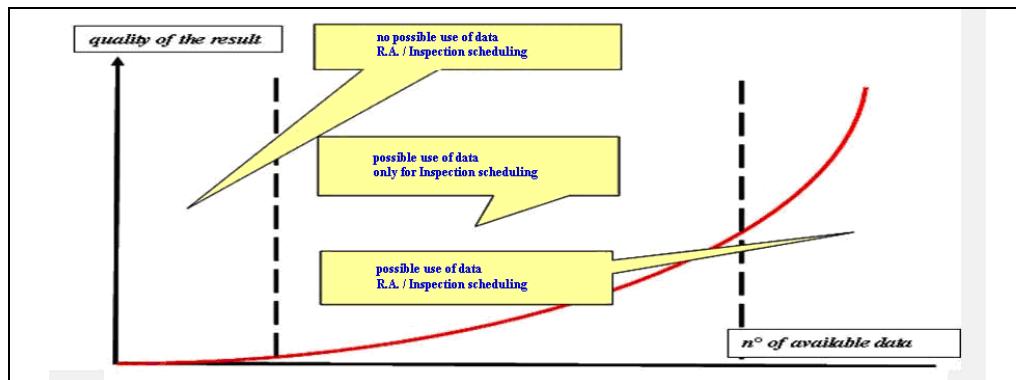

Figure 9.2: Possible use of statistical data vs sample size.

- a great difficulty in the evaluation of the parameters conditioning the Safety situations (e.g. economic and market conditions, expansion or contraction of industrial sectors and single firms, employment level and stability evolution, etc.).

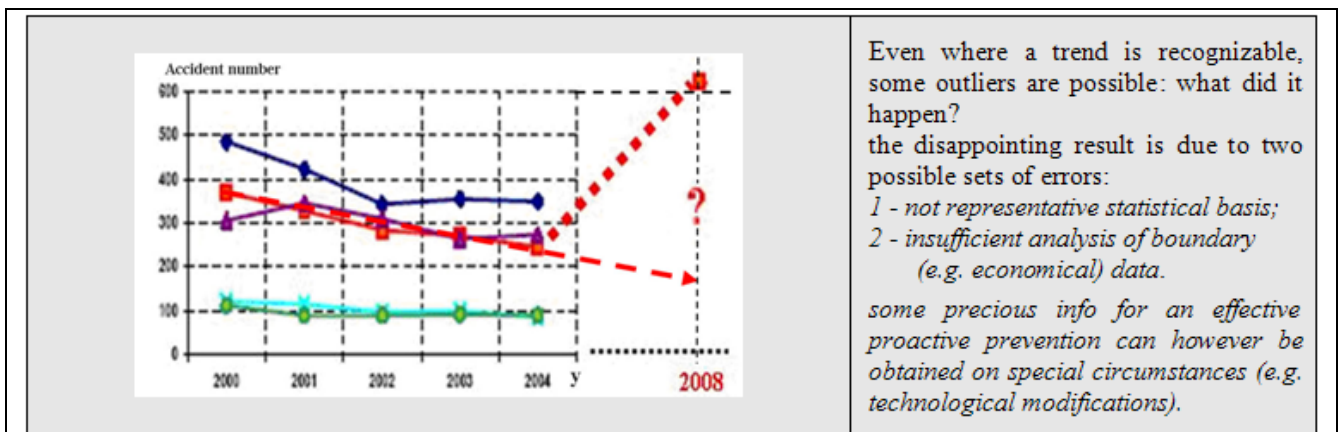

Figure 9.3: Possibility of forecasting the evolution of statistical trends.

b - only an in deep analysis of the occurred events would be of greatest importance to make available exhaustive information on the causes laying at the very heart of the event, and hence to properly identify the corrective actions to be adopted.

Unfortunately, such an approach is till now not supported by the Italian official statistics; these do not provide sufficient detail, in particular with reference to the violations of up to date Safety standards associated to work related injuries and health impairment recorded cases.

As a consequence, no general considerations useful for an effective preventive action can at present be drawn on this basis, neither to organise official inspections, nor to

correctly manage the residual risk in operative conditions accomplishing to the Safety regulations, in compliance to the statements of the Italian enforcement of the 89/391 EEC Directive on the introduction of measures to encourage improvements in the Safety and health of workers at work<sup>19</sup>.

In spite of the aforesaid difficulties, some significant results can be drawn on the basis of a number of analyses carried out on Court appointment<sup>20</sup>, and the following embedded primary causes both of fatal and major accidents and of critical work related health impairments can be listed in order of importance as in the Figure 9.4

1. lacking identification of the Risk factors (reasonably predictable deviations included)	<i>a "simplified" approach in this very critical phase has the obvious consequence that some risk come be tout court neglected, and no risk management action is carried into effect</i>
2. lacking Risk Evaluation	<i>an incorrect hierarchy in the Risk Evaluation can introduce dramatic underestimates of the real criticalities, and, therefore, insufficient control measures</i>
3.1. lacking internal/external audit of operations development as resulting from the Risk Analysis	<i>an effective supervising of on the various operations correctly planned and verified in the preliminary Risk Analysis and of the modus operandi in accordance with correct and detailed procedures can obviously reduce the criticalities. Nevertheless, a quite poor management of the work S&amp;H basics during the mining operations can sometimes be observed, often disregarding even the statements introduced in the 'Safety and Health document' (ref. 92/104/EEC Directive). Training and Education should be specially defined for each task according to the results of Risk Analysis and Management, and systematically enforced. This cause of accidents is progressively INCREASING, partly due to a new approach in jobbing contracts, involving poor T&amp;E [3]</i>
3.2. lacking conservation in the time of the technical measures as resulting from the Risk Analysis.	<i>poor care or contingent industrial problems may cause a faulty attention to the maintenance and preservation of the efficiency of the technical control measures introduced as a result of Risk Management activities.</i>
3.3. lacking Risk Analysis revision in case of changes in the industrial scenery (plants/materials/operations)	<i>every modification in the productive and operating conditions should obviously be designed taking into due account a revision of the Risk Analysis and Management.</i>

*Figure 9.4: Primary causes of fatal and major injuries.*

The aforesaid statement is clearly corroborated by data from the U.S. Department of Labor Mine Safety and Health Agency (M.S.H.A.), that provides detailed info about indirect causes in the data collection for the drafting of injuries and occupational diseases statistics, therefore leading to an effective possibility of use of the data for prevention (see fig. and ).

<sup>19</sup> obviously a basic reference for every industrial activity, the critical ones, regulated by special "daughter Directives", included, as is the case of the extractive activities:

❑ *Council Directive 92/91/EEC concerning the minimum requirements for improving the Safety and health protection of workers in the mineral-extracting industries through drilling (eleventh individual Directive within the meaning of Article 16 (1) of Directive 89/391/EEC).*

❑ *Council Directive 92/104/EEC on the minimum requirements for improving the Safety and health protection of workers in surface and underground mineral- extracting industries (twelfth individual Directive within the meaning of Article 16 (1) of Directive 89/391/EEC).*

<sup>20</sup> on the basis of this experience a special computer aided approach was developed with the aim of investigate secondary causes of fatalities and serious injuries [2]



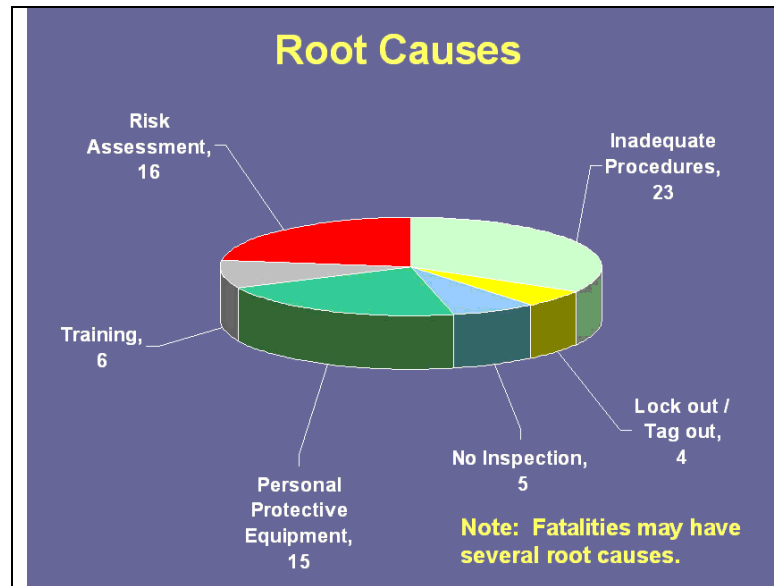

Figure 9.5: Risk analysis related causes of fatal injuries<sup>21</sup>

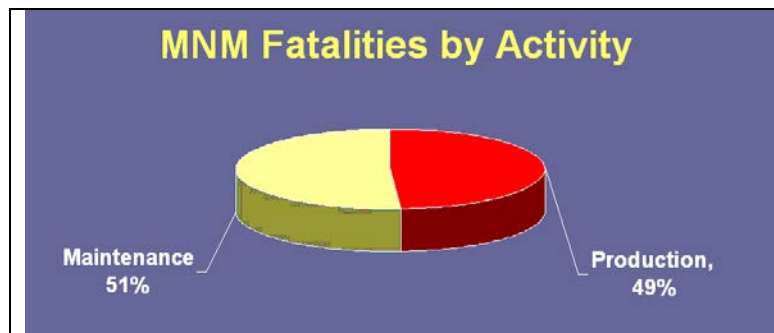

Figure 9.6: Tasks involved in fatal injuries .

From the aforesaid scenario it is demonstrable that:

1. a poor risk analysis and management obviously involves inadequate procedures, poor training and education, and insufficient internal/external audits;
2. where special tasks –e.g. maintenance related- are not in deep analysed, fatal errors can occur due to incorrect planning and execution.

Summarising, it must be strongly stated that the most important cause of both fatal injuries and health impairments of workers at workplaces should be managed by a “Prevention through Design” approach, where the Safety and Health aspects are considered since the very first feasibility and design steps, avoiding the obvious consequence of a series of compromises and a poor Safety level. Besides, special care is necessary among the insite activities, to grant the conservation / improvement of the Safety measures decided during the design phases. Such an approach, nowadays widely

<sup>21</sup> NOTE: "Lockout/Tagout (LOTO)" refers to specific practices and procedures to safeguard employees from the unexpected energization or startup of machinery and equipment, or the release of hazardous energy during service or maintenance activities.



recommended, is at the base of the EU Safety standards (Figure 9.7, drawn from a EEC analysis, exemplifies the cost/error evolution vs time)

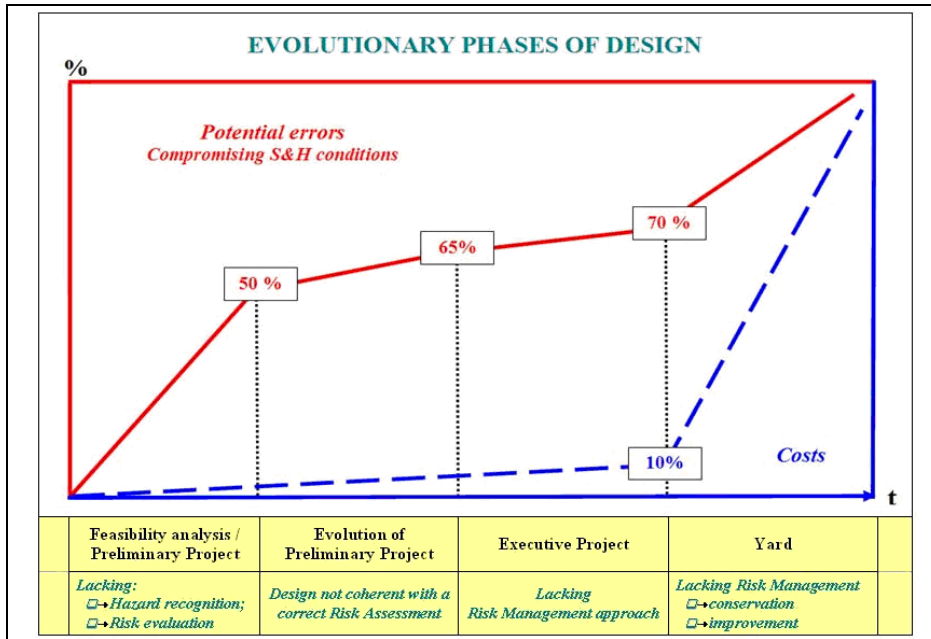

Figure 9.7: Time evolution of costs / errors.

## 9.2 THE METHOD: THE BASIC APPROACH OF THE PROPOSED RISK ANALYSIS AND MANAGEMENT TECHNIQUE

Basically, the best mining situation can be achieved only where an effective General Risk Analysis is correctly performed, the Sustainable Development itself being the result of such an approach.

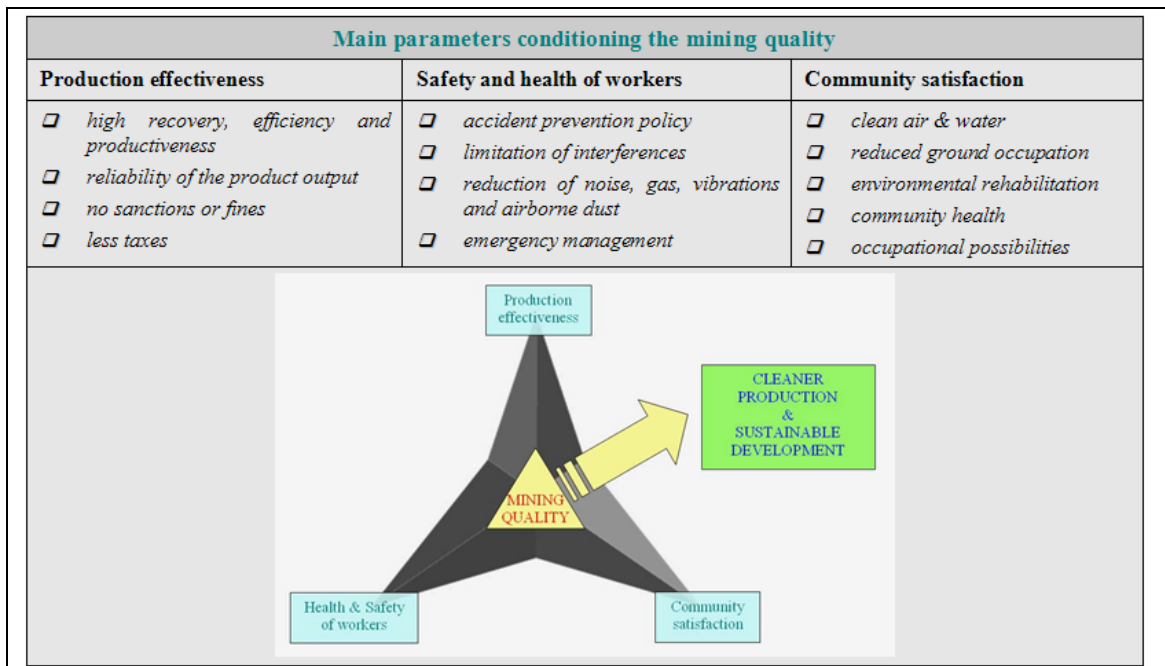

Figure 9.8: Main parameters conditioning the mining quality.

Moreover, Safety and Health of workers should be considered a key topic not only from an ethical point of view, but also where the overall mine effectiveness is taken into account, since accidents and health impairments dramatically affect both the direct and indirect costs of production.

The main results achieved in order to provide a well-tested guideline for an effective approach to the Risk Analysis and Management were presented in the 1996 - S.H.C.M.O.E.I -Safety and Health Commission for the Mining and Other Extractive Industries- Workshop on Risk Assessment, and are published in the Official Documents Gazette of Lombardia Region (BURL 2002, n.8, Annex 2 2002). It must be underlined that, even if originally developed for mining and earthmoving activities, the approach was successfully adopted in a quite large number of different industrial typologies.

The aforesaid well tested approach was substantially improved thanks to a computer assisted interactive recording technique, able to support the analysts -industrial technicians, consultants and inspectors- in the evaluation of both the general and special Safety aspects, starting from the very first plan phase, up to the evolving development steps, taken into account the Risk Analysis improvements and revisions.

In the following figures the basics of the main screenshots (data input –Figure 9.10 - and result output –Figure 9.11) and of some software pages are provided. It must be underlined that the pages can be freely scrolled even if some input data are missing, the empty lines acting as a memo, so that they can be completed later, the target being an exhaustive document suitable for the Official approval and the periodic revisions.



Figure 9.9: Computer-assisted technique developed in Prevention through Design

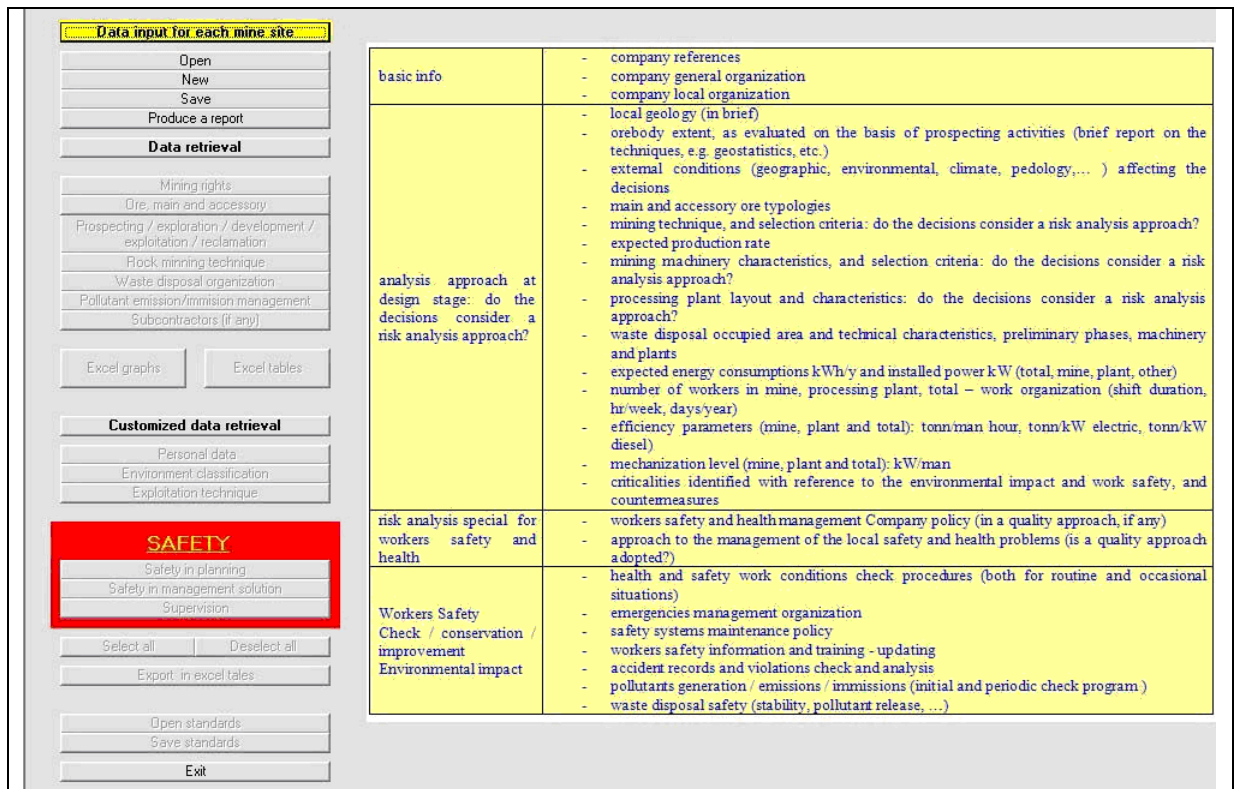

Figure 9.10: Data input features: main input screen.

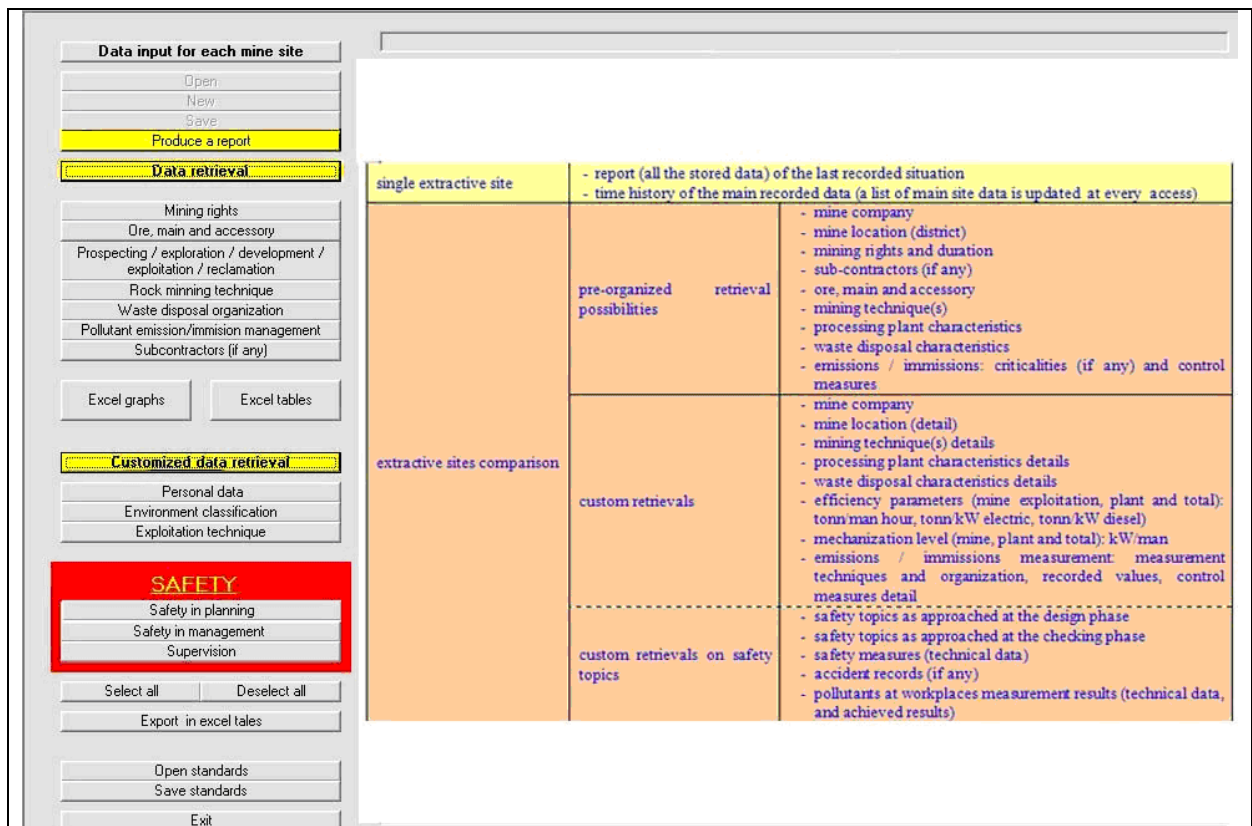

Figure 9.11: Data output screen: main output screen.

## **9.3 THE SOFTWARE DESIGN**

### **9.3.1 A short history of the software approach**

As soon as the very first approach to the analysis of different extractive site layouts and boundary conditions was completed, a number of additional parameters proved to be necessary for a detailed investigation: progressively, the archive grew to many hundreds of data sets, and it became clear how complex it would be to manage such an amount of data with a common Data sheet, so that the creation of a dedicated software became essential.

The software should prove able to manage as many different analysis types as possible, in order to identify the administrative data, and the potentially critical working situations requiring a proactive workers Safety approach, and careful Safety management/improvement during the exploitation phases.

It has then been decided to develop such a package with Microsoft Visual Basic® 6.0 Professional, since many procedures, especially related to the high quality graphic output and to the available export procedures to standard data formats were already available, and this could make our work significantly faster, saving time that could profitably be spent in the data structure analysis. In addition, such an approach grants full compatibility with the Italian Public Administration existing data bases, so that info import and export are quite easy.

### **9.3.2 An upgradable data structure**

The experience indicated that the best software solution

- to provide an effective Computer Assisted Decision Making, to verify the accomplishments of the project to the formal requirements
- to evaluate the Risk Analysis and Management approach,

would require an open structure, allowing the introduction of new parameters when needed, should this be the case in future.

Besides the simple typed alpha-numeric data collection, this software accepts and saves other useful information in many different document formats, such as pictures or pdf files: this feature shows the advantage of a remarkable completeness in the data collection and, at the same time, simplified the data input procedures.

To allow an high level data analysis, a remarkable effort has been devoted to make available for many of the involved parameters a large number of pre-defined selection

options, to avoid the risk of confusion due to the “fantasy” of each operator: a finite but exhaustive list of parameters removes the possibility that a single parameter, defined with different descriptors, could not be univocally recognized by the software.

Finally, particular care has been devoted to avoid incongruities among different input data: it is generally not a small problem, due to the quite strong interaction between different parameter sets: at the purpose, some limitations were introduced on the possibility of associating, for example, a certain kind of rock to an incompatible operative situation.

The final result is a quite complex software structure, in which simple lists have been replaced by nested or cross-referenced ones: as a result, the data input task can be performed even by relatively unskilled operators, since mistakes are automatically prevented by the system.

### **9.3.3 Extractive unit historical data**

One of the most interesting features of the software is the ability of tracking the historical evolution of each parameter, so that the exact situation of an extractive unit at each specified time of its life can be recovered, together with clear info about the modified parameters.

### **9.3.4. Powerful and flexible search criteria**

The important preliminary work done on the data structure provided quite good results in terms of flexibility of the search criteria, and the user-friendly interface makes the selection of any combination of parameters possible, both as selection criterion, and as required output.

A logical “AND” is applied to the selection, and multiple choices are possible for each parameter (e.g. it is possible to select all the extractive sites in a given geographical area, where two or more kinds of rock are mined). In this way it is possible to restrict the search, to tailor it to the exigencies of any particular historical or statistical analysis.

With reference to the parameter values, it is possible to set thresholds to select desired ranges (for example in terms of yearly production, number of workers, mechanization index, etc...).

Moreover, it is possible to refer the results of the search to every parameter.