

High frequency behavior of residual current devices

Original

High frequency behavior of residual current devices / Freschi, Fabio. - In: IEEE TRANSACTIONS ON POWER DELIVERY. - ISSN 0885-8977. - STAMPA. - 27:3(2012), pp. 1629-1635. [10.1109/TPWRD.2012.2191423]

Availability:

This version is available at: 11583/2497832 since:

Publisher:

IEEE

Published

DOI:10.1109/TPWRD.2012.2191423

Terms of use:

This article is made available under terms and conditions as specified in the corresponding bibliographic description in the repository

Publisher copyright

(Article begins on next page)

High frequency behavior of residual current devices

Fabio Freschi

Abstract—The purpose of the paper is to analyze the behavior of residual current devices at frequencies higher than the rated one. Many experiments are carried out by measuring tripping current and time of devices of different typology, produced by different manufacturers. The attention is mainly devoted to verify the satisfaction of the current-time safety curve at high frequency and experiment tripping and immunity to unwanted tripping in presence of harmonics. Conduced tests show that the behavior of residual current devices at high frequency is strongly influenced by their typology rather than the values assumed by their physical parameters. In addition, a mathematical model is developed and simulations are compared with measurements showing a satisfactory agreement in the whole frequency range under study.

Index Terms—Residual current device, frequency, harmonics.

I. INTRODUCTION

RESIDUAL current devices (RCDs) are circuit breakers that are able to automatically open the circuit where they are placed when the residual current due to a circuit failure is beyond a predefined threshold. The residual current is defined as the vectorial sum of all currents that flows through live conductors, neutral conductor included. These devices are also referred to as residual current circuit breakers, RCCBs [1], or ground-fault circuit interrupters, GFCIs [2]. RCDs are fundamentals components for safety against indirect contacts in low voltage installations and they improve safety in case of direct contact [3].

The behavior of RCDs is well known when the fault current is at the rated frequency of 50/60 Hz. Only a few studies consider RCDs operating at higher frequencies. The interest for high frequency performances can be motivated by the fact that some particular installations work at rated frequencies higher than standard 50/60 Hz (e.g. airport installations work at 400 Hz [4]). More common in nowadays installations is the presence of electronic switching converters to supply variable speed drives [5], ballasts for lighting, common mode filters that can cause significant protective conductor currents up to tens of kilohertz [6]. When considering the presence of frequencies higher than the fundamental one, three issues must be addressed in the working of RCDs:

- *tripping at frequencies different from the rated one*: the actual shape of the fault current is very complicated in real world applications, and the device must guarantee safety even in presence of high harmonics;
- *unwanted tripping*: high frequency residual currents must not trip the RCD when the conditions for tripping are not met;
- *blinding*: high frequency residual currents must not inhibit the correct behavior of RCDs at the rated frequency.

Some early works investigated the effects of harmonics on general equipment and protections [7], [8], [9], [10]. In [11], the author considered the nuisance tripping of RCDs due to over voltages and suggested some installation tricks in order to ensure maintenance of energy supply for non faulty circuits. In [12] two techniques are proposed to reduce vulnerability to the nuisance tripping: phase detection and time delay. In [13] the effects of harmonics on RCDs performances are investigated, highlighting the main parameters affecting the tripping characteristics of RCDs: phase shift of harmonics, transformer and relay time constants. In [1] authors reported some experiments on low sensitivity RCDs ($I_{\Delta n} > 30$ mA). Authors empirically discovered that when only a single harmonic is present, there is a critical percentage of harmonic-to-fundamental ratio such that the tripping current is minimum. This critical percentage decreases as the order of harmonic becomes higher. They also proposed a filter to be included in the RCD, obtaining a more stable tripping characteristic in presence of harmonics. A more detailed experimental protocol was adopted in [14] to test RCDs against harmonic ground fault and surge currents. Authors examined RCDs from one manufacturer. They found that in normal operation tripping is mainly caused by the peak value of current; in presence of harmonic it is necessary to limit leakage current in order to avoid unwanted tripping and under surge conditions, RCDs withstand only short duration currents. Finally, in [15] RCDs were tested for high harmonics up to 49th and results were compared with an *a-priori* qualitative analysis.

The purpose of this work is to analyze the behavior of high sensitivity RCDs when the fault current has higher frequency than the rated one and in presence of harmonic distortion. Low voltage, high sensitivity devices are produced by different manufacturers and many constructive typology are considered (AC, A with electronic board or resonance capacitors, see Section II. The aim of the experiments is to verify:

- the compliance of RCDs with the current-time safety curve with high frequency supply;
- tripping and immunity of RCDs in presence of harmonic distortion.

In addition, in order to make reproducible results and to be able to model different supply conditions, a mathematical model is developed and tuned with respect to measurements.

II. WORKING PRINCIPLE AND MATHEMATICAL MODEL

A RCD is basically made by three parts (Fig. 1): a *differential transformer*, an *electromechanical relay* and some *additional components* to perform signal conditioning between the other two.

The differential transformer is a high permeability magnetic core with one primary winding for each live (phase or neutral)

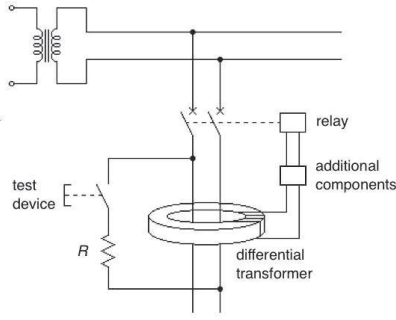

Fig. 1. Functional representation of a single-phase RCD.

conductor. In normal operation the vectorial sum (magnitude and phase) of all currents is zero. If there is an unbalanced condition due to a ground fault, a magnetic flux in the magnetic core is generated and an electromotive force is present in the secondary winding. The equivalent electric circuit can be built assuming negligible coil resistances (because conductors are short and have large cross section) and leakage inductances (because of high core permeability). By assuming normalized values with respect to the transformation ratio, the model is reduced to the magnetization inductance L_m and the iron losses resistance R_p (Fig. 3, red blocks).

The electromechanical relay has the role of converting electric into mechanical power in order to start the opening of the circuit breaker. Different manufacturers use different assembling schemes, but the working principle is common and can be explained by the scheme of Fig. 2. The permanent magnet (C) preloads the magnetic circuit (A) in order to maintain closed the floating anchor (B) by compensating the attractive force of the spring (D). In ordinary conditions, the floating anchor is attached to the magnetic circuit due to the attractive force originated by the magnetic flux of the permanent magnet. During fault conditions the coil (E) is energized. An alternated magnetic flux is superimposed to the DC flux of the magnet. During a half-wave, the two fluxes are opposed in sign and the total attractive force acting on the anchor is reduced. When the mechanic force of the spring exceeds the magnetic force, the anchor moves the release (F) and causes the tripping of the circuit breaker. The coil of the relay is taken into account by a series resistance R_S . The magnetic circuit of the relay is modeled by an inductance L_{relay} connected in parallel with the resistance R_{relay} that takes into account iron losses. The model provides for two different values for these parameters to consider relay in closed or open position (Fig. 3, blue block).

The connection between transformer and relay can be direct, but usually some *additional components* are present to improve the RCD performances. In order to avoid nuisance tripping, noise suppressors (e.g. anti-parallel connected diodes, zener diodes, ...) can be placed at the secondary of the differential transformer. They are neglected in this study, because they affect the behavior of the RCD only in case of over-voltages. On the contrary, the model contemplates the presence of resonance capacitors, because they drastically affect the RCD performances in ordinary conditions. These capacitors

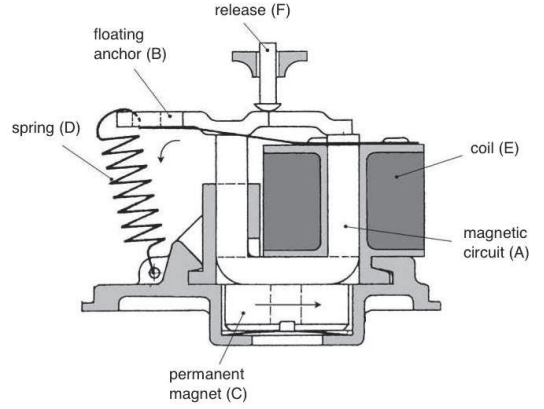

Fig. 2. Example of electromechanical relay: (A) magnetic circuit, (B) floating anchor, (C) permanent magnet, (D) traction spring, (E) coil, (F) mechanical release.

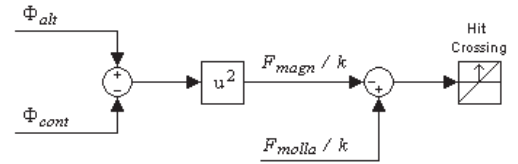

Fig. 4. Functional diagram of the detector block.

are tuned with respect to the relay inductance at around 50/60 Hz in order to decrease the overall impedance of the relay and increase its sensitivity to small currents. They can be connected in series and/or in parallel (Fig. 3, orange block).

A detector of the tripping condition and a mechanical delay are introduced to complete the RCD model (Fig. 3, grey block). The detector sums the magnetic flux due to permanent magnet and the one due the secondary current. The resultant magnetic force is proportional to the square of the resultant flux. When this value exceeds the mechanical force of the spring, the circuit breaker opens the main contacts after a specified delay. The functional diagram of the detector is shown in Fig. 4 and is embedded in the grey block of the complete model of an RCD of Fig. 3 built in Simulink [16].

A. Parameter assessment

The model of Fig. 3 requires the definition of some electrical parameters. These parameters can be obtained direct measurements of the RCD components. Differential transformer parameters are measured by a standard no-load test. The same test is repeated for the relay, by introducing a low distortion amplifier since the voltage value are a few percents of volts. Measurements are performed at a working point close to the opening of the relay and when the relay is open. The resistance of the relay coil is measured in DC. The tripping threshold and mechanical delay are regulated in order to fit the measured tripping current and the tripping time with the simulated ones.

III. MEASUREMENTS

Two classes of RCDs have been tested: AC and A type. According to IEC Standard 60755 [17], AC type ensure tripping

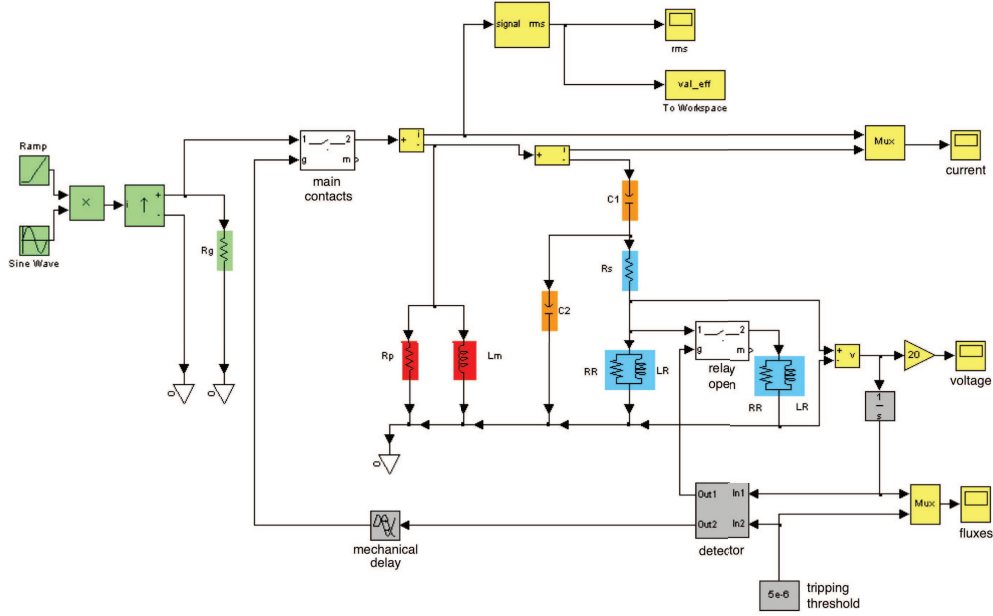

Fig. 3. Simulink model of the complete system: (green) residual current supply, (red) differential transformer, (blue) electromechanical relay, (red) resonance capacitors, (yellow) monitors, (grey) electromechanical block, (white) main contacts.

TABLE I
NUMBER AND TYPOLOGY OF TESTED DEVICES

manufac.	typology	symbol	quantity
A	AC, direct	AC/d	3
B	AC, direct	AC/d	2
	A, electronic	A/e	3
C	AC, direct	AC/d	2
	AC, direct	AC/d	4
D	A, electronic	A/e	2
	A, resonance capacitors	A/c	3

for residual sinusoidal alternating currents, whereas A type can operate also with pulsating direct currents. RCDs enrolled for the study are produced by four different manufacturers, indicated as A, B, C, D. The inclusions criteria for the selected devices are:

- A or AC types;
- instantaneous (not time delayed) tripping;
- single phase;
- combined with over current device;
- rated residual operating current of 30 mA;

Coupling between transformer and relay can be direct, by means of resonance capacitors or with an electronic board able to store energy. They are here identified with the lower-case letters d, c, e, respectively. Table I reports number and typology of tested RCDs. All RCDs are preliminary tested to confirm functionality on a regular basis: they tripped for a residual current in between $I_{\Delta n}/2$ and $I_{\Delta n}$ with gradually increasing current; break time for abrupt application of $I_{\Delta n}$ was not beyond 300 ms. Five experiments are implemented to verify the behavior of RCDs at high frequencies and with harmonic distortion:

- 1) opening transient;
- 2) residual operating current at high frequency;

- 3) tripping time at high frequency;
- 4) tripping in presence of third harmonic;
- 5) immunity to unwanted tripping.

During these experiments the operating current and the non-operating current are defined respectively as the maximum and the minimum tripping current among five consecutive experiments.

A. Frequency range definition

The purpose of RCD is to reduce the hazard of electric shock in case of a failure of the equipments basic insulation to ground [3]. For this reason the device must guarantee the automatic disconnection of supply according to the current-time safety curve defined in IEC Standard 60479-1 [18] for frequencies up to 100 Hz. This curve is asymptotic to the value of 30 mA: currents exceeding this threshold must be interrupted in a time compliant with the safety curve.

IEC Standard 60479-2 [19] suggests to account for the effects of frequencies higher than 50/60 Hz on the probability of ventricular fibrillation by means of the *frequency factor* F_f : the larger the frequency the lower the probability of fibrillation (see Table II, first two columns). By taking into account that in low voltage installations the rated line-to-ground voltage is usually lower than 230 V and the value of body resistance is always larger than 600 Ω [18], it comes out that the larger frequency of interest is 1000 Hz. In fact at 1000 Hz the threshold of the safety curve is $F_f = 14$:

$$30 \text{ mA} \cdot 14 = 420 \text{ mA}$$

while the maximum current that flows through the human body during a direct or indirect contact is

$$\frac{230 \text{ V}}{600 \Omega} = 383 \text{ mA}$$

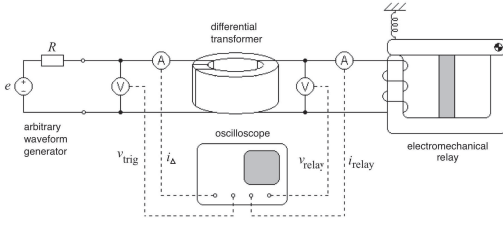

Fig. 5. Experimental setup for operating current measurement between 50 Hz and 1000 Hz.

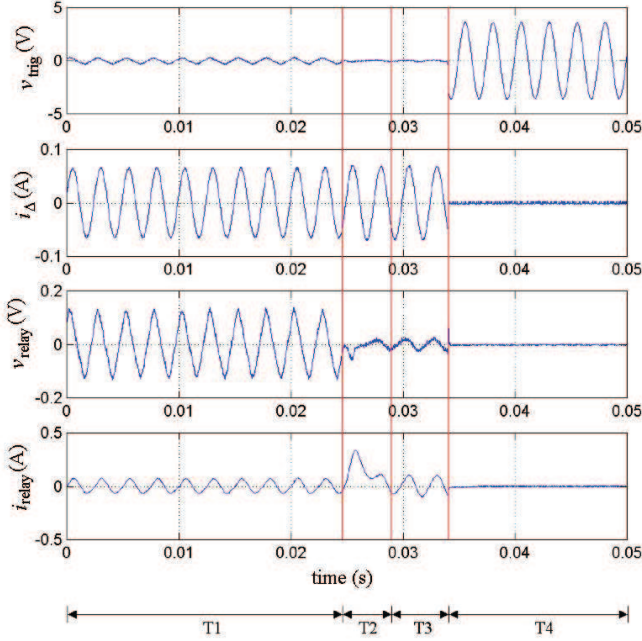

Fig. 6. Opening transient measured at 400 Hz for AC/d type of manufacturer A.

which is lower than the safety threshold. In the remainder of the paper, 1000 Hz will be considered the limit frequency for the analysis.

B. Opening transient

The opening transient is studied by setting up a measurement bench as sketched in Fig. 5. Measurements are related to the AC/d type of manufacturer A. An arbitrary waveform voltage generator is connected to one random pole of the breaker. Probes are inserted into the circuit by removing the RCD enclosure, taking care of preserving the functionality of the device. Four waveforms are recorded by a digital oscilloscope: residual operating current i_{Δ} , phase voltage (used to trigger recordings) v_{trig} , voltage v_{relay} and current i_{relay} that supply the relay. The transient phase corresponding to a frequency of 400 Hz is shown in Fig. 6. During the first phase (T1) the residual operating current is slowly increased until tripping conditions are met. The signal v_{trig} , that represents the voltage drop across a pole of the device, has the same shape of the voltage v_{relay} , rescaled by the voltage ratio of the differential transformer. The second phase (T2) starts with the movement of relay contacts. The air gap of the magnetic

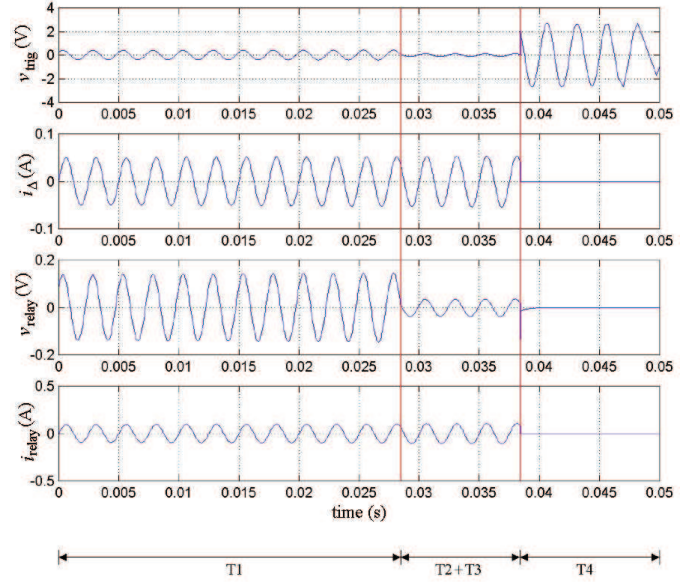

Fig. 7. Opening transient simulated at 400 Hz for AC/d type of manufacturer A.

circuit increases, increasing the total reluctance \mathcal{R} as well. Since the magnetic flux Φ is a state variable, its value must be continuous. To guarantee the feasibility of the identity:

$$\mathcal{R}\Phi = Ni_{\text{relay}}$$

the current i_{relay} must promptly increase to compensate the abrupt change of \mathcal{R} . During the phase (T3) a new steady state condition is reached: v_{relay} and i_{relay} assumes the values compatible with the new reluctance. The interval (T3) can be viewed as the mechanical delay required by the main contacts to open the circuit. When contacts are open (T4) the residual current i_{Δ} is suddenly interrupted. There is no evidence of electric arc phenomena, because i_{Δ} has low intensity.

The same device (AC/d type, manufacturer A) is then simulated by using the model described in Section II. Simulation results are reported in Fig. 7. Notwithstanding a reasonable good agreement between measurements and simulations, some structural discrepancies can be highlighted. The measured waveform of v_{relay} is distorted, due to the nonlinearity of the magnetic characteristic. Since parameters of the model are linear, this phenomenon is neglected in the simulations. Simulations do not provide any distinction between phase T2 and T3, because the transition of the reluctance \mathcal{R} and other parameters is considered instantaneous.

Opening transient drastically changes when the residual operating current is instantaneously supplied to the RCD. Fig. 8 shows the simulation of this situation. At $t = 0.01$ s a residual current of 50 mA at 400 Hz is applied. The magnetic flux is five times as large as the steady state values. These values are able to determine the tripping of the device. During the mechanical delay interval, magnetic flux follows its transient evolution. When the current is interrupted, the residual flux vanishes, according to the system's time constant. This study explains why RCDs operate with lower currents when they are instantaneously supplied, while slowly increasing residual

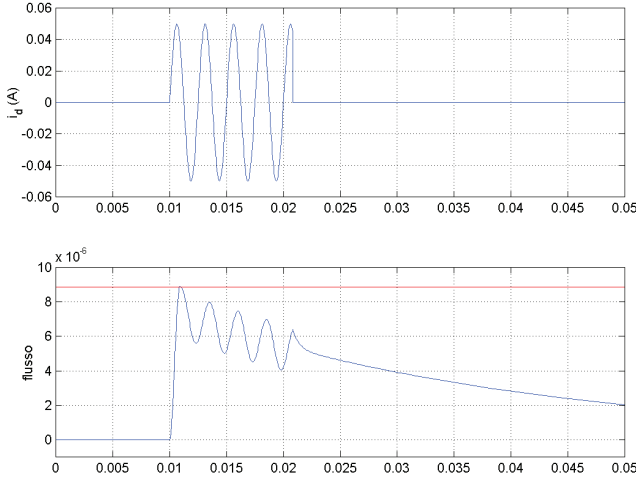

Fig. 8. Opening transient with instantaneous supply of residual current.

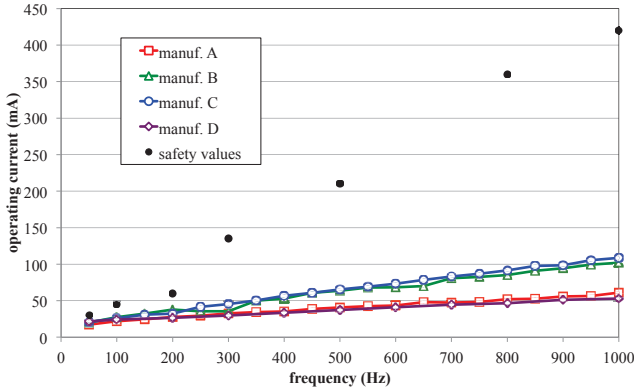

Fig. 9. RMS value of residual operating current of AC/d type RCDs.

currents causes RCD tripping only if they reach larger values than the rated one.

C. Residual operating current at high frequency

This test allows to determine the residual operating current at different frequencies for different classes of RCDs. Fig. 9 shows the behavior of AC/d type RCDs of different manufacturers. The first point at 50 Hz is used to verify the correct working of devices: according to IEC Standards 61008-1 and 61009-1 [20], [21] the value must be between $I_{\Delta n}/2$ and $I_{\Delta n}$. All tested devices show the same qualitative behavior: the higher the frequency, the larger the operating current. The increasing trend with frequency is mainly due to the fact that at higher frequency, higher magnetic force is required to activate the release mechanism because the force acts to the floating anchor for a shorter time. Contributory causes are larger losses due to eddy currents and hysteresis at high frequency. The different slope is mainly due to the constructive model of the relay, in particular the position of the permanent magnet. in the magnetic circuit. The measured tripping currents are compared with the so called *safety values*,

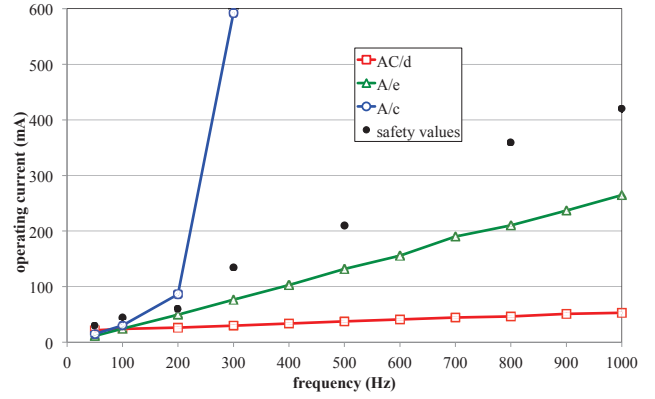

Fig. 10. Comparison of measured residual operating current between different types of RCD.

obtained by rescaling the asymptotic safety value of 30 mA by the frequency factor F_f . The comparison shows that all devices maintain their protective function in the whole range of frequencies under study. Different conclusions can be drawn when comparing the measurements of operating current for different types of RCDs. In Fig. 10 data of AC/d, A/e and A/c types assembled by manufacturer D, are presented. The AC/d type is the same already discussed in Fig. 9. The operating currents for A/e type RCDs are larger than those of the AC/d type, but they still satisfy the safety constraints. Considering the curve for A/c type RCD, due to a specific tuning of capacitors with respect to the fundamental frequency, the operating current increases exponentially. This behavior is common to all devices equipped with capacitors, because at high frequency the relay is short-circuited by the capacitor connected in parallel. At 200 Hz the protective function is already lost.

The accuracy of the model developed in Section II is also verified when predicting the operating current of AC/d type of manufacturer A. Model parameters are calibrated at 50 Hz and they are maintained constant for every frequency. The comparison between measurements and simulations is shown in Fig. 11. The good agreement is justified by a relative error is always lower than 8%. Larger errors arise at higher frequencies, where eddy currents and hysteresis losses become more evident.

D. Tripping time at high frequency

The compliance with the safety values is not a sufficient condition to guarantee the protection against indirect contacts. At each frequency the interruption time must be compatible with the current-time safety curve. IEC Standard 61009-1 [21] defines the tripping characteristic at 50/60 Hz. Again this values must be rescaled by the frequency factor F_f . The study of the opening transient in Section III-B showed that the tripping time when the residual current is instantaneously applied has two components: the time required by the magnetic flux to reach the tripping threshold and the time required to open the main circuit contacts. While the latter is almost constant and

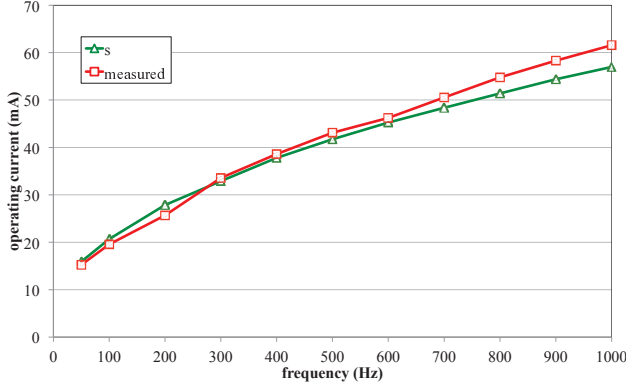

Fig. 11. Comparison between measured and simulated operating currents for AC/d type of manufacturer A.

TABLE II
TRIPPING TIME FOR A/C TYPE RCDs (S: SUCCESS, F: FAILURE).

f (Hz)	F_f (-)	< 300 ms		< 150 ms		< 40 ms	
		$F_f I_{\Delta n}$ (mA)	result (-)	$2F_f I_{\Delta n}$ mA	result -	$5F_f I_{\Delta n}$ mA	result -
50	1.0	30	s	60	s	150	s
100	1.5	45	s	90	s	225	s
200	2.0	60	f	120	s	300	s
300	4.5	135	f	270	f	675	s
400	5.8	173	f	345	f	863	f
500	7.0	210	f	420	f	1050	f
600	9.2	277	f	553	f	1383	f
700	10.8	324	f	649	f	1621	f
800	12.0	360	f	720	f	1800	f
900	13.0	390	f	780	f	1950	f
1000	14.0	420	f	840	f	2100	f

equal to the mechanical delay T3, the former depends on the residual current characteristics (e.g. initial value, waveform, ...). Thus, total tripping time is not a constant parameter of the RCD and its value is not a component characteristic. For this reason all devices have been tested five times; the test is considered passed if the break times was always lower than limits. Experiments show that AC/d and A/e type have break time by far lower than those of IEC Standards. We can conclude that if the tripping characteristic is satisfied at 50 Hz, all tested AC/d and A/e type RCDs maintain their protection function also at higher frequencies. A/c type RCDs have operating currents larger than those used for the experiments, thus they fail the test as reported in Table II.

E. Tripping in presence of third harmonic

High frequency residual currents are caused essentially by two effects:

- the phase-to-ground insulation impedance decreases at high frequencies, because the parasitic capacitive reactance decreases. Thus, at a fixed voltage, earth leakage currents are higher at high frequency, even if the insulation is not damaged;
- common mode filters of power electronic devices cause the presence of harmonic currents in the protective conductor.

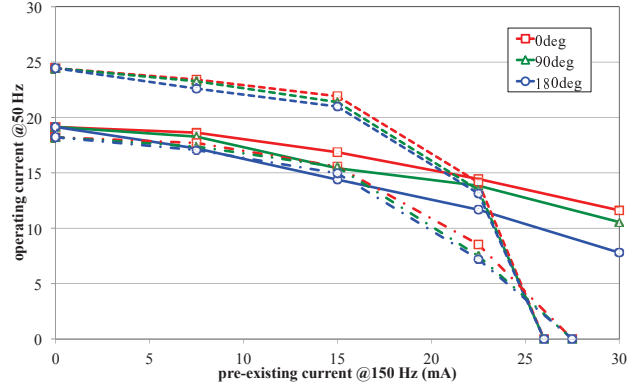

Fig. 12. Effect of phase shift on tripping time at 50 Hz with pre-existing current at 150 Hz for AC/d RCDs. solid line: manufacturer A, dotted line: manufacturer B, dash-dot line: manufacturer C.

It is necessary that these currents do not compromise the protective function of RCDs and they do not affect the continuity of supply because of unwanted tripping.

In this Section it is studied the value of operating current at 50 Hz when a pre-existing third harmonic residual current is present in the circuit. The choice of 150 Hz is due to the fact that it is the component that commonly gives higher contribution to harmonic distortion. The experiment is repeated with different rms values of current at 150 Hz and with different phase shifts with respect to the fundamental harmonic. Results of Fig. 12 show that the presence of a third harmonic residual current increases the sensitivity of the RCD causing the tripping with values lower than $I_{\Delta n}$. The effect is amplified by increasing the phase shift between fundamental and third harmonic.

The standard value of residual non-operating current is $0.5I_{\Delta n}$ [20]. The experiments show that this value is satisfied when the pre-existing current is also lower than $0.5I_{\Delta n}$. As good installation practice, high frequency residual currents should be limited to values below $I_{\Delta n}$ or, equivalently non-operating thresholds should be set taking into account the possible presence of high frequency residual currents.

F. Immunity to unwanted tripping

Unwanted tripping occurs when RCDs operate in non faulty circuits. The result is an interruption of continuity of supply which could be as dangerous as failures. In ordinary conditions, the RCD must not trip when for residual currents lower than $0.5I_{\Delta n}$. In order to test the immunity to unwanted tripping, in Fig. 13 is shown the high frequency current that causes the RCD tripping when superimposed to a 50 Hz residual current of $0.4I_{\Delta n}$. According to results discussed in Fig. 9, the larger the frequency the better the immunity. The experimentally evaluated high frequency non-operating current is:

$$I_{\Delta} = (0.45 + 0.55 \times 10^{-3} f) I_{\Delta n}. \quad (1)$$

This trend is reported as dashed line in Fig. 13.

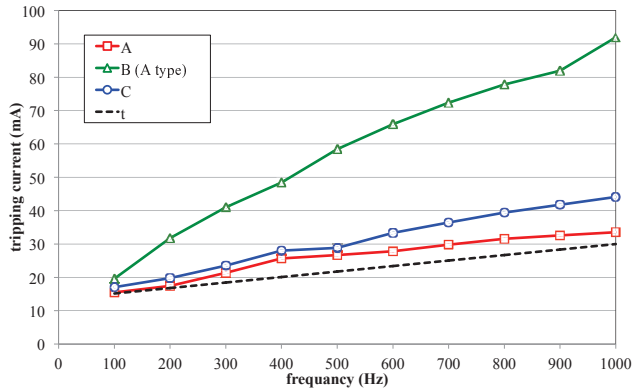

Fig. 13. Non-operating current at high frequency superimposed to $0.4I_{\Delta n}$ at 50 Hz.

IV. CONCLUSIONS

The aim of this work is two-fold:

- verify the satisfaction of the current-time safety curve at high frequency;
- experiment tripping and immunity to unwanted tripping in presence of harmonics;

The experiments carried out show that the behavior of RCDs at high frequency is strongly influenced by the typology rather than the values assumed by their physical parameters. AC/d and A/e type RCDs with direct coupling between differential transformer and relay have times and currents consistent with the safety values in the full frequency range. A/c types have restricted working frequency range, due to the specific tuning frequency between capacitors and relay inductance. The experimental cut-off frequency is about 200 Hz. Measurements at high frequency show that all AC/d and A/e type RCDs have tripping time below the values prescribed by the IEC Standards.

The presence of third harmonic in the residual current increases the RCD sensitivity: the larger the 150 Hz current, the lower the tripping current at 50 Hz. This effect is emphasized by increasing the phase shift between the third and the fundamental harmonic. A common problem among different typologies of RCD is the immunity to unwanted tripping: the harmonic distortion can cause the premature operation of devices. This effect can be mitigated only with a specific attention during the design phase of the installation. Finally experiments have not highlighted any blinding effect.

As far as the mathematical model is concerned, results obtained are in good agreement with measurements. The model parameters can be set by measurements at a single frequency, and maintained constant in the full range of operating frequencies. Even though the model has been only used to validate the results, it can be fruitfully adopted for the design of new devices. It is worth noting that the assessment of the model is limited to high sensitivity RCDs. Saturation effects in differential transformer and relay may become not negligible in other devices, where higher tripping currents are possible.

REFERENCES

- [1] T. Lee and T. Chan, "The effects of harmonics on the operational characteristics of residual-current circuit breakers," in *Proceedings of Energy Management and Power Delivery (EMPD '95)*, vol. 2, 21–23 Nov 1995, pp. 548–553.
- [2] E. Owen, "Power system grounding. II. RCD and GFCI," *IEEE Industry Application Magazine*, vol. 2, no. 4, pp. 71–73, Jul/Aug 1996.
- [3] M. Mitolo, "Shock hazard in the presence of protective residual-current devices," *IEEE Transactions on Industry Applications*, vol. 46, no. 4, pp. 1552–1557, Jul-Aug 2010.
- [4] MIL-STD-704F, *Aircraft Electrical Power Characteristics*, f ed., 2004.
- [5] S. Czapp, "The effect of PWM frequency on the effectiveness of protection against electric shock using residual current devices," in *International School of Nonsinusoidal Currents and Compensation (ISNCC)*, 15–18 Jun 2010, pp. 96–100.
- [6] H. Mazin, E. Nino, W. Xu, and J. Yong, "A study on the harmonic contributions of residential loads," *IEEE Transactions on Power Delivery*, vol. 26, no. 3, pp. 1592–1599, 2011.
- [7] J. Fuller, E. Fuchs, and D. Roesler, "Influence of harmonics on power distribution system protection," *IEEE Transactions on Power Delivery*, vol. 3, no. 2, 1988.
- [8] J. Brozek, "The effects of harmonics on overcurrent protection devices," in *Conference Record of the 1990 IEEE Industry Applications Society Annual Meeting*, vol. 2, 1990, pp. 1965–1967.
- [9] V. Wagner, J. Balda, D. Griffith, A. McEachern, T. Barnes, D. Hartmann, D. Phileggi, A. Emmanuel, W. Horton, W. Reid, R. Ferraro, and W. Jewell, "Effects of harmonics on equipment," *IEEE Transactions on Power Delivery*, vol. 8, no. 2, pp. 672–680, Apr 1993.
- [10] W. Elmore, C. Kramer, and S. Zocholl, "Effect of waveform distortion on protective relays," *IEEE Transactions on Industry Applications*, vol. 29, no. 2, pp. 404–411, Mar/Apr 1993.
- [11] G. Biegelmeier, "Discrimination and nuisance tripping of residual current-operated devices in domestic and similar installations," in *Proceedings of Third International Conference on Installation Engineering Designing and Maintaining Successful Systems*, 7–8 Jun 1988, pp. 42–49.
- [12] P. Brennan, "Residual current device with high immunity to nuisance tripping," *IEE Proceedings G: Circuits, Devices and Systems*, vol. 140, no. 2, pp. 140–144, Apr 1993.
- [13] A. Featherstone and A. Sastrosubroto, "An examination of RCD performance during system disturbances (and other relays)," in *IEE Colloquium on Safeguarding Industrial Plant during Power System Disturbances*, 4 Dec 1989, pp. 3/1–3/6.
- [14] X. Luo, X. Wang, and M. Chen, "Tripping characteristics of residual current devices under nonsinusoidal currents," *IEEE Transactions on Industry Applications*, vol. 47, no. 3, pp. 1515–1521, May–Jun 2011.
- [15] Y. Xiang, V. Cuk, and J. Cobben, "Impact of residual harmonic current on operation of residual current devices," in *Proceedings of 10th International Conference on Environment and Electrical Engineering (EEEIC)*, 8–11 May 2011, pp. 1–4.
- [16] www.mathworks.com, Accessed March 15, 2012.
- [17] IEC/TR 60755, *General requirements for residual current operated protective devices*, 2nd ed., 2008.
- [18] IEC/TS 60479-1, *Effects of current on human beings and livestock - Part 1: General aspects*, 4th ed., 2007.
- [19] IEC/TS 60479-2, *Effects of current on human beings and livestock - Part 2: Special aspects*, 3rd ed., 2007.
- [20] IEC 61008-1, *Residual current operated circuit-breakers without integral overcurrent protection for household and similar uses (RCCBs) - Part 1: General rules*, 3rd ed., 2010.
- [21] IEC 61009-1, *Residual current operated circuit-breakers with integral overcurrent protection for household and similar uses (RCBOs) - Part 1: General rules*, 3rd ed., 2010.

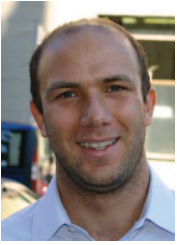

Fabio Freschi received the Laurea degree (summa cum laude) in Electrical Engineering at the Politecnico di Torino in 2002. From 2003 to 2005 he attended the Doctorate School in Electrical Engineering at the Electrical Engineering Department of the Politecnico di Torino. On April 2006 he obtained the PhD degree and the European Doctorate Degree in Electrical Engineering. From February to March 2005 and from September to October 2006 he was visiting researcher at Institut für Grundlagen und Theorie der Elektrotechnik, Technische Universität

Graz (Austria). From January 2005 to July 2007 he was research assistant at the Electrical Engineering Department of the Politecnico di Torino. He is

currently working as assistant professor in Fundamentals of Electrical Engineering at the Politecnico di Torino. His main research and scientific interests are related to numerical modelling and computation of electromagnetic and bioelectromagnetic fields. Part of his activity is related to the study and development of deterministic and stochastic optimization algorithms applied to the study of electromagnetic devices and complex energy systems. He is author of more than 90 conference and journal papers in these fields. He is member of the Cigré WG C4.25 "Issues related to ELF Electromagnetic Field exposure and transient contact currents". He is partner of several of national and international research projects and he acts as referee of many international journals in the field of optimization and operational research.