

Evaluation of various trough the thickness andcurvature approximations for free vibrationalanalysis of cylindrical and spherical shells.

*Original*

Evaluation of various trough the thickness andcurvature approximations for free vibrationalanalysis of cylindrical and spherical shells / Carrera, Erasmo; Campisi, Corrado; Cinefra, Maria; Soave, Marco. - In: INTERNATIONAL JOURNAL OF VEHICLE NOISE AND VIBRATION. - ISSN 1479-1471. - 7:1(2011), pp. 16-36.

*Availability:*

This version is available at: 11583/2372595 since:

*Publisher:*

Inderscience

*Published*

DOI:

*Terms of use:*

This article is made available under terms and conditions as specified in the corresponding bibliographic description in the repository

*Publisher copyright*

(Article begins on next page)

---

# Evaluation of various trough the thickness and curvature approximations for free vibrational analysis of cylindrical and spherical Shells

---

## E. Carrera

Department of Aeronautics and Space Engineering,  
Politecnico di Torino, Turin, Italy  
e-mails: erasmo.carrera@polito.it

## C. Campisi

Department of Aeronautics and Space Engineering,  
Politecnico di Torino, Turin, Italy  
e-mails: corrado.campisi@polito.it

## M. Cinefra

Department of Aeronautics and Space Engineering,  
Politecnico di Torino, Turin, Italy  
e-mails: maria.cinefra@polito.it

## M. Soave

Department of Aeronautics and Space Engineering,  
Politecnico di Torino, Turin, Italy  
e-mails: marco.soave@live.it

**Abstract:** Cylindrical and Spherical Shells are largely used in several engineering fields, especially in aerospace vehicles as structural elements and in automotive vehicles as shafts or exhaust and induction systems. Due to their particular relations with vibrations of automotive structures, this work compares various, significant shell theories to evaluate the free vibration response of cylindrical and spherical shells made of homogeneous, isotropic materials. Thin shell theories and shear deformation shell theories are compared with refined theories with linear, parabolic, third-order and fourth-order displacement fields for both in-plane and out-of-plane displacement components (including transverse normal strain effects). As far as approximation of the curvature terms is concerned, Donnell (shallow shell), Love and exact Flügge theories are been considered. As a result a quite comprehensive analysis has been conducted for the case of simply supported shells with constant radii of curvature and rectangular projection on the reference surface plane; closed-form Navier-type solutions are obtained for these particular cases. Fundamental and higher frequency parameters are compared by varying the various geometrical parameters of the considered cylindrical and spherical shells (thickness  $h$ , length  $a, b$  and radii  $R_\alpha, R_\beta$ ). Approximations related to the considered shell theories are dealt with in detail. Conclusions are drawn on the use of the most appropriate shell theories for a given shell geometry.

**Keywords:** Cylindrical and Spherical Shells, Free Vibration, Refined Theories, Love and Donnell Theories.

---

## 1 Introduction

Thin plate and shell panels are extensively used to build significant structural part of aerospace, automotive, ship vehicles, shell-made civil constructions and in automotive vehicles as shafts or exhaust and induction systems. The development of appropriate shell theories

is a well established topic of structural analysts of these structures. The analysis of their vibration characteristics is a fundamental topic at the early design stage of shell structures. Most of shell classical theories were originally developed for thin elastic isotropic shells, and are based on the Kirchoff-Love assumptions (or LFAT-Love First Approximation Theories):

- Thin shells
- Small shell deflections
- Normal stresses which are perpendicular to the middle surface can be neglected in comparison with other stresses;
- Straight lines which are normal to the undeformed middle surface remain straight and normal to the deformed middle surface.

No precise definition of thinness is available, but LFAT are expected to yield sufficiently accurate results when the ratio of the thickness to the radius of curvature of the reference surface can be neglected with respect to unity. This particular approximation is known as *Love's approximation*. The assumption that the deflections of the shell are small permits one to refer all the derivations and calculation to the original configuration of the shell, and ensures that the resulting theory will be a linear theory. It is expected that the third assumption will generally be valid except in the vicinity of highly concentrated loads. The fourth assumption implies that all of the transverse shear strain components in the direction of the normal to the reference surface vanish. The TPT (Thin Plate Theory) and TST (Thin Shell Theory) are based on this assumption.

A second class of thin elastic, isotropic moderately thick shell theories, which we shall denote as LSAT (Love Second Approximation Theories), has also been developed. All the shell theories, in which one or more of Kirchoff-Love's original postulates are suspended, are assigned to this group.

An elastic shell theory in which the thinness assumption is delayed has independently been derived by Flügge (1), Lur'e (2) and Byrne (3). The effects of transverse shear deformations (SDT-Shear Deformation Theory) and normal stresses have been considered by Hildebrand, Reissner and Thomas (4) while non-linear theories were considered by Sanders (5). Moreover, other approximations on curvature terms for shallow shell analysis have been introduced by Donnell (6) and Mushtari (7). A large variety of applications of both LFAT and LSAT approximations, have been presented in the literature.

A survey of most of the known contributions to LFAT and LSAT can be found in the work of Naghdi (8), in the excellent monograph by Leissa (9), (10) and in the more recent review papers (11), (12) and book by Qatu (13).

Loy, Lam and Reddy in (14) have conducted a vibration analysis of isotropic and functionally graded shells composed of steel and nickel; the analysis was carried out with strain-displacement relations according to Love's shell theory. Matsunaga has published a large variety of papers about vibration analysis of isotropic and FG plates and shells. In (15), a two-dimensional higher-order shell theory was applied to the free vibration problems of a simply supported

cylindrical shell subjected to axial stresses. The effects of higher-order deformations such as shear deformations with thickness changes and rotatory inertia on natural frequencies of thick elastic circular cylindrical shells are studied. In (16), the previous method was applied to cross-ply laminated composite circular cylindrical shells, where the present global higher-order approximate theories were able to accurately predict the natural frequencies and buckling stresses of the examined shells. More recently in (17) a two-dimensional(2D)higher-order deformation theory has been presented for vibration and buckling problems of circular cylindrical shells made of functionally graded materials. In order to evaluate the method based on the power series expansion of continuous displacement components in this and in the other works, the author has conducted a vibration analysis of isotropic shells. These results are compared with the present solution in section 4. A further approach for free vibration analysis of thin circular cylindrical shell has been presented in (18) by Xuebin where a method for calculating the free-vibration frequencies of thin circular cylindrical shells, based on Flügge's shell theory equations for orthotropic materials, is given. Numerical examples are given for isotropic and orthotropic shells.

A new impulse to the development of refined shell theories has been given by the advent of composite materials in the late 60'. These materials exhibit high transverse shear deformation and discontinuous material properties in the thickness direction. Both of these features require the developments or refined theories, (19), (20). A good survey of the theories adopted in the dynamic analysis of composite laminated shells has been presented by Soldatos (21). In this survey governing equations and numerical results are quoted for Donnell's, Love's, Sanders' and Flügge's theories based on CLT approximations, and for Donnell's, Love's and Sanders' theories based on SDT approximations. In depth investigations of TST and SDT assumptions and of Donnell, Love and Flügge theories (the latter refers to approximations on curvature) has been given in (22). Further free vibration analysis of composite cylindrical shells have been considered by Yadav and Verma in (23), while Liew et al. have presented a three-dimensional vibration analysis for spherical shells subjected to different boundary conditions in (24). To the best of the authors' knowledge, no results are known in which the approximation related to refined models, including transverse normal strain effects, are compared, in a systematic sense, with those introduced by curvature (Love, Donnell) for both cylindrical and spherical shells. Over the last decade the authors have developed a unified formulation (UF) (25), (26) in which the order of expansion of the displacement field along the thickness of the shell is taken as a free parameter of the problem. As a result, an exhaustive variable kinematic model has been obtained. Poisson thickness locking phenomenon in the bending was considered (27).

The present paper is restricted to shells made of homogeneous and isotropic materials. Refined theories

with up to fourth-order displacement fields, for both in-plane and transverse displacements, are compared to evaluate the free vibration response of cylindrical and spherical shells. The Unified Formulation is employed to derive shell equations which are solved for the case of simply supported boundary conditions and doubly curved shells with constant curvatures. Navier type closed form solutions are obtained. Love's and Donnell's approximations are compared in the framework of 1-4 higher order theories and classical ones.

The article has been organized as follows: the geometry of the shells is given in Section 2 ; the used shell theories and approximations are given in 3.1 and 3.2, respectively; Carrera Unified Formulations and closed-form solutions for the free-vibration problem of the governing equations are described in 3.3 and 3.4 respectively; the numerical discussion is conducted in 4; the conclusions are then summarized. Appendix shows the explicit form of the governing differential equations.

## 2 Geometry

Shells are bi-dimensional structures with one dimension, in general the thickness in  $z$  direction, negligible with respect to the others two in the plane directions. Shells present radii of curvature  $R_\alpha$  and  $R_\beta$  along the two in-plane directions  $\alpha$  and  $\beta$  respectively. Length along  $\alpha$  coordinate is called  $a$  while the length along  $\beta$  coordinate is called  $b$ . Curvilinear reference system  $(\alpha, \beta, z)$  for shells is indicated in Fig. 1. The reference surface is a curved surface, and thus will be curvilinear the coordinates  $\alpha$  and  $\beta$  with reference to middle surface  $\Omega$ . The third coordinate is perpendicular called  $z$ . The following well know shell differential relations are given (13):

$$\begin{aligned} ds^2 &= H_\alpha d\alpha^2 + H_\beta d\beta^2 + H_z dz^2 \\ d\Omega &= H_\alpha H_\beta d\alpha d\beta \\ dV &= H_\alpha H_\beta H_z d\alpha d\beta dz \end{aligned} \quad (1)$$

where

$$\begin{aligned} H_\alpha &= A \left(1 + \frac{z}{R_\alpha}\right) \\ H_\beta &= B \left(1 + \frac{z}{R_\beta}\right) \\ H_z &= 1 \end{aligned} \quad (2)$$

$A$  e  $B$  are the coefficients of first fundamental form of reference surface and them, for shells to have constant curvature, have unit value. ( $A = B = 1$ ).

## 3 Considered Shell Theories

### 3.1 Classical and Refined shell theories

**Thin shell Theory** (TST), based on Cauchy, Poisson or Kirchhoff assumptions type (see (28), (29) and (30)),

discards transverse shear and through-the-thickness deformations. The displacement model related to CLT can be written in the following form:

$$\begin{aligned} u_\tau(\alpha, \beta, z) &= u_{0\tau}(\alpha, \beta) - z \frac{\partial u_{0z}(\alpha, \beta)}{\partial \tau}, \\ \text{with } \tau &= \alpha, \beta, z, \\ u_z(\alpha, \beta, z) &= u_{0z}(\alpha, \beta). \end{aligned} \quad (3)$$

It states that the section remains plane and orthogonal to the plate reference surface  $\Omega$ .  $u_0$  denotes the displacements value in correspondence to the reference surface  $\Omega$ . Transverse shear/normal stresses are discarded by TST.

Transverse shear deformations can be introduced according to Reissner and Mindlin's (see (31) and (32)) kinematic assumptions:

$$\begin{aligned} u_\tau(\alpha, \beta, z) &= u_{0\tau}(\alpha, \beta) + z u_{1\tau}(\alpha, \beta), \\ \text{with } \tau &= \alpha, \beta, z \\ u_z(\alpha, \beta, z) &= u_{0z}(\alpha, \beta). \end{aligned} \quad (4)$$

This theory is also denoted as **Shear Deformation Theory** (SDT). Transverse shear stresses show "a priori" constant piece-wise distribution.

SDT can be obtained from *ED1* theory considering a constant transverse displacement through the thickness. TST is obtained from SDT considering an infinite shear correction factor. In both TST and SDT, Poisson locking phenomena is contrasted by means of the plane-stress conditions as indicated in (33) and (27).

**Higher Order Theories** (HOTs) for displacement variables  $\mathbf{u}$  can be formulated according to the following expansion:

$$\begin{aligned} u_\tau(\alpha, \beta, z) &= u_{0\tau}(\alpha, \beta) + z^i u_{i\tau}(\alpha, \beta), \\ \text{with } \tau &= \alpha, \beta, z \\ \text{and } i &= 1, N. \end{aligned} \quad (5)$$

The summing convention for the repeated indexes has been adopted.  $N$  is the order of expansion, which is taken as a free parameter. In the numerical investigation  $N$  is considered to be as low as 1 and as high as 4. Higher order terms can be introduced in the kinematics assumptions in order to obtain refinements of Thin Shell Theory (TST) and Shear deformation Theory (SDT) models. According to the acronym system developed within Carrera Unified Formulation (CUF), the related theories are named as  $N1 - N4$  where the last number states the through-the-thickness expansion order. To notice that transverse normal strain effects are described by the above higher-order shell theories.

### 3.2 Love's and Donnell theories

A second class of shell theories have been introduced as far as approximations on curvature terms in the strain-displacement relations is concerned. Geometrical relations links strains  $\epsilon$  and displacements  $\mathbf{u}$ . Strains are conveniently grouped into in-plane and normal components denoted by the subscripts  $p$  and  $n$  respectively and the geometric relations are:

$$\boldsymbol{\epsilon}_p = \mathbf{D}_p \mathbf{u} + \mathbf{A}_p \mathbf{u} \quad (6)$$

$$\boldsymbol{\epsilon}_n = \mathbf{D}_{n\Omega} \mathbf{u} + \lambda_D \mathbf{A}_n \mathbf{u} + \mathbf{D}_{nz} \mathbf{u}$$

where

$$\mathbf{D}_p = \begin{bmatrix} \frac{\partial_\alpha}{H_\alpha} & 0 & 0 \\ 0 & \frac{\partial_\beta}{H_\beta} & 0 \\ \frac{\partial_\beta}{H_\beta} & \frac{\partial_\alpha}{H_\alpha} & 0 \end{bmatrix}; \mathbf{A}_p = \begin{bmatrix} 0 & 0 & \frac{1}{H_\alpha R_\alpha} \\ 0 & 0 & \frac{1}{H_\beta R_\beta} \\ 0 & 0 & 0 \end{bmatrix} \quad (7)$$

$$\mathbf{D}_{n\Omega} = \begin{bmatrix} 0 & 0 & \frac{\partial_\alpha}{H_\alpha} \\ 0 & 0 & \frac{\partial_\beta}{H_\beta} \\ 0 & 0 & 0 \end{bmatrix}; \mathbf{D}_{nz} = \begin{bmatrix} \frac{\partial}{\partial z} & 0 & 0 \\ 0 & \frac{\partial}{\partial z} & 0 \\ 0 & 0 & \frac{\partial}{\partial z} \end{bmatrix}; \quad (8)$$

$$\mathbf{A}_n = \begin{bmatrix} \frac{1}{-H_\alpha R_\alpha} & 0 & 0 \\ 0 & \frac{1}{-H_\beta R_\beta} & 0 \\ 0 & 0 & 0 \end{bmatrix}$$

$\lambda_D$  is a trace operator, it has been introduced to identify terms that are neglected in the *Donnell-type shallow shell theories*. It can be shown, (34) that by putting  $\lambda_D = 0$  the shell curvature are those of a the corresponding plate as it is in the Donnell type approximation theory. Donnell approximation are strongly related to the geometrical parameter  $a/R_\alpha$  and  $b/R_\beta$ .

Love shell theory is instead related to the following approximation for the coefficients of the second fundamental form Eq.2 of the shell:

$$H_\alpha = H_\beta = 1 \quad (9)$$

$$1/H_\alpha = 1/H_\beta = 1 \quad (10)$$

It appears evident that Love's approximations are related to the shell parameter  $h/R_\alpha$ ,  $h/R_\beta$ , where  $h$  is the shell thickness.

A shell theories that improve Love's approximations by introducing a truncated Taylor expansion of the Eq.(LoveII), is known as Flügge shell theories (34). In the present work we use an exact Flügge theory; that is terms  $H_\alpha$ ,  $H_\beta$  are fully retained in the governing shell equations.

### 3.3 Carrera Unified Formulation

Carrera Unified Formulation permits several two dimensional models to be obtained for shells, thanks to the separation of the unknown variables into a set of thickness functions only depending on the thickness coordinate  $z$ , and the correspondent unknowns depending on the in-plane coordinates  $(\alpha, \beta)$ . The

governing equations (see the Appendix) are written in terms of few *fundamental nuclei* which do not formally depend on the order of expansion  $N$  that is used in the  $z$ -direction and the variables description in the multilayered structure. The generic variable  $\mathbf{a}(\alpha, \beta, z)$  and its variation  $\delta\mathbf{a}(\alpha, \beta, z)$  can be written according to the following general expansion:

$$\begin{aligned} \mathbf{a}(\alpha, \beta, z) &= F_\tau(z) \mathbf{a}_\tau(\alpha, \beta) \\ \delta\mathbf{a}(\alpha, \beta, z) &= F_s(z) \delta\mathbf{a}_s(\alpha, \beta), \\ &\text{with } \tau, s = 1, \dots, N \end{aligned} \quad (11)$$

Bold letters denote arrays; the summing convention with repeated indexes  $\tau$  and  $s$  is assumed; and the order of expansion  $N$  goes from 1 to 4.

### 3.4 Closed Form Solution

For the derived boundary value problem, for particular geometry, material symmetry and boundary conditions, an analytical solution can be derived. For simply supported plates, a Navier-type closed-form solution may be found with the following harmonic assumptions for the field variables:

$$(u_{x_\tau}, \sigma_{xz_\tau}) = \sum_{m,n} (\hat{U}_{x_\tau}, \hat{S}_{xz_\tau}) \cos \frac{m\pi x}{a} \sin \frac{n\pi y}{b} e^{i\omega_{mn}t},$$

$$(u_{y_\tau}, \sigma_{yz_\tau}) = \sum_{m,n} (\hat{U}_{y_\tau}, \hat{S}_{yz_\tau}) \sin \frac{m\pi x}{a} \cos \frac{n\pi y}{b} e^{i\omega_{mn}t}, \quad (12)$$

$$(u_{z_\tau}, \sigma_{zz_\tau}) = \sum_{m,n} (\hat{U}_{z_\tau}, \hat{S}_{zz_\tau}) \sin \frac{m\pi x}{a} \sin \frac{n\pi y}{b} e^{i\omega_{mn}t}.$$

where  $a$  and  $b$  are the lengths of the plate along the two coordinates  $x$  and  $y$ .  $m$  and  $n$  represent the number of half-waves in  $x$  and  $y$  direction, respectively. These numbers characterize the vibration mode associated to the circular frequency  $\omega_{mn}$ .  $i = \sqrt{-1}$  is the imaginary unit and  $t$  the time. The quantities with  $\hat{\phantom{a}}$  indicate the amplitudes. These assumptions correspond to the simply-supported boundary conditions. Upon substitution of Eq.(12), the governing equations on  $\Omega$  assume the form of a linear system of algebraic equations in the domain, while the boundary conditions are exactly fulfilled.

Only the free-vibration analysis is addressed in this article. Therefore, the external mechanical loading is set to zero and the linear system of algebraic equations is:

$$\mathbf{K}^* \hat{\mathbf{U}} = \omega_{mn}^2 \mathbf{M} \hat{\mathbf{U}}, \quad (13)$$

where  $\mathbf{K}^*$  is the equivalent stiffness matrix obtained by means of static condensation (for further details see (35), (36)),  $\mathbf{M}$  is the inertial matrix and  $\hat{\mathbf{U}}$  is the vector of unknown variables. By defining  $\lambda_{mn} = \omega_{mn}^2$ , the solution of the associated eigenvalue problem becomes:

$$\|\mathbf{K}^* - \lambda_{mn} \hat{\mathbf{M}}\| = 0. \quad (14)$$

The eigenvectors  $\hat{\mathbf{U}}$  associated to the eigenvalues  $\lambda_{mn}$  (or to circular frequencies  $\omega_{mn}$ ) define the vibration modes

of the structure in terms of primary variables. Once the wave numbers  $(m,n)$  have been defined in the in-plane directions, the number of obtained frequencies becomes equal to the degrees of freedom of the employed two-dimensional model. It is possible to obtain the relative eigenvector, in terms of primary variables, for each value of frequency, in order to plot the modes in the thickness direction.

Explicit form of governing equations for double curved shells are given in Appendix.

## 4 Results

A vast numerical investigation on the free vibration of double curved shells has been conducted by varying the geometrical parameters, the vibration modes and the shell theories. Significant results have been obtained. The considered problems have been grouped according to the following list.

- **Case 1.** An assessment of the present solution with results from literature.
- **Case 2.** Cylindrical/spherical shell panels with variable thickness (see Figure 2).
- **Case 3.** A cylindrical shell panel with variable curvatures (see Figure 3).
- **Case 4.** Cylindrical shell panels with a variable in-plane aspect ratio (see Figure 4).

### *Case 1: assessment with available literature*

In order to validate the accuracy of the present theories a comparison with results provided by Loi (39), (14), Matsunaga (15), (16) and (17) is conducted. The first 10 frequencies are compared for a cylindrical shell panel. Reasonable agreement has been found with the results in (17), which consists of shell theories similar to the present one.

### *Case 2: analysis of thickness $h/R$ parameter*

Shells with a variable thickness parameter such as those in Figure 2, are considered. An effective comparison of the effect of shear deformation, higher order shear deformation, through-the-thickness strain and Love's approximation could be conveniently built for such a shell geometry. TST, SDT and  $N=1,2,3,4$  shell theories, related to the fundamental circular frequency parameter  $\bar{\omega}$  are compared in Table 2: where

$$\bar{\omega} = \omega \sqrt{\frac{R_\alpha^4 \rho}{E h^2}} \quad (15)$$

Five values of  $R_\alpha/h$  (2, 4, 10, 100, 1000) are analyzed. The frozen geometrical values are  $R_\alpha = 10$  and  $a = \frac{\pi}{3} R_\alpha = 10.46667$ . Two values of the number of waves along the circumferential  $\alpha$  direction  $m$  are considered,

while the number of radial waves is fixed to  $n = 0$ . The material data are Young modulus  $E = 73 \text{ GPa}$ , shear modulus  $G = 28.077 \text{ GPa}$ , density  $\rho = 2800 \text{ Kg/m}^3$  and Poisson ratio  $\nu = 0.34$ . Table 2 compares classical and advanced theories for  $m = 1, 10$  and  $n = 0$ . It has been confirmed that the error of thin shell theories, TST, increases as the thickness increases. Larger errors are obtained from an increase of the circumferential wave number. All the theories merge in the case of thin shells. Figure 6 clearly shows the inadequacy of TST theories for thick shell geometries. The effect of the number of circumferential waves,  $m$ , is investigated in Figure 7. Fourth-order theories and TST results are compared. The TST error increases both by  $m$  and  $R_\alpha/h$  increasing. Love type approximations are significantly subordinate to the thickness of the radius parameter  $h/R_\alpha$ . Table 3 compares Love's approximation results with the exact (Flügge type ones). TST, FSDT and fourth-order shell theories are considered for  $m=1$  and  $m=10$  waves number. Love's results merge to exact solutions for high  $h/R_\alpha$  values. It should be noticed that the errors due to curvature can be higher than those related to transverse shear deformation, as was shown in (22) for the laminate case. In other words, Table 3 shows that the inclusion of higher order effects in shell theories could be meaningless unless an accurate description of  $h/R_\alpha$  terms is made at the same time.

Spherical shell problems are considered in Table 4, the same conclusions as Table 2 and the analysis in Figure 6 can be made.

### *Case 3: analysis of curvature parameter $\gamma$*

The cylindrical shell problem in Figure 4 is considered. For a given panel (length and thickness) the curvature is considered as a parameter. Table 5 compares TST, FSDT and higher-order shell theories. The following data are considered:  $a = \alpha * R = 10.46667$ ,  $\frac{a}{h} = 4, 100$ ,  $h$  is 2.61 (for  $\frac{a}{h} = 4$ ) and  $h = 0.1046$  (for  $\frac{a}{h} = 100$ ). The case  $\gamma = 2\pi$  denotes a complete open cylindrical shell ( $m=1$  is possible in this case). The accuracy of various theories does not appear affected to any great extent by the  $\gamma$  parameter. The circular frequency parameter value merges in thin the shell case for  $a/h=100$ . This result is confirmed by Figures 8 and 9.

Donnell type approximations are compared in Table 6. These are independent from the  $a/h$  parameter, but significantly influenced by the curvature parameter  $\gamma$ . Errors related to Donnell approximations increases by  $\gamma$  increasing. Therefore the conclusions in the previous sections can be reconsidered in the following form: the conclusion of higher-order effects in shell theories can result meaningless unless an accurate description of the curvatures term related to  $\gamma$  is made at the same time.

### *Case 4: influence of in-plane aspect ratio*

The influence of in-plane aspect  $b/a$  of a cylindrical shell panel is considered in this section. The vibration of thin

and thick shells, related to six values of aspect ratio, are considered. The results are given in Tables 7 and 8 and Figures 10 and 11.

## 5 Conclusion

This work has evaluated various shell theories to analyze the free vibration response of cylindrical and spherical shells made of isotropic materials. Thin shells, shear deformation and higher-order theories are considered in the framework of Love and Donnell type approximations. A numerical investigation is presented to evaluate the approximations of various theories by varying the geometrical parameters (radius, thickness, aspect ratio) for lower and higher vibration modes. It has above all been concluded that inclusion of shear deformation and higher-order effects could result meaningless unless curvatures terms are correctly included in a given theories.

## References

- [1] W. Flügge. *Statik und Dynamik der Schalen*, Berlin: Springer-Verlag, 1934.
- [2] I. Lur'E. The general theory of thin shells. *Priklady Matematika y Mekanika*, **4**, 7, 1940.
- [3] R. Byrne. Theory of small deformations of thin shells. *University of Calgornia at Los Angeles Publications on Mathematics*, **2**, 103-152, 1944.
- [4] F.B. Hildebrand, E. Reissner and G.B. Thomas. Note on the foundations of the theory of small displacements of orthotropic shells. *NACA-TN-1833*, 1949.
- [5] L. Sanders. Nonlinear theories for thin shells. *Quarterly of Applied Mathematics* **21**, 21-36, 1963.
- [6] L.H. Donnell. Stability of thin-walled tubes under torsion. *NACA Report 479*, 1933.
- [7] K.M. Mushtari. On the stability of cylindrical shells subjected to torsion. *Trudy Karanskego aviatsionnugo inatituta*, 1938.
- [8] P.M. Naghdi. A survey of recent progress in the theory of elastic shells. *Applied Mechanics Reviews*, **9**, 365-368, 1956.
- [9] Leissa, A.W. Vibration of Plates. *NASA report*, NASA-SP-160, 1969.
- [10] Leissa, A.W. Vibration of Shells. *NASA report*, NASA-SP-288, 1973.
- [11] M.S. Qatu. Recent Research Advances in the Dynamic Behavior of Shells. Part 1 : Laminated Composite Shells. *Applied Mechanics Reviews*, **55(4)**, 325-350, 2002.
- [12] M.S. Qatu. Recent Research Advances in the Dynamic Behavior of Shells. Part 2: Homogeneous Shells. *Applied Mechanics Reviews*, **55(5)**, 415-434, 2002.
- [13] M.S. Qatu. Vibration of Laminated Shells and Plates. *Elsevier*, 406, 2004.
- [14] Loy C.T., Lam K.Y., Reddy J.N. Vibration of functionally graded cylindrical shells. *International Journal of Mechanical Science*, **41(3)**, 30924, 1999.
- [15] H. Matsunaga. Free vibration of thick circular cylindrical shells subjected to axial stresses. *Journal of Sound and Vibration*, **211(1)**, 117, 1998.
- [16] H. Matsunaga. Vibration and buckling of cross-ply laminated composite circular cylindrical shells according to a global higher-order theory. *International Journal of Mechanical Science*, **49(9)**, 106075, 2007.
- [17] H. Matsunaga. Free vibration and stability of functionally graded circular cylindrical shells according to a 2D higher-order deformation theory. *Composite Structure*, **88**, 519-531, 2009.
- [18] L. Xuebin. A new approach for free vibration analysis of thin circular cylindrical shell. *Journal of Sound and Vibrations*, **296**, 91-98, 2006.
- [19] Carrera, E. (2001), "Developments, ideas, and evaluations based upon Reissners Mixed Variational Theorem in the modeling of multilayered plates and shells", *Applied Mechanics Reviews*, **54**, 301-329.
- [20] E. Carrera. A historical review of zig-zag theories for multilayered plates and shells. *Applied Mechanics Reviews*, **56**, 287-308, 2003.

- [21] K.P. Soldatos. Influence of thickness shear deformation on free vibrations of rectangular plates, cylindrical panels and cylinders of antisymmetric angle-ply construction. *Journal of Sound and Vibration*, **119**, 111-137, 1987.
- [22] E. Carrera. The Effects of Shear Deformation and Curvature on Buckling and Vibrations of Cross-Ply Laminated Composite Shells. *Journal of Sound and Vibrations*, **150**(3), 405-433, 1991.
- [23] D. Yadav and N. Verma. Free vibration of composite circular cylindrical shells with random material properties. PartII: Applications. *Composite Structures*, **51**, 371-380, 2001.
- [24] K.M. Liew, L.X. Peng, T.Y. Ng. Three-dimensional vibration analysis of spherical shell panels subjected to different boundary conditions. *International Journal of Mechanical Sciences* **44**, 21032117, 2002.
- [25] E. Carrera. Evaluation of layer-wise mixed theories for laminated plates analysis. *AIAA Journal*, **26**, 830-839, 1998.
- [26] E. Carrera. Theories and finite elements for multilayered plates and shells: a unified compact formulation with numerical assessments and benchmarks. *Archives of Computational Methods in Engineering*, **10**, 215-296, 2003.
- [27] E. Carrea and S. Brischetto. Analysis of thickness locking in classical, refined and mixed theories for layered shells. *Composite Structures*. **85**, 83-90, 2008.
- [28] A.L. Cauchy. Sur l'équilibre et le mouvement d'une plaque solide. *Exercices de Mathématique*, **3**, 328-355, 1828.
- [29] S.D. Poisson. Memoire sur l'équilibre et le mouvement des corps elastique. *Memory Academic Science*, **8**, 357, 1829.
- [30] G. Kirchhoff. "Uber das Gleichgewicht und die Bewegung einer elastischen Scheibe". *Crelles Journal*, **40**, 51-88, 1850.
- [31] E. Reissner. The effect of transverse shear deformation on the bending of elastic plates. *Journal of Applied Mechanics*, **12**, 69-76, 1945.
- [32] R.D. Mindlin. Influence of rotatory inertia and shear in flexural motions of isotropic elastic plates. *Journal of Applied Mechanics*, **18**, 31-28, 1951.
- [33] S. Brischetto, E. Carrera. Analysis of thickness locking in classical, refined and mixed multilayered plate theories. *Composite Structures*. **82**, 549562, 2008.
- [34] H. Kraus. (1967), *Thin Elastic Shells*, John Wiley, New York.
- [35] E. Carrera. Layer-wise mixed models for accurate vibration analysis of multilayered plates. *Journal of Applied Mechanics*. **65**, 820-828, 1998.
- [36] E. Carrera. An assessment of mixed and classical theories on global and local response of multilayered, orthotropic plates. *Computers and Structures*. **50**, 183-198, 2000.
- [37] E. Carrera. A Study of Transverse Normal Stress Effect on Vibration of Multilayered Plates and Shells. *Journal of Sound and Vibrations*, 1999.
- [38] E. Carrera. Multilayered Shell Theories Accounting for Layerwise Mixed Description, Part 1: Governing Equations. *AIAA Journal*, **37**, 1107-1116, 1999.
- [39] C.T. Loy, K.Y. Lam and C. Shu. Analysis of cylindrical shells using generalized differential quadrature. *Shock Vibration*, **4**: 193198, 1997.



## A Governing Equations

The displacement approach is formulated in terms of  $\mathbf{u}$  by variationally imposing the equilibrium via the classical principle of virtual displacements. In the dynamic case this states that:

$$\begin{aligned} & \int_{\Omega} \int_A (\delta \epsilon_p^T \boldsymbol{\sigma}_p + \delta \epsilon_n^T \boldsymbol{\sigma}_n) d\Omega dz \\ &= \int_{\Omega} \int_A \rho \delta \mathbf{u} \ddot{\mathbf{u}} d\Omega dz + \delta L^e = \delta L^{in} + \delta L^e \end{aligned} \quad (16)$$

where subscripts  $p$  and  $n$  indicate in-plane and out-plane components, respectively;  $\epsilon$  and  $\sigma$  are the strain and stress vectors,  $\delta L^{in}$  is the virtual variation of inertial work,  $\delta L^e$  is the virtual variation of external work, and  $\Omega$  and  $A$  indicate respectively the reference plane of the shell and its thickness. Introducing the constitutive equations also known as Hooke law,

$$\boldsymbol{\sigma}_p = \mathbf{Q}_{pp} \boldsymbol{\epsilon}_p + \mathbf{Q}_{pn} \boldsymbol{\epsilon}_n, \quad (17)$$

$$\boldsymbol{\sigma}_n = \mathbf{Q}_{np} \boldsymbol{\epsilon}_p + \mathbf{Q}_{nn} \boldsymbol{\epsilon}_n. \quad (18)$$

where  $\mathbf{Q}_{pp}, \mathbf{Q}_{pn}, \mathbf{Q}_{np}, \mathbf{Q}_{nn}$  are [3x3] sub-arrays containing the elastic coefficients for an orthotropic layer in the structure reference system:

$$\mathbf{Q}_{pp} = \begin{bmatrix} Q_{11} & Q_{12} & Q_{16} \\ Q_{12} & Q_{22} & Q_{26} \\ Q_{16} & Q_{26} & Q_{66} \end{bmatrix}, \quad \mathbf{Q}_{pn} = \begin{bmatrix} 0 & 0 & Q_{13} \\ 0 & 0 & Q_{23} \\ 0 & 0 & Q_{36} \end{bmatrix}, \quad (19)$$

$$\mathbf{Q}_{np} = \begin{bmatrix} 0 & 0 & 0 \\ 0 & 0 & 0 \\ Q_{13} & Q_{23} & Q_{36} \end{bmatrix}, \quad \mathbf{Q}_{nn} = \begin{bmatrix} Q_{55} & Q_{45} & 0 \\ Q_{45} & Q_{44} & 0 \\ 0 & 0 & Q_{33} \end{bmatrix}. \quad (20)$$

and the geometrical relations given in Eq. 6 the equilibrium equations for classical displacement formulation state:

$$\begin{aligned} & \int_{\Omega} \int_A \delta \mathbf{u}_{\tau}^T \{ (-F_{\tau} \mathbf{D}_p^T + F_{\tau} \mathbf{A}_p^T) [\mathbf{Q}_{pp} (F_s \mathbf{D}_p + F_s \mathbf{A}_p) \\ & \quad + \mathbf{Q}_{pp} (F_s \mathbf{D}_{n\Omega} + F_s \mathbf{A}_n + F_{s_z})] \\ & \quad + (-F_{\tau} \mathbf{D}_{n\Omega}^T + F_{\tau} \mathbf{A}_n^T + F_{\tau_z}) [\mathbf{Q}_{np} (F_s \mathbf{D}_p + F_s \mathbf{A}_p) \\ & \quad + \mathbf{Q}_{nn} (F_s \mathbf{D}_{n\Omega} + F_s \mathbf{A}_n + F_{s_z})] \} \mathbf{u}_s d\Omega \\ & + \int_{\Gamma} \int_A \delta \mathbf{u}_{\tau}^T \{ F_{\tau} \mathbf{I}_p^T [\mathbf{Q}_{pp} (F_s \mathbf{D}_{n\Omega} + F_s \mathbf{A}_n + F_{s_z})] \\ & \quad + F_{\tau} \mathbf{I}_{n\Omega}^T [\mathbf{Q}_{np} (F_s \mathbf{D}_p + F_s \mathbf{A}_p) \\ & \quad + \mathbf{Q}_{nn} (F_s \mathbf{D}_{n\Omega} + F_s \mathbf{A}_n + F_{s_z})] \} \mathbf{u}_s d\Gamma \\ & = \int_{\Omega} \delta \mathbf{u}_{\tau}^T \mathbf{p}_{\tau} d\Omega^p + \int_{\Omega} \delta \mathbf{u}_{\tau}^T \rho F_{\tau} F_s \ddot{\mathbf{u}}. \end{aligned} \quad (21)$$

where  $\mathbf{I}_p$  and  $\mathbf{I}_{n\Omega}$  are identity matrices to perform the integration by parts.

$$\mathbf{I}_p = \begin{bmatrix} \frac{1}{H_{\alpha}} & 0 & 0 \\ 0 & \frac{1}{H_{\beta}} & 0 \\ \frac{1}{H_{\beta}} & \frac{1}{H_{\alpha}} & 0 \end{bmatrix}, \quad \mathbf{I}_{n\Omega} = \begin{bmatrix} 0 & 0 & \frac{1}{H_{\alpha}} \\ 0 & 0 & \frac{1}{H_{\beta}} \\ 0 & 0 & 0 \end{bmatrix}. \quad (22)$$

The differential system of governing equations and the related boundary conditions are as follows:

$$\begin{aligned} \delta \mathbf{u}_{\tau} : & & \mathbf{K}_d^{\tau s} \mathbf{u}_s &= \mathbf{M}^{\tau s} \ddot{\mathbf{u}}_s + \mathbf{p}_{\tau} \\ \text{geometrical on } \Gamma^g & & \text{mechanical on } \Gamma^m & \\ \mathbf{u}_s = \bar{\mathbf{u}}_s & \text{ or } & \mathbf{\Pi}_d^{\tau s} \mathbf{u}_s &= \mathbf{\Pi}_d^{\tau s} \bar{\mathbf{u}}_s \end{aligned} \quad (23)$$

in which the bar denotes assigned. The introduced differential arrays are given by the following relations:

$$\begin{aligned} \mathbf{K}_d^{\tau s} &= \int_A (-F_{\tau} \mathbf{D}_p^T + F_{\tau} \mathbf{A}_p^T) [\mathbf{Q}_{pp} (F_s \mathbf{D}_p + F_s \mathbf{A}_p) \\ & \quad + \mathbf{Q}_{pp} (F_s \mathbf{D}_{n\Omega} + F_s \mathbf{A}_n + F_{s_z})] \\ & \quad + (-F_{\tau} \mathbf{D}_{n\Omega}^T + F_{\tau} \mathbf{A}_n^T + F_{\tau_z}) [\mathbf{Q}_{np} (F_s \mathbf{D}_p + F_s \mathbf{A}_p) \\ & \quad + \mathbf{Q}_{nn} (F_s \mathbf{D}_{n\Omega} + F_s \mathbf{A}_n + F_{s_z})] H_{\alpha} H_{\beta} dz. \end{aligned} \quad (24)$$

$$\begin{aligned} \mathbf{\Pi}_d^{\tau s} &= \int_A \{ F_{\tau} \mathbf{I}_p^T [\mathbf{Q}_{pp} (F_s \mathbf{D}_{n\Omega} + F_s \mathbf{A}_n + F_{s_z})] \\ & \quad + F_{\tau} \mathbf{I}_{n\Omega}^T [\mathbf{Q}_{np} (F_s \mathbf{D}_p + F_s \mathbf{A}_p) \\ & \quad + \mathbf{Q}_{nn} (F_s \mathbf{D}_{n\Omega} + F_s \mathbf{A}_n + F_{s_z})] \} H_{\alpha} H_{\beta} dz. \end{aligned} \quad (25)$$

$$\mathbf{M}^{\tau s} = \int_A \rho F_{\tau} F_s \mathbf{I} H_{\alpha} H_{\beta} dz \quad (26)$$

where  $\mathbf{I}$  is the unit array. The differential operators given in Eq. 24 and 25 could be written in terms of the following integrals which permit an a-priori integration in the thickness direction:

$$\begin{aligned} & (J^{\tau s}, J_{\alpha}^{\tau s}, J_{\beta}^{\tau s}, J_{\alpha/\beta}^{\tau s}, J_{\beta/\alpha}^{\tau s}, J_{\alpha\beta}^{\tau s}) \\ &= \int_A F_{\tau} F_s (1, H_{\alpha}, H_{\beta}, \frac{H_{\alpha}}{H_{\beta}}, \frac{H_{\beta}}{H_{\alpha}}, H_{\alpha} H_{\beta}) dz \\ & \quad (J^{\tau_z s}, J_{\alpha}^{\tau_z s}, J_{\beta}^{\tau_z s}, J_{\alpha\beta}^{\tau_z s}); \\ &= \int_A F_{\tau_z} F_s (1, H_{\alpha}, H_{\beta}, H_{\alpha} H_{\beta}) dz \\ & \quad (J^{\tau_s z}, J_{\alpha}^{\tau_s z}, J_{\beta}^{\tau_s z}, J_{\alpha\beta}^{\tau_s z}) \\ &= \int_A F_{\tau} F_{s_z} (1, H_{\alpha}, H_{\beta}, H_{\alpha} H_{\beta}) dz \\ & \quad (J^{\tau_z s_z}, J_{\alpha\beta}^{\tau_z s_z}) = \int_A F_{\tau_z} F_{s_z} (1, H_{\alpha}, H_{\beta}) dz \end{aligned} \quad (27)$$

By using the integrals defined in Eqns.(27) the elements of the differential operators in the  $3 \times 3$  arrays of Eqns.(24) can be explicitly written taking into account that the double subscript is written accordingly with the

new position of elastic coefficients in Eq. 19. First the stiffness array  $K^{\tau s}$  is written,

$$\begin{aligned}
K_{d_{11}}^{\tau s} &= Q_{nn_{11}} J_{\alpha\beta}^{\tau z s z} + \frac{1}{R_\alpha} Q_{nn_{11}} (-J_{\beta}^{\tau z s} - J_{\beta}^{\tau s z} + \frac{1}{R_\alpha} J_{\beta\alpha}^{\tau s}) \\
&- Q_{pp_{11}} J_{\frac{\beta}{\alpha}}^{\tau s} \partial_{\alpha\alpha} - 2Q_{pp_{13}} J^{\tau s} \partial_{\alpha\beta} - Q_{pp_{33}} J_{\frac{\alpha}{\beta}}^{\tau s} \partial_{\beta\beta} \\
K_{d_{12}}^{\tau s} &= Q_{nn_{12}} J_{\alpha\beta}^{\tau z s z} + Q_{nn_{12}} (-\frac{1}{R_\beta} J_{\alpha}^{\tau z s} - \frac{1}{R_\alpha} J_{\beta}^{\tau s z} \\
&+ \frac{1}{R_\alpha R_\beta} J^{\tau s}) - Q_{pp_{12}} J^{\tau s} \partial_{\alpha\beta} - Q_{pp_{13}} J_{\frac{\beta}{\alpha}}^{\tau s} \partial_{\alpha\alpha} \\
&- Q_{pp_{32}} J_{\frac{\alpha}{\beta}}^{\tau s} \partial_{\beta\beta} + Q_{pp_{33}} J_{\alpha\beta}^{\tau s} \\
K_{d_{13}}^{\tau s} &= Q_{nn_{11}} (J_{\beta}^{\tau z s} \partial_{\alpha} - \frac{1}{R_\alpha} J_{\frac{\beta}{\alpha}}^{\tau s} \partial_{\alpha}) + Q_{nn_{12}} (J_{\alpha}^{\tau z s} \partial_{\beta} \\
&- 1 \frac{1}{R_\alpha} J^{\tau s} \partial_{\beta}) - Q_{pn_{13}} J_{\beta}^{\tau s z} \partial_{\alpha} - Q_{pn_{33}} J_{\alpha}^{\tau s z} \partial_{\beta} \\
&- \frac{1}{R_\alpha} (Q_{pp_{11}} J_{\frac{\beta}{\alpha}}^{\tau s} \partial_{\alpha} + Q_{pp_{31}} J^{\tau s} \partial_{\beta}) \\
&- \frac{1}{R_\beta} (Q_{pp_{12}} J^{\tau s} \partial_{\alpha} + Q_{pp_{32}} J_{\frac{\alpha}{\beta}}^{\tau s} \partial_{\beta}) \\
K_{d_{21}}^{\tau s} &= K_{d_{12}}^{\tau s} \\
K_{d_{22}}^{\tau s} &= Q_{nn_{22}} J_{\alpha\beta}^{\tau z s z} + \frac{1}{R_\beta} Q_{nn_{22}} (-J_{\alpha}^{\tau z s} - J_{\alpha}^{\tau s z} \\
&+ \frac{1}{R_\beta} J_{\alpha\beta}^{\tau s}) - Q_{pp_{22}} J_{\frac{\alpha}{\beta}}^{\tau s} \partial_{\beta\beta} - Q_{pp_{23}} J^{\tau s} (\partial_{\beta\alpha} + \partial_{\alpha\beta}) \\
&- Q_{pp_{33}} J_{\frac{\beta}{\alpha}}^{\tau s} \partial_{\beta\beta} K_{d_{23}}^{\tau s} = \tilde{C}_{nn_{22}} (J_{\alpha}^{\tau z s} \partial_{\beta} - \frac{1}{R_\beta} J^{\tau s} \partial_{\beta}) \\
&+ Q_{nn_{21}} (J_{\beta}^{\tau z s} \partial_{\alpha} - \frac{1}{R_\beta} J_{\frac{\alpha}{\beta}}^{\tau s} \partial_{\alpha}) - Q_{pn_{23}} J_{\alpha}^{\tau s z} \partial_{\beta} \\
&- Q_{pn_{33}} J_{\beta}^{\tau s z} \partial_{\alpha} - \frac{1}{R_\beta} Q_{pp_{22}} J_{\frac{\alpha}{\beta}}^{\tau s} \partial_{\beta} - \frac{1}{R_\beta} Q_{pp_{32}} J^{\tau s} \partial_{\alpha} \\
&- \frac{1}{R_\alpha} Q_{pp_{21}} J^{\tau s} \partial_{\beta} - \frac{1}{R_\alpha} Q_{pp_{31}} J_{\frac{\beta}{\alpha}}^{\tau s} \partial_{\alpha} \\
K_{d_{31}}^{\tau s} &= -K_{d_{13}}^{\tau s} \\
K_{d_{32}}^{\tau s} &= -K_{d_{23}}^{\tau s} \\
K_{d_{33}}^{\tau s} &= -Q_{nn_{11}} J_{\frac{\beta}{\alpha}}^{\tau s} \partial_{\alpha\alpha} - 2Q_{nn_{12}} J^{\tau s} \partial_{\alpha\beta} \\
&- Q_{nn_{22}} J_{\frac{\alpha}{\beta}}^{\tau s} \partial_{\beta\beta} + Q_{nn_{33}} J_{\alpha\beta}^{\tau z s z} + \frac{1}{R_\alpha} (\frac{1}{R_\alpha} Q_{pp_{11}} J_{\frac{\beta}{\alpha}}^{\tau s} \\
&+ Q_{pp_{31}} J_{\beta}^{\tau z s} + Q_{pp_{13}} J_{\beta}^{\tau s z}) + \frac{2}{R_\alpha R_\beta} J_{\alpha}^{\tau s} Q_{pp_{12}} \\
&+ \frac{1}{R_\beta} (\frac{1}{R_\beta} Q_{pp_{22}} J_{\frac{\alpha}{\beta}}^{\tau s} + Q_{pp_{32}} J_{\alpha}^{\tau z s} + Q_{pp_{23}} J_{\alpha}^{\tau s z})
\end{aligned}$$

The boundary array  $\Pi^{\tau s}$  leads to,

$$\begin{aligned}
\Pi_{d_{11}}^{\tau s} &= Q_{pp_{11}} J_{\frac{\beta}{\alpha}}^{\tau s} \partial_{\alpha} + Q_{pp_{13}} J^{\tau s} (\partial_{\alpha} + \partial_{\beta}) + Q_{pp_{33}} J_{\frac{\alpha}{\beta}}^{\tau s} \partial_{\beta} \\
\Pi_{d_{12}}^{\tau s} &= Q_{pp_{13}} J_{\frac{\beta}{\alpha}}^{\tau s} \partial_{\alpha} + Q_{pp_{33}} J^{\tau s} \partial_{\alpha} + Q_{pp_{12}} J^{\tau s} \partial_{\beta} + \\
&Q_{pp_{32}} J_{\frac{\alpha}{\beta}}^{\tau s} \partial_{\beta} \\
\Pi_{d_{13}}^{\tau s} &= Q_{pp_{13}} J_{\beta}^{\tau s z} + Q_{pp_{33}} J_{\alpha}^{\tau s z} + \frac{1}{R_\alpha} (Q_{pp_{11}} J_{\frac{\beta}{\alpha}}^{\tau s} \\
&+ Q_{pp_{31}} J^{\tau s}) + \frac{1}{R_\beta} (Q_{pp_{32}} J_{\frac{\alpha}{\beta}}^{\tau s} + Q_{pp_{12}} J^{\tau s}) \\
\Pi_{d_{21}}^{\tau s} &= Q_{pp_{31}} J_{\frac{\beta}{\alpha}}^{\tau s} \partial_{\alpha} + Q_{pp_{21}} J^{\tau s} \partial_{\alpha} + Q_{pp_{33}} J^{\tau s} \partial_{\beta} \\
&+ Q_{pp_{23}} J_{\frac{\alpha}{\beta}}^{\tau s} \partial_{\beta} \\
\Pi_{d_{22}}^{\tau s} &= Q_{pp_{33}} J_{\frac{\beta}{\alpha}}^{\tau s} \partial_{\alpha} + Q_{pp_{23}} J^{\tau s} (\partial_{\alpha} + \partial_{\beta}) + Q_{pp_{22}} J_{\frac{\alpha}{\beta}}^{\tau s} \partial_{\beta} \quad (29) \\
\Pi_{d_{23}}^{\tau s} &= Q_{pp_{33}} J_{\beta}^{\tau s z} + Q_{pp_{23}} J_{\alpha}^{\tau s z} + \frac{1}{R_\alpha} (Q_{pp_{31}} J_{\frac{\beta}{\alpha}}^{\tau s} \\
&+ Q_{pp_{21}} J^{\tau s}) + \frac{1}{R_\beta} (Q_{pp_{22}} J_{\frac{\alpha}{\beta}}^{\tau s} + Q_{pp_{32}} J^{\tau s}) \\
\Pi_{d_{31}}^{\tau s} &= Q_{nn_{11}} J_{\beta}^{\tau s z} - \frac{1}{R_\alpha} (Q_{nn_{11}} J_{\frac{\beta}{\alpha}}^{\tau s} \\
&+ Q_{nn_{21}} J^{\tau s}) + Q_{nn_{21}} J_{\alpha}^{\tau s z} \\
\Pi_{d_{32}}^{\tau s} &= Q_{nn_{12}} J_{\beta}^{\tau s z} - \frac{1}{R_\beta} (Q_{nn_{22}} J_{\frac{\alpha}{\beta}}^{\tau s} + Q_{nn_{12}} J^{\tau s}) \\
&+ Q_{nn_{22}} J_{\alpha}^{\tau s z} \\
\Pi_{d_{33}}^{\tau s} &= Q_{pp_{11}} J_{\frac{\beta}{\alpha}}^{\tau s} \partial_{\alpha} + Q_{nn_{12}} J^{\tau s} (\partial_{\alpha} + \partial_{\beta}) + Q_{nn_{22}} J_{\frac{\alpha}{\beta}}^{\tau s} \partial_{\beta}
\end{aligned}$$

One can see the previous author's works (37),(38) for further details.

### **Bio- sketch of Erasmo CARRERA**

After earning two degrees (Aeronautics, 1986 and Aerospace Engineering, 1988) in the Politecnico di Torino, Carrera received his PhD in Aerospace Engineering in 1991. He began working as a Researcher at the Department of Aeronautics and Space Engineering of Politecnico di Torino in 1992 holding courses on Missiles and Aerospace Structural Design, Plates and Shells, FEM and since 2000 he is associate Professor. He visited Universitaet Stuttgart, Virginia Tech, SUPMECA, Paris and CRP H Tudor. His main research topics are: composite materials, FEM, beams, plates and shells, postbuckling and stability, smart structures, thermal stress, aeroelasticity, multibody dynamics, non classical lifting systems and Multifield Problem, inflatable structures for space applications and mechanics of carbon nano-tubes. On these topics dr Carrera has bring significant contributions. In particular he has proposed the Carrera Unified Formulations to developed hierarchical beam/plate/shell theories and Finite Elements for multilayered structures analysis as well as the generalization of classical and advanced variational methods for multifield problems. Carrera has been responsible of various research contracts with EU and international agencies/industries. In particular he Carrera has been responsible of the structural design and analysis of full-composite aircraft Sky-Y by Alenia Aeroanutica Torino, first EU full-composite aircraft. In 2008 E Carrera has been appointed has 'best associate professor of Politecnico di Torino'. Presently Carrera is deputy director of his Dep. He his an author of more than two hundred articles, many of which have been published in international journals. He has given plenary lectures in various Int Conferences. He serves as a referee for many journals and member of advisory board of Composite Structures for Mech of Adv Mat and Str. He has served the Ed. Board of many int. conferences.

### **Bio- sketch of Corrado CAMPISI**

After earning a degree (Physic, 2002) at the University of Eastern Piedmont (UPO) in Alessandria, Campisi received his PhD in Chemistry in 2008. He began working at the Department of Physic in UPO on i Econophysics field. During the PhD he studied control and power conditioning system for portable fuel cell generator and experimental design optimization of polymer electrolyte fuel cells with application for cogeneration photovoltaic/fuel cells. His main research topics are: mechanics of carbon nano-tubes, atomistic vs continuum approach.

### **Bio- sketch of Maria CINEFRA**

After earning two degrees in Aerospace Engineering (Bachelor's degree Marzo 2007 and Master degree

December 2008) at the Politecnico di Torino, Cinefra started her PhD in Aerospace Engineering at the same university in January 2009. The main aim of her research is the thermo-mechanical analysis of functionally graded plates and shells by using analytical and numerical tools, such as Finite Element Method (FEM). For this aim she collaborates with the Department of Mathematics of Universit di Pavia, the CRP H. Tudor of Luxembourg and the Department of Mechanics of Universit Paris X. She is co-author of various articles, some of which have been already published. These articles concern FGMs, analysis of piezoelectric structures, Carbon Nanotubes (CNT) and some numerical methods to overcome the locking phenomenon in FEs. In the current year, she has also experienced in teaching in the courses "structures for space vehicles" and "non-linear analysis of space structures

### **Bio- sketch of Marco SOAVE**

Marco Soave has got his degree in aerospace engineering at the Polytechnic of Turin in October 2008. He has worked as research at aerospace engineering department of the same Polytechnic where on the subject of classical and mixed for models analysis of plates and shells with FGM layers. He was granted by Regione Pieomonte t via STEP research program. Marco Soave is author af about 10 works some of these have been published in international journals.

**Table 1** CASE 1. Comparison of present analysis with available reference solution. Values of  $\omega R\sqrt{(1-\nu^2)\rho E}$  for data:  $n = 1, L/R = 20, h/R = 0.01$  and  $\nu = 0.3$ .

$m$	Present $N = 4$	Loi et al.(14)	Loi et al.(39)	Matsunaga(15)	Matsunaga(16)	Matsunaga(17)
1	0.016101	0.016101	0.016102	0.016102	0.016102	0.016014
2	0.009377	0.009382	0.009387	0.009383	0.009383	0.009369
3	0.022100	0.022105	0.022108	0.022103	0.022103	0.022094
4	0.042083	0.042095	0.042096	0.042084	0.042084	0.042078
5	0.067979	0.068008	0.068008	0.067979	0.067979	0.067972
6	0.099669	0.099730	0.099730	0.099667	0.099667	0.099660
7	0.137124	0.137239	0.137239	0.137121	0.137124	0.137113
8	0.180330	0.180527	0.180527	0.180326	0.180326	0.180315
9	0.229274	0.229594	0.229594	0.229268	0.229268	0.229255
10	0.283944	0.284435	0.284435	0.283937	0.283937	0.283921

**Table 2** CASE 2. Evaluation of thickness approximation through Classical Vs Refined theories comparison on  $\bar{\omega}$  of cylindrical shell. Thickness ratio  $a/h = 4$ .

$R_\alpha/h$	TST	SDT	$N=1$	$N=2$	$N=3$	$N=4$
$m = 1, n = 0$						
2	2.2574	1.7951	1.8537	1.8715	1.8286	1.8239
4	2.3087	2.1418	2.1672	2.1760	2.1542	2.1537
10	2.3261	2.2953	2.3004	2.3022	2.2977	2.2976
100	2.3296	2.3293	2.3293	2.3293	2.3293	2.3293
1000	2.3296	2.3296	2.3296	2.3296	2.3296	2.3296
$m = 10, n = 0$						
2	55.6653	33.4477	36.5433	32.5688	31.0479	29.6511
4	113.9186	64.5258	69.9936	68.6699	65.3820	64.1213
10	183.3306	138.7012	146.6983	146.8033	142.4050	141.7322
100	274.7840	271.1643	271.7578	271.7770	271.3685	271.3678
1000	275.7956	275.7580	275.7642	275.7645	275.7601	275.7601

**Table 3** CASE 2. CASE 2. Evaluation of Love effects in Classical Vs Refined theories comparison on  $\bar{\omega}$  of a cylindrical shell. Thickness ratio  $a/h = 4$ .

$R_\alpha/h$	TST		SDT		N=4	
	Exact	Love	Exact	Love	Exact	Love
$m = 1$						
2	2.2574	2.4072	1.7951	1.7366	1.8239	1.7450
4	2.3087	2.5621	2.1418	2.1398	2.1537	2.1233
10	2.3261	2.6112	2.2953	2.2047	2.2977	2.2929
100	2.3296	2.6207	2.3293	2.3645	2.3293	2.3292
1000	2.3296	2.6208	2.3296	2.3649	2.3296	2.3296
$m = 10$						
2	55.6653	36.6508	33.4477	33.0450	29.6511	34.7873
4	113.9186	73.3016	64.5258	64.2751	64.1213	66.5571
10	183.3306	183.2542	138.7012	138.5389	141.7322	141.5911
100	274.7840	275.0830	271.1643	271.1972	271.3678	271.3601
1000	275.7956	276.1023	275.7580	275.8000	275.7601	275.7600



**Table 6** CASE 3. Evaluation of Donnell effect in Classical Vs Refined theories comparison on  $\bar{\omega}$  of cylindrical shell.  
 $m = 1, n = 0$ .

$\gamma$	TST		SDT		N=4	
	Exact	Donnel	Exact	Donnel	Exact	Donnel
$a/h = 4$						
$\pi/12$	42.6023	42.8565	39.3885	39.6300	39.5628	39.7992
$\pi/10$	29.4623	29.7164	27.2375	27.4789	27.3596	27.5958
$\pi/9$	23.7965	24.0453	21.9982	22.2347	22.0976	22.3291
$\pi/8$	18.7412	18.9886	17.3236	17.5586	17.4029	17.6329
$\pi/6$	10.3519	10.6051	9.5657	9.8061	9.6115	9.8470
$\pi/5$	7.0687	7.3646	6.5298	6.8097	6.5624	6.8940
$\pi/4$	4.3826	4.6341	4.0462	4.2845	4.0678	4.3015
$\pi/3$	2.3010	2.5505	2.1220	2.3577	2.1347	2.3662
$\pi/2$	0.8263	1.0695	0.7600	0.9882	0.7654	0.9904
$2\pi$	0.1069	0.1945	0.1001	0.1945	0.0889	0.1945
$a/h = 100$						
$\pi/12$	43.8526	44.1589	43.8461	39.6300	43.8465	39.7992
$\pi/10$	30.1768	30.4813	30.1723	27.4789	30.1726	27.5958
$\pi/9$	24.4148	24.7136	24.4112	22.2347	24.4114	22.3291
$\pi/8$	19.2198	19.5165	19.2170	17.5586	19.2171	17.6329
$\pi/6$	10.5971	10.8997	10.5955	9.8061	10.7987	9.8470
$\pi/5$	7.2237	7.5246	7.2226	6.8097	7.2227	6.8940
$\pi/4$	4.4668	4.7644	4.4661	4.2845	4.4661	4.3015
$\pi/3$	2.3296	2.6207	2.3292	2.3577	2.3293	2.3662
$\pi/2$	0.8235	1.0979	0.8233	0.9882	0.8233	0.9904
$2\pi$	0.1029	0.0343	0.1029	0.1945	0.1029	0.1945

**Table 7** CASE 4. Evaluation of aspect ratio through Classical Vs Refined theories comparison on  $\bar{\omega}$  of thin cylindrical shell.  
 Data:  $m = n = 1, a/h = 100$ .

$b/a$	TST	SDT	N=1	N=2	N=3	N=4
$\gamma = \pi/12$						
1/4	463.3002	358.5981	380.2355	380.5826	368.9374	366.9058
1/2	250.9999	153.6208	159.1756	159.2953	155.8276	200.2818
3/4	114.5781	96.5716	99.0472	99.0963	97.4889	97.4384
2	53.0276	48.2679	48.9778	48.9939	48.5144	48.5071
5	44.2600	40.8129	41.3358	41.3580	41.0020	40.9973
10	43.0159	39.7446	40.2410	40.2648	39.9225	39.9211
$\gamma = 2\pi$						
1/4	0.7798	0.7401	0.7474	0.7444	0.7403	0.7403
1/2	0.3678	0.3643	0.3648	0.3674	0.3666	0.3663
3/4	0.2421	0.2392	0.2397	0.2429	0.2422	0.2417
2	0.1187	0.1120	0.1130	0.1116	0.1103	0.1094
5	0.1069	0.0981	0.1009	0.0932	0.0911	0.0901
10	0.1068	0.0999	0.1009	0.0920	0.0904	0.0931

**Table 8** CASE 4. As the previous table, thick cylindrical shell case  $a/h = 4$ .

$b/a$	$TST$	$SDT$	$N=1$	$N=2$	$N=3$	$N=4$
$\gamma = \pi/12$						
1/4	33.4341	33.3651	33.3766	33.3756	33.3677	33.3677
1/2	15.0837	15.0799	15.0805	15.0796	15.0792	15.0792
3/4	10.9270	10.9260	10.9262	10.9255	10.9254	10.9254
2	3.7522	3.7520	3.7520	3.7516	3.7516	3.7516
5	1.9106	1.9103	1.9104	1.9102	1.9102	1.9102
10	1.7724	1.7722	1.7722	1.7722	1.7721	1.7721
$\gamma = 2\pi$						
1/4	0.5628	0.5628	0.5628	0.5628	0.5628	0.5628
1/2	0.3287	0.3287	0.3287	0.3287	0.3287	0.3287
3/4	0.2087	0.2087	0.2087	0.2087	0.2087	0.2087
2	0.0538	0.0538	0.0538	0.0538	0.0538	0.0538
5	0.0114	0.0114	0.0114	0.0115	0.0115	0.0115
10	0.0049	0.0049	0.0049	0.0049	0.0049	0.0049

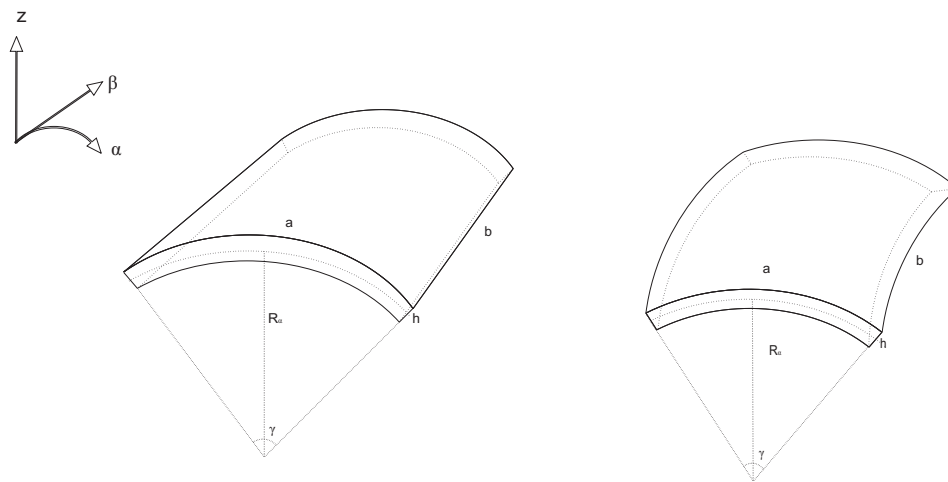

**Figure 1** Geometry and reference system for cylindrical and spherical shells.

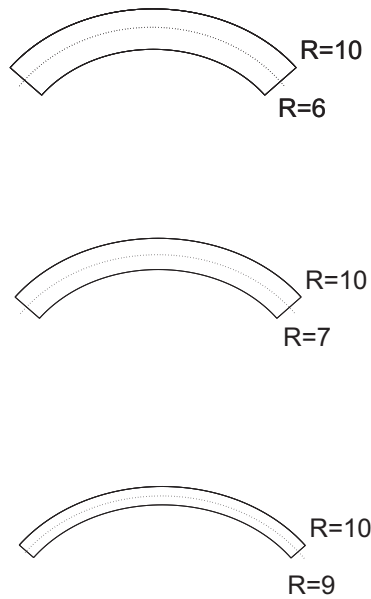

**Figure 2** Case 2 problems, shell with variable thickness parameter  $h/R$ .

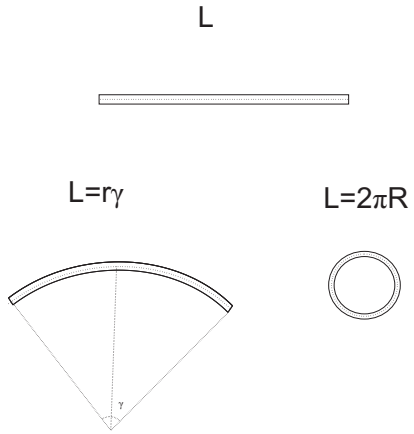

**Figure 3** Case 3 problems, cylindrical shell with variable curvature parameter ( $\gamma$ )

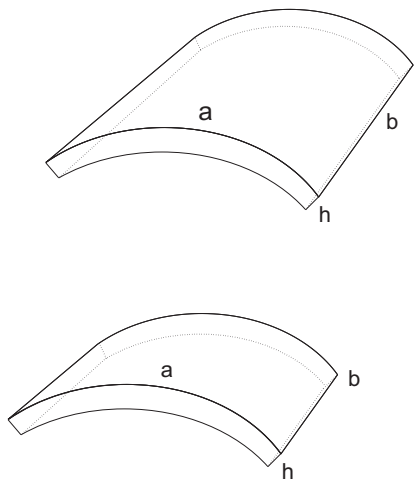

**Figure 4** Case 4 problems, cylindrical shell with variable in-plane aspect ratio  $a/b$ .

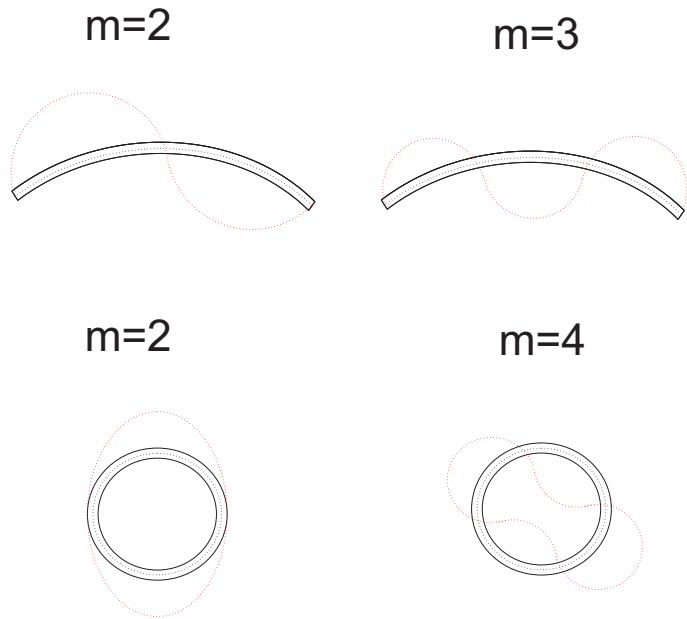

**Figure 5** Vibration modes related to number of waves in cylindrical shell panels.