

FATIGUE CRACK GROWTH IN INHOMOGENEOUS STEEL COMPONENTS

D. Firrao, P. Matteis, P. Russo Spena, G. M. Mortarino

*Dipartimento di Scienza dei Materiali e Ingegneria Chimica
Politecnico di Torino, Italy*



Prof. Donato Firrao
Politecnico di Torino, Italy

INTRODUCTION

Large steel components



Slack quench



Mixed microstructures variable with depth



Paris coefficients influenced by depth

MIXED MICROSTRUCTURES AND PARIS' LAW (I)

- Paris relationship helps solving many problems in case of large components
- In large components there is always a variation of microstructures
- The knowledge of microstructure actually obtained from heat treatment is scarce or not considered in calculations: standard average coefficients are commonly used
- In a medium carbon low alloy component tempered martensite is prevalent in the surface layer; mixed microstructures appear beneath the surface layer: first “tempered” bainite predominates, then pearlite amounts raise at increasing distances from the surface

MIXED MICROSTRUCTURES AND PARIS' LAW (II)

An interuniversity in-depth testing campaign has allowed to assess both microstructure and mechanical properties variations in large quenched and tempered ISO 1.2738 steel blooms and to determine Paris coefficients related to the different microstructures.

The possibility of using the same Paris coefficients, as determined in ISO 1.2738 steel, in case of steel components with similar microstructures encountered at increasing depths, even if made of a different steel, has been hypothesized

MIXED MICROSTRUCTURES AND PARIS' LAW (III)

The effect of variation of Paris law parameters, due to a microstructural gradient, upon the fatigue growth of a surface crack through the section of a large steel component, is discussed on the basis of Fatigue Crack Growth (FCG) calculations, performed in the case of either a slab or a round bar loaded in alternating tension

The crack front is assumed to be an arc of ellipse at all stages of growth; microstructure-dependent Paris coefficients and literature formulas for calculating the Stress Intensity Factor (SIF) values are applied in two different points along the crack front; the deepest (most far from the surface) SIF calculation point encounters varying microstructures as the crack grows.

Results are compared with observation performed on a connection rod that underwent fatigue failure

EXAMINED CONNECTION ROD

Chemical composition (wt. %), AISI 4135 or EN 34CrMo4:

C	Mn	Si	P	S	Cr	Ni	Mo	Al	B
0.36	0.62	0.26	0.012	0.022	1.14	0.25	0.25	0.034	0.001

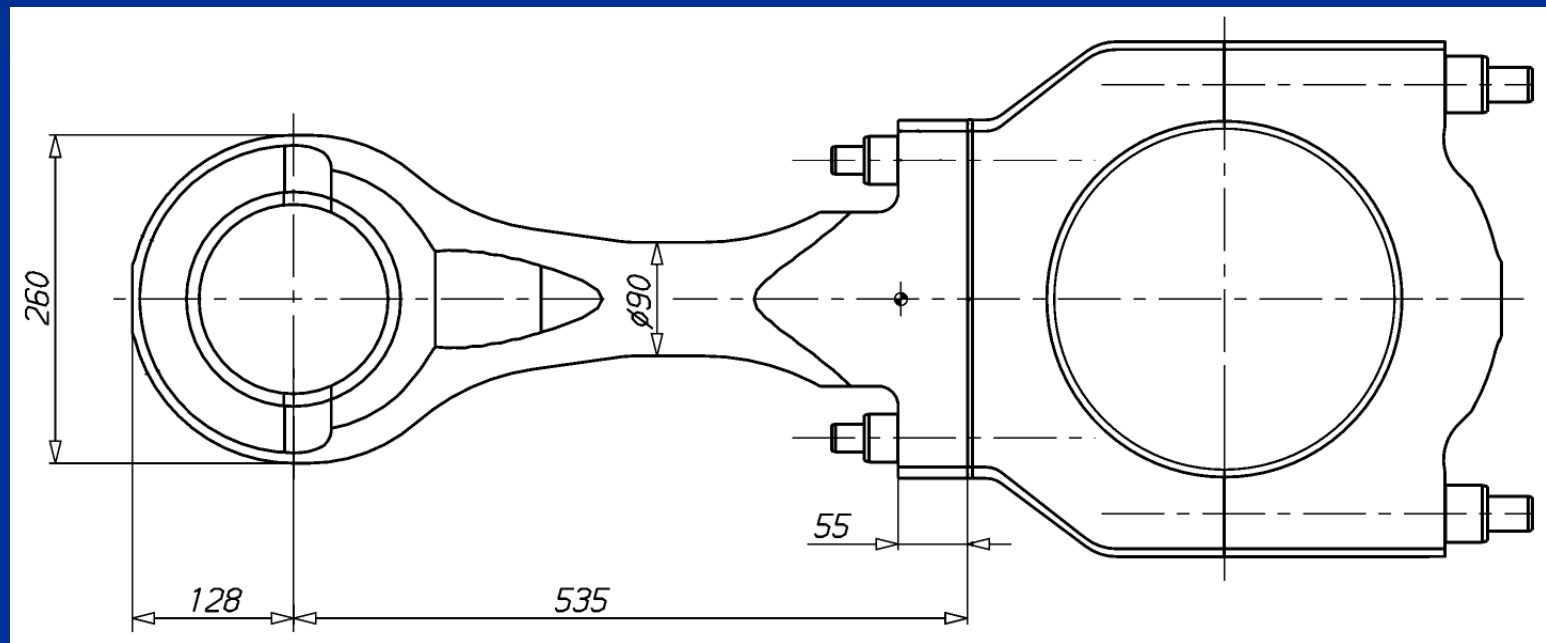

A connection rod (with a 15 mm diameter coaxial lubrication hole) of a 6 cylinders, 2460 kW electricity diesel generator motor.

Constant crankshaft rotation velocity of 750 rpm.

CONNECTION ROD FRACTURE

The fracture occurred in the central cylindrical portion of the component

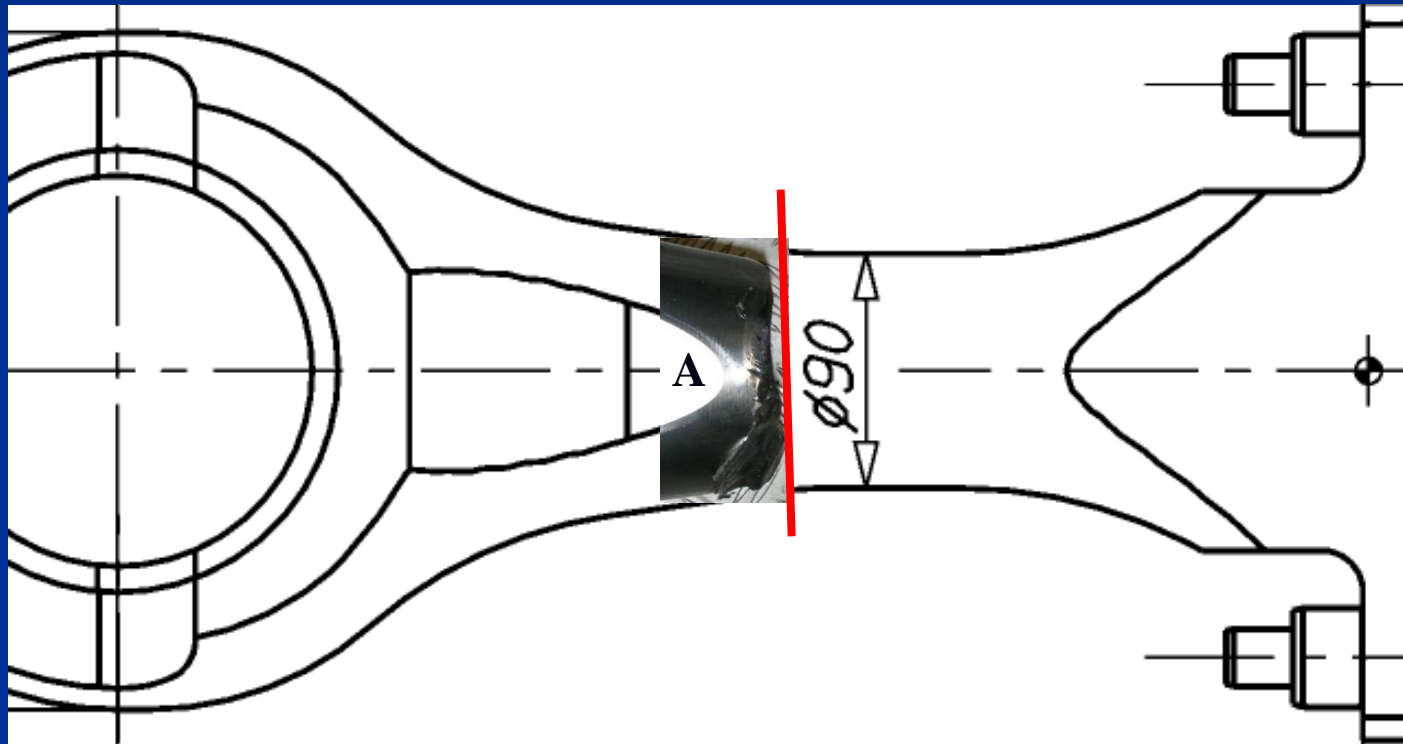

MICROSTRUCTURES

5 mm depth

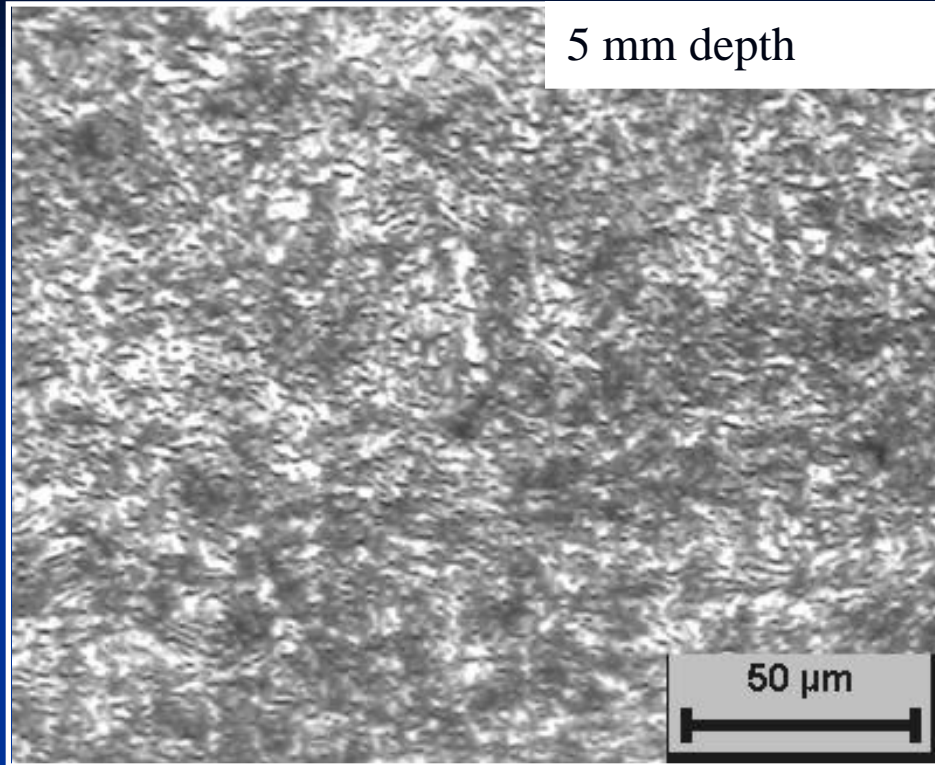

30 mm depth

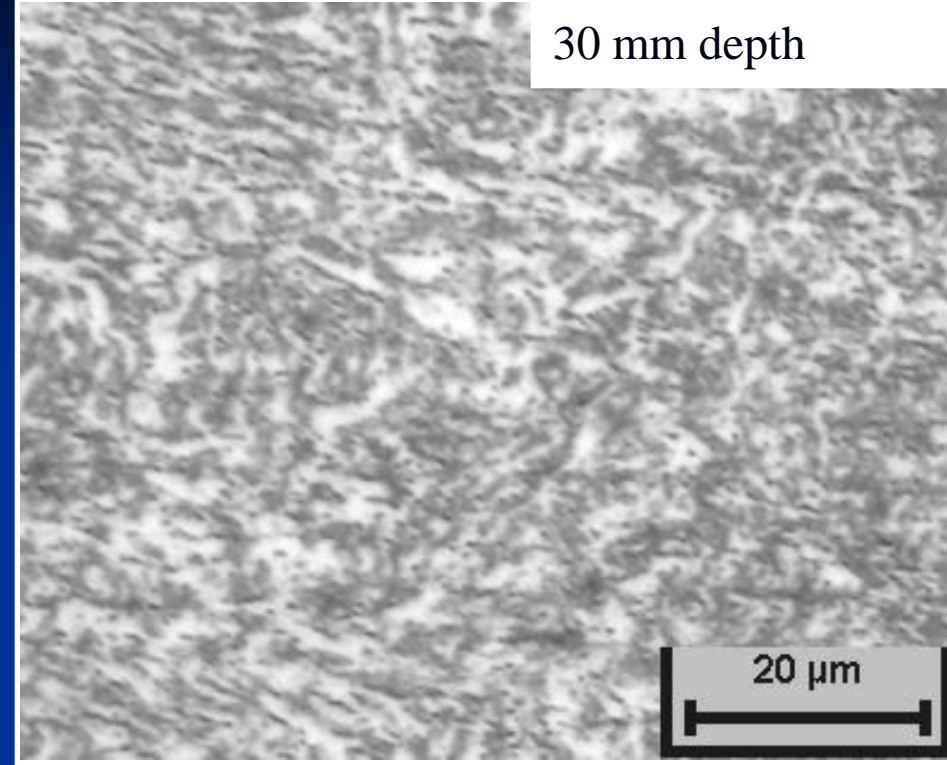

- Martensite tempered slightly above 650 C at the surface
- Tempered martensite/"tempered" bainite, coarse and fine pearlite colonies beyond 22 mm depth
- Pearlite constitutes more than half of the microstructure at 30 mm depth, the rest being a thin ferrite network and some "tempered bainite"

Hardness: 280 HV at the surface; 240-245 HV at about 30 mm depth

FRACTOGRAPHY

Fatigue, outer ring (homogeneous tempered martensite)

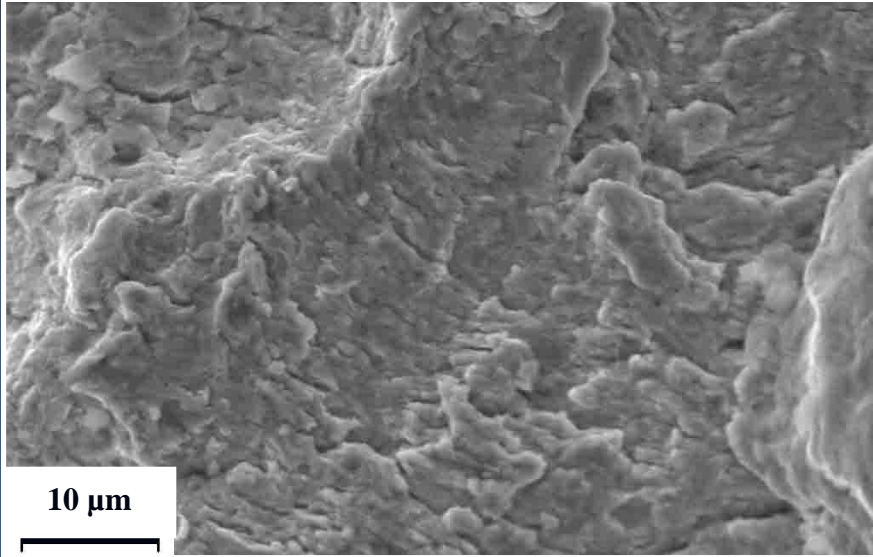

Fatigue, inner ring (mostly pearlite)

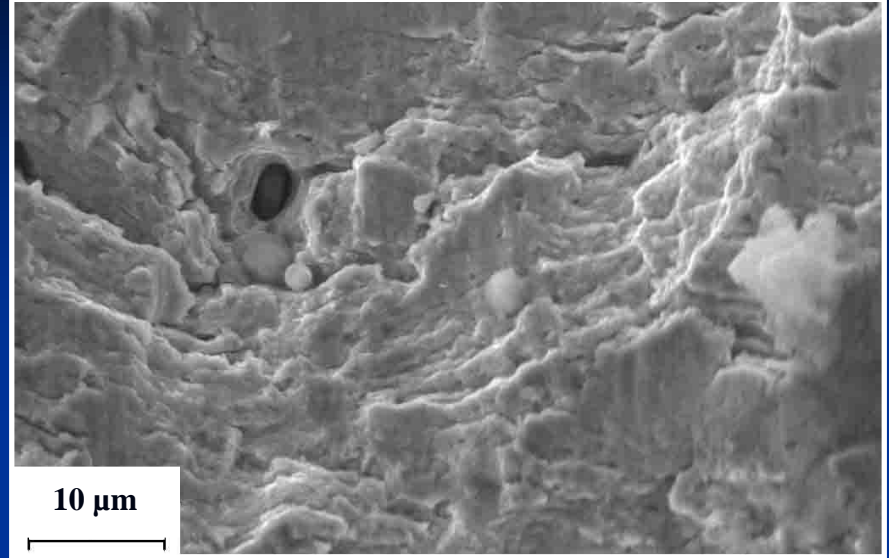

Final overload fracture, outer ring (temp. martensite)

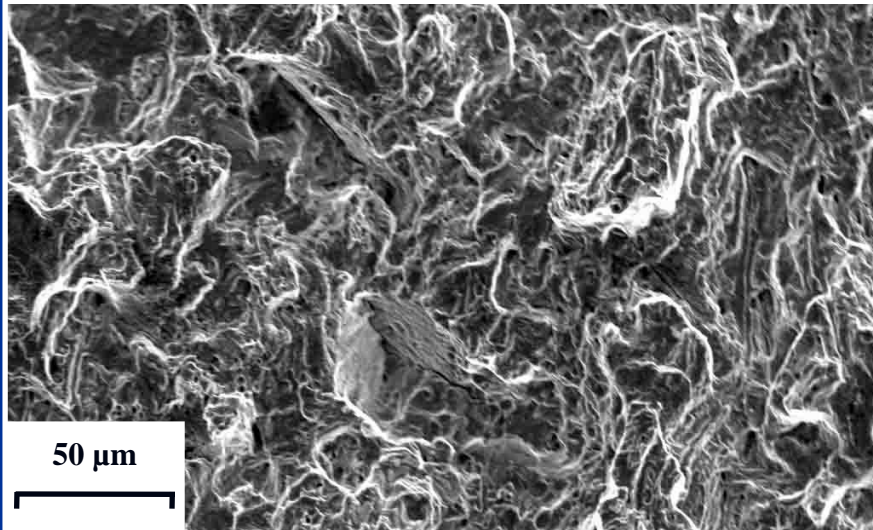

Final overload fracture at core (mostly pearlite)

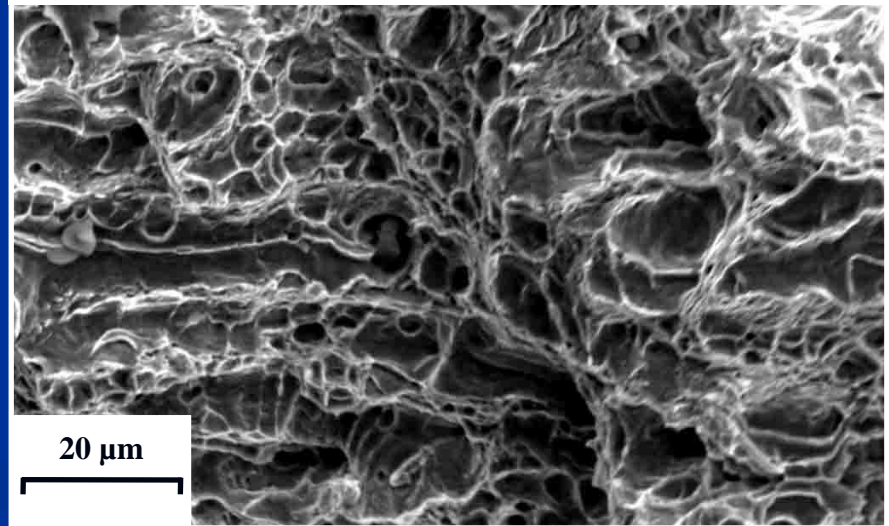

MODEL OF CRACK GROWTH

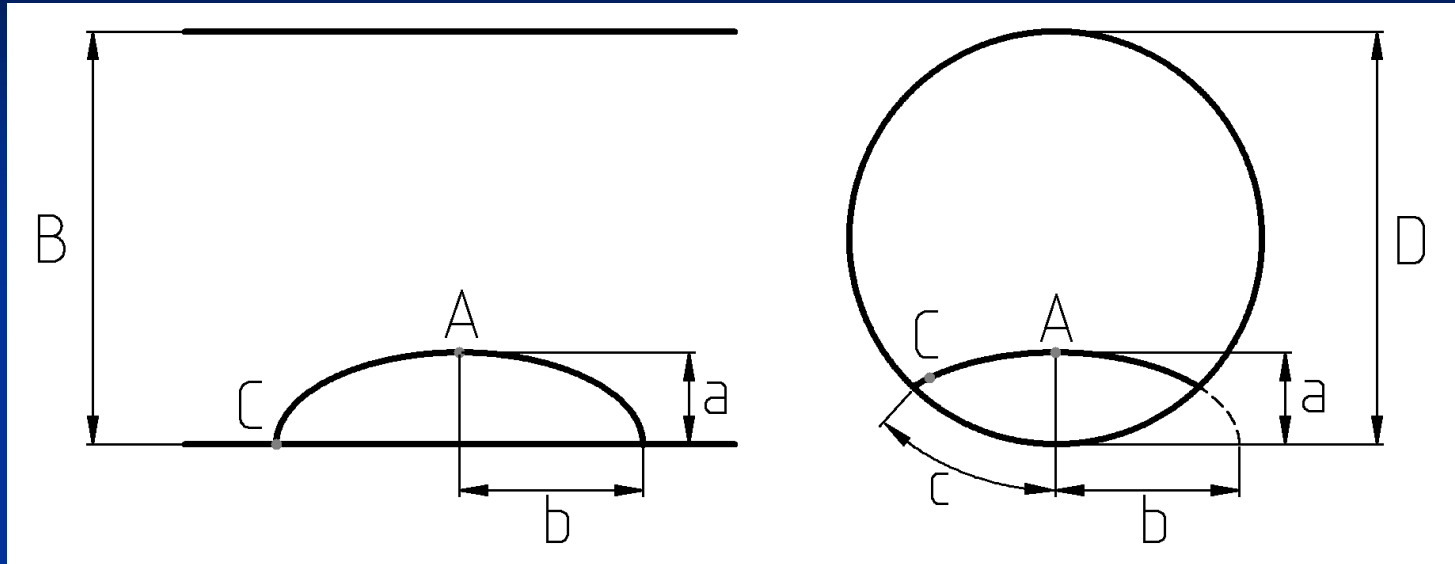

Edge crack in a plate or in a round bar ($B=D$ =Diameter of the connection rod), lying in a plane perpendicular to the free surface and to the loading axis.

The initial crack is assumed to be $a = 4$ mm deep and to have an aspect ratio $a/b = 0.18$, similar to the initial defect of the connection rod.

$\sigma_{\max} = 50$ MPa; $R = 0$; ratio of the minimum and maximum loads.

ASSUMPTIONS

- During FCG, point A moves towards the bar core, whereas point C moves along the bar surface, so that the FCG rate in these two points is differently influenced by the bar microstructure, which can dictate not only the average FCG rate, but also the crack aspect ratio.
- The fraction of tempered martensite is assumed to be 1 at depth 30 mm, to decrease linearly between 30 and 34 mm depth, and to be 0 at depth ≥ 34 mm; the rest is assumed to be pearlite. This choice is based on the hypothesis that, once the fatigue crack encounters a mixed microstructure with some pearlite, it starts to grow preferentially inside the pearlite even if it does not constitute the prevailing constituent; hence it obeys the pearlite FCG behavior as if it were growing in a fully pearlitic microstructure.

FATIGUE CRACK GROWTH

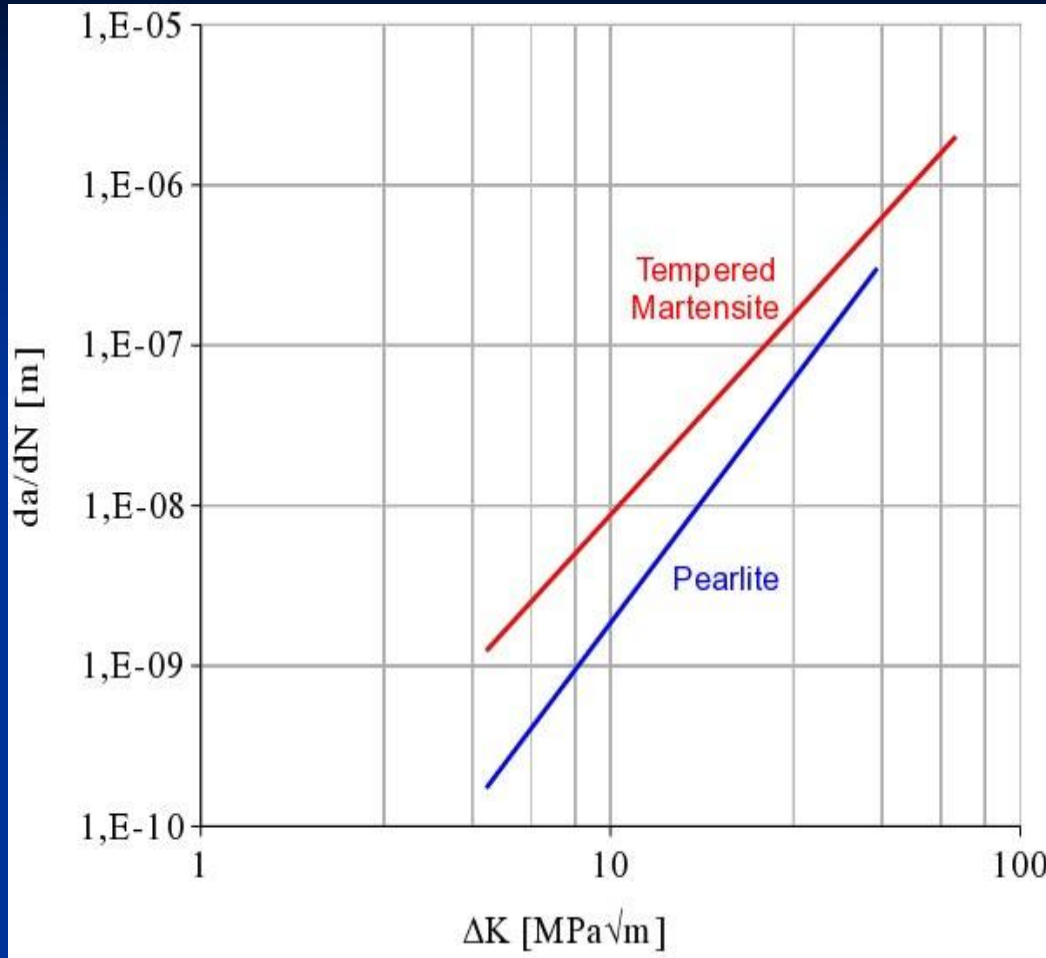

$$da/dN = C \cdot \Delta K^m$$

$$R = 0.1$$

Tempered martensite

(5 - 70 MPa√m ΔK range)

$$C = 1.35 \cdot 10^{-11} \text{ [m} \cdot (\text{MPa}\sqrt{\text{m}})^{-m}]$$

$$m = 2.8$$

Pearlite

(5 - 45 MPa√m ΔK range)

$$C = 7.15 \cdot 10^{-13} \text{ [m} \cdot (\text{MPa}\sqrt{\text{m}})^{-m}]$$

$$m = 3.4$$

- D. Firrao et al. "Fatigue behavior of homogeneous-microstructure and mixed-microstructure steels", In: Plasticity, failure and fatigue in structural materials - from macro to nano: proceedings of the Hael Mughrabi honorary symposium, TMS Annual Meeting & Exhibition 2008, 175-180.

- D. Firrao et al. "Fatigue behavior of homogeneous-microstructure and mixed-microstructure steels", In: Multilevel Approach to Fracture of Materials, Components and Structures, VUTIUM (CZE), 17th European Conference on Fracture, 2008, pp. 2357-2363.

CALCULATED FATIGUE CRACK GROWTH (I)

PLATE:

Calculated fatigue growth of the crack depth a and of the crack half-width b , either with homogeneous tempered martensite microstructure or exhibiting pearlite at core.

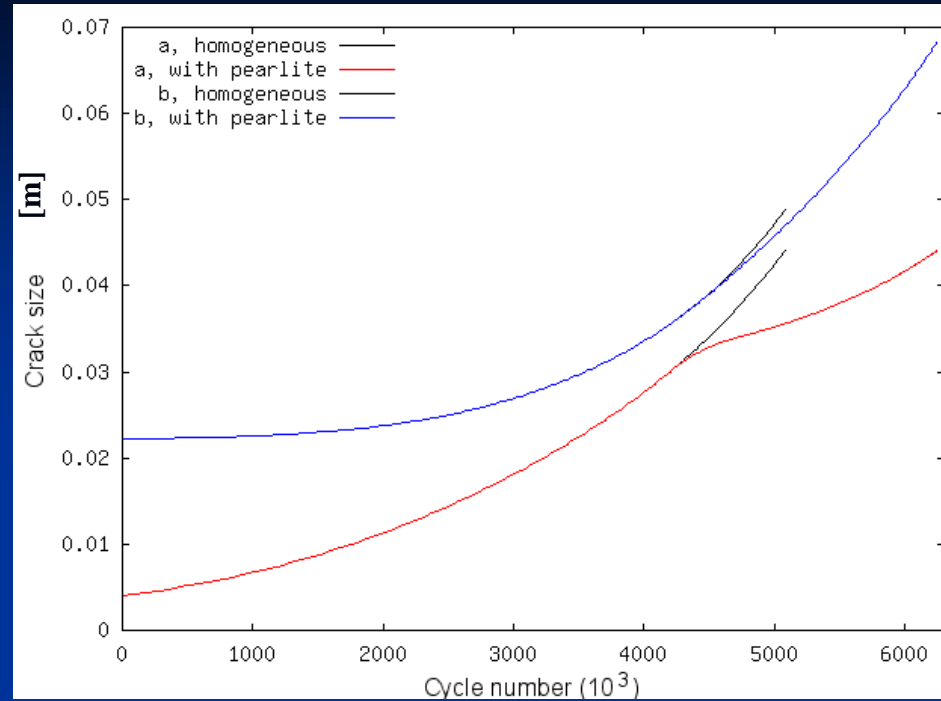

ROUND BAR:

Calculated fatigue growth of the crack depth a and of the crack circumferential half-width c , either with homogeneous tempered martensite microstructure or exhibiting pearlite at core.

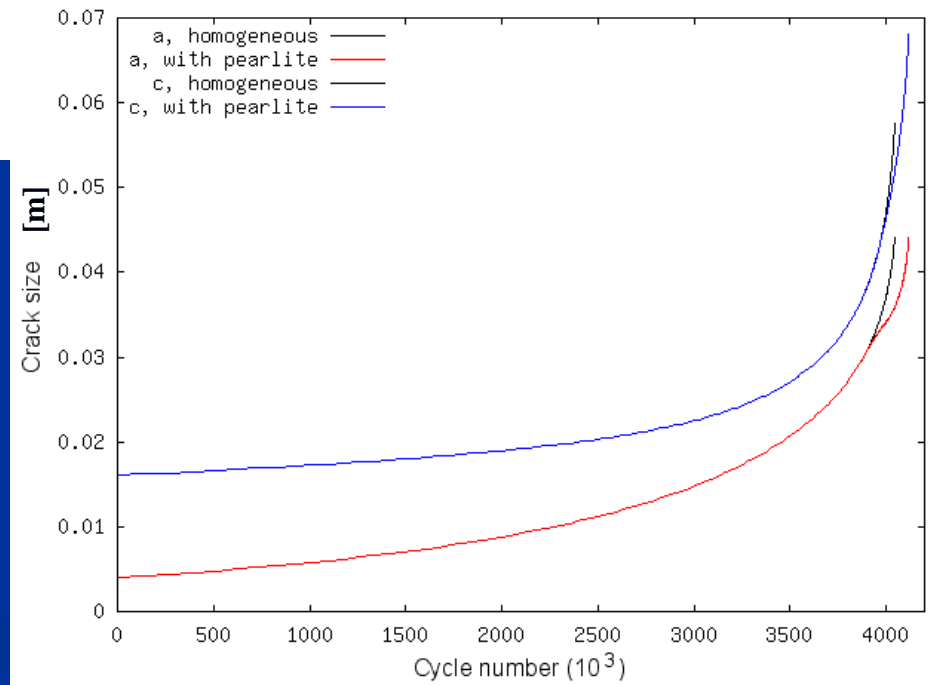

CALCULATED FATIGUE CRACK GROWTH (II)

For homogeneous microstructures, the a/b ratio first increases in both the plate and round bar cases, whereas it exhibits a blunt maximum at about $a/D = 0.3$ in the round bar case. The blunting always occurs in mixed microstructures.

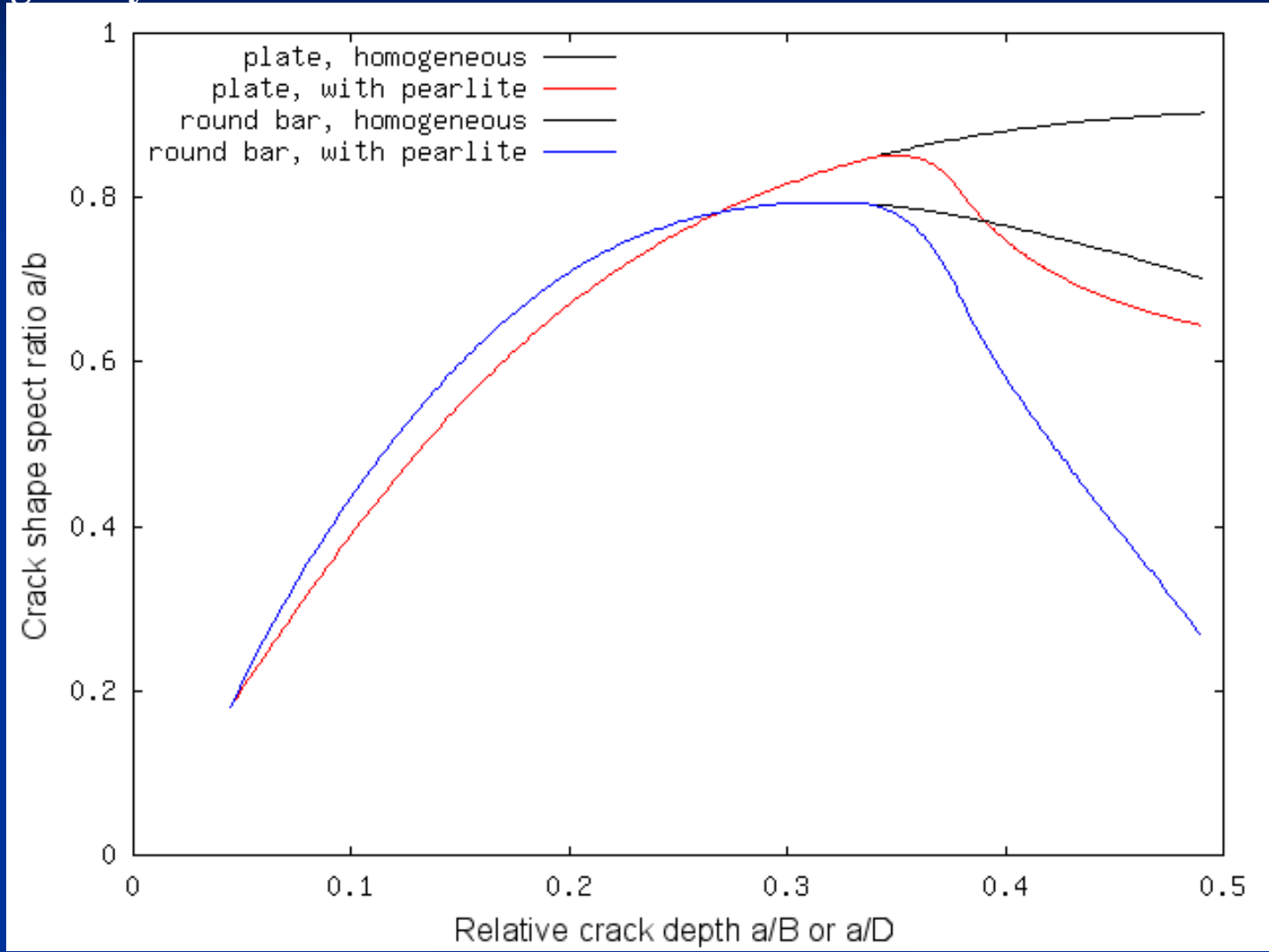

CALCULATED FATIGUE CRACK GROWTH (III) -PLATE

For mixed microstructures in the final stage the crack half-width b increases much more than the crack depth

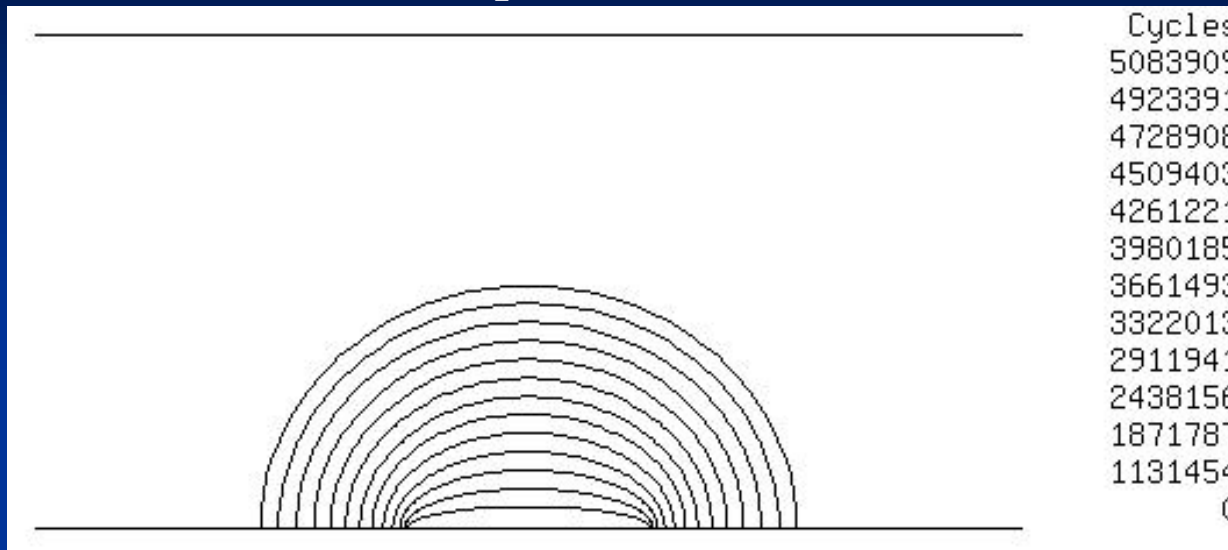

Homogeneous
microstructures
(tempered martensite)

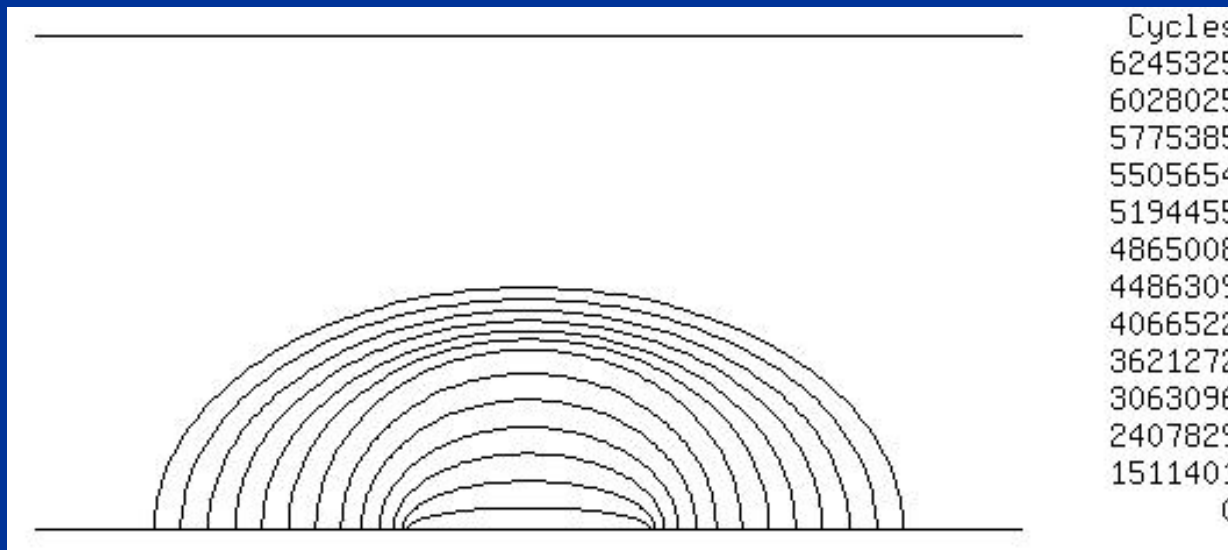

Mixed microstructures
(tempered martensite in
the surface, pearlite at
core)

CALCULATED FATIGUE CRACK GROWTH (IV) - ROUND BAR

For mixed microstructures in the final stage the crack front becomes almost straight

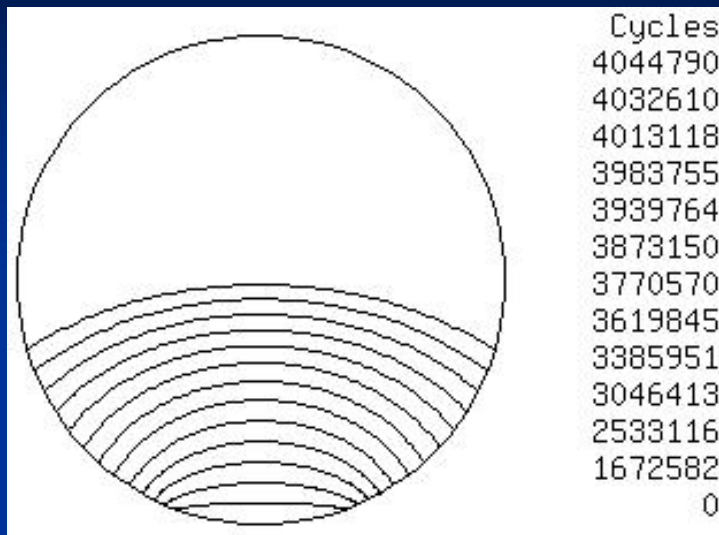

Homogeneous
microstructures
(tempered martensite)

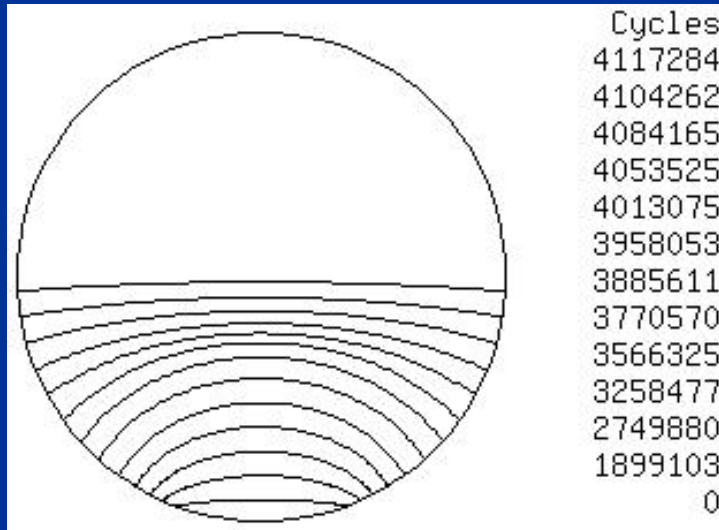

Mixed microstructures
(tempered martensite in
the surface, pearlite at
core)

CONCLUSIONS

The crack propagation in a plate or round bar with a microstructural gradient was simulated and compared with a recent service failure of a 90 mm diameter connection rod.

The simulations show that:

- In both the plate and the round bar cases the crack shape is greatly influenced by the microstructure
- Microstructural gradients cause large variations in the crack shape, even if the difference in the FCG behavior is small.
- The lower FCG rate of the pearlite causes the straitening of the crack front when it reaches the mostly pearlitic core.
- The latter result is compatible with the fractographic analysis of the connection rod, hence it can be used as a proof of an inhomogeneous microstructure in failure analyses.

FATIGUE CRACK GROWTH IN INHOMOGENEOUS STEEL COMPONENTS

D. Firrao, P. Matteis, P. Russo Spena, G. M. Mortarino

*Dipartimento di Scienza dei Materiali e Ingegneria Chimica
Politecnico di Torino, Italy*



Thank you for your attention