

Economical comparison of CHP systems for industrial user with large steam demand

*Original*

Economical comparison of CHP systems for industrial user with large steam demand / Giaccone, L.; Canova, A.. - In: APPLIED ENERGY. - ISSN 0306-2619. - ELETTRONICO. - 86:6(2009), pp. 904-914. [10.1016/j.apenergy.2008.10.025]

*Availability:*

This version is available at: 11583/1876137 since: 2018-03-29T15:54:25Z

*Publisher:*

Elsevier

*Published*

DOI:10.1016/j.apenergy.2008.10.025

*Terms of use:*

This article is made available under terms and conditions as specified in the corresponding bibliographic description in the repository

*Publisher copyright*

(Article begins on next page)

# Economical comparison of CHP systems for industrial user with large steam demand

Aldo Canova      Luca Giaccone \*

November 30, 2008

## Abstract

In this paper cogeneration benefits applied to a user with a high steam demand are analyzed. The methodology for the feasibility study and the economical analysis of the investment is presented under the Italian legislative framework. The methodology is applied to an actual case and a detailed description and discussion of all data input is provided. Especially this last key point will be faced using starting data usually available in these kind of studies (i.e. not very detailed for thermal consumption). Finally a comparison of different CHP technologies and a sensitivity analysis is done.

cogeneration; CHP; economical analysis; steam; ICE; turbogas

---

\*Politecnico di Torino, Dipartimento di Ingegneria Elettrica, corso Duca Degli Abruzzi, 24  
- 10129 Torino, Italy ([luca.giaccone@polito.it](mailto:luca.giaccone@polito.it))

## Nomenclature

### Acronyms

|      |   |
|------|---|
| AEEG | Authority for the Electrical Energy and Gas |
| CHP  | Combined Heat and Power                     |
| CHCP | Combined Heat, Cooling and Power            |
| CF   | Cache Flow                                  |
| DPBP | Discounted Pay Back Period                  |
| ICE  | Internal Combustion Engine                  |
| SB   | Single Buyer                                |
| GT   | Gas Turbine                                 |

### Symbols

|                   |   |
|-------------------|---|
| $c_{av\_Fi}$      | average electrical energy price in the $F_i$ range [€/kWh]  |
| $c_{el}$          | average price of the electrical energy bought by the user [€/kWh]   |
| $c'_{el}$         | average price of the electrical energy bought by the user without considering the energy in range $F_4$ [€/kWh] |
| $c_{ng}$          | average natural gas price [€/m <sup>3</sup> ]   |
| $c'_{ng}$         | natural gas price with tax reduction [€/m <sup>3</sup> ]  |
| $c_{pg}$          | specific heat of the exhaust gas at constant pressure [J/kg/K]  |
| $c_{SB\_Fi}$      | single buyer prices in range $F_i$ [€/kWh]  |
| $d$               | discount rate   |
| $E_{el\_tot}$     | total annual electrical energy produced by the CHP unit [kWh]   |
| $h_{gas}$         | enthalpy of water in saturated vapour state (180 °C and 10 bar) [J/kg]  |
| $h_{liquid}$      | enthalpy of water in saturated liquid state (180 °C and 10 bar) [J/kg]  |
| $h_{180^\circ C}$ | enthalpy of water at 180 °C and 10 bar [J/kg]   |
| $h_{80^\circ C}$  | enthalpy of water at 80 °C and 10 bar [J/kg]  |
| $I_0$             | total initial investment [€]  |
| LHV               | lower Heating Value of the natural gas [kWh/m <sup>3</sup> ]  |
| $\dot{m}_{AV}$    | average steam flow demand in summer/winter period [kg/s]  |
| $\dot{m}_{eg}$    | exhaust gas flow of the machine [kg/s]  |
| $\dot{m}_{UA}$    | average steam flow demand in summer/winter of Unit A [kg/s]   |
| $\dot{m}_{UB}$    | average steam flow demand in summer/winter of Unit B [kg/s]   |
| $\dot{m}_{UC}$    | average steam flow demand in summer/winter of Unit C [kg/s]   |
| $\dot{m}_{steam}$ | maximum steam flow producible [kg/s]  |
| $\dot{m}_{ud}$    | user demand of steam flow [kg/s]  |
| $\dot{m}_{UT}$    | average steam consumption in summer/winter of Utilities [kg/s]  |
| $\dot{m}_x$       | average steam flow demand in summer/winter of the Unit/utilities x [kg/s]                                       |

continued on next page...

...continued from previous page

|                          |   |
|--------------------------|---|
| $M_{tot}$                | total steam consumption in summer/winter period [kg]  |
| $M_X$                    | steam consumption in summer/winter period of a Unit/utilities [kg]                              |
| $n_{h_{Fi}}$             | number of working hours in range $F_i$ [h]  |
| $n_{h_{tot}}$            | total working hours in summer/winter period [h]   |
| $n_{h_X}$                | total working hours of each Unit [h]  |
| $p_X$                    | percentage of the total steam consumption of each Unit/utilities                                |
| $P_{av_{Fi}}$            | average absorbed electrical power in range $F_i$ [kW]   |
| $P_{E_{U_i}}$            | electrical power absorbed by the user in $\Delta t_i^{casej}$ , with $j= 2$ or $3$ [kW]         |
| $P_{E_{CHP_i}}$          | electrical power produced by the CHP in $\Delta t_i^{casej}$ , with $j= 2$ or $3$ [kW]          |
| $P_{econ}$               | thermal power exchanged in the economizer [kW]  |
| $P_{lim}$                | theoretical thermal power flow between the exhaust and the steam circuit [kW]                   |
| $P_{MAX_{evap}}$         | maximum thermal power flow between the exhaust and the steam circuit [kW]                       |
| $P_{rec_{tot}}$          | total thermal power recovered [kW]  |
| $t_{steam}$              | temperature of the steam that has to be produced [ $^{\circ}C$ ]                                |
| $v_{ng}$                 | total annual volume of natural gas burned in the CHP [ $m^3$ ]                                  |
| $v'_{ng}$                | annual volume of natural gas burned in the CHP with tax reduction [ $m^3$ ]                     |
| $\text{€}_{ng}$          | annual cost of the CHP fuel [€]   |
| $\text{€}_{ESC}^{case2}$ | total saving due to the selfconsumption of electrical energy in all the cases 2 of one year [€] |
| $\text{€}_{ESC}^{case3}$ | total saving due to the selfconsumption of electrical energy in all the cases 3 of one year [€] |
| $\text{€}_{ES}^{case2}$  | total profit due to the selling of electrical energy in all the cases 2 of one year [€]         |
| $\text{€}_{ESC}$         | total saving derived from selfconsumption of the electrical energy produced by the CHP [€]      |
| $\text{€}_{ES}$          | total profit derived from selling the excess of electrical energy produced [€]                  |
| $\Delta t$               | time step for the electrical energy balance [h]   |
| $\Delta t_i^{case2}$     | $\Delta t$ number $i$ belonging to case 2 [h]   |
| $\Delta t_i^{case3}$     | $\Delta t$ number $i$ belonging to case 3 [h]   |

## 1 Introduction

Concerning the recent energetic problems the necessity of a better use of primary resources is unavoidable. In this background the cogeneration, also known as *Combined Heat and Power* (CHP), is a good solution for users who ask for energy savings. In last years the attention on CHP is increased, and also the European Community helps the initiatives which aim to improve the energy efficiency of the existing networks by using CHP systems. Concerning the sixth framework there are some EU projects in the field of sustainability and energy saving. Result, discussion and ideas of these projects are collected from CON-

CERTO PLUS project [1]. Just to give an example, POLYCITY [2] is one of the projects belonging to CONCERTO initiative, within this demonstration project the installation of a natural gas CHP system combined to a district heating system is foreseen.

The economical analysis is a way to justify the installation of a CHP unit and evaluate its profitability. Of course this last point is tightly dependent on the user consumption, both electrical and thermal. Hereinafter, the state of art of the economical studies applied to cogeneration and trigeneration system will be described in order trying to highlight the user consumption data which usually are available in these studies.

Maidment *et al* [3] present the results of an investigation into the practical economic viability of an integrated combined heating and cooling system in a supermarket. They describe a model which is used to simulate the energy consumption of a supermarket with different supply systems. They use this model in order to compare the conventional technology for energy production with a CHCP system. They conclude that a gas engine is suitable to provide both heating and cooling in a supermarket and, concerning the management of the machine, they highlight how the “off-peak” electricity tariff makes the use of the electricity from the grid more attractive with respect to the selfproduction.

Kosugi *et al* [4] present an economic feasibility study for a natural gas-fired combined heat and power facility in a Chinese industrial area. They develop a model which optimizes the CHP installation capacity under the constraint of the electricity/heat supply and demand balance, furthermore, energy cost and emissions are taken into account. The energetic data used in their model are based on literature and interview surveys. Their conclusions are mainly focused on the pollutant emission which, at the moment, are just taken into account as externalities. They highlight how the internalization of the externalities would be the most important incentive for cogeneration.

Khan *et al* [5] present the study of a cogeneration system with thermal energy storage both from technical and economical point of view.

The application includes a building which needs only electricity. Typical electrical and cooling load profile have been derived from measurement. They take as case study the Asian Institute of Technology which requires electricity and cooling (not thermal energy). The supply system composed by CHP thermally coupled with an absorption chiller is analyzed. Furthermore, also the adding of a thermal storage system has been studied. Their analysis is based on the measured consumption data of the building. Their aim is to highlight how the saving potential can be limited by the low demand of chilled water during some period of the day. Hence, they conclude that the supply system has to be integrated by a thermal storage system in order to decouple supply and demand side.

Cardona and Piacentino [6] present an optimization method for the design of a CHCP plant. The model is based on aggregate energy-flows or energy flow-rates which have been simulated with a model developed by the same authors. The method is applied to a 300-bed hospital in order to prove the efficiency of the optimization method concluding with the observation that hospitals are a

good user category for the installation of a CHCP system.

Arcuri *et al* [7] present a mixed integer programming model for finding the optimal design and the optimal management strategy of a trigeneration system in a hospital complex. Their model needs the energetic load profiles of the user which have been derived with simplified hypothesis based on the user typology. As well as Cardona and Piacentino [6] they prove how a CHCP system can be a good solution for a hospital. Moreover, they focus the attention on the environmental aspects highlighting that, especially for a public body, the reduction of management costs should be a priority as well as the social costs.

Medrano *et al* [8] present a study about the integration of distributed generation systems into generic types of buildings (Office buildings, health care buildings and education buildings). Building requirements are analyzed deriving the hourly load profiles using the whole-building energy analysis software DOE-2. First of all Energy Efficiency measures have been analyzed, then, three DG technologies are taken into account: high-temperature fuel cells, micro-turbines and photovoltaic systems). These three DG technologies are combined to create different CHP and CHCP system (adding a double effect absorption chiller). After the analysis of several application results, they point out that Energy Efficiency measures should be considered before attempting a DG building integration because those measures can contribute to important energy savings with minor investment. Moreover, they highlight how the hourly load profile of the user are the key for a better understanding of the building energy consumption. Finally, in agreement to references [6, 7], they find in the hospitals the most suitable category for the installation of a CHCP system.

Farghal *et al* [9] have presented an optimization method aimed to find optimum operation problems of different cogeneration alternatives devoted to the production of electricity and steam for industrial users. Their optimization model aim to the minimization of the plant costs and it is applied to four cases based on gas turbines technologies. The results of their study confirm that gas turbines can be a good solution for this kind of application observing that, sometimes, the best economical solution is not always the most efficient one. Moreover, they suggest the utilization of probability functions to represent the dynamic nature of loads in order to obtain the most accurate results.

Karagiannis [10] describes a case study where a CHP system based on two gas turbines is installed to supply energy to a groups of buildings in Athens. The buildings requirement have been characterized by means of the load duration curves. These data are used as input for the economical assessment of the investments.

Shah and Krishnan [11] have done an economical evaluation of the CHP profitability for installation in Data Centers based on the Life Cycle Assessment methodology. Their analysis employs electrical load profile defined with reference to the state of art on the typology of the user, and the thermal load profile calculated with a common methodology [12] starting from the standard space heating properties of the data centers. The study finds that the benefits availed by implementing CHP may be small in the short run and depend largely on the size and configuration of the data center infrastructure. However, under

certain operating circumstances, both environmental and economic gains can be realized.

Ratajczak and Li [13], after an introduction of the principle of cogeneration, give a methodology for the basilar economical analysis of CHP systems. This analysis is applied to a small food processing plant whose electrical and thermal loads are defined with reference to the user typology and supposed constant along the years. The paper identifies many different types of energy consumers which could have a high potential for benefit from the implementation of a cogeneration system. These energy consumers should have large electric load as well as a large thermal load and should also have energy costs, electrical and thermal, that make the construction and operation of a cogeneration system economically feasible.

Jablko *et al* [14], after a market analysis on micro CHP technologies, have done an economical analysis on micro CHP units which supplies a single family home. They take into account different CHP technologies: fuel cells, stirling engines, internal combustion engines, micro gas turbines and steam engines. Their work is very detailed from the data measurement point of view. The electrical and thermal load profile with time resolution of 1 minute are available. They summarize this big amount of data in 12 typical days (3 for each season) in order to do the economical analysis. The results indicate that only a few micro CHP plants are appropriate for use in a single-family home. Most of the evaluated plants have a rated power that exceeds the energy demand of a single-family home.

Chicco and Mancarella [15] illustrate and evaluate the possible benefits of adopting different trigeneration alternatives in the design of a new energy system, with the specific focus on comparing different cooling production solutions. The comparative analysis of the trigeneration solutions is carried out for a hospital site, by performing time-domain simulations to characterize the out-of-design operation and different regulation strategies of the equipment. The time domain simulation is done by using standard thermal and cooling load profiles identifying three typical days. The evolution of the electrical hourly demand is assumed to be the same for the three typical days. Their results indicate that the traditional energy efficiency indexes used for evaluating the performance of cogeneration plants do not take into proper account all the CHCP operating conditions, all the interactions among the equipment, and all the energy flows inside the whole energy system.

Canova *et al* [16] present a a mixed integer linear model aimed to find the optimal energy management of a system composed by several kind of loads (electrical, thermal, cooling) and energy sources (external network, CHPs, boilers, chillers). The optimizer manages on/off status of CHPs and boilers and their level of power production and power rate of chillers. An office building is chosen as case study for the application of the model. The optimizer needs as input the energy load profiles of the user. The electricity load profile has been measured while the thermal one has been estimated with relation to the user typology). The result of the optimization can be used for the economical assessment of the solution, hence the optimized CHP management is compared with the classical

manual CHP management obtaining good results. In agreement with reference [3] the optimizer turns off the CHP during the “off-peak” hours because, the low electricity tariff, makes economically convenient the use of electricity from the grid.

Looking at the state of art it is possible to see that often realistic and detailed data of the user energy consumption are not available, hence, some standard or simulated load profiles have to be used which could lead to less accurate results. Moreover, as frequently happens, the information is quite sufficient regarding the electrical consumption and poor concerning the thermal ones [3, 4, 6, 7, 8, 9, 11, 13, 15, 16]. Furthermore, the methodology which allows to reach the economical indicators, in most of the analyzed references, is just outlined without going into details.

Since the good evaluation of the user energy demand is the key point in order to obtain good results, in this paper a methodology which allows to provide a good economical analysis starting with detailed electrical consumption data and rough thermal consumption data will be shown and detailed. The methodology will be explained performing a feasibility study of a CHP system which will supply electricity and steam to an industrial user.

Finally, cogeneration can be done by means of several technologies [17]. The one which best fits the user request can be determined through the economical analysis. In this paper two different technologies will be analyzed: Internal Combustion Engine (ICE) and Gas Turbines (GT). For a fast comparison between the two solutions, it should be noted that: ICEs are based on a consolidated technology, they have high efficiency, reliability and modularity. On the other hand high noise level, emissions, maintenance costs and low cogeneration quality are the drawbacks of this technology. Concerning GTs: they have small dimensions and weights, short time of installation, low emissions, vibration and noise, high cogeneration quality and long operational life. The drawbacks of GTs are: low electrical efficiency (especially for small size), requirement of high quality of fuel and, finally, for small sizes the price is relatively high.

## 2 User consumptions analysis

The first step of a feasibility study is the User Consumptions Analysis from which the economic profitability tightly depends. Usually it is easier to get detailed electrical consumption data rather than the thermal ones. This is mainly due to the fact that electrical load measurements are easier to do than the thermal ones and also the technologies for spot electrical measurement are more available on the market. Therefore, in this paragraph a methodology which allows to do a good user consumption analysis is presented. The energy data which will be used in this section are:

- Electrical load profile of one year with one hour of time resolution
- Average thermal consumption for summer period and winter period



## 2.1 Electrical consumptions

The input data are the electrical load profile for one year with one hour of time resolution. This detailed load measurement is related to the *time bands* defined by the Italian Authority for the Electrical Energy and Gas (AEEG). At the time of the analysis, the time bands were the four summarized here below:

- **F1:** peak-level hours,
- **F2:** high-level hours,
- **F3:** mid-level hours,
- **F4:** off-peak hours.

The subdivision of the year in time bands is not constant, every year the AEEG has to define a new subdivision due to the variability of the holiday periods. In Fig. 1 the average electrical load profiles for every month are shown. The user under analysis employs a work cycle which is not stopped during the night. This is the justification to the electrical load profile shape which is quite constant during all the year/month/day. The average consumption is lower just in August because, in this month, the industrial activity is stopped for summer holidays. A deeper detail of the user working cycle can be found in section 2.2.

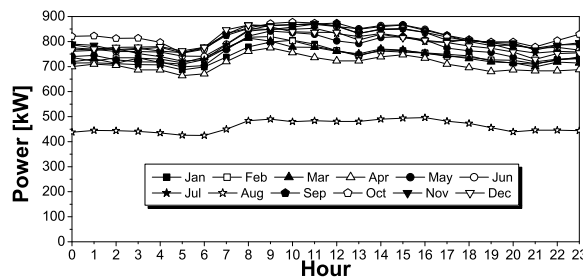

Figure 1: Electrical load profile of the industrial user - Average profile for each month

## 2.2 Thermal consumptions

In Fig. 2 the thermal plant layout of the user is represented. The boiler is fed by natural gas in order to obtain the primary energetic vector of the plant, i.e. diathermic oil. The user is subdivided in three units and some utilities where different kinds of work are carried out. The 70% of diathermic oil energy is used in the Unit C while the remaining 30% is used in the Indirect Evaporator in order to produce Steam at  $180^{\circ}C$  and 10 bar. The steam is used in all the Units and by the Utilities of the user according to the following scheme:

- **Unit A:**
  - Working cycle: 5 days/week from 7 to 19
  - Consumption: 30% of steam
- **Unit B:**
  - Working cycle: 5 days/week 24/24 hours
  - Consumption: 50% of steam
- **Unit C:**
  - Working cycle: 7 days/week 24/24 hours
  - Consumption: 10% of steam consumption
  - Closure: 20 days per year during summer and winter holidays
- **Utilities:**
  - Working cycle: 5 days/week
  - Consumption: 10% of steam consumption
- **Closure of the industrial activity:** 20 days per year subdivided in the August and December holidays.

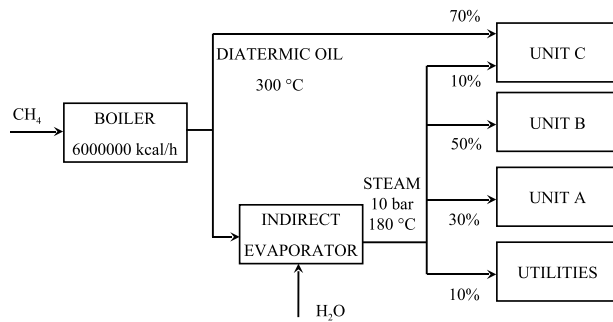

Figure 2: Thermal plant layout of the user with consumption percentage of the thermal energetic vectors

As it is clear from the analysis of Fig. 2, the user has a large steam demand. Hence, the CHP thermal output will be recovered by producing steam.

Considering the consumption percentage and the average demand which is 2t/h and 4t/h in summer and winter period respectively, the load profile of four *typical days* can be derived:

1. summer week day.
2. summer week-end day.

3. winter week day.
4. winter week-end day.

First of all the total working days for summer and winter have to be evaluated. With reference to the considered year and from the information about the working cycle of the user, Table 1 and 2 have been filled. It should be stressed that the input data are relative to the whole considered year which has been subdivided only in summer and winter. As it is clear from Table 1 and 2, this subdivision will include also spring and autumn.

Table 1: Working days summary for summer season

| Month                            | Working                    | Working       |
|----------------------------------|----------------------------|---------------|
|                                  | week days                  | week-end days |
| APR                              | 20                         | 10            |
| MAY                              | 22                         | 9             |
| JUN                              | 21                         | 9             |
| JUL                              | 21                         | 10            |
| AUG                              | 17                         | 4             |
| SEP                              | 22                         | 8             |
| <b>Total working Summer days</b> |                            |               |
| <b>Total week days</b>           | <b>Total week-end days</b> |               |
| 123                              | 50                         |               |
| 173                              |                            |               |

The average consumption of all the Unit/Utilities in summer and winter period can be evaluated following this approach:

$$M_{tot} = \dot{m}_{AV} \cdot n_{h_{tot}} \quad (1)$$

$$M_X = M_{tot} \cdot p_X \quad (2)$$

$$\dot{m}_x = M_X / n_{h_x} \quad (3)$$

The obtained results allow to derive an approximation of the thermal load profile for the four typical days, for the sake of brevity just one typical day will be taken as example. Hence, referring to the typical winter week day, the steam demand can be derived as given by the following expression:

$$\dot{m} = \begin{cases} 7 \text{ to } 19: & \dot{m}_{UA} + \dot{m}_{UB} + \dot{m}_{UC} + \dot{m}_{UT} \\ 0 \text{ to } 7 \text{ and } 19 \text{ to } 23: & \dot{m}_{UB} + \dot{m}_{UC} + \dot{m}_{UT} \end{cases}$$

In Fig. 3 (summer days) and 4 (winter days) the four typical days calculated by means of this approach are shown.

Table 2: Working days summary for winter season

| Month | Working   | Working       |
|-------|-----------|---------------|
|       | week days | week-end days |
| JAN   | 20        | 11            |
| FEB   | 20        | 8             |
| MAR   | 23        | 8             |
| OCT   | 21        | 10            |
| NOV   | 21        | 9             |
| DEC   | 14        | 7             |

| Total week days | Total week-end days |
|-----------------|---------------------|
| 119             | 53                  |

| Total working Winter days |
|---------------------------|
| 172                       |

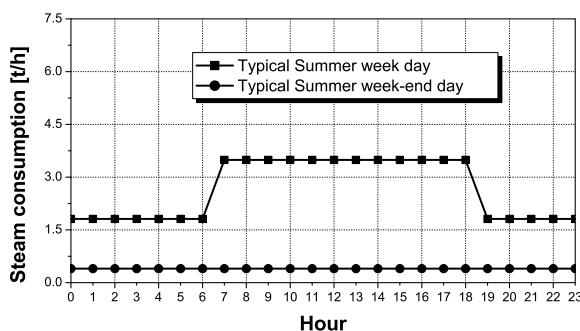

Figure 3: User steam demand - Typical summer days

### 2.3 Average energy prices

The user consumption analysis also consists in the characterization of the electrical/thermal average energy prices in order to evaluate the future savings due to the CHP installation. This simple evaluation can be done by the analysis of the user's energy bills. It is important to calculate the average prices over a period of at least one year.

As will be shown in the following, the savings will be evaluated using the average price of electrical energy and the average price of natural gas and these values will be derived from the user consumption analysis. Here the calculation

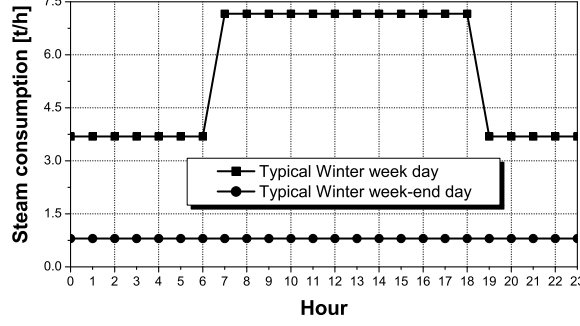

Figure 4: User steam demand - Typical winter days

of the average electrical energy price is explained. The average price of natural gas will be discussed during the operational costs calculation (section 4.3).

Unfortunately, the electrical bill of the user under analysis just allows to calculate the total average electrical energy prices ( $c_{el}$ ), i.e. the average price which includes the consumption in all the time bands (F1, F2, F3 and F4). Considering that, for economical reasons of profitability, the CHP is turned off during the off-peak hours (time band F4) [3, 16], it should be more accurate to evaluate the average price of the electrical energy purchased in the time band F1, F2 and F3 because, excluding the off-peak hours, the actual reference price for the economic saving due to the selfproduction of electrical energy can be calculated ( $c'_{el}$ ).

Although ( $c'_{el}$ ) is not directly available, some hypotheses can be done in order to evaluate it. An analytical expression of the total average price is given by:

$$c_{el} = \frac{\sum_{i=1}^4 P_{av-Fi} \cdot n_{h-Fi} \cdot c_{av-Fi}}{\sum_{i=1}^4 P_{av-Fi} \cdot n_{h-Fi}} \quad (4)$$

As already said, the CHP is turned off during the time band F4. Hence, the average price which does not consider this time band is needed:

$$c'_{el} = \frac{\sum_{i=1}^3 P_{av-Fi} \cdot n_{h-Fi} \cdot c_{av-Fi}}{\sum_{i=1}^3 P_{av-Fi} \cdot n_{h-Fi}} \quad (5)$$

Equation (4) can be modified in order to highlight the price  $c'_{el}$ :

$$\frac{c_{el} \sum_{i=1}^4 P_{av-Fi} \cdot n_{h-Fi}}{\sum_{i=1}^3 P_{av-Fi} \cdot n_{h-Fi}} = \frac{\sum_{i=1}^3 P_{av-Fi} \cdot n_{h-Fi} \cdot c_{av-Fi}}{\sum_{i=1}^3 P_{av-Fi} \cdot n_{h-Fi}} + \frac{P_{av-F4} \cdot n_{h-F4} \cdot c_{av-F4}}{\sum_{i=1}^3 P_{av-Fi} \cdot n_{h-Fi}} \quad (6)$$

Considering that the first term in the right side of equation (6) is  $c'_{el}$ , it can be

derived as given by:

$$c'_{el} = \frac{c_{el} \sum_{i=1}^4 P_{av\_Fi} \cdot n_{h\_Fi} - P_{av\_F4} \cdot n_{h\_F4} \cdot c_{av\_F4}}{\sum_{i=1}^3 P_{av\_Fi} \cdot n_{h\_Fi}} \quad (7)$$

Finally, from the analysis of Fig. 1, the following assumption can be done:  $P_{av\_F1} \cong P_{av\_F4} \cong P_{av\_F3} \cong P_{av\_F4}$  (i.e. the average power is quite constant along the years). Using this assumption equation (7) can be simplified in the following way:

$$c'_{el} \cong \frac{c_{el} \cdot \sum_{i=1}^4 n_{h\_Fi} - n_{h\_F4} \cdot c_{av\_F4}}{\sum_{i=1}^3 n_{h\_Fi}} \quad (8)$$

It is worth noting that  $c'_{el}$  can be calculated assuming that  $c_{av\_F4}$  is the one imposed by the local distributor (which is an available data).

### 3 Thermal recovery layout

CHP is widely applied to the civil sector where the thermal energy is often recovered by producing water heating or by hot water for the heating system. In the application of this paper the CHP is used to produce steam by means of the thermal recovery layout represented in Fig. 5. There are two levels: the first

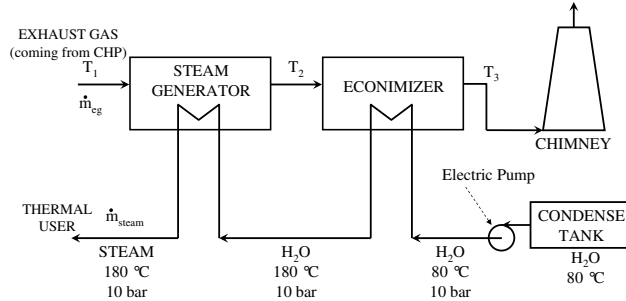

Figure 5: Thermal recovery layout for steam production

one is inside the *steam generator* where the high temperature exhaust gases are used to produce steam at  $180^\circ\text{C}$  and  $10\text{ bar}$  (starting from superheated water at  $180^\circ\text{C}$  and  $10\text{ bar}$ ). The second level employs the exhaust gases coming from the steam generator in the *economizer* in order to heat water from  $80^\circ\text{C}$  to  $180^\circ\text{C}$ . Observing that the steam circuit is supplied by the *condense tank*, it is possible to understand that the condensed water has to be pressurized at the required pressure of  $10\text{ bar}$  by means of an electric pump.

#### 3.1 Technologies

Combined heat and electrical power production is offered by different technologies, therefore it is important to choose the best technology with reference to

the user energy requirements. In this paper two different CHP technologies are analyzed:

- Internal Combustion Engine (ICE)
- Gas Turbine (GT)

### 3.2 Evaluation of the maximum steam flow

For the economical analysis the value of the maximum steam flow which the CHP is able to generate represents an important data. Such CHP performance can be evaluated from the data sheet information. With reference to Fig. 5 it is possible to evaluate the theoretical heat power flow between the exhaust gas and the steam circuit with the following equation:

$$P_{lim} = \dot{m}_{eg} \cdot c_{pg} \cdot (t_1 - t_{steam}) \quad (9)$$

$t_{steam}$  is the temperature of the steam that has to be produced. In this application  $t_{steam}$  is equal to  $180^\circ C$ .

In (9),  $\dot{m}_{eg}$  and  $t_1$  are available in the data sheet of the machine and  $c_{pg}$  is the specific heat of the exhaust gas at constant pressure. In a realistic case the maximum power achievable can reach 90% of the theoretical value:

$$P_{max_{evap}} = \alpha \cdot P_{lim} \quad (10)$$

with  $\alpha = 0.9$ .

From this value it is possible to derive all the other parameters represented in Fig. 5:

$$\dot{m}_{steam} = P_{max_{evap}} / (h_{gas} - h_{liquid}) \quad (11)$$

$$t_2 = t_1 - P_{max_{evap}} / (\dot{m}_{eg} \cdot c_{pg}) \quad (12)$$

$$P_{econ} = \dot{m}_{steam} \cdot (h_{180^\circ C} - h_{80^\circ C}) \quad (13)$$

$$t_3 = t_2 - P_{econ} / (\dot{m}_{eg} \cdot c_{pg}) \quad (14)$$

$$P_{rec_{tot}} = \dot{m}_{eg} \cdot c_{pg} \cdot (t_1 - t_3) \quad (15)$$

In the end, by the equation (11), the maximum steam flow can be calculated and by (15) the total power recovered is determined. These values are important in the economical analysis and in particular in the evaluation of the economical thermal benefits (section 4.2).

## 4 Economical analysis - methodology

In this paragraph the methodology for the calculation of the necessary input data of a CHP investment analysis will be explained. First of all, for the evaluation of the investment the following indicators have been used:

*Net Present Value*, eq. (16): it represents the net total profit during the life of the project, i.e. the difference between the operational profit and the total amount of expenses.

$$NPV = -I_0 + \sum_{i=1}^N \frac{CF_i}{(1+d)^i} \quad (16)$$

*Discounted PayBack Period* (DPBP), eq. (17): it represents the period of time required to refund the initial capital plus the interest that could be received from an alternative investment of this capital.

$$NPV \Big|_{N=DPBP} = 0 \Rightarrow \quad (17)$$

*Benefit to Cost Ratio* (BCR), eq. (18): it is defined as the ratio between the total profit and the total cost of the Project during its lifecycle. The following relation gives a simplified definition:

$$BCR = 1 + \frac{NPV}{I_0} \quad (18)$$

Of course the investment is profitable if BCR is higher than one.

In order to evaluate these three indicators, the annual economic balance of the user is necessary. In this context the economic balance derives from both electrical and thermal balance.

Before starting this important step, the CHP management have to be clearly defined. As already said the CHP will be turned off during the off-peak time bands (F4) because, due to the low energy prices, the selfproduction becomes not economically convenient [3, 16]. Moreover, during the remaining time bands (F1, F2 and F3) the CHP is supposed to work at rated power.

#### 4.1 Electrical energy balance

The aim of the electrical energy balance is the calculation of the annual savings and profits related to the electrical energy flows of the whole system. The prices of the electrical energy are related to the time bands which are hourly defined, therefore, the electrical energy balance have to be done over one year with one hour of maximum time step ( $\Delta t$ ). In Fig. 6 an example of the electrical load and generation profile during one day is represented. The time bands are indicated below the x-axis. The values are expressed in “per unit” and they are not relative to the user under analysis because here the methodology has to be pointed out and the data in Fig. 6 represents in one day all the possible cases which can be found in the electrical energy balance of one year.

Starting from the left side of Fig. 6, the day has to be analyzed hour by hour. Three different cases can be found:

- **Case1:** CHP turned off



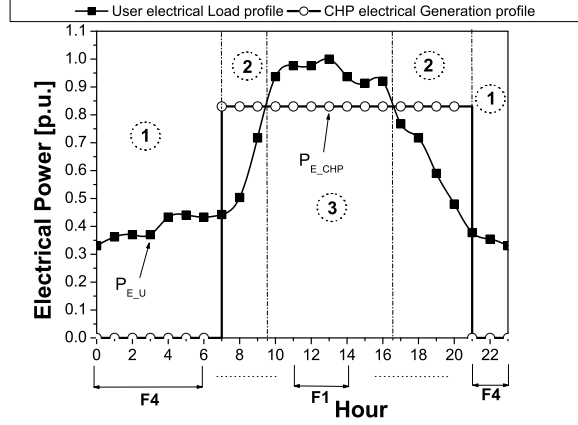

Figure 6: Electrical balance with samples of an electrical demand profile and CHP production profile

- **Case2:** CHP turned on with load profile lower than the generation profile
- **Case3:** CHP turned on with load profile higher than the generation profile

In *Case 1* all the energy required by the load has to be bought. It has to be stressed that the annual money related to this quote of energy is not important for the economical analysis which compares the situation where no investment is done and the situation where the investment is done. It is easy to understand that this quote of money is present in both situations (with or without CHP), therefore it disappears in the comparison.

In *Case 2* the energy required by the load corresponds to the selfconsumed energy and the area between the load profile and the generation profile is the energy sold to the utility. The energy produced by a CHP unit can be sold to the Utility by the *Single Buyer* (SB) prices. SB is a figure of the free energy market which has to assure to the final user the supply of energy at good prices and reliability. SB has to buy the electrical energy on the market and then sell it to the local distributors. In this last operation the SB prices are used. The SB prices are also related to the time bands.

The money related to the annual selfconsumption and the annual sold energy within case 2 can be calculated with the following sums over one year:

$$\text{€}_{E_{SC}}^{case2} = \sum_i^{year} P_{E,U_i} \cdot \Delta t_i^{case2} \cdot c_{el} \quad (19)$$

$$\text{€}_{E_S}^{case2} = \sum_i^{year} (P_{E,CHP_i} - P_{E,U_i}) \cdot \Delta t_i^{case2} \cdot c_{SB-Fi} \quad (20)$$

It is worth noting that the first sum takes into account the average electrical energy price  $c_{el}$  because usually only this price is known. If the price of the electrical energy bought by the users in the different ranges are known, equation (19) can be modified in the following way:

$$\epsilon_{ESC}^{case2} = \sum_i^{year} P_{E-U_i} \cdot \Delta t_i^{case2} \cdot c_{av-Fi} \quad (21)$$

In Case 3 the energy generated by the CHP correspond to the selfconsumption and the area between the two profiles is the energy bought by the user. Also in this case the energy bought is not useful in the analysis for the same reason explained in case 1. It is possible to calculate the money related to the annual selfconsumption in case 3 with the following sum over one year:

$$\epsilon_{ESC}^{case3} = \sum_i^{year} P_{E-CHP_i} \cdot \Delta t_i^{case3} \cdot c_{el} \quad (22)$$

In conclusion the total annual savings due to selfconsumption of electrical energy ( $\epsilon_{ESC}$ ) and the total annual profits due to the selling of energy ( $\epsilon_{Es}$ ) is defined by:

$$\epsilon_{ESC} = \epsilon_{ESC}^{case2} + \epsilon_{ESC}^{case3} \quad (23)$$

$$\epsilon_{Es} = \epsilon_{Es}^{case2} \quad (24)$$

## 4.2 Thermal energy balance

In this paragraph the methodology which allows to calculate the *savings* concerning the thermal aspects will be shown.

The thermal energy balance is done performing the balance of the four typical days, although only two typical days are taken into account because on weekend days the CHP unit is turned off. Afterwards the result of each typical day is multiplied for the number of equal days in the year. With reference to Fig. 7, where load and generation profiles of the typical summer week day are represented, the thermal balance can lead to two different cases:

1. User steam flow demand higher than the maximum production steam flow
2. User steam flow demand lower than the maximum production steam flow

The F4 hours have been excluded from the thermal balance because the CHP is turned off, hence, their contribution disappear in the economical analysis (in analogy with the electrical energy balance).

**Case 1:** when the user demand is higher than the maximum steam production the heat power recovered is already calculated through (15), therefore the recovered energy can be evaluated knowing the number of hours of this working configuration ( $n_h^{(1)}$ ). It has to be stressed that the savings in terms of primary

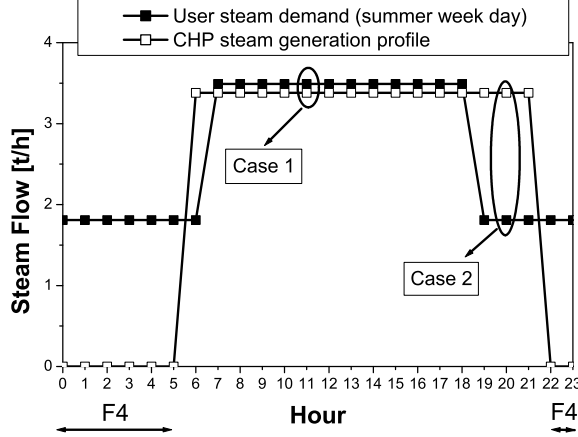

Figure 7: Thermal Balance: load and generation profile for the typical summer week day

energy has to be calculated, i.e., with reference to Fig. 2, producing an amount of steam the energy savings due to the avoided combustion of natural gas have to be evaluated. Assuming the performances of boiler and indirect evaporator as  $\eta_b$  (which in this case is supposed to be equal to 0.9 in both system) the right energy is obtained as given by:

$$E^{(1)} = \frac{P_{rec_{tot}^{(1)}} \cdot n_h^{(1)}}{\eta_b^2} \quad (25)$$

**Case 2:** when the user demand is lower than the maximum steam production, only the user demand flow ( $\dot{m}_{ud}$ ) can be recovered. Therefore, using  $\dot{m}_{steam} = \dot{m}_{ud}$  in (11) and (13) the heat power relative to steam generator and economizer can be derived. Afterwards, using (12), (14) and (15) the recovered heat power relative to the “Case 2” is determined. Finally, the energy savings can be calculated like in the previous case:

$$E^{(2)} = \frac{P_{rec_{tot}^{(2)}} \cdot n_h^{(2)}}{0.9^2} \quad (26)$$

In conclusion, the total energy saving is  $E_{tot} = E^{(1)} + E^{(2)}$ . Therefore, knowing the average natural gas price ( $c_{ng}$ ) in [ $\text{€}/\text{m}^3$ ] (section 4.3), the total saving is:

$$\text{€ savings} = \frac{E_{tot} \cdot c_{ng}}{LHV} \quad (27)$$

### 4.3 Operational costs

The *operational costs* are related to the CHP fuel and maintenance. The data sheet of the machine gives the consumption in terms of  $m^3/h$ . The number of working hours in a year is well known because the management of the machine, as already said, is imposed. Therefore, in order to calculate the annual fuel cost, it is necessary to know the price of the natural gas. The AEEG define the fuel prices relative to the some energy range of consumption. It should be noted that this is the base price (without taxes) and it is different for every region, Table 3 shows the prices relative to this application.

Concerning fuel taxes, since the cogeneration allows a significant primary energy saving the CHP fuel is subject to tax reduction as incentive. The Italian law 26<sup>th</sup> October 1995 says that in a CHP unit a quote of the fuel used for the electrical energy production or selfproduction has a tax reduction, see Table 4.

The quote of fuel with tax reduction can be derived by means of equation (28). It has to be stressed that the value 0.25 in (28) is imposed by the Italian law which derives from the assumption of an electrical efficiency of the CHP of about 42%. Therefore, in case of actual electrical efficiency lower than 42% the quote of fuel with tax reduction will be lower than the total burned fuel. On the contrary, if the actual electrical efficiency is higher than 42% all the used fuel has the incentive as summarized in Fig. 8.

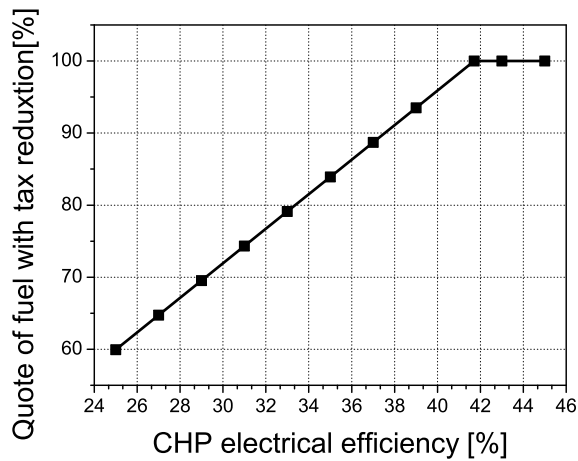

Figure 8: Relation between fuel with tax reduction and CHP electrical efficiency

In order to calculate the fuel cost with tax reduction it is a good thing to evaluate the average value of the fuel base prices in Table 3 weighed on the consumption. It has to be stressed that also for a CHP unit of a “little” size (i.e. 500 kW), most of the consumption is in the last range, therefore the average prices are closer to the last range price rather than to the first one.

Table 3: Fuel cost - Distribution and *Natural Gas* prices

| Consumption range [MJ] |          | Distribution Price | Natural gas price |
|------------------------|----------|--------------------|-------------------|
| from                   | to       | [€/m3]             | [€/m3]            |
| 1                      | 20000    | 0.057354           | 0.290604          |
| 20001                  | 60000    | 0.05652            | 0.28977           |
| 60001                  | 200000   | 0.054494           | 0.287744          |
| 200001                 | 1000000  | 0.049053           | 0.282303          |
| 1000001                | 4000000  | 0.016602           | 0.249852          |
| 4000001                | 8000000  | 0.010128           | 0.243378          |
| 8000001                | $\infty$ | 0.006117           | 0.239367          |

Table 4: Fuel Taxes with reference to type of use

| Type of Fuel use                    | Consumption tax | Regional Tax |
|-------------------------------------|-----------------|--------------|
|                                     | [€/m3]          | [€/m3]       |
| Generic                             | 17,3307         | 2,5800       |
| Industrial                          | 1,2498          | 0,6249       |
| Selfproduction of electrical energy | 0.01348         | 0            |
| Production of electrical energy     | 0.04493         | 0            |

Knowing the base price, the natural gas price with tax reduction ( $c'_{ng}$ ) can be derived by adding the right taxes of Table 4. In conclusion, if the CHP has an electrical efficiency higher than 42%, all the fuel is subjected to tax reduction but, since this electrical efficiency is quite uncommon for the classical application, the operational costs have to be calculated in the following way for most of the CHPs:

$$v'_{ng} = 0.25 \cdot E_{el_{tot}} \quad (28)$$

$$\epsilon_{ng} = c'_{ng} \cdot v'_{ng} + c_{ng} \cdot (v_{ng} - v'_{ng}) \quad (29)$$

#### 4.4 Maintenance and initial investment

The maintenance aspect and the initial capital investment data are taken from reference [17] where the state of art of the technologies for cogeneration purposes are summarized. The CHP cost is proportional to the rated power of the machine while the maintenance is linked to working hours of cogeneration

system (or the CHP produced energy). Table 5 summarizes the values which have been used in this paper.

Table 5: Investment and maintenance costs for CHP system

|                           |           |
|---------------------------|-----------|
| ICE investment cost       | 900 €/kW  |
| Turbo Gas investment cost | 1350 €/kW |
| Maintenance (ICE and GT)  | 1 €/c/kWh |

#### 4.5 Amortization

The *instrumental objects* which are “factors of production” are subjected to the wear and tear. This justifies the amortization procedure which determines the annual capital quote representing the instrumental object loss of value, this quote has to be stored for a number of years ( $n$ ) which depends on the instrumental object typology. It has to be stressed that the amortization annual quote is not subjected to taxes. Hence, during the first  $n$  years of the investment life an economical benefit can be derived from the amortization procedure.

For a CHP the number of years is equal to ten ( $n = 10$ ), therefore the annual amortization quote is:

$$a_q = \frac{I_0}{n} = \frac{I_0}{10} \quad (30)$$

## 5 Results

In order to do a good comparison three different CHP units have been analyzed:

ICE 1000 kW: in this case there will be a full covering of the electrical demand and a partial covering of the thermal steam demand.

ICE 3000 kW: in this case there will be a full covering of the electrical demand with a high selling of electrical energy in the time bands F1, F2 and F3. Moreover, the thermal steam demand is almost covered.

GT 1000 kW: in this case there will be a full covering of the electrical demand and the thermal steam demand is almost covered.

Furthermore, for all the CHP units three different economical analyses have been performed. The first one refers to the case where rough data are available for electrical energy prices ( $c_{el}$ ) and cogeneration do not take incentive ( $c_{ng}$ ). The second one introduces tax reduction on the CHP fuel ( $c'_{ng}$ ). The third one is referred to a case where more detailed data about electrical energy prices are available. In this case the right prices for savings related to electrical selfconsumption can be used ( $c'_{el}$ ).

Table 6 summarizes the main parameters of the three economical analysis.

Looking at Table 6 it can be also seen that among the different analyses there is only one changing of parameter, this means that finally, also a sensitivity analysis within the three scenarios will be presented.

Table 6: Economical analyses - summary of the main parameters

|                                    | Econ.<br>analysis 1 | Econ.<br>analysis 2 | Econ.<br>analysis 3 |
|------------------------------------|---------------------|---------------------|---------------------|
| Electrical energy<br>Selling price | SB<br>prices        | SB<br>prices        | SB<br>prices        |
| User price<br>(Selfcons. saving)   | $c_{el}$            | $c_{el}$            | $c'_{el}$           |
| Natural Gas<br>price               | $c_{ng}$            | $c'_{ng}$           | $c'_{ng}$           |

## 5.1 CHP comparison

In Fig. 9, 10 and 11 the economical analysis results are shown.

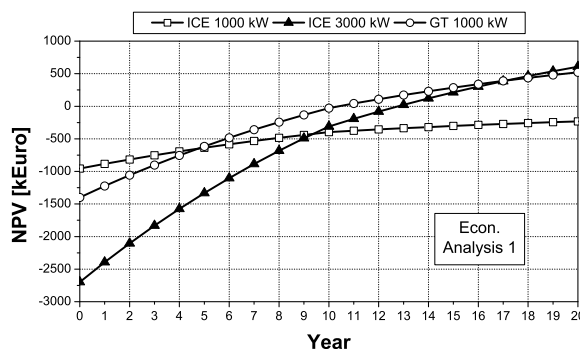

Figure 9: Economical analysis 1 - NPV during 20 years for the three CHP systems

Table 7: Economical analysis 1 - Summary of the economical indicators

| CHP      | $I_0$<br>[€] | DPBP<br>[years] | NPV<br>[€] | BCR  |
|----------|--------------|-----------------|------------|------|
| ICE 1000 | 960000       | > 20            | -231691    | 0.76 |
| ICE 3000 | 2700000      | 12.53           | 607509     | 1.23 |
| GT 1000  | 1400000      | 10.6            | 521449     | 1.37 |

The results of the first economical analysis put in evidence that ICE 1000 is not a convenient investment because its DPBP is higher than 20 years. Also

the ICE 3000 investment is questionable because the DPBP is relatively high. Concerning this analysis the GT 1000 has the lowest DPBP but also its final NPV is lower than the ICE 300 NPV. Looking at the BCR indicator we have the confirmation that ICE 1000 is not a profitable investment.

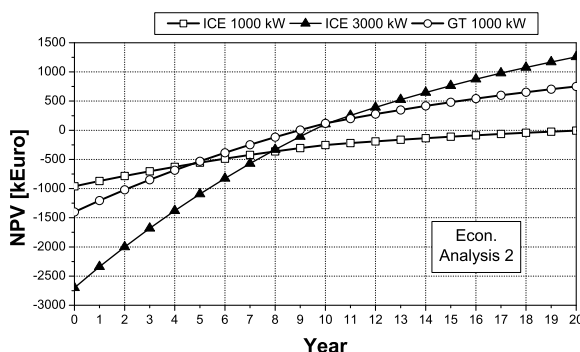

Figure 10: Economical analysis 2 - NPV during 20 years for the three CHP systems

Table 8: Economical analysis 2 - Summary of the economical indicators

| CHP      | $I_0$<br>[€] | DPBP<br>[years] | NPV<br>[€] | BCR  |
|----------|--------------|-----------------|------------|------|
| ICE 1000 | 960000       | $\approx 20$    | 4839       | 1.01 |
| ICE 3000 | 2700000      | 9.69            | 1257038    | 1.47 |
| GT 1000  | 1400000      | 9.14            | 751660     | 1.54 |

The results of the second economical analysis agree with the first one regarding ICE 1000 because, in this case, its DPBP is near to 20 years. Instead ICE 3000 and GT 1000 has a quite similar value of DPBP therefore the investors have to decide the best investment with reference to other indicators. For instance, the ICE 3000 NPV at 20 years is almost two times the GT 1000 NPV. Of course the same observation is also true concerning the initial investment cost of the machines. BCR indicator shows that the GT 1000 is the solution with higher profits with respect to the initial investment.

The results of the third economical analysis point out that the two ICES have similar DPBP. The initial investment cost and the NPV of the ICE 3000 are about three times the relative ICE 1000 values. The GT 1000 has the lowest DPBP and a NPV included between the values of the other two CHPs.

Finally, it is possible to observe that in all the analysis the higher BCR value is reached by GT 1000. Therefore, all the analysis agree on this result: GT 1000



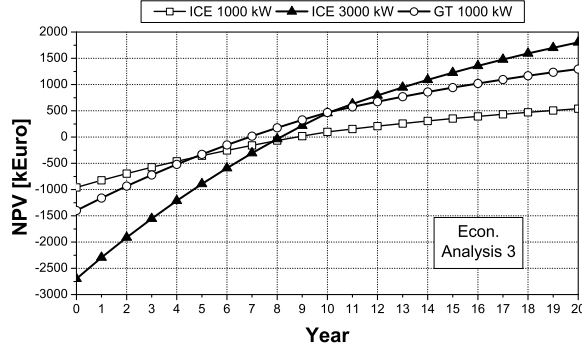

Figure 11: Economical analysis 3 - NPV during 20 years for the three CHP systems

Table 9: Economical analysis 3 - Summary of the economical indicators

| CHP      | $I_0$<br>[€] | DPBP<br>[years] | NPV<br>[€] | BCR  |
|----------|--------------|-----------------|------------|------|
| ICE 1000 | 960000       | 8.95            | 540570     | 1.56 |
| ICE 3000 | 2700000      | 8.27            | 1802616    | 1.67 |
| GT 1000  | 1400000      | 6.98            | 1296033    | 1.88 |

is the solution with higher profits with respect to the initial investment.

## 5.2 Sensitivity analysis

In Fig. 12, 13 and 14 the sensitivity analysis results are shown. With reference to Fig. 12 it is possible to note that the parameter with more influence on the final result is the price of the electrical energy bought by the user. The NPV final value depends on the annual CF which is calculated as total profits minus total costs. The tax reduction of natural gas prices decrease the operational costs, instead, increasing the average energy price bought by the user also the total savings, i.e. profits, increase. This means that tax reduction on natural gas prices reduce the total costs less than the rising of the electrical energy prices increase the total profits.

With reference to Fig. 13 it is possible to say that the variation of the cost of natural gas and the price of electrical energy bought by the user have similar effects on the final economical results. The higher consumption of the ICE 3000 make the final results more sensible to the fuel cost. In this condition a high quote of total profit is derived by the electrical energy sold to the utility. Therefore this system is sensible to the variation of single buyer prices. This

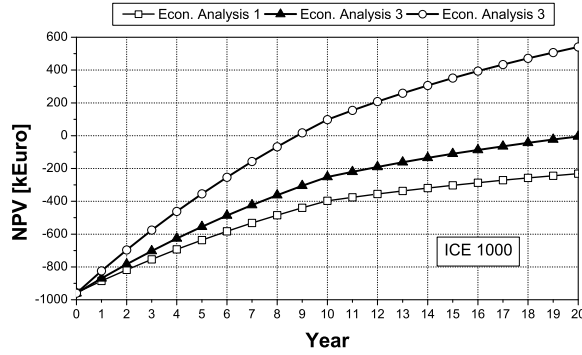

Figure 12: Sensitivity analysis 1 - ICE 1000 kW: NPV during 20 years in the three different analyses

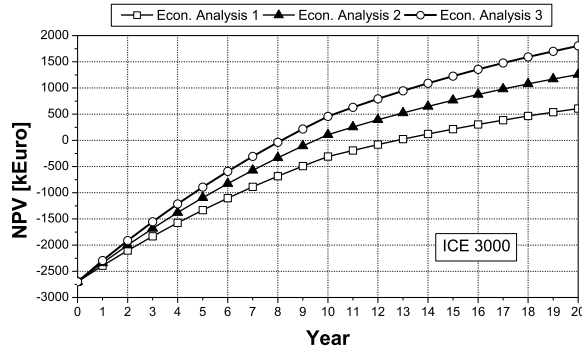

Figure 13: Sensitivity analysis 2 - ICE 3000 kW: NPV during 20 years in the three different analyses

variation has not been taken into account because the single buyer prices are always well defined and available.

With reference to Fig. 14 it is possible to note that the parameter with more influence on the final result is the price of the electrical energy bought by the user. The same observation of ICE 1000 can be done.

Finally, looking at the three sensitive analysis, it is possible to note that the NPV increment related to the variation of the electrical energy price from  $c_{el}$  to  $c'_{el}$  is equal for each CHP (about 500 k€). This is a predictable result because, as already said, this variation increase the money saving due to electrical self-consumption. It has to be stressed that all the CHP are able to cover the user electrical demand, therefore the energy saving is equal in all the three cases as

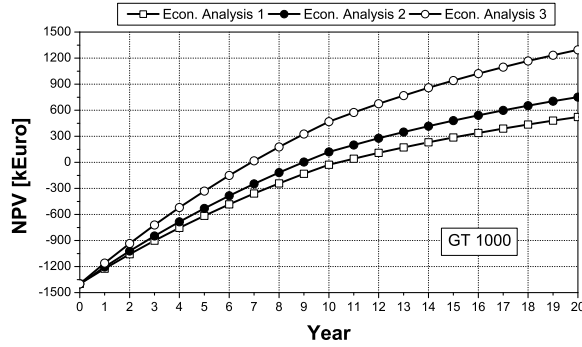

Figure 14: Sensitivity analysis 3 - Gt 1000 kW: NPV during 20 years in the three different analyses

well as the money related to this saving.

## 6 Conclusion

In cogeneration field the choice of the best investment is not a simple task. Moreover the words “best investment” can have different meaning if the problem is seen from different points of view (i.e. investor point of view, CHP manager point of view, etc...). Many economical parameters can be evaluated in order to find the solution that best fits all these points of view. In this paper one case study has been treated in order to prove that economical parameters can reach very different values with reference to the variation of the input data and inaccurate assessment of the economical parameters could lead to a wrong system choice.

In the present case study the most accurate analysis is the third one. By mean of its results the best choice could be the GT because it has the lowest DPBP and the highest BCR. It is worth noting that, before taking the final decision, also a technologies comparison has to be done. In fact gas turbines of about 1 MW of size have not good availability in the market because there are few manufacturers which develop GTs of this size. Then GT performances tightly depend on the environmental parameter like external temperature. On the contrary ICEs have good availability for both 1MW and 3 MW of size, moreover their performances are quite constant with reference to the external environmental parameters. These considerations bring us in the direction of the ICEs because this technology is more consolidated and implies a lower risk in the investment. Finally the best ICE size has to be chosen. This decision is very subjective because the DPBT is similar in both cases (8.95 years for ICE 1000 against 8.27 years of ICE 3000). From BCR parameters we can say that

ICE 3000 is a more profitable investment but it is also true that, in this case, ICE 3000 has a triple initial cost. Finally, although the best CHP is ICE 3000, this choice depends on the investor economical capability.

In conclusion, the key point of this work is to present a complete methodology which allows to reach good results starting from data usually available in actual cases. All input data have been described and their application in the economical analysis has been deeply explained. We believe that the economical analysis has to be based on the load profile of the consumer who will use the CHP energy because the aggregate consumptions can lead to a design of a system which does not match the hourly energy needs of the user. In this case the high thermal energy losses will decrease the overall efficiency making senseless the CHP operation. Hence, the predicted economic results will not be reached.

Moreover the attention is focused on the steam production. This is not a common application therefore is not so easy to find in CHP data sheets the rated value of the producible steam. Another key point of this paper is to suggest a methodology for evaluating the steam production both for GTs and ICEs starting from their data sheet parameters.

## References

- [1] CONCERTO web site: <http://www.concertoplus.eu> [2008-04-23].
- [2] POLYCITY official website: <http://www.polycity.net> [2008-04-23].
- [3] G. G. Maidment, X. Zhao, and S. B. Riffat. Combined cooling and heating using a gas engine in a supermarket. *Applied Energy*, 68:321 – 335, 2001.
- [4] T. Kosugi, K. Tokimatsu, and W. Zhou. An economic analysis of a clean-development mechanism project: a case introducing a natural gas-fired combined heat-and-power facility in a chinese industrial area. *Applied Energy*, 80:197 – 212, 2005.
- [5] K. H. Khan, M. G. Rasul, and M. M. K. Khan. Energy conservation in buildings: cogeneration and cogeneration coupled with thermal-energy storage. *Applied Energy*, 77:15 – 34, 2004.
- [6] E. Cardona and A. Piacentino. Optimal design of chcp plants in the civil sector by thermoeconomics. *Applied Energy*, 84:729 – 748, 2007.
- [7] P. Arcuri, G. Florio, and P. Fragiaco. A mixed integer programming model for optimal design of trigeneration in a hospital complex. *Energy*, 32:1430 – 1447, 2007.
- [8] M. Medrano, J. Brouwer, V. McDonnel, J. Mauzey, and S. Samuelson. Integration of distributed generation systems into generic types of commercial buildings in california. *Energy and Buildings*, 40:537 – 548, 2008.

- [9] S.A. Farghal, R.M. El-Dewieny, and A.M. Riad. Economic justification of cogeneration systems for industrial steam users and utility systems. In *Generation, Transmission and Distribution [see also IEE Proceedings-Generation, Transmission and Distribution]*, *IEE Proceedings C*, volume 136, pages 100–107, March 1989.
- [10] F.E. Karagiannis. Central cogeneration units in athens-an economical approach. In *Electrotechnical Conference, 2000. MELECON 2000. 10th Mediterranean*, volume 3, pages 1032–1035vol.3, 29-31 May 2000.
- [11] A. Shah and N. Krishnan. Life cycle evaluation of combined heat and power alternatives in data centers. In *Electronics and the Environment, 2005. Proceedings of the 2005 IEEE International Symposium on*, pages 19–24, 16-19 May 2005.
- [12] J. F. Kreider and A. Rabi. *Heating and Cooling in buildings: Design for efficiency*. McGraw-Hill, 1994.
- [13] T.J. Ratajczak and Zuyi Li. Applications and economic analysis of a high reward, low risk cogeneration system. In *Power Engineering Society General Meeting, 2005. IEEE*, pages 592–598Vol.1, 12-16 June 2005.
- [14] R. Jablko, C. Saniter, R. Hanitsch, and S. Holler. Technical and economical comparison of micro chp systems. In *Future Power Systems, 2005 International Conference on*, page 6pp., 16-18 Nov. 2005.
- [15] G. Chicco and P. Mancarella. From cogeneration to trigeneration: profitable alternatives in a competitive market. *Energy Conversion, IEEE Transactions on*, 21(1):265–272, March 2006.
- [16] A. Canova, C. Cavallero, F. Freschi, L. Giaccone, M. Repetto, and M Tartaglia. Comparative economical analysis of a small scale trigenerative plant: a case study. *to appear in IAS Magazine*, 2009.
- [17] M. Verga. Comparison and positioning of the different technologies for distribute generation. proceedings of the International Conference "Micro-Polygeneration of Energy", November 2005.