

A Media Converter Prototype for 10-Mb/s Ethernet Transmission Over 425 m of Large-Core Step-Index Polymer Optical Fiber

*Original*

A Media Converter Prototype for 10-Mb/s Ethernet Transmission Over 425 m of Large-Core Step-Index Polymer Optical Fiber / D., Cardenas; A., Nespola; P., Spalla; S., Abrate; Gaudino, Roberto. - In: JOURNAL OF LIGHTWAVE TECHNOLOGY. - ISSN 0733-8724. - 24, n.,12:(2006), pp. 4946-4952. [10.1109/JLT.2006.884566]

*Availability:*

This version is available at: 11583/1535742 since:

*Publisher:*

IEEE

*Published*

DOI:10.1109/JLT.2006.884566

*Terms of use:*

This article is made available under terms and conditions as specified in the corresponding bibliographic description in the repository

*Publisher copyright*

(Article begins on next page)

# A Media Converter Prototype for 10-Mb/s Ethernet Transmission Over 425 m of Large-Core Step-Index Polymer Optical Fiber

Daniel Cárdenas, Antonino Nespola, Pietro Spalla, Silvio Abrate, *Member, IEEE*,  
and Roberto Gaudino, *Member, IEEE*

**Abstract**—A prototype media converter for transmitting 10-Mb/s Ethernet/IEEE 802.3 data over a large-core (1 mm) step-index polymer optical fiber (SI-POF) is presented. The system is demonstrated over a record maximum distance of 425 m, which greatly outperforms, in terms of reach, previously published results and commercially available systems, which are usually limited to approximately 100 m. This extended reach allows to envision new applications of SI-POF such as in the last part of access networks, edge networks, in-house and in-building networks, industrial automation, airplane and ship cabling, and all areas where the resilience and ease of installation of SI-POF can be a fundamental advantage.

**Index Terms**—Ethernet, forward error correction (FEC), media converter, polymer optical fiber (POF).

## I. INTRODUCTION

THE MECHANICAL and optical characteristics of a 1-mm PolyMethylMetaAcrylate step-index polymer optical fiber (PMMA-SI-POF), such as stress resilience, low bending radius, low bending losses, ease of connection and installation, which are all due to the large fiber core and high numerical aperture (NA), would make this type of fiber an ideal candidate for low-cost connection in a wide area of short- and medium-reach applications. All of these mechanical advantages are coupled with two main drawbacks: high attenuation and strong multimodality [1]. These two characteristics have so far limited the use of PMMA-SI-POF in short-reach and low-bit-rate applications (typically less than 100 Mb/s and less than 100 m). In fact, today, the automotive sector is the market in which POF is most widely used: More than eight million cars use this fiber for their infotainment network [2], [3]. However, PMMA-SI-POF has been proposed for other areas, such as in-house and in-building networks, and edge networks, i.e., the very last part of access networks [7].

The most performing commercial transceivers for PMMA-SI-POF today are mostly focused on the Ethernet standard and

are able to reach 200 m at 10 Mb/s or 100 m at 100 Mb/s [6]. An interesting field of research for POF today is also the IEEE 1394 S200-S400 Firewire standard [16] over distances of up to 50 m.

The focus of this paper is the experimental demonstration of a PMMA-SI-POF media converter for fully compliant 10-Mb/s Ethernet transmission over an extended distance, covering more than 400 m with a suitable system margin. Besides being, to the best of our knowledge, a record transmission result on this type of fiber, we believe that this extended reach can encourage the use of PMMA-SI-POF in new areas, such as data transfer in large industrial environments, in-house and in-building networks, aircrafts/ships cabling, and edge networks. For instance, the target specifications for the system we projected and hereafter will describe have been given us by the main Italian fiber-to-the-home (FTTH) operator. They are currently using an access architecture where the edge part toward the final user is based on 10-Mb/s optical Ethernet links over multimode glass fibers, and from the statistics of their current subscribers, it emerges that 90% of their edge links from the shared switch in the building basement toward the apartments are within a fiber length of 400 m. In this scenario, ease of installation is key; thus, a large-core POF may attract significant interest. In fact, the same FTTH operator previously mentioned estimates that no more than two customer connections a day can be activated by an average installer team because of difficulties in handling glass fibers in household environments. Details on the potential use of our media converter in this scenario were given in [15].

The main goal of this paper is to demonstrate that large-core PMMA-SI-POF can actually be used over a significantly longer distance than what it is commonly perceived. While this paper focuses on a relatively low bit rate of 10 Mb/s, we mention that our team is currently coordinating a new European research project called “POF-ALL” [17], where an upgrade of the ideas presented in this paper to 100 Mb/s (and even 1 Gb/s over a shorter distance) will be investigated from both technical and application points of view.

The media converter presented in this paper is based on a proprietary transmission protocol using nonreturn to zero (NRZ) continuous transmission [12], 8B/10B [4], and Reed–Solomon (RS) forward error correction (FEC) [8] coding and high-performance clock and data recovery. The protocol is demonstrated on a commercial field-programmable gate array (FPGA) board. The developed high-performance transmission protocol, together with careful selection of commercial optoelectronic components, allows error-free transmission over a distance of

Manuscript received February 3, 2006; revised July 21, 2006. This work was supported in part by the EU FP6 NoE e-Photon/ONe WP3.

D. Cárdenas and R. Gaudino are with Optical Communications Group, Dipartimento di Elettronica, Politecnico di Torino, 10129 Torino, Italy (e-mail: daniel.cardenas@polito.it; roberto.gaudino@polito.it).

A. Nespola and S. Abrate are with the Istituto Superiore Mario Boella, 10138 Torino, Italy (e-mail: nespola@ismb.it; abrate@ismb.it).

P. Spalla was with Istituto Superiore Mario Boella, 10138 Torino, Italy. He is now with Torino Wireless, 10129 Torino, Italy (e-mail: pietro.spalla@torinowireless.it).

Digital Object Identifier 10.1109/JLT.2006.884566

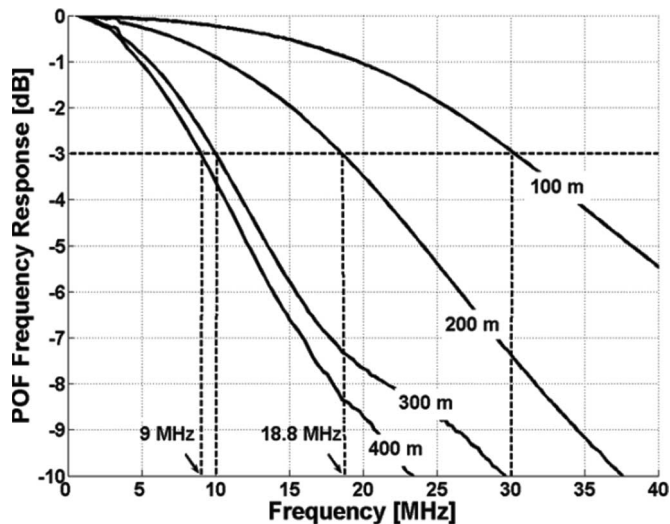

Fig. 1. SI-POF frequency response (electrical-to-electrical) for several link lengths. 3-dB bandwidths are also shown.

425 m. This paper reports the physical-layer techniques that have been introduced in order to achieve this record distance, and it is organized as follows: In Section II, an experimental analysis of the physical limitations in the attenuation and bandwidth imposed by the transmission channel, which includes the PMMA-SI-POF and the transmission/receive optoelectronic components, is presented. This is followed in Section III by a functional description of the proprietary transmission protocol. The system characteristics are shown in Section IV by a set of experimental measurements. In Section V, we analyze the temperature stability of the proposed systems in order to address the often-cited concern about the temperature resilience of PMMA-SI-POF links. Finally, the obtained results are discussed in Section VI.

## II. TRANSMISSION CHANNEL CONSTRAINTS

The two main limitations of PMMA-SI-POF links are low bandwidth and high attenuation [1]. Concerning bandwidth, all measurements available in the literature are, to the best of our knowledge, limited to 150–200 m, with a typical reported value of 30 MHz · 100 m for high-NA PMMA-SI-POF [1], [5], [10]. In Fig. 1, we present, for the first time to our knowledge, bandwidth measurements of the PMMA-SI-POF for distances greater than 200 m and up to 400 m, with the latter value being the reference target distance for our system. All measurements were done using a commercial 1-mm PMMA-SI-POF fiber (provided by Luceat S.p.A) with an NA of about 0.46. For our 400-m target reach, the figure shows that a 3-dB bandwidth of about 9 MHz is available for a 400-m link. This bandwidth poses a very severe limitation for standard 10-Mb/s Ethernet transmission. In fact, the use of Manchester coding [13] required by the standard asks for an available bandwidth close to twice the actual bit rate, i.e., an available bandwidth close to 20 MHz. This explains why in our proprietary protocol, which will be explained later, it was mandatory to change the line code from Manchester to a combination of NRZ and 8B/10B in order to overcome bandwidth limitation while still keeping high transition density and dc balancing.

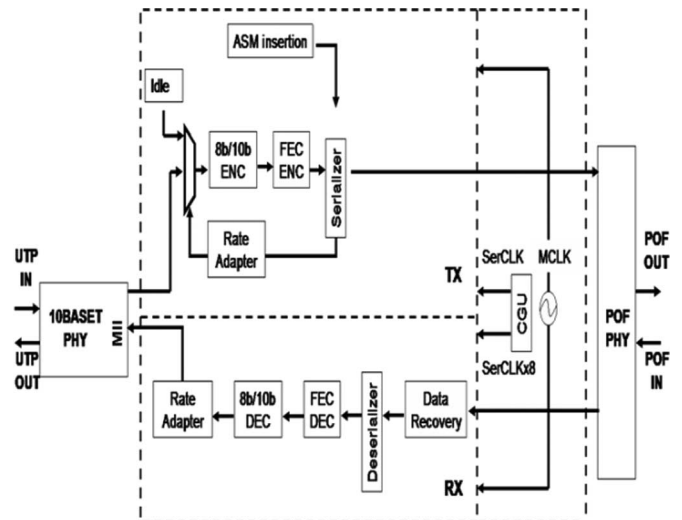

Fig. 2. Media converter system architecture.

Alongside the bandwidth problem, standard PMMA-SI-POF exhibits an attenuation of the order of 0.15 dB/m in the typically used red wavelength region (650 nm) [1]. This high attenuation makes transmission over our 400-m target distance impossible since it would ask for more than the 60-dB power budget. We thus opted for green wavelength transmission (520 nm) [7], where PMMA shows an attenuation minimum of the order of 0.08 dB/m. With this attenuation, we get a more reasonable link total attenuation of approximately 35 dB for our target distance, including one to two connectors. Considering at least a 3-dB system margin, our system should tolerate a fairly high 38-dB power budget, which requires an optimization in the transmitter and receiver design in terms of average launched power and sensitivity. It also explains why FEC coding was introduced in our protocol.

Regarding the optoelectronic part, the proposed system is based on commercial components, i.e., a green LED (Die-Mount) and a photodiode-transimpedance amplifier (Hamamatsu S6468-02). The  $-3$ -dB bandwidth is 35 MHz for the LED (with an optimal driving current) and 25.8 MHz for the photodiode-transimpedance amplifier, while the LED-launched average power is about +1 dBm. The combination of the two optoelectronic elements gives an equivalent cutoff frequency of about 20 MHz, a value that, being significantly higher than the 9 MHz offered by the 400-m POF, does not limit significantly the global available bandwidth.

In conclusion, the proposed 400-m system is bandwidth limited mainly by the fiber, with a global available bandwidth of 9 MHz, and should cope with at least 35 dB of link attenuation and thus, typically, a 38-dB power budget.

## III. MEDIA CONVERTER SYSTEM DESCRIPTION

The media converter is based on two parts, as shown in Fig. 2: 1) an optoelectronic part that interfaces with the POF (indicated as POF-PHY in the figure, indicating with this the “physical” optoelectronic part of the system) and 2) the logical core of the converter, which implements the proprietary protocol. This second part was implemented on a commercial FPGA development

board (XILINX Spartan-3). Our protocol performs a conversion of the incoming Ethernet frames to a new framing model based on the RS-FEC block. This structure has been designed with the following target in mind: improve the physical-layer-transmission performance with respect to standard Ethernet while keeping the digital complexity at a reasonable level by developing an algorithm that can be easily implemented in digital electronics. The key idea is to map the incoming traffic into a synchronous and continuous transmission based on 8B/10B and RS-FEC. We opted for a transmission framing that coincides with a FEC block.

We will describe here each functional element reported in Fig. 2, logically following the signal path from the electrical Ethernet input to the POF at the transmitter side and then in the reverse order at the receiver side.

- 1) *10BASE-T-PHY*: Via a commercial Ethernet PHY chip, which handles the full set of Ethernet physical-layer specification, the Manchester encoded signal is passed to the algorithm core by means of a media independent interface.
- 2) *Rate adaptation*: We decided to force a strictly continuous bit transfer over the PMMA-SI-POF to allow good optimization of clock and data recovery at the receiver side. To this end, due to the fact that the input Ethernet traffic is intrinsically bursty, the rate-adaptation unit inserts properly coded “idle” words in the absence of incoming Ethernet data in order to guarantee a continuous output data stream.
- 3) *DC balancing*: As most optoelectronic transmission systems, our optoelectronic system is ac coupled (i.e., with a zero in the receiver at null frequency) with a low cutoff frequency of about 30 kHz. At the bit rate of our systems (approximately 10 Mb/s), this cut would generate significant baseline wander effects [14] using standard NRZ, unless some proper countermeasure is taken. We thus decided to use 8B/10B line coding [4] that, besides assuring a good dc balanced signal, eases clock recovery because of high transition density. Moreover, 8B/10B adds monitoring features, due to the availability of reserved control words (called K-characters in the 8B/10B standard). In our protocol, we have used a subset of the K-characters for implementing a dedicated framing. In particular, a “frame” in our protocol coincides with a FEC block (will be discussed later in the text) and is delimited by four K28.5 characters that act as an “attached sync mark (ASM).” Moreover, we have used K27.7 and K23.7 K-characters [4] for implementing the previously mentioned rate adaptation by using these two characters as “idle” words. As a result of what has been described until now, the Ethernet input data are mapped on a new framing structure.

The use of 8B/10B comes, anyway, together with the well-known 25% overhead. We observe that this 25% overhead is much smaller than the 100% bandwidth overhead required by conventional Manchester encoding.

- 4) *FEC*: In order to increase overall system sensitivity, our protocol uses RS FEC [5] to increase the power budget. To match the 10-bit words at the output of the 8B/10B

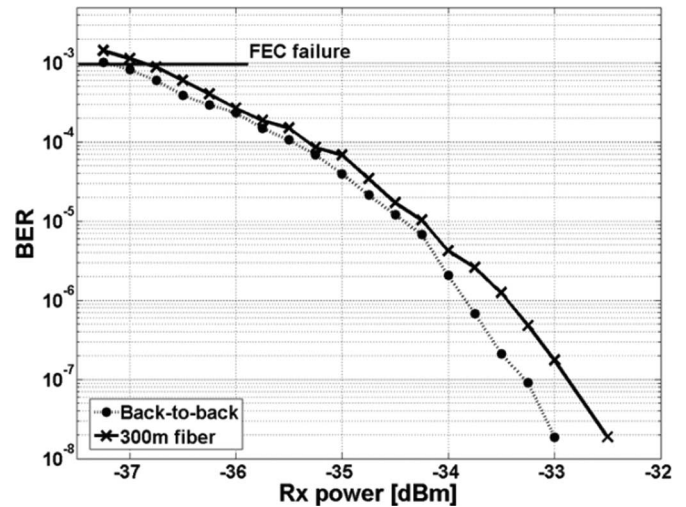
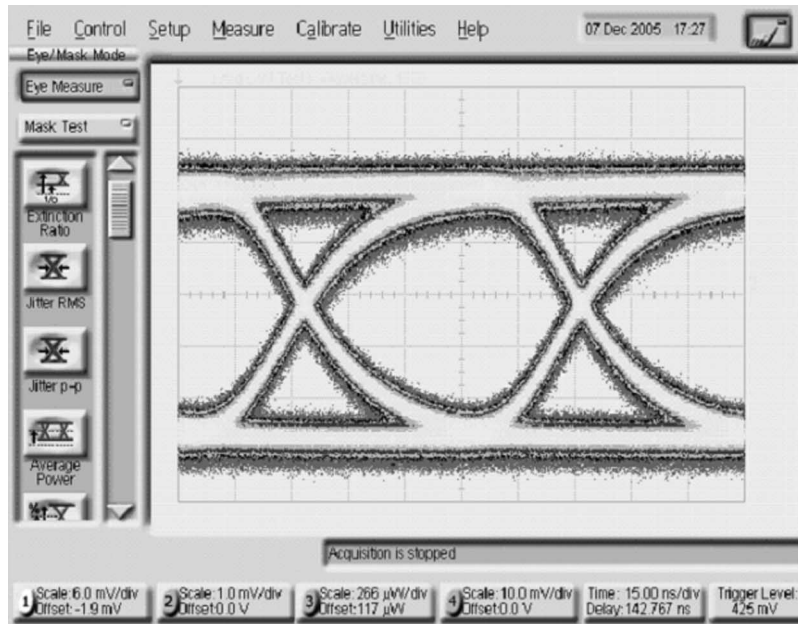

Fig. 3. BER before FEC versus received optical power for the back-to-back and after-300-m cases. The FEC failure level, which corresponds to pre-FEC BER  $\cong 10^{-3}$ , is also indicated.

coder, the chosen RS FEC code was an RS(1023 959), which directly handles 10-bit words. This code has the capability to correct up to 32 10-bit words in a 1023-word block; it gives a quasi-error-free operation (BER  $< 10^{-12}$ ) for an input BER  $< 10^{-3}$ ; to achieve this result, 64 redundant words are added to each 959 input data word, given an overhead of 6.67%. Since all data are arranged in bytes before the 8B/10B block and in 10-bit words after it, they are processed in a parallel way by the logical core. Data parallelization helps in achieving the required speed rate by using low-cost digital electronics. As shown in Fig. 2, the FEC block is directly followed by a serializer with interfaces directly with the POF physical interface, i.e., with the optoelectronics by a continuous NRZ binary stream. Taking into account the overhead introduced by 8B/10B, FEC, and ASM, the resulting line bit rate is 13.64 Mb/s. This rate is compatible with the 9-MHz available bandwidth for the target 400-m PMMA-SI-POF system without requiring special compensation techniques, such as adaptive equalization.

- 5) *Optoelectronic transceiver*: It is composed by a LED working in the green region of the visible spectrum, as mentioned at the beginning of Section II, and a photodiode with an integrated transimpedance amplifier at the receiver side. Serial data from the logical core are transferred to the LED by means of a commercial LED driver (Microlinear ML4632), while the received data are quantized by a digital comparator (Microlinear ML4622) before it is transmitted back to the logical core.
- 6) *Data recovery*: At the receiver side, before carrying out all the previously described processes in inverse order, a fully digital data recovery algorithm is implemented. We used a modified version of the data recovery oversampling technique described in [9] and long-term phase-locked-loop-like averaging in the clock recovery to minimize jitter in the sampling point in the middle of each received bit. Without going into its details, we only mention that the implemented data recovery algorithm allows to reach a sensitivity limit that is very close to the



(a)

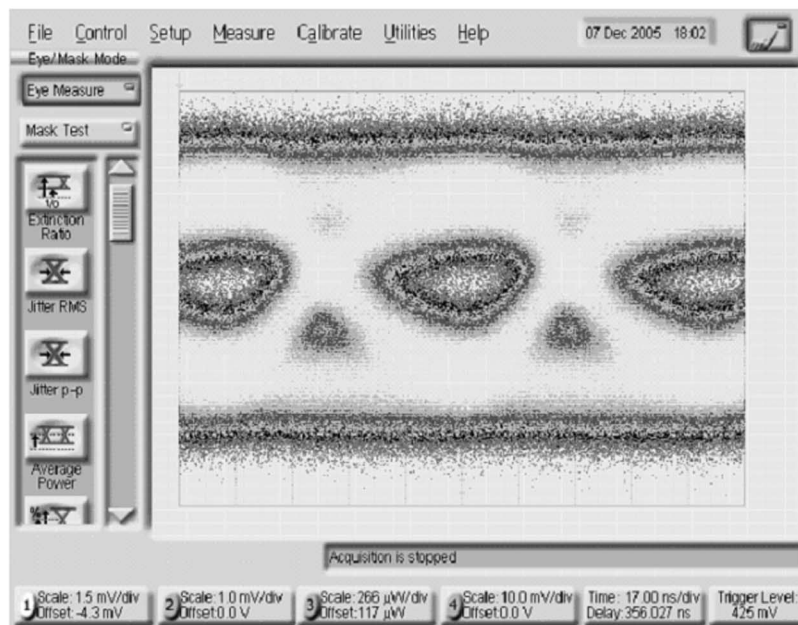

(b)

Fig. 4. Eye diagrams for (a) 300 m in a single span and (b) 400 m including one connector of PMMA-SI-POF.

theoretical value, which can be estimated by considering the transimpedance amplifier as the limiting noise source. The obtained high-performance levels, as will be explained in the next section, would be impossible without an optimized data recovery algorithm, which in turn requires a transmitter that forces continuous transmission (due to the rate-adaptation functionality) and high transition density (due to the 8B/10B standard).

After recovery, the data are deserialized in order to be fast processed in a parallel format by the FEC and the 8B/10B decoder. Moreover, the original Ethernet traffic, including the proper time gap between frames, is reassembled using the rate-adaptation unit, which removes idle words.

#### IV. SYSTEM PERFORMANCE

The described system implements a fully compliant 10-Mb/s Ethernet full-duplex link. In this section, we report its characterization in terms of BER performance. Fig. 3 shows pre-FEC BER versus received power plots for two different link configurations: 1) back-to-back and 2) after 300 m of PMMA-SI-POF. Considering that the used FEC starts to fail for a pre-FEC BER of about  $10^{-3}$ , the figure shows that the resulting global receiver sensitivity is about  $-37$  dBm of the incoming power at the receiver side. Given an average transmitted power of 1 dBm for the used green LED, the resulting power margin is 38 dB, which is a value that allows a 400-m link including one to two connectors and a 3-dB system margin, as explained in

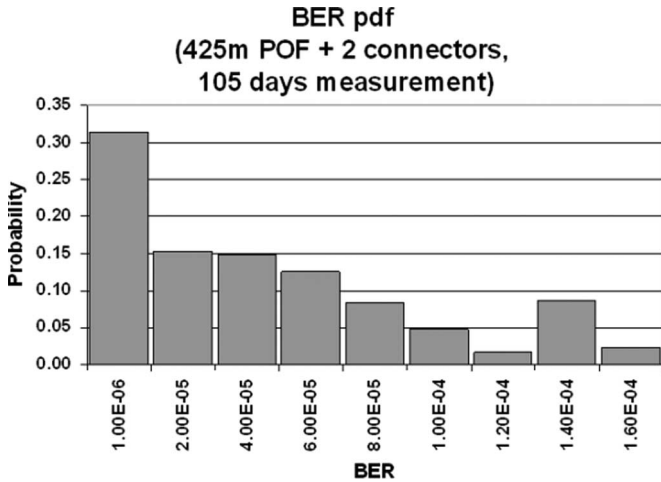

Fig. 5. BER probability density function obtained in a 105-day long-term measurement over a 425-m link.

Section II. The figure also shows that fiber-related impairments are small. In fact, for BER = 10<sup>-8</sup>, the figure evidences a 0.5-dB power penalty when 300 m of fiber is used (with respect to the back-to-back case). The power penalty gets even smaller for higher BER values, demonstrating that the intersymbol interference introduced by multimodal dispersion at the operating bit rate is very low.

Fig. 4 shows the eye diagram obtained after 300- and 400-m fiber spans. In both cases and in particular in the latter case, even though the eye is quite degraded, the receiver setup still gives an error-free condition, due to optimized clock and data recovery, and FEC coding.

Finally, several long-term measurements have been carried out over a record distance of 425 m, which turns out to be our system’s ultimate limit. Fig. 5 shows the result of this test by reporting, as a histogram, the probability density function of the obtained BER after a continuous 105-day measurement. Reminding that the selected RS-FEC fails when there are more than 32 erroneous words per 1023-word block, which is a situation that corresponds to a BER of approximately 10<sup>-3</sup>, the graph shows that this threshold value was never reached, demonstrating that no errors after FEC have been observed in 105 days over 425 m.

All the previously presented results have been obtained, feeding the system with either a continuous DVD quality video stream running between two PCs or real traffic coming from an FTTH connection from an Italian operator. The used fibers are part of a real POF LAN test bed, i.e., they are deployed in the same ducts used in our premises for the standard LAN cabling.

V. TEMPERATURE CHARACTERIZATION

One of the issues that often arise when using PMMA-SI-POF in the green window is the fiber thermal behavior [11]. Thus, we have tested our system characteristics under severe temperature variations. In particular, thermal stability measurements have been carried out by inserting the fiber spool in a climatic chamber. We focus on a thermal cycle that is repeated every 12 h. Each cycle starts with 3 h at a constant temperature of 80 °C, followed by a 3-h falling edge toward the next tem-

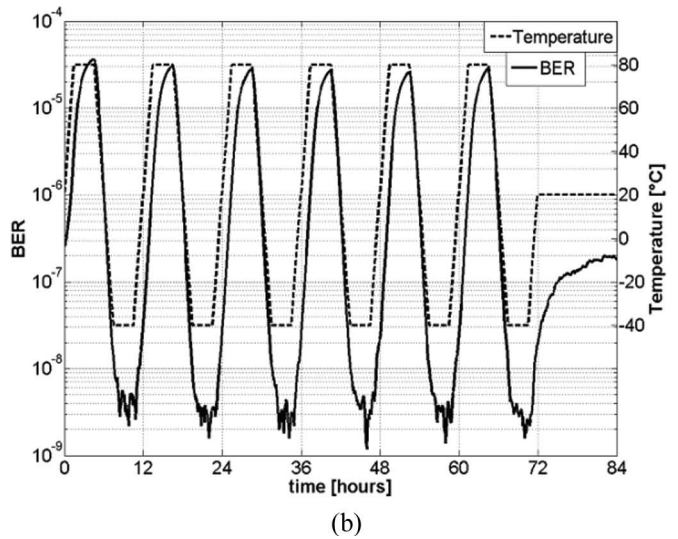
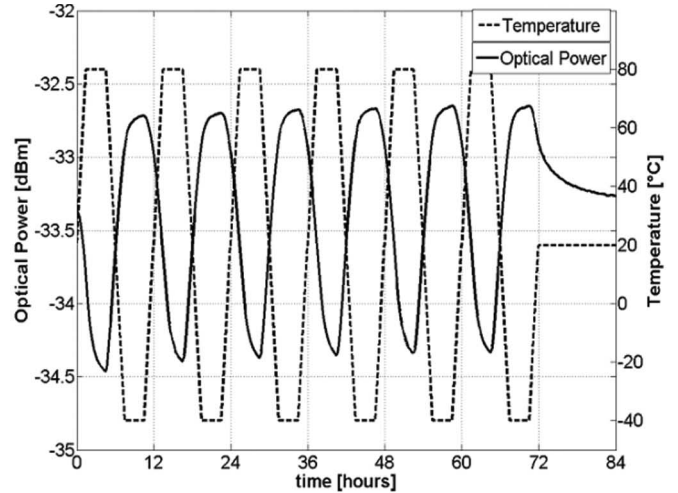

Fig. 6. Temperature stability measurement for a 300-m link. (a) Optical received power versus time. (b) BER versus time. Both graphs also show temperature-evolution plots.

perature stage at -40 °C, a second 3-h stop at -40 °C, and a final 3-h rising edge that leads again to 80 °C. The result of a 100-h measurement over 300-m PMMA-SI-POF is shown in Fig. 6 by reporting the resulting received power. The figure also shows the measured BER, which was forced to 10<sup>-7</sup> at room temperature in order to be measurable during the test by adding an attenuator at the output of the 300-m fiber. The resulting power variation during the test was smaller than 2 dB, and the resulting BER swing was from 8 · 10<sup>-4</sup> to 9 · 10<sup>-8</sup>. These results, although not exhaustive yet, show that the system may tolerate temperature variation that is much higher than that found in most environments, particularly in in-building installations.

VI. CONCLUSION

This paper constitutes a proof of concept of the usage of PMMA-SI-POF not only in short-reach applications below 100 m but also in extended-reach applications above 400 m by demonstrating a fully compliant 10-Mb/s Ethernet to a

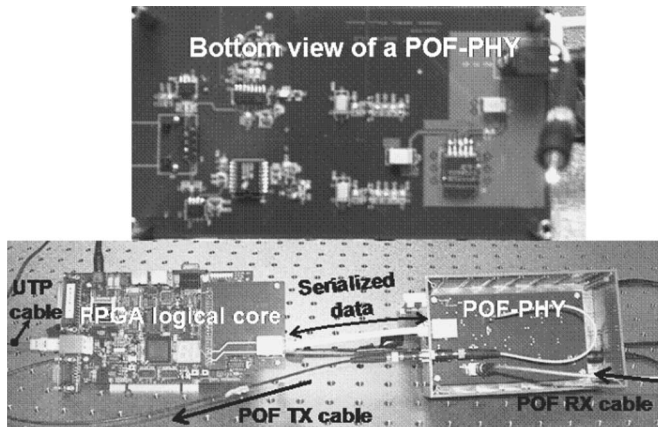

Fig. 7. Photograph of the full system and an enlarged image of the POF-PHY (bottom side).

PMMA-SI-POF media converter. The proprietary protocol has been implemented on a commercial FPGA, and the full system is shown in Fig. 7. Besides edge networks, our system may find application in other niche sectors, such as any industrial-like environment where the data rate to be transmitted is not very high but where harsh environmental conditions (dust, EMI interference, etc.) make the use of other transmission media difficult or even impossible.

A demonstration of the extended-reach use of large-core PMMA-SI-POF is the main goal of this paper. An upgrade of the system to higher bit rates, specifically to 100 Mb/s over 300 m, is one of the main targets of the new EU project POF-ALL (STREP in IST-FP6) and is currently under investigation [17].

## REFERENCES

- [1] W. Daum, J. Krauser, P. Zamzow, and O. Ziemann, *Polymer Optical Fibers for Data Communications*. New York: Springer-Verlag, 2002.
- [2] T. Schaal, T. Kibler, and E. Zeeb, "Optical communication systems for automobiles," presented at the Eur. Conf. Optical Commun. (ECOC), Stockholm, Sweden, Sep. 2004, TH3.1.3.
- [3] T. Freeman, "Plastic optical fibre tackles automotive requirements," *Fibre System Europe Magazine*, pp. 14–17, May 2004.
- [4] A. X. Widmer and P. A. Franaszek, "A DC-balanced, partitioned-block, 8B/10B transmission code," *IBM J. Res. Develop.*, vol. 27, no. 5, pp. 440–451, Sep. 1983.
- [5] T. Ishigure, K. Makino, S. Tanaka, and Y. Koike, "High-bandwidth graded-index polymer optical fiber enabling power penalty-free gigabit data transmission," *J. Lightw. Technol.*, vol. 21, no. 11, pp. 2923–2930, Nov. 2003.
- [6] T. Nyu, M. Momona, S. Yamazaki, A. K. Dutta, and A. Suzuki, "Fast Ethernet system with high-speed plastic optical fiber data links," in *Proc. OFC*, San Jose, CA, Feb. 1996, pp. 221–223.
- [7] O. Ziemann and J. Krauser, "The use of polymer optical fiber for in-house networks, advantages of 520 nm LED transmission systems," in *Proc. ECOC*, Madrid, Spain, Sep. 20–24, 1998, pp. 379–380.
- [8] S. Benedetto and E. Biglieri, *Principles of Digital Transmission With Wireless Applications*. New York: Kluwer, 1999, ch. 11.
- [9] N. Sawyer, *Data Recovery*, 2005. Xilinx Application Note 224.
- [10] J. Mateo, M. A. Losada, I. Garcés, J. Arrue, J. Zubia, and D. Kalymnios, "High NA POF dependence of bandwidth on fibre length," in *Proc. POF Conf.*, Seattle, WA, Sep. 2003, pp. 123–126.
- [11] K. Irie, T. Yoshimura, K. Nakamura, and Y. Kawaharada, "Analysis on long-term reliability of polymer optical fiber," in *Proc. POF Conf.*, Nürnberg, Germany, Sep. 2004, pp. 611–617.
- [12] A. Nespola, D. Cárdenas, P. Spalla, and R. Gaudino, "A media converter and a system for mutually converting a packet-based data stream into a serial data stream," EU Patent 05020517.8, Sep. 20, 2005. (temporary number).
- [13] T. Muoi, "Receiver design for digital fiber optic transmission systems using Manchester (biphase) coding," *IEEE Trans. Commun.*, vol. COM-31, no. 5, pp. 608–619, May 1983.
- [14] J. Everitt, J. F. Parker, P. Hurst, D. Nack, and K. R. Konda, "A CMOS transceiver for 10-Mb/s and 100-Mb/s Ethernet," *IEEE J. Solid-State Circuits*, vol. 33, no. 12, pp. 2169–2177, Dec. 1998.
- [15] D. Cárdenas, A. Nespola, R. Gaudino, S. Abrate, and C. Lezzi, "FFTH in Italy: The fastweb access infrastructure and its possible evolution with new PMMA-SI-POF media converters," in *Proc. IEE Conf. Access Technol. (ICAT)*, Cambridge, U.K., Jun. 21–22, 2006, pp. 1–4.
- [16] HOME PLANET (IST-2000-28234), EU research project, see *Approach* in official web site. [Online]. Available: <http://www.tyndall.ie/projects/homeplanet/>
- [17] POF-ALL (IST-2006-027549), EU research project, see *Workpackages* in official web site. [Online]. Available: <http://www.ist-pof-all.org/>



**Daniel Cárdenas** received the M.Sc. degree in telecommunications engineering from Escuela Politécnica Nacional, Quito, Ecuador, in 2003, and the postgraduate certificate in optical communications and photonic technologies from Politecnico di Torino, Torino, Italy, in 2004. He is currently working toward the Ph.D. degree at Politecnico di Torino as a member of the Optical Communications Group.

From 2001 to 2003, he was with the Department of Electronics, Geophysics Institute, Quito, Ecuador, where he was involved in analog and/or digital data acquisition systems design. He is a coauthor of a patent in the field of telecommunications over plastic optical fibers. His current research activities include polymer-optical-fiber-based access systems, which he carries out at the Photon Laboratory, Istituto Superiore Mario Boella, in collaboration with Politecnico di Torino.



**Antonino Nespola** received the M.S. and Ph.D. degrees in electrical engineering from Politecnico di Torino, Torino, Italy, in 1995 and 2000, respectively.

From 1997 to 1998, he was a Visiting Researcher at the Photonics Laboratory, University of California, Los Angeles. From 1999 to 2003, he was member of Technical Staff and the R&D Lab Director in Corning, Milan, where he conducted research in high-speed optoelectronics. In 2003, he joined Pirelli Labs, Milan, Italy, as a Senior Researcher in a project that deals with the design of high-frequency silicon photonic circuits based on CMOS technology. He is currently with Istituto Superiore Mario Boella, Torino, Italy, where he is a Project Manager on fiber-optic and plastic fiber-optic system communication and related optoelectronics transceiver designs. He has published more than 20 journal and conference papers. He is the holder of three U.S./European patents.



**Pietro Spalla** received the M.Sc. degree in electronic engineering and the postgraduate certificate in optical telecommunications and photonic technologies from Politecnico di Torino, Torino, Italy.

He is currently the Manager of Intellectual Assets with Torino Wireless, Torino. His professional activity started at the Istituto Superiore Mario Boella, a private–public research institute, as a Research Assistant working on "short-reach" optical links using plastic optical fibers. Since October 2005, he has been with the Intellectual Asset Management Department, Torino Wireless, where he takes care of the patenting and the management of technology transfer issues. He is a coinventor of a patent in the field of telecommunications over plastic optical fibers.

Mr. Spalla is a member of the Licensing Executive Society-Italy, which is the international forum that gathers Intellectual Property Rights (IPR) professionals.



**Silvio Abrate** (M'04) received the M.Sc. degree in telecommunications engineering from Politecnico di Torino, Torino, Italy, in 1999. His thesis was about the distribution of satellite television over an in-building fiber infrastructure.

Since 2001, he was with the Optical Networks Division, Alcatel S.p.A., Vimercate (MI), Italy, working on synchronous-digital-hierarchy and wavelength-division-multiplexing networks especially for Telecom Italia and South America's providers. Since February 2003, he has been a Senior

Researcher with Istituto Superiore Mario Boella, Torino, and the Coordinator of the PHOtonic Technologies and Optical Networks Laboratory (PhotonLab), which is held by the institute in cooperation with Politecnico di Torino.



**Roberto Gaudino** (M'98) received the M.Sc. and Ph.D. degrees in electrical engineering from Politecnico di Torino, Torino, Italy, in 1993 and 1998, respectively.

He is currently an Associate Professor with the Dipartimento di Elettronica, Politecnico di Torino. Previously, his research was on fiber modeling and new optical modulation formats such as duobinary, polarization, or phase modulation, and coherent optical detection. Currently, he is investigating packet-switched optical networks and short-reach optical links using plastic optical fibers. In 1997, he spent one year at the Georgia Institute of Technology, Atlanta, as a Visiting Researcher, where he worked in the realization of the MOSAIC optical network test bed. He also cooperates with several Italian universities and research centers on joint research programs. Since 1998, he has been with the team that coordinates the development of the commercial optical system simulation software OptSim (Artis Software Corporation, which has now been acquired by RSoft Design). He has consulted for several companies and is the author and coauthor of more than 80 papers in the field of optical fiber transmission and optical networks. He is currently the Coordinator of the EU FP6-IST STREP project "POF-ALL" and is also coordinating one of the work packages of the EU FP6-IST NoE e-Photon/ONe. His research interests include long-haul dense-wavelength-division-multiplexing systems, fiber nonlinearity, modeling of optical communication systems, and experimental implementation of optical networks.