

Economical Benefits of Dispersed Trigeneration

*Original*

Economical Benefits of Dispersed Trigeneration / Cavallero, CLAUDIO DOMENICO; Canova, Aldo; Freschi, Fabio; Giaccone, Luca; Tartaglia, Michele; Repetto, Maurizio. - STAMPA. - (2007), pp. 193-200. (Intervento presentato al convegno SB 2007 tenutosi a TORINO, ITALY nel JUN 7-8 2007).

*Availability:*

This version is available at: 11583/1639744 since:

*Publisher:*

*Published*

DOI:

*Terms of use:*

This article is made available under terms and conditions as specified in the corresponding bibliographic description in the repository

*Publisher copyright*

(Article begins on next page)

# ECONOMICAL BENEFITS OF DISPERSED TRIGENERATION

## Primary Author

Corso Duca degli Abruzzi,24  
Torino, Italy

**Claudio CAVALLERO Dr. Eng.<sup>1</sup>**

<sup>1</sup> Politecnico di Torino, Torino, Italy, claudio.cavallero@polito.it

## Co-Author(s)

Corso Duca degli Abruzzi,24  
Torino, Italy

**Aldo CANOVA Prof.<sup>2</sup>, Fabio FRESCHI Ph.D<sup>2</sup>, Luca GIACCONE Dr. Eng.<sup>2</sup>, Michele TARTAGLIA Prof.<sup>2</sup>,  
Maurizio REPETTO Prof.<sup>2</sup>**

<sup>2</sup> Politecnico di Torino, Torino, Italy

**Keywords:** cogeneration, trigeneration, optimization, economical investments.

## Summary

In last years the study of new power systems which are more efficient than traditional ones became more and more important. This is necessary due to the increase of both fuels cost and power request. Examples of these systems are co-generative and trigenerative plants, in which are installed respectively Combined heat and power (CHP) and Combined heating, cooling and power (CHCP). Although the investments for the installation of these plants are very high, they can be economically convenient if well designed and managed.

In this paper it is shown an optimization model for trigenerative plants based on Mixed Integer Linear Programming. This model is applied to a test case regarding the Italian site of POLYCITY project. Power plant installed in this district is made by one 1 MW CHP, three boilers, one absorption and one electrical chiller. There are 40 apartment buildings and an office building. Our attention is focused on showing how it is possible to increase the profit by managing the plant in the optimal way instead of using a fixed scheme. Besides there is a comparison among the profits that would be obtained using different CHPs, each of them managed with the optimal profile.

## 1. Introduction

A Combined Heat and Power (CHP) node is a generating power unit where electrical and thermal power are generated together. These units are installed close to the user, therefore the thermal energy related to the electricity production, that usually is wasted, can be used to cover the user thermal demand. In this way the combined power source has an energy efficiency higher than using two separated units: one for electric and one for thermal power generator.

The operational planning of the integrated unit must supply in time both electric and thermal requirements of the loads which often have different scheduling and, when it is economically convenient, it can buy or sell electrical power to the electrical local utility. Examples of this application can be found in district heating and in industrial processes. The management of this energy production unit is not an easy task when energy prices are time varying on a daily or weekly basis, thus requiring an optimal management of production scheduling. All these reasonings about the management of the system have the purpose to understand when it is economically convenient to install a CHP and what size best fits the user energy demand.

With the addition of one or more absorption chillers it is possible to get a trigenerative system. This kind of system is called Combined Heat Cooling and Power in [1]. It works supplying cooling power obtaining it from recovered heat from steams or hot water of CHP. Besides compressor chillers can be used as auxiliary systems to supply cooling power. These components allow to install a trigenerative plant.

## 2. Model Description

In this paragraph a modelization devoted to the optimal management of a energy system is presented. The system is composed by a CHP, which satisfies both electrical and thermal loads. Exceeding electrical power can be sold to external network, or can be use to make an electrical chiller to work if cooling power is requested. Exceeding thermal power can be stored in a thermal storage, can be used to feed an absorber chiller or can be wasted into the environment. At last there is a boiler which can give thermal power to the

thermal load, to the absorption chiller or to the thermal storage. It may happen that one or more of these components is omitted (e.g: there is no chiller). The site is shown in Fig. 1

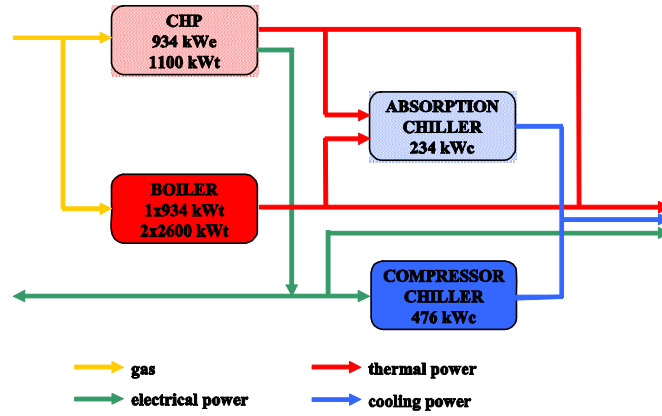

Figure 1 Scheme of power system

The proposed optimization procedure is based on the Mixed Integer Linear Programming (MILP) formulation, as proposed in [2]. This is due to the fact that the problem is still linear, but it has both continuous and integer variables. This class of problems can be solved by exact methods like Branch and Bound technique [3].

The proposed procedure is time dependent and the optimization is run for a certain number ( $N_\tau$ ) of time intervals, with length  $\Delta t$ . Model has variables, constrains and constant data are reported and described in Table 1, Table 2 and Table 3

Table 1 Model Variables

$(i)$	time interval
$P_e^j$	electrical power produced by the $j$ -th CHP
$P_p$	electrical power purchased from the external network
$P_s$	electrical power sold to the external network
$P_{cc}^j$	electrical power required by the $j$ -th compressor chiller
$U_e$	electrical load
$P_t^j$	thermal power produced by the $j$ -th CHP
$B_t^j$	thermal power produced by the $j$ -th boiler
$D_t^j$	thermal power produced by the $j$ -th CHP and wasted into the atmosphere
$B_{ac}^j$	thermal power required by the $j$ -th absorption chiller
$U_t$	thermal load
$U_c$	cooling load
$\delta_e^j, y_e^j, z_e^j$	logical variables defining the on/off status of the $j$ -th CHP
$\delta_t^j, y_t^j, z_t^j$	logical variables defining the on/off status of the $j$ -th boiler
$\delta_p, \delta_s$	logical variables defining the purchasing/selling relation wrt the external network

Table 2 Constant data

$N_{CHP}$	number of CHPs
$N_{CC}$	number of compressor chillers
$N_{BOIL}$	number of boilers
$N_{AC}$	number of absorption chillers
$\eta_{cc}^j$	efficiency of the $j$ -th compressor chiller
$\eta_{ac}^j$	efficiency of the $j$ -th absorption chiller
$k_0, k_1$	interpolation coefficients defining the $P_t = f(P_e)$ relation
$p_e^{j,min}$	lower bound of electrical power produced by the $j$ -th CHP
$p_e^{j,max}$	upper bound of electrical power produced by the $j$ -th CHP
$\theta_e^{j,on}$	minimum on time of the $j$ -th CHP
$\theta_e^{j,off}$	minimum shutdown time of the $j$ -th CHP
$B_t^{j,min}$	lower bound of thermal power produced by the $j$ -th boiler
$B_t^{j,max}$	upper bound of thermal power produced by the $j$ -th boiler
$\theta_t^{j,on}$	minimum on time of the $j$ -th boiler
$\theta_t^{j,off}$	minimum shutdown time of the $j$ -th boiler
$N_{sw,e}^{j,max}$	maximum number of switching operations allowed for the $j$ -th CHP
$N_{sw,t}^{j,max}$	maximum number of switching operations allowed for the $j$ -th boiler
$N_\tau$	number of time intervals
$p_p^{max}$	upper bound of electrical power purchased from the electrical network
$p_s^{max}$	upper bound of electrical power sold to the electrical network

Table 3 Constrains of model

N.	Constrain			
1	$\sum_{j=1}^{N_{CHP}} P_e^j(i) + P_p(i) - P_s(i) - \sum_{j=1}^{N_{CC}} P_{cc}^j(i) = U_e(i)$			
2	$\sum_{j=1}^{N_{CHP}} P_t^j(i) + \sum_{j=1}^{N_{BOIL}} B_t^j(i) - \sum_{j=1}^{N_{CHP}} D_t^j(i) - \sum_{j=1}^{N_{AC}} B_{ac}(i) = U_t(i)$			
3	$\sum_{j=1}^{N_{CC}} \eta_{cc}^j P_{cc}^j(i) + \sum_{j=1}^{N_{AC}} \eta_{ac}^j B_{ac}^j(i) = U_c(i)$			
4	$P_t^j(i) = f(P_e^j(i)) = \frac{\eta_t(P_e^j(i))}{\eta_e(P_e^j(i))} P_e^j(i) \cong k_0 + k_1 P_e^j(i)$			
5	$D_t^j(i) \leq P_t^j(i)$			
6	for each $j$ -th CHP (and for each $j$ -th boiler)			
	A1	$\delta_e^j(i) P_e^{j,\min} \leq P_e^j(i) \leq \delta_e^j(i) P_e^{j,\max}$	A2	$\delta_t^j(i) P_t^{j,\min} \leq B_t(i) \leq \delta_t^j(i) B_t^{j,\max}$
	B1	$y_e^j(i) - z_e^j(i) - \delta_e^j(i) + \delta_e^j(i-1) = 0$	B2	$y_t^j(i) - z_t^j(i) - \delta_t^j(i) + \delta_t^j(i-1) = 0$
	C1	$y_e^j(i) + z_e^j(i) \leq 1$	C2	$y_t^j(i) + z_t^j(i) \leq 1$
	D1	$\sum_{k=i}^{i+\theta_e^{j,on}-1} \delta_e^j(k) \leq \theta_e^{j,on} y_e^j(i)$	D2	$\sum_{k=i}^{i+\theta_t^{j,on}-1} \delta_t^j(k) \leq \theta_t^{j,on} y_t^j(i)$
	E1	$\sum_{k=i-\theta_e^{j,off}+1}^i [1 - \delta_e^j(k)] \leq \theta_e^{j,off} z_e^j(i)$	E2	$\sum_{k=i-\theta_t^{j,off}+1}^i [1 - \delta_t^j(k)] \leq \theta_t^{j,off} z_t^j(i)$
	F1	$\sum_{i=1}^{N\tau} y_e^j(i) \leq N_{sw,e}^{j,\max}$	F2	$\sum_{i=1}^{N\tau} y_t^j(i) \leq N_{sw,t}^{j,\max}$
	7	$P_p(i) \leq \delta_p(i) P_p^{\max}$		
8	$P_s(i) \leq \delta_s(i) P_s^{\max}$			
9	$\delta_p(i) + \delta_s(i) \leq 1$			

Description of constraints

- 1)-2)-3) Satisfaction of electrical, thermal and cooling loads respectively
- 4) Relationship between electrical and thermal power produced by CHP
- 5) Just thermal power produced by CHP can be wasted into the environment
- 6A1) CHP must satisfy its technical limits
- 6B1) First relationship among integer variables of CHP
- 6C1) Second relationship among integer variables of CHP
- 6D1) CHP must satisfy its MOT limit
- 6E1) CHP must satisfy its MST limit
- 6F1) CHP can turn on at more  $N_{sw,e}^{j,\max}$  times
- 6A2) Boiler must satisfy its technical limits
- 6B2) First relationship among integer variables of Boiler
- 6C2) Second relationship among integer variables of Boiler
- 6D2) Boiler must satisfy its MOT limit
- 6E2) Boiler must satisfy its MST limit

6F2) Boiler can turn on at more  $N_{sw,t}^{j,max}$  times

7) Electrical power can be purchased at  $i$ -th time interval only if integer variable  $\delta p$  has value one

8) Electrical power can be sold at  $i$ -th time interval only if integer variable  $\delta s$  has value one

9) At  $i$ -th instant time it is possible just to sell or purchase electrical power

As can be seen from the table Table 1 both continuous variables, as the power levels (S or P), and integer variables, as the on/off device behaviour conditions, are present in the model.

### 3. Simulation

A realistic case regarding the electrical and thermal plant of a district of Turin has been analyzed. The study is developed in the ambit of an European Project called POLYCITY [4]

It was supposed to supply energy requirement with a CHP and three boilers. Several Caterpillar engines were simulated. The graph reported show the thermal and electrical daily energy behaviour in of the sources and loads considering a CHP with rated electrical power of 985 kWe. Four typical days are analysed: spring, summer, autumn and winter day. Seasons have following returns:

- 1) spring: 92 days
- 2) summer: 94 days
- 3) autumn: 89 days
- 4) winter: 90 days

For each typical day the energy requirement of the loads are known. Observing the electrical curves (Fig. 2) it is interesting to observe that the optimised cogenerator behaviour requires a full power production for about 14 hours (between 7 am and 9 pm) in spring and in summer and for about 20 hours (between 4 am and 12 pm) in autumn and in winter. This working behaviour difference is due to the greater thermal absorption in the cold seasons. In is important to point out that the cogenerator electrical power is much greater than the electrical load and so a considerable amount of electric energy is sold in all the typical days when the cogenerator is switch on. The only electrical energy required form the network is due to the electrical load during the night.

The thermal characteristics (Fig. 3) show that during spring and summer the cogenerator is sufficient to provide all the thermal energy required from the loads. In this seasons only one boiler, the smallest one, works for few hours during the night, when the cogenerator is switch off, while the other boilers do not work. The thermal energy produced by the cogenerator, especially during spring season, is in excess and a thermal dissipation occurs. This results is justified from the fact that the optimisation find the minimum of the cost function and during the day is it convenient to produce and sell electric energy even if the thermal one is lost. It is worth to underline that this results take into account also the "thermal limits" constraints that imposes a lower limit for the real utilization on the heat generated. The thermal limit expression is shown below:

$$TL = \frac{E_T}{E_T + E_E} \quad (1)$$

The Italian law impose different limit on the TL depending on the size of the plant. In our cases for all the engines analyzed the TL must be higher than 33% [5].

In the autumn and winter seasons all the cogenerator thermal energy is absorbed from the load which requires also the contribution of the boilers and the thermal dissipation of the cogenerator is negligible. Moreover, the working cycle behavior of the three boilers is optimized in order to satisfy for each boiler, the constraint of a minimum power generation and to minimize their number of switch off and on: important aspects for the efficiency, maintenance and pollutants emissions.

Finally in Fig. 4 are reported the daily behavior of the storage thermal energy due to water contained inside the district heating network pipes.

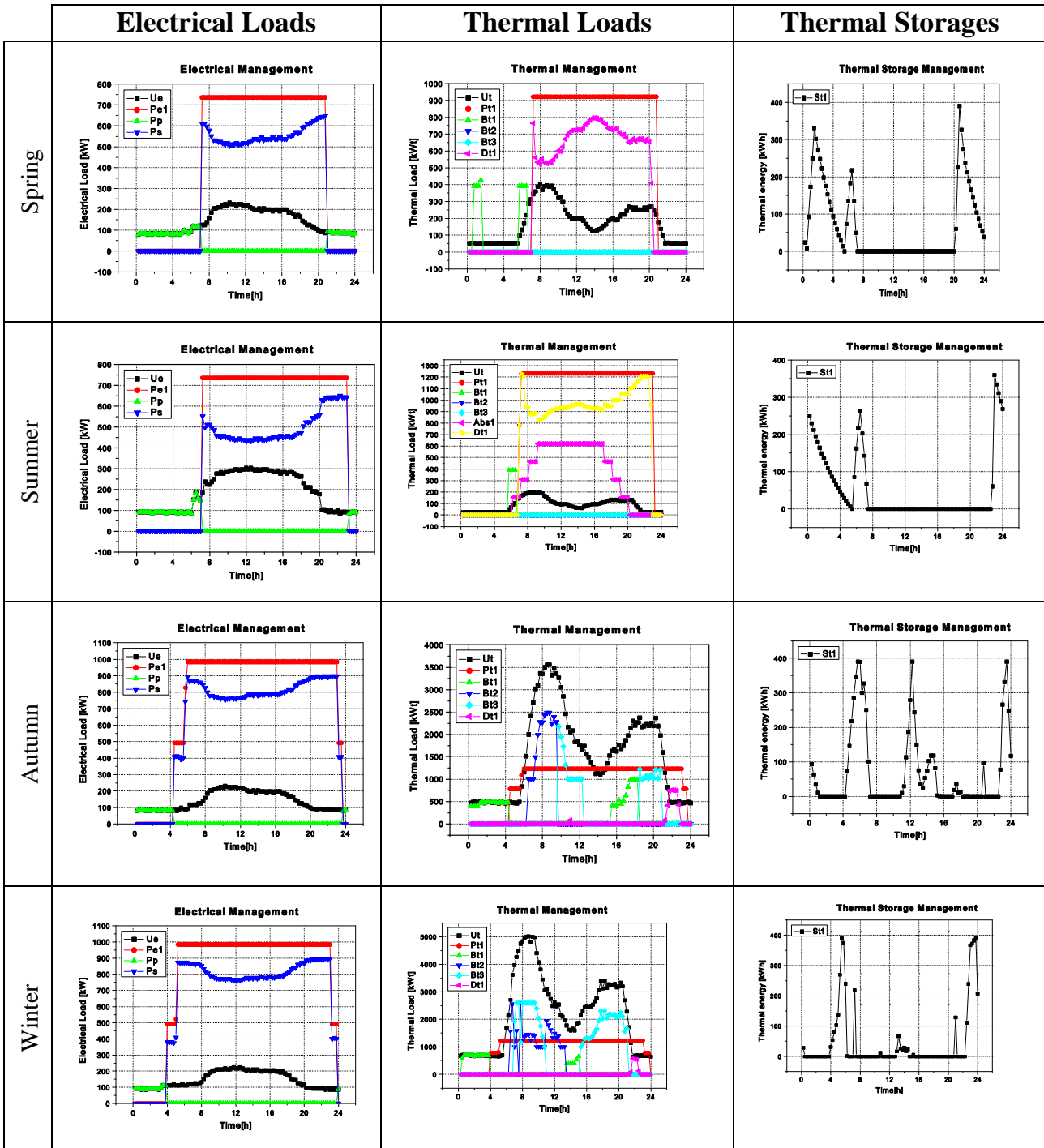

Figure 2 Electrical managements

Figure 3 Thermal managements

Figure 4 Thermal storages

The previous analysis has been carried out for different CHP sizes. A similar study was made by [6], but without an optimal management of the system and without comparing several CHP among them. For each CHP has been conducted a cash flow analysis which provide the pay back time (PBT) of the investment. In Fig. 5 the curves of the Net Present Value (NPV) are reported considering a period of 20 years. The results show that all the CHP size has practically the PBT of about 4 years, but increasing the CHP power the final NPV significantly increase; on the other hand the initial investment is higher and the choice of a CHP of about 1 MW is related also to the risk that the investor is available to make. It was supposed that CHP had been paid 1000 € per kWe.

In this work it is not considered a constrain regarding thermal limit (TL). This limit would force wasted thermal power not to exceed 66% of thermal power produced by CHP. This constrain is required to consider this kind of generation of power as cogeneration. Even if this constrain is not taken into account is satisfied. With power production shown in Fig. 2 TL of 985 kWe is 36%

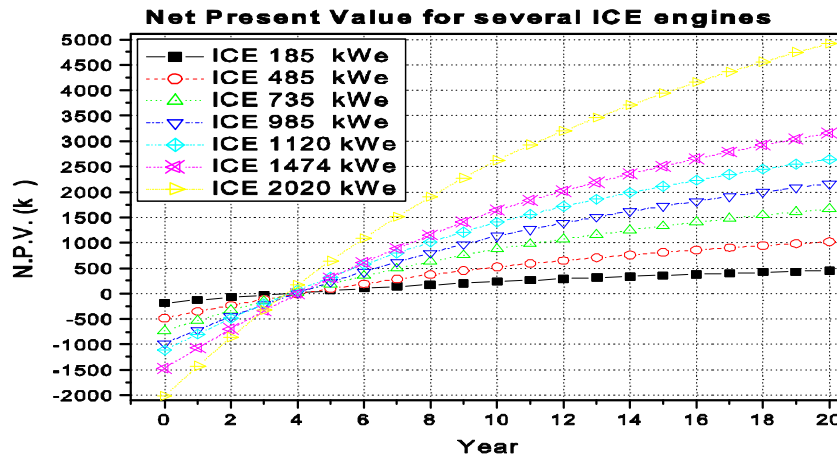

Figure 5 NPV for 20 years

Also economical analysis was studied. Efficiency of CHP with rate power 985 kWe is simulated with three different kind of managements:

- 1) CHP kept on from 7 a.m. to 8 p.m. producing rate power;
- 2) optimization decides when turn CHP on and off producing always rate power;
- 3) optimization decides both when to turn CHP on and off and electrical power rate production.

In Fig. 6 it is possible to see the Net Payback Value versus years for the engine ICE 985 kWe when it is managed with several criteria:

- Not optimised management: CHP is kept on from 7 a.m to 8 p.m. producing rated electrical power
- Fixed power management: CHP is free to choice the optimal on/off state (turning on just once a day) producing rated electrical power
- Optimised management: CHP is free to choice the optimal on/off state (turning on just once a day) and production level.

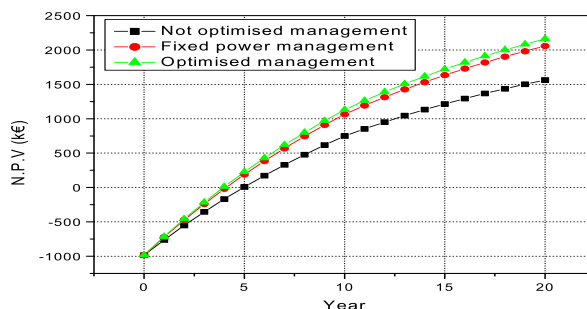

Figure 6 NPV variations related to the different optimization strategies

Table 4- Internal return rate and Pay Back Period for CHP of size 985 kWe with several kind of optimisations

	IRR [%]	PBP [Years]
<b>No Optimization</b>	23.1	5.0
<b>Fixed power</b>	27.8	4.1
<b>Optimized Management</b>	28.7	4.0

It is possible to observe that the optimized strategy allows reduction of 1 year in the PBP and an increment of about 4.5% in the IRR, see Table 4. Comparing the two optimization strategies, it is worth noting that the on/off states variable play the most important role while the regulation of the generation level does not improve significantly the optimal management.

#### 4. Conclusion

The installation of a CHCP plant requires a deep study about economical investments. This work shows an optimization procedure to foreseen a management of the system aimed to increase yield of investment. Future works could study a model taking into account evolution of thermodynamic phenomena which get in relationship several interval time among them.

Optimization procedure seems to work well as foreseen PBP is short if compared with other similar installed plants. Nothing can be said about IRR, whose quality depend on the kind of investment wished by the manager.

#### 5. Acknowledgments

This paper presents some results concerning the European Project POLYCITY (Sixth Framework Programme – Priority 6.1 - Sustainable Energy Systems). Therefore the authors would like to acknowledge the partner of the project who cooperated to this work.

#### References

- [1] G. Chicco and P. Mancarella, "From Cogeneration to Trigeneration: Profitable Alternatives in a Competitive Market", IEEE Transaction on Energy, 21(1) pp.265-272, March 2006
- [2] J. M. Arroyo and A. J. Conejo, "Optimal response of a thermal unit to an electricity spot market". IEEE Transactions on Power Systems, 15(3) pp.1098– 1104, Aug. 2000.
- [3] L. A. Wolsey and G. L. Nemhauser, "Integer and Combinatorial Optimization", Wiley-Interscience, 1st edition, 1999.
- [4] POLYCITY project. Available:<http://www.polycity.net>
- [5] E. Cardona, A. Piacentino, "Cogeneration: a regulatory framework toward growth", Energy Policy 33, pp.2100-2111, Nov. 2005
- [6] Fotios E. Karagiannis, "Central Cogeneration units in Athens – an economical approach", 10th Mediterranean Electrotechnical Conference, MEleCon 2000, pp.1032 - 1035 Vol. 111