

Multiport network analyzer self-calibration: a new approach and some interesting results

Original

Multiport network analyzer self-calibration: a new approach and some interesting results / Madonna, Gian Luigi; Ferrero, ANDREA PIERENRICO; Pisani, Umberto. - STAMPA. - 31:(1997), pp. 142-145. (Intervento presentato al convegno ARFTG Conference tenutosi a Denver, CO (USA) nel June 1997) [10.1109/ARFTG.1997.327222].

Availability:

This version is available at: 11583/1416371 since:

Publisher:

Published

DOI:10.1109/ARFTG.1997.327222

Terms of use:

This article is made available under terms and conditions as specified in the corresponding bibliographic description in the repository

Publisher copyright

(Article begins on next page)

Multiport Network Analyzer Self-Calibration: a New Approach and Some Interesting Results

GianLuigi Madonna, Andrea Ferrero and Umberto Pisani

Dipartimento di Elettronica
Politecnico di Torino
Corso Duca degli Abruzzi 24
10129 Torino, Italy

Phone: (xx3911) 5644082 Fax: (xx3911) 5644099 E-Mail: ferrero@polito.it

Abstract - A new approach to multiport network analyzer calibration is here presented. This solution exploits the redundancy of multiple standards connections in order to perform a multiport self-calibration. The method allows to use also partially or even fully unknown devices as standards. The algorithm is independent from a particular standard sequence. By this new approach, the user can tailor the known or unknown standard sequence to best fit the measurement needs and test set constrains. As an example we proved that the calibration of a three-port NWA can be carried out by the insertion of three known reflections at one port of the test-set, plus three connections of the same fully unknown two-port device.

I. INTRODUCTION

The need for comprehensive characterisation of complex devices and subsystems used in telecommunications is bringing new interest in multiport (i.e. more than two port) network analysis and measurement techniques. In the past, Speciale et alii [1] originally proposed to extend the two-ports TSD (Thru-Short-Delay) method as a solution for the calibration of an n -ports S-parameters test-set. Another technique was presented in [2], based on several partial two-ports measurements properly combined to account for the mismatch errors of the other $n-2$ ports. More recently, the authors and others introduced a general solution of the multiport calibration problem for a non-leaky [3,4] and a leaky test-set [5]. This solution is based on the insertion of a certain number of perfectly known standards, which the user can properly choose to

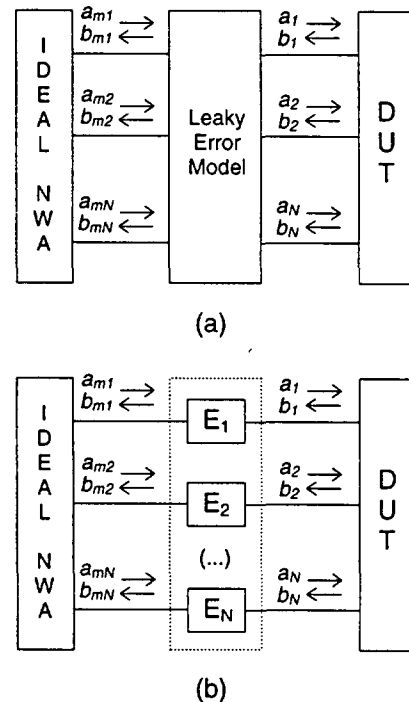

Fig.1. NWA error model. (a) Leaky test-set.
(b) Non-leaky test-set.

satisfy a given set of criteria. The opportunity of using partially unknown standards have already been investigated, but, to the authors' knowledge, a general formulation for the multiport case has not been published yet.

This paper presents a new approach which allows to perform a general multiport self-calibration. The method can be applied using error models with or without leakage between the measurement ports (figure 1) and it allows to use generic p -ports networks (where p can be equal to 1,2,... n) as standard devices. These networks can be partially or even fully unknown. The theory is based on the

iterative solution of two coupled linear systems derived from the classical multiport deembedding equation introduced in [5] and it is independent from the sequence and the type of the standards used.

With this approach, the user is able to tailor the calibration algorithm to fit the measurement needs. Traditional algorithms fix the type of standards to be used, thus they introduce constraints on the test-set and on the environment in which the measurement can be performed. For instance, a technique which uses a *thru* connection between two coaxial ports imposes a gender problem that may require an adapter removal procedure to be solved. Similarly, an algorithm that involves a *line* standard introduces severe geometrical limitations and it cannot be applied when the measurement ports are not faced (a common problem in on-wafer production testing with fixed probecards). The approach here presented allows to overturn the point of view: the constraints of the problem are no longer set by the calibration algorithm, but by the measurement environment and, in general, by the user needs.

II. THEORY FORMULATION

According to the linear error model shown in figure 1, an actual multiport network analyzer (NWA) can be seen as an error-free NWA, which acquires the raw waves a_{mi}, b_{mi} , and a $2n$ -port fictitious network which ties the ideal NWA to the n -port DUT. The deembedding equation is [5]:

$$\mathbf{S} = (\mathbf{M} - \mathbf{K}\mathbf{S}_m)(\mathbf{H} - \mathbf{L}\mathbf{S}_m)^{-1} \quad (1)$$

Matrices \mathbf{S} and \mathbf{S}_m are, respectively, the actual and the measured scattering matrix of the DUT, while \mathbf{M} , \mathbf{L} , \mathbf{H} and \mathbf{K} contain the error coefficients and become diagonal if a non leakage model is considered.

The aim of every calibration technique is to compute \mathbf{M} , \mathbf{L} , \mathbf{H} and \mathbf{K} from a proper set of standard measurements. As proved in [5], the calibration problem is reduced to the solution of a system of the form

$$\mathbf{N}\mathbf{u} = \mathbf{g} \quad (3)$$

Vector \mathbf{u} contains the v error coefficients, where $v=4n-1$ under the no-leakage assumption or $v=4n^2-1$ otherwise. Vector \mathbf{g} contains only elements of

the type S_{mij} or zeros, while matrix \mathbf{N} contains also the standard parameters S_{ij} .

In a multiport self-calibration, some of the standard parameters may be unknown and they have to be computed during the calibration process itself. We will now derive a new form of (6) able to obtain the unknown parameters of the standards as a by product of the calibration process.

Let \mathbf{s}^u a vector that contains the m unknown scattering parameters of the standards. It is easy to note that \mathbf{N} can be written as linear combination of matrices:

$$\mathbf{N} = \sum_{i=1}^m s_i^u \mathbf{N}_i + \mathbf{N}_0 \quad (4)$$

where $\mathbf{N}_0, \mathbf{N}_1, \dots, \mathbf{N}_m$ are sparse matrices and s_i^u are the m elements of \mathbf{s}^u . Thus equation (6) is rewritten as

$$\sum_{i=1}^m s_i^u \mathbf{N}_i \mathbf{u} + \mathbf{N}_0 \mathbf{u} = \mathbf{g} \quad (5)$$

The latter equation is a non-linear system in \mathbf{s}^u and \mathbf{u} which we solve numerically using an iterative technique based on the following considerations. If \mathbf{s}^u were known, (5) would be a linear system in the unknowns \mathbf{u} . The form of such system would be exactly (3), with matrix \mathbf{N} fully known. On the other side, assuming \mathbf{u} known, equation (5) can be rewritten as a linear system in the unknowns \mathbf{s}^u :

$$\mathbf{Y}\mathbf{s}^u = \mathbf{z} \quad (6)$$

where

$$\mathbf{Y} = [\mathbf{y}_1 \quad \mathbf{y}_2 \quad \dots \quad \mathbf{y}_m] \quad \text{and} \quad \mathbf{z} = \mathbf{g} - \mathbf{N}_0 \mathbf{u} \quad (7)$$

being $\mathbf{y}_i = \mathbf{N}_i \mathbf{u}$.

Starting from an initial guess of vector \mathbf{s}^u , the sequence of successive approximations is found solving at each step two linear systems, (3) and (6), where \mathbf{N} and \mathbf{Y} are built from the previous approximations of \mathbf{s}^u and \mathbf{u} .

Obviously the number of equations in system (5) must be greater or equal the overall number of unknowns, i.e. the elements of \mathbf{u} and \mathbf{s}^u . This means that systems (3) and (6) are

overdetermined; solving them in a least square sense makes the algorithm numerically stable [6]. Besides, suitable methods can be adopted to accomplish a reduction of the number of unknowns involved in the iterative process and to speed up the convergence of the algorithm.

Owing to the generality of the devices that can be used as standards, it is difficult to formulate general criteria for evaluating *a priori* the consistence of the calibration, as found in the case of fully known standards [4]. The solution here adopted consists in verifying the choice of the standards and the relative connections by simulation.

III. AN APPLICATION AND SOME EXPERIMENTAL RESULTS

The approach previously described for multiport NWA calibration allows to introduce new standard devices which cannot be used with the traditional two-port calibration techniques.

For instance, the classical TRL-LRM algorithms [7] involve the insertion of an unknown one-port reflective standard at both ports of the NWA. With the technique here presented it is possible to extend this idea to the multiport case, in order to use generic p -ports standard devices, *fully unknown*, connected to different combinations of ports.

As an example, the calibration of an N port non-leaky NWA can be carried out by the following set of standard devices:

- *three* different, perfectly known, one-port standard, all connected at the same port of the NWA (for instance, port 1);
- *one fully unknown*, two-port network, connected between N couple of ports, chosen to include each port at least once.

A rough knowledge of the scattering parameters of the unknown standard is actually required as the initial guess for the iterative algorithm.

We applied this technique to the case of a 3-port NWA. The experimental results were obtained on the three-port test-set described in [3,4]. The same multiport NWA was calibrated by the technique here proposed and the algorithm described in [3]. A 10 cm air line was used as verification device.

Figure 2 shows the scattering parameters of the line connected between port 2 and port 3. Note that no fully known standard was connected to these ports during the calibration. Figure 3 shows the S-parameters of a 6-16 GHz 10 dB directional coupler, connected to the NWA as shown in figure 3b. Directivity, isolation and tracking shows excellent agreement between the two calibrations.

IV. CONCLUSION

A new approach to the multiport self-calibration problem was presented. With the described method it is possible to calibrate a MNWA by measuring generic standard devices on which a minimum amount of information is available. This approach is helpful to meet the user needs when the constraints of the test-set environment imposes severe limitations to the kind of standards that can be used. As an example, we calibrated a three port NWA by the insertion of three known reflections at one port of the test set, plus one fully unknown two-port device connected between three couple of ports. The accuracy reached by this calibration is verified by experimental results with respect to a traditional multiport algorithm which uses only fully known standards.

REFERENCES

- [1] N.R.Franzen and R.A.Speciale, "Super-TSD. A generalization of the TSD network analyzer calibration procedure, covering n-ports measurements with leakage", *IEEE MTT-S Int. Microwave Symp. Dig. Tech. Papers* (San Diego, CA), June 21-23, 1977, pp.114-117.
- [2] J.C.Tippet and R.A.Speciale, "A rigorous technique for measuring the scattering matrix of a multiport device with a 2-port network analyzer", *IEEE Trans. Microwave Theory Tech.*, vol.30, n.5, pp.661-666, May 1982.
- [3] A.Ferrero, U.Pisani and K.J.Kerwin, "A new implementation of a multiport automatic network analyzer", *IEEE Trans. Microwave Theory Tech.*, vol.40, no.11, pp. 2078-2085, Nov. 1992.
- [4] A.Ferrero, F.Sanpietro and U.Pisani, "Multiport vector network analyzer calibration: a general formulation", *IEEE Trans. Microwave Theory Tech.*, vol.42, no.12, pp. 2455-2461, Dec. 1994.
- [5] A.Ferrero, F.Sanpietro, "A simplified algorithm for leaky network analyzer calibration", *IEEE Microwave Guided Wave Lett.*, vol.5, pp.119-121, Apr. 1995.
- [6] H.Van Hamme and M. Van Den Bossche, "Flexible vector network analyzer calibration with accuracy bounds using an 8-term or a 16-term error correction model", *IEEE Trans. Microwave Theory Tech.*, vol.42, no.6, June 1994.
- [7] H.Eul, B.Schieck, "A generalized theory and new calibration procedures for network analyzer self-calibration", *IEEE Trans. Microwave Theory Tech.*, vol.39, no.4, pp.724-731, Apr. 1991.

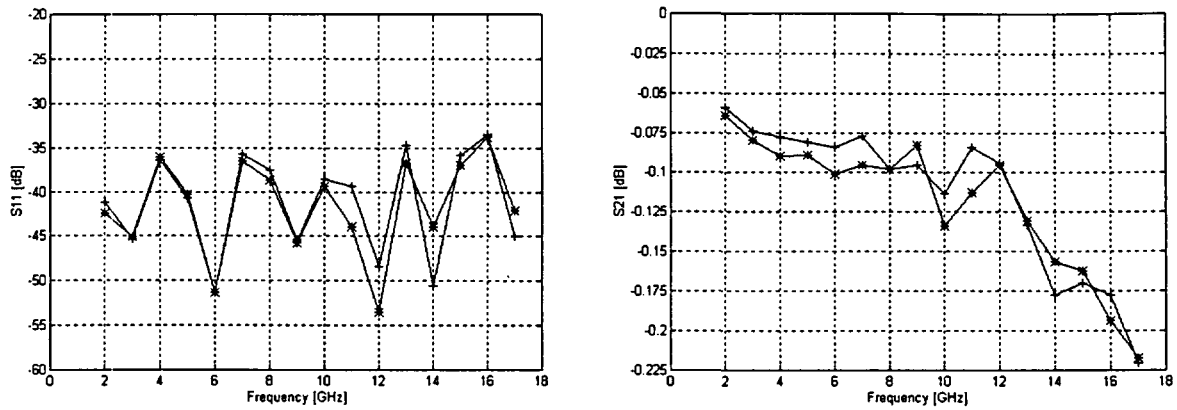

Fig.2. Measurement of a 10 cm verification air line device connected between port 2 and port 3 of a three-port NWA. The S-parameters obtained with the presented technique (plots +) are compared to the data corrected with the algorithm described in [3] (plots *).

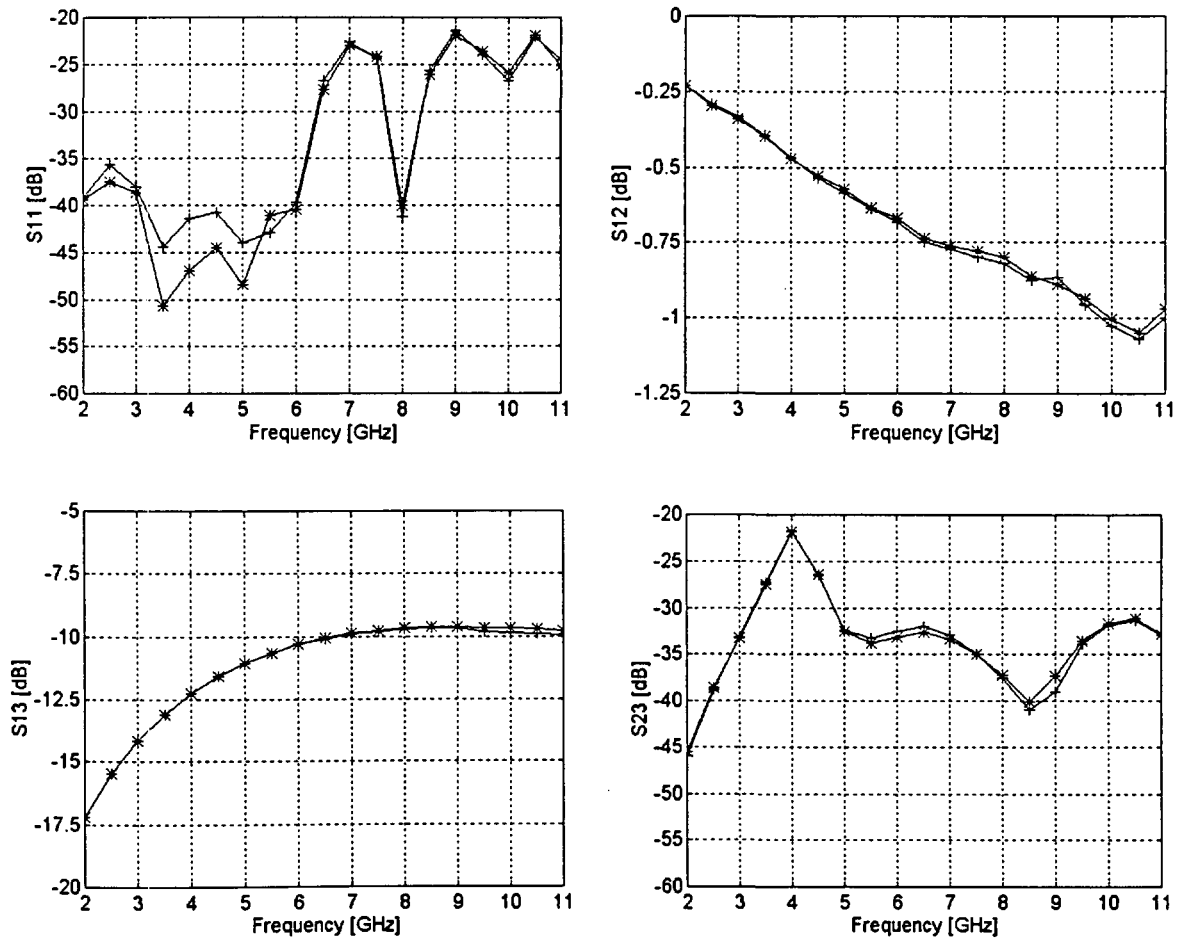

Fig.3. Scattering parameters of a 10dB 6-16GHz directional coupler. The coupled path is port1 - port3. The parameters obtained with the presented technique (plots +) are compared to the data obtained with the algorithm described in [3] (plots *).