

Optical phase-locked loop for coherent detection optical receiver

Original

Optical phase-locked loop for coherent detection optical receiver / S., Camatel; Ferrero, Valter; Gaudino, Roberto; Poggiolini, Pierluigi. - In: ELECTRONICS LETTERS. - ISSN 0013-5194. - STAMPA. - 40:6(2004), pp. 384-385. [10.1049/el:20040264]

Availability:

This version is available at: 11583/1403869 since:

Publisher:

The Institution of Electrical Engineers (IEE)

Published

DOI:10.1049/el:20040264

Terms of use:

This article is made available under terms and conditions as specified in the corresponding bibliographic description in the repository

Publisher copyright

(Article begins on next page)

Optical phase-locked loop for coherent detection optical receiver

S. Camatel, V. Ferrero, R. Gaudino and P. Poggiolini

A novel subcarrier-based optical phase-locked loop (SC-OPLL[®]), with off-the-shelf optical components, is presented and demonstrated. The method, based on a continuous-wave laser and optical subcarrier modulation using a standard LiNbO₃ Mach-Zehnder modulator, allows easier practical implementation than the previously proposed OPLL circuits based on laser direct modulation.

Introduction: Optical phase-locked loops (OPLLs) for homodyne or heterodyne coherent detection received a great deal of attention at the beginning of the 1990s [1, 2] in order to increase the receiver sensitivity, but they never found practical applications, first because of their complexity, secondly due to the introduction of EDFAs, that greatly leveraged sensitivity issues. In the near future, however, coherent detection may come again to the forefront in scenarios such as: multilevel optical phase modulation (*N*-PSK), dispersion compensation in the electrical domain, ultra-dense WDM, fast reconfigurable optical networks, optical sensors, microwave photonics, etc.

The previously proposed OPLLs were based on *fast* direct laser frequency tuning, and required complex/expensive optoelectronic devices, such as solid-state lasers [1], wide-bandwidth electrical PLL circuits and piezoelectrically controlled narrow optical filters [2], multi-section DFBs and external cavity lasers with *fast* direct laser frequency tuning [1], an acoustic optical modulator with limited tunable frequency range (~10 MHz), and an additional *fast* frequency control unit for the external cavity laser in order to increase the frequency range (several hundred MHz) [3].

In this Letter, we propose and experimentally demonstrate a novel and much simpler OPLL architecture based on commercial off-the-shelf optoelectronic components and without *fast* direct laser frequency tuning. Frequency tuning is obtained in our system through optical subcarrier (SC) generation and tuning, and will be indicated as SC-OPLL[®] (patent pending).

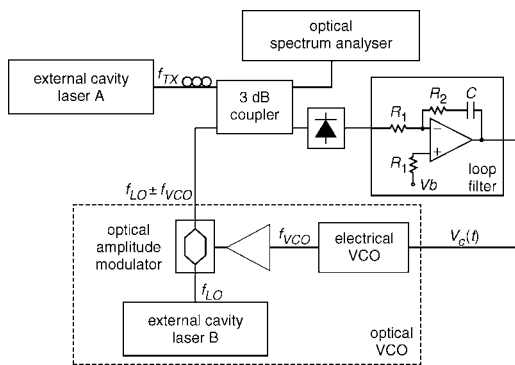

Fig. 1 Schematic diagram of proposed SC-OPLL[®]

Architecture: The SC-OPLL[®] architecture is shown in Fig. 1. The optical voltage controlled oscillator (OVCO) is the key element and is based on a commercial continuous-wave (CW) external cavity tunable laser at frequency f_{LO} , that is externally amplitude modulated by the signal coming from an electrical VCO at frequency f_{VCO} . By biasing the external Mach-Zehnder (MZ) amplitude modulator at a null of its transfer function, a sinusoidal carrier-suppressed modulation is obtained. The resulting spectrum at the output of the OVCO is shown in Fig. 2a. Two main SCs at frequency $f_{LO} \pm f_{VCO}$ are generated, with spurious optical tones at f_{LO} and $f_{LO} \pm 2f_{VCO}$. Using one of the two main SCs, e.g. the one at $f_{LO} + f_{VCO}$, we are able to tune an optical frequency by simply changing the voltage applied to the electrical VCO, thus implementing an OVCO. This is the key issue of the proposed architecture, that allows obtaining optical fine frequency tuning with the speed and stability of an electrical VCO, and thus to reuse typical RF PLL setups. In our case, a standard second-order PLL control circuit allows locking $f_{LO} + f_{VCO}$ to the transmitted signal at frequency f_{TX} (laser A in Fig. 1). When the OPLL is locked to $f_{LO} + f_{VCO} = f_{TX}$, optical homodyne is obtained, allowing tracking of the incoming optical signal frequency and phase.

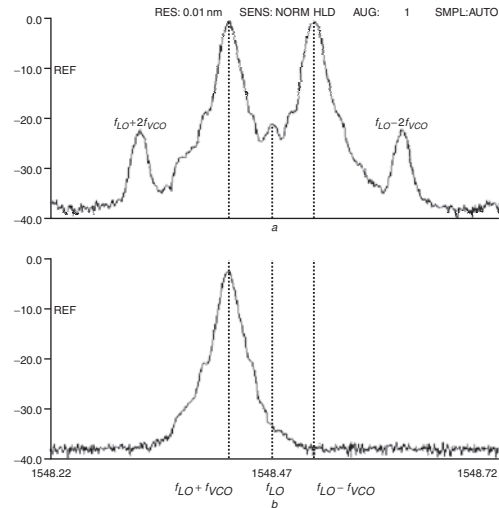

Fig. 2 OVCO output and RX signal optical spectra when two signals phase-locked

a OVCO output b RX signal
Resolution bandwidth 0.01 nm; y-axis: unit [dBm], 5 dB/div; x-axis: unit [nm], 0.05 nm/div.

When the incoming signal is modulated, its optical spectrum is translated to baseband at the photodiode output. In principle, due to beating with the other SCs, copies of this signal appears also around frequencies f_{VCO} and $2 \cdot f_{VCO}$, but they can be filtered out by the receiver filter, provided that f_{VCO} is larger than the signal spectral width (or bandwidth). Other details of the setup can be found in Fig. 1. An active polarisation controller matches the polarisation of TX and LO signals before being combined by a 3 dB coupler and sent to an amplified photodiode. The resulting electrical signal is processed by a single-pole active filter, in order to obtain a second-order PLL with natural frequency f_{loop} and damping factor ζ [4], which both depend on the loop filter parameters $\tau_1 = R_1 C$ and $\tau_2 = R_2 C$.

Experimental results: To demonstrate the performance of the OPLL, we implemented the architecture shown in Fig. 1 using two 1550 nm commercial external cavity tunable lasers (having a declared linewidth less than 100 kHz), an electrical VCO with 100 MHz/V tuning coefficient and 6.2 GHz central frequency, and a 10 GHz LiNbO₃ amplitude modulator. We obtained coarse (and *slow*) optical frequency tuning by changing the external cavity CW frequency, while fine (and *fast*) frequency tuning (i.e. phase locking) was obtained through our SC-OPLL[®] principle. Using the phase-error estimation technique described in [1], we measured the root mean square (rms) phase error of the OPLL when locked to a CW optical signal. Fig. 3 shows the OPLL phase error against f_{loop} (which was varied by changing the loop filter parameters while keeping $\zeta = 0.7$). The minimum phase error is around 5° rms, and was obtained for $f_{loop} \simeq 4$ MHz. We verified by numerical simulation that the OPLL had a phase error close to the theoretical one, which is limited only by the intrinsic linewidth of the used optical sources. A 5° rms phase error is perfectly acceptable for coherent transmission, i.e. it gives less than 0.1 dB penalty in a 2-PSK system [4]. The measurement was then repeated by adding ASE noise to the TX signal. In Fig. 3, we show the results for an OSNR equal to 5 dB (on 0.1 nm bandwidth). The phase-error penalty with respect to the noiseless case is still small (phase error 6° rms), demonstrating the OPLL rejection of extremely high ASE noise levels. To further check the system performance, we ran an On-Off transmission experiment. The experiment was performed at 2.5 Gbit/s, using a standard setup for the transmitter side (NRZ-OOK, 2²³-1 PRBS, external modulation) and an SC-OPLL[®] coherent homodyne receiver. The resulting optical spectra are shown in Fig. 2. In this setup, the SC-OPLL tracks the phase of the NRZ signal, thus allowing coherent homodyne detection [1]. To this end, we have substituted the coupler in Fig. 1 with a 90° optical hybrid [5]. The resulting BER against the received signal OSNR (defined over 0.1 nm bandwidth), is shown in Fig. 4. We compared the performance of a standard direct detection (DD) receiver to the performance of the homodyne receiver, in the two conditions $f_{loop} = 4$ MHz (optimum

value, see Fig. 3) and 1.6 MHz. For the optimised configuration ($f_{loop} = 4$ MHz), the homodyne detection shows approximately 1 dB advantage over the DD, which is very close to the theoretical value [4]. This result confirms that our setup performance is very close to an ideal homodyne receiver. We also verified that when f_{loop} is set to 1.6 MHz, i.e. very far from its optimum, the performance is affected by a large phase error ($\approx 10^\circ$ rms), thus generating an expected BER floor [4].

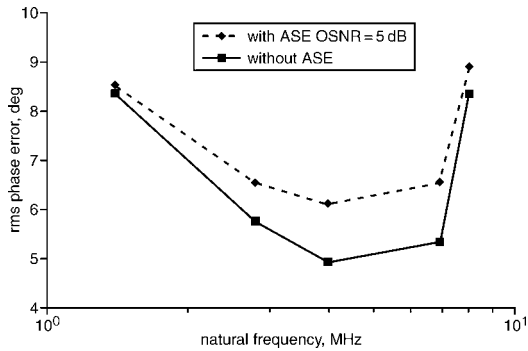

Fig. 3 OPLL RMS phase error against loop natural frequency

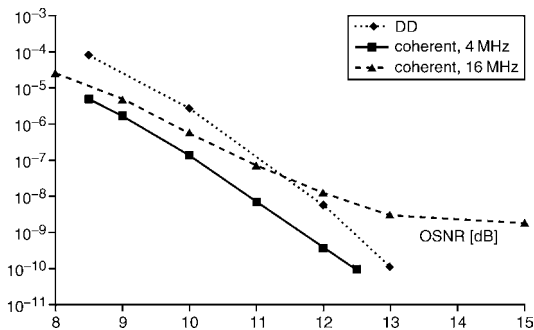

Fig. 4 BER against OSNR for reference standard direct detection receiver, and for homodyne receiver with loop natural frequency set to 4 and 1.6 MHz

Conclusion: We have experimentally demonstrated a novel SC-OPLL[®] based on off-the-shelf optoelectronic components. We believe that the proposed architecture, owing to its simplicity and stability, can be effective in next-generation optical transmission systems.

Acknowledgment: This project was funded by CISCO, University Research Program (URP).

© IEE 2004

9 January 2004

Electronics Letters online no: 20040264

doi: 10.1049/el:20040264

S. Camatel, V. Ferrero, R. Gaudino and P. Poggiolini (Dipartimento di Elettronica, Politecnico di Torino, corso Duca degli Abruzzi, 24, 10129 Torino, Italy)

References

- 1 Kazovsky, L.G., and Atlas, D.A.: 'A 1320-nm experimental optical phase-locked loop: performance investigation and PSK homodyne experiments at 140 Mbps and 2 Gbps', *J. Lightwave Technol.*, 1990, **8**, pp. 1414–1425
- 2 Kourogi, M., Shin, C., and Oshu, M.: 'A 134 MHz bandwidth homodyne optical phase-locked-loop of semiconductor laser diodes', *IEEE Photonics Technol. Lett.*, 1991, **3**, pp. 270–272
- 3 Fisher, G.: 'A 700 Mbit/s PSK optical homodyne system with balanced phase locked loop', *J. Opt. Commun.*, 1988, **9**, pp. 27–28
- 4 Kazovsky, L.G., Benedetto, S., and Willner, A.: 'Optical fiber communication systems' (Artech House, 1996)
- 5 Leeb, W.R.: 'Optical 90 degrees hybrid for Costas-type receivers', *Electron. Lett.*, 1990, **26**, (18), pp. 1431–1432