

An empirical investigation of learning curve composition laws for quality improvement in complex manufacturing plans

*Original*

An empirical investigation of learning curve composition laws for quality improvement in complex manufacturing plans / Franceschini, Fiorenzo; Galetto, Maurizio. - In: JOURNAL OF MANUFACTURING TECHNOLOGY MANAGEMENT. - ISSN 1741-038X. - STAMPA. - 15, n.7:(2004), pp. 687-699. [10.1108/17410380410555925]

*Availability:*

This version is available at: 11583/1400183 since:

*Publisher:*

Emerald

*Published*

DOI:10.1108/17410380410555925

*Terms of use:*

This article is made available under terms and conditions as specified in the corresponding bibliographic description in the repository

*Publisher copyright*

(Article begins on next page)

---

# An empirical investigation of learning curve composition laws for quality improvement in complex manufacturing plants

---

*Fiorenzo Franceschini and  
Maurizio Galetto*

---

## The authors

Fiorenzo Franceschini is Professor and Maurizio Galetto is Assistant Professor, both based in the Dipartimento di Sistemi di Produzione ed Economia dell'Azienda, Politecnico di Torino, Torino, Italy.

---

## Keywords

Learning curves, Quality improvement, Manufacturing systems, Plant efficiency

---

## Abstract

Learning behaviors related to quality improvement in manufacturing systems (i.e. reduction of defectiveness over production cycles) are widely investigated. Many different approaches have been introduced to describe the link between the learning mechanism and quality performance of a plant. In a previous study by the same authors, a set of learning "composition laws" for two basic structures were defined to provide a tool to forecast the behavior of complex manufacturing systems composed by a network of elementary processes. This paper presents an empirical investigation about these learning composition laws on a real case in the field of automotive exhaust-systems manufacturing.

## 1. Introduction

Learning curves describe the evolution of manufacturing systems over time. They can be used to represent the behavior of defectiveness or labor hours as experience is gained.

It has been proved that as the experience increases with the production of a particular product – either by a single worker or by an industry as a whole – the production process becomes more efficient (Cherrington *et al.*, 1987; Franceschini, 2002; Franceschini and Galetto, 2002; Schneiderman, 1988). As manufacturing cycles or production output go on, the "system" increases its degree of knowledge, so as to ensure shorter production cycles, a smaller defectiveness or a larger production output.

Analyzing the relationship between the process efficiency and the cumulative number of production cycles, management can accurately predict the real capacity of existing facilities and the unit cost of production. Today, we recognize that many other factors, besides the improving skill of individual workers, contribute to this fact. Some of these include an improvement of production methods, the reliability and efficiency of the equipments and machines used, a better product design, an improved production scheduling and inventory control, and finally a better organization of the workplace.

The first attempt to scientifically analyze the learning phenomenon was focused on human subjects behavior and dates to the end of the 19th century (Thorndike, 1898; Thurstone, 1919). These researchers showed that the time required for executing a specific operation decreased as the experience gathered increased. The authors defined "experience curve" to be the behavior of this labor time. Afterwards, an analogous experience was observed in industrial organizations – especially in manufacturing systems. The term "learning curve" was then defined (Yelle, 1979).

The first written document dealing with a manufacturing process was published by Wright (1936), who observed that in aircraft production the labor-time units in input was decreasing as a function of cumulative output. Later on, many other researchers dedicated their studies to the application of learning curves in different industrial sectors. In this paper, we refer to

---

The authors wish to thank Magneti Marelli (Powertrain Systems, Sistemi di Scarico, Italy) for the useful and continuous support given during the research development.

“learning” as the ability of reducing defectiveness over production cycles, adopting the logic of Process Quality Improvement.

Theories attempting to describe the learning curve for a manufacturing process were developed by Crossman (1959), Levy (1965), Muth (1986), Roberts (1983), Sahal (1979), Venezia (1985) and Zangwill and Kantor (1998). Experimental analyses were proposed by Bailey and McIntyre (1997), Cherrington *et al.* (1987), Laprè *et al.* (2000) and Schneiderman (1988). Many different learning models were proposed. The most common ones are the exponential and the power models, which are applied in a wide variety of applicative fields (Muth, 1986).

Nowadays, the study and the analysis of learning curves are still ongoing. Many important reasons lead researchers to focus their attention on this subject. A specific interest is devoted to the time factor, which is a more competitive aspect in the study and development of new products or manufacturing systems.

The knowledge of learning curves can be helpful in many cases: to predict the full working time of a process, to fix factory incentives or production objectives or to define the asymptotic defectiveness of a plant.

The predictive element is very important, especially in the early phases of setting up a new plant. This element must be supported by good predictive algorithms which consider all the factors affecting a complex manufacturing system (Naim, 1993).

With regard to the last issue, once the elementary sub-process learning curves are known, a set of learning “composition laws” can be defined to provide a forecasting tool to foresee the behavior of complex manufacturing systems (Franceschini and Galetto, 2003).

In order to empirically investigate these composition laws, this paper describes the results obtained from an in-depth study conducted on a complex manufacturing plant of automotive exhaust systems. In the first part, the basic approach of the composition laws is recalled. Then, a schematic description of the production process, the methodology used for the experimental investigation and the data collection are also reported. Finally, a statistical analysis and some experimental considerations are discussed.

## 2. Composition laws of elementary process learning curve

Consider a generic manufacturing process. We define the production cycle (cumulative input) of the entire process after the start-up as  $q$ , and

the cumulative number of rejected components as  $D(q)$ . We also define the fraction of cumulative rejected components over cumulative input as  $F(q)$ :

$$F(q) = \frac{D(q)}{q} \quad (1)$$

The theoretical quality improvement (QI) learning curve (defectiveness curve over time) of the whole system can be expressed as follows (Franceschini and Galetto, 2003):

$$L(q) = \frac{dD(q)}{dq} \quad (2a)$$

Furthermore, the QI learning curve for a discrete manufacturing process can be expressed as:

$$L(q) = \frac{\Delta D(q)}{\Delta q} = \frac{D(q+N) - D(q)}{(q+N) - q} \quad (2b)$$

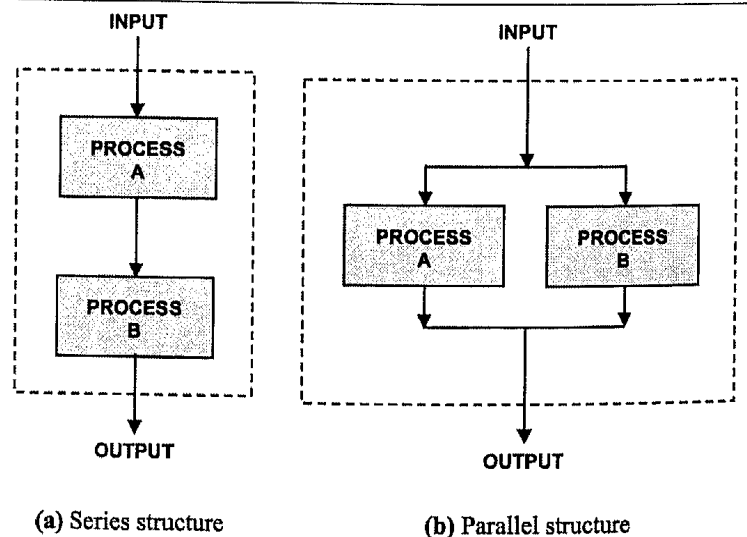
where  $N$  is a well defined number of production cycles (for example, a daily production).

Defining  $D(q)$  as a positive non-decreasing quantity,  $L(q)$  is a positive decreasing function.

Interpreting a complex manufacturing system as a network of elementary processes (elementary blocks) connected to each other by series or parallel structures, and referring to the rate of non-conforming units, we can obtain the whole system QI learning curve by applying the basic composition laws.

Considering two elementary blocks (A and B) connected in a series configuration ( $A \xrightarrow{S} B$ ) (Figure 1(a)), it can be shown that the series-system learning curve ( $L_{eq}(q)$ ) is given by (Franceschini and Galetto, 2003):

Figure 1 Example of a “learning block diagram”



$$L_{eq}(q) = L_A(q) + L_B \{q[1 - F_A(q)]\} - L_A(q)L_B \{q[1 - F_A(q)]\} \quad (3)$$

where  $q$  is the production cycle (cumulative input) of the entire process after the start-up;  $F_A(q) = (D_A(q))/q$  is the fraction of rejected components at the  $q$ th cycle by process A;  $L_A(q) = (dD_A(q))/dq$  is the process A learning curve at the  $q$ th cycle and  $L_B(q) = (dD_B(q))/dq$  is the process B learning curve at the  $q$ th cycle.

For two elementary blocks (A and B) connected in a parallel configuration (A||B) (Figure 1(b)), it can be shown that the parallel-system learning curve is given by (Franceschini and Galetto, 2003):

$$L_{eq}(q) = \frac{f}{1+f} L_A \left( q \frac{f}{1+f} \right) + \frac{1}{1+f} L_B \left( q \frac{1}{1+f} \right) \quad (4)$$

where  $f = q_A/q_B$  is the “capacity parameter”,  $q_A$  is the number of components worked by process A and  $q_B$  is the number of components worked by process B.

It must be noted that only similar processes can give rise to a parallel structure. We define two processes which produce a “similar” part or component. If the two processes are not similar, the situation becomes more complex. For example, consider two processes which produce two different components, that are assembled together in a successive step. The defectiveness of the whole equivalent system is obtained by combining the defectiveness of the successive phase with that of the maximum of the two parallel branches. In this case, the two parallel processes should be considered as a unique equivalent process with a learning curve equal to the maximum of the two.

An experimental validation of these composition laws was performed by analyzing the initial production phases of a new automotive exhaust-systems manufacturing plant.

### 3. Process description

The study was conducted on an automotive exhaust-systems production plant of a well-known international company (Magneti Marelli, Powertrain Systems, Sistemi di Scarico, Italy). The analysis involved the launching phase of a manufacturing line of a complete exhaust-system of a new automobile model.

The process monitoring period was two working months. We considered two motorizations that – according to the learning curve theory – can be considered as two equivalent manufacturing systems: “motorization  $\alpha$ ” and “motorization  $\beta$ ”.

A complete exhaust-system is constituted by a front, a central and a rear pipe (Figure 2).

- The front pipe is connected to the engine by a collector, which is followed by a box containing a monolith and on which a lambda probe is connected; the lambda probe is positioned on the output pipe.
- The central pipe is composed of a flexible pipe, a central tube and a central body.
- The rear pipe is made up of an input pipe, a rear body (also called exhaust box) and an exhaust pipe.

The three components of the whole exhaust-system are welded together.

The production flow, which was similar for the two motorizations, can be represented using the following functional macro-phases. Figure 3 shows their connections. Each phase may include one or more working stations identified by a progressive numeration from 1 to 14.

- Phase A – flange welding to the exhaust pipe (station 3);
- Phase B – monolith assembling (station 5), lambda probe welding (station 4), monolith and output system assembling (station 6);
- Phase C – collector and heat protections welding (station 7), airtight test (station 8);
- Phase D – central bodies preparation (station 1), input pipe assembling and welding to the central body (station 9), flexible pipe welding to the input tube (station 10);
- Phase E – rear bodies preparation (station 2), output pipe and stirrup welding to the rear body (station 11), final little pipe welding (station 12);
- Phase F – front pipe and rear pipe assembling (station 13), airtight test and retouches (station 14).

After each phase a quality control was performed in order to individuate and reject the defective units.

Figure 4 shows the process diagram from the learning point of view. Interpreting each phase as an elementary block, the whole process can be thought of as composed of two parallel branches. The left branch consists of the series structure of phases A, B and C; and the right branch of phases D and E.

Figure 2 Scheme of a complete automotive exhaust-system

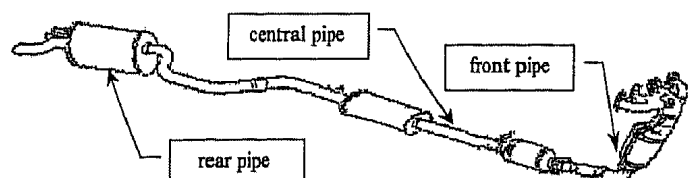
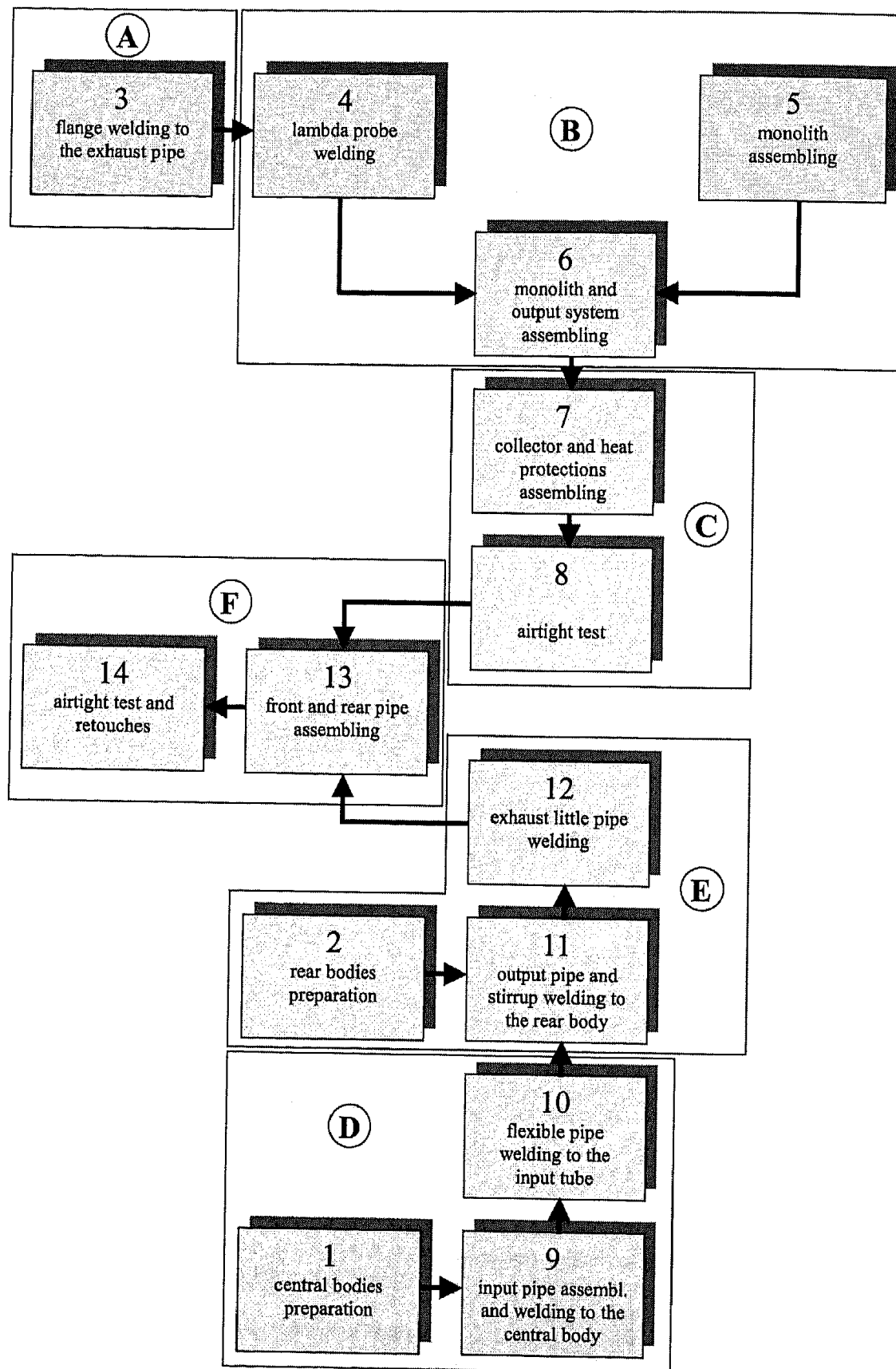
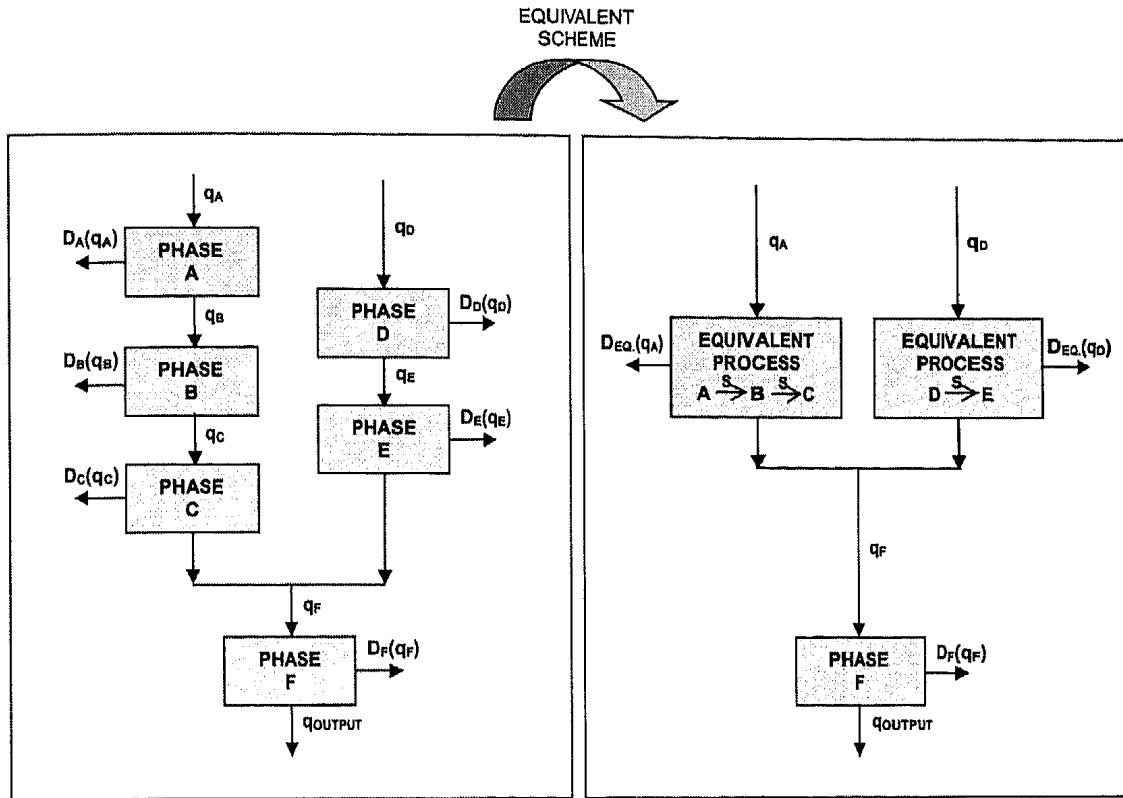


Figure 3 Scheme of the production flow of a complete automotive exhaust-system manufacturing line



Note: Each macro-phase includes one or more working stations identified by a progressive numeration from 1 to 14. Motorizations  $\alpha$  and  $\beta$  adopted the same production flow

Figure 4 Schematic diagram of the manufacturing system for the production of a complete automotive exhaust-system



Note: The learning curve of the whole equivalent system is obtained by considering the maximum learning curve of the two branches (A, B and C phase series) and (D and E phase series)

Note that the two parallel branches do not represent similar processes. Therefore, the learning curve of the equivalent system cannot be obtained using the parallel composition law. As discussed in the previous section, it is given by the “maximum learning curve” of the two parallel branches.

#### 4. Data collection

Motorizations  $\alpha$  and  $\beta$  were developed on twin plants that had the same kind of equipment, procedures and quality control methods. The nominal daily productions were 360 and 240 units for the motorizations  $\alpha$  and  $\beta$ , respectively.

Beginning from the launch of production, the two lines were monitored daily for two working months. At the end of each month, to summarize the daily collected data, a technical report was produced.

The number of defective units was recorded and analyzed for each macro-phase of both lines. The cumulative number of rejected components  $D(q)$ , the fraction of cumulative rejected components  $F(q)$  and of the QI learning curve  $L(q)$  were calculated as follows:

$$F(q_i) = \frac{D(q_i)}{q_i} \quad (5)$$

and

$$\begin{aligned} L(q_i) &= \frac{\Delta D(q_i)}{\Delta q_i} = \frac{D(q_i) - D(q_{i-1})}{q_i - q_{i-1}} \\ &= \frac{D(q_{i-1} + N) - D(q_{i-1})}{(q_{i-1} + N) - q_{i-1}} \\ &= \frac{D(q_{i-1} + N) - D(q_{i-1})}{N} \end{aligned} \quad (6)$$

where  $i$  is the day index ( $i = 1$  for the first day,  $i = 2$  for the second and so on);  $N$  is the daily production ( $N = 360$  and  $240$  for motorizations  $\alpha$  and  $\beta$ , respectively).

Tables I and II and Figures 5 and 6 show the synthesis of the overall gathered data for the two motorizations. Figure 7 gives a detailed manufacturing diagram of the motorization  $\alpha$  for the first production day.

$L(q)$  of the motorization  $\alpha$  demonstrates a regular behavior, while motorization  $\beta$  suffers some perturbations in the initial learning period. However, it is important to stress the fact that from a plant designer’s point of view, the crucial factor is the learning average asymptotic behavior rather than the early punctual oscillations.

Table I Experimental gathered data for the motorization  $\alpha$  during a period of two working months

Day ( <i>i</i> )	$q_i$	Motorization $\alpha$						
		$\Delta D_{eq}(q_i)$	$\Delta D_A(q_i)$	$\Delta D_B(q_i)$	$\Delta D_C(q_i)$	$\Delta D_D(q_i)$	$\Delta D_E(q_i)$	$\Delta D_F(q_i)$
1 September	360	184	11	14	12	47	51	86
2 September	720	95	8	10	6	20	24	51
3 September	1,080	116	0	4	0	13	31	72
6 September	1,440	87	1	9	9	11	21	55
7 September	1,800	60	0	7	0	7	15	38
8 September	2,160	31	0	0	0	6	7	18
9 September	2,520	32	0	0	0	4	7	21
10 September	2,880	26	0	0	0	5	13	8
13 September	3,240	26	0	0	0	3	12	11
14 September	3,600	17	0	0	0	3	7	7
15 September	3,960	17	0	0	0	2	7	8
16 September	4,320	11	0	0	0	3	3	5
17 September	4,680	16	0	0	0	1	6	9
20 September	5,040	24	0	0	0	7	6	11
21 September	5,400	12	0	0	0	2	4	6
22 September	5,760	9	0	0	0	1	4	4
23 September	6,120	7	0	0	0	2	3	2
24 September	6,480	12	0	0	0	1	5	6
27 September	6,840	17	0	0	0	3	3	11
28 September	7,200	18	0	0	0	3	8	7
29 September	7,560	11	0	0	0	1	4	6
30 September	7,920	6	0	0	0	2	1	3
4 October	8,280	4	0	0	0	1	1	2
5 October	8,640	13	0	0	0	1	2	10
6 October	9,000	5	0	0	0	0	1	4
7 October	9,360	12	0	0	0	2	4	6
8 October	9,720	8	0	0	0	1	2	5
11 October	10,080	3	0	0	0	0	1	2
12 October	10,440	8	0	0	0	1	2	5
13 October	10,800	4	0	0	0	0	1	3
14 October	11,160	4	0	0	0	1	1	2
15 October	11,520	10	0	0	0	1	5	4
18 October	11,880	6	0	0	0	2	1	3
19 October	12,240	2	0	0	0	0	0	2
20 October	12,600	5	0	0	0	1	1	3
21 October	12,960	2	0	0	0	0	0	2
22 October	13,320	3	0	0	0	0	1	2

Note: The daily production was 360 units/day.  $\Delta D(q_i)$  represents the daily rejected components by each working phase

## 5. Data analysis

As a first step, each macro-phase (elementary block) of the motorization  $\alpha$  was analyzed. Assuming a normal distribution for the statistical errors of each level  $L(q_i)$ , the corresponding learning curve with the related confidence bands was estimated by a non-linear regression of the experimental data (Seber and Wild, 1989). The selected model for the analysis is the following:

$$L(q) = L_0 + L_1 e^{-\frac{q}{\tau}} \quad (7)$$

where  $L_0$ ,  $L_1$  and  $\tau$  are specific constants of each single block.

This is a simplified model which works well enough for the validation of the problem at hand

(Bevis *et al.*, 1970). See Naim (1993) for a deeper analysis.

Table III shows the parameter values, and the corresponding standard deviations, obtained for each macro-phase. Afterwards, by applying the described compositions laws (Section 2), the global learning curve of the motorization  $\alpha$  was calculated.

As previously noted, it must be pointed out that the two parallel branches do not represent similar processes. The learning curve of the equivalent system is given by the maximum of the two. According to the experimental results, the upper curve represents the right branch of Figure 4 (D and E macro-phases), as clearly shown in Figure 8. Therefore, the equivalent learning

Table II Experimental gathered data for the motorization  $\beta$  during a period of two working months

Day ( <i>i</i> )	$q_i$	Motorization $\beta$						
		$\Delta D_{eq}(q_i)$	$\Delta D_A(q_i)$	$\Delta D_B(q_i)$	$\Delta D_C(q_i)$	$\Delta D_D(q_i)$	$\Delta D_E(q_i)$	$\Delta D_F(q_i)$
1 September	240	110	4	7	0	9	101	0
2 September	480	40	2	12	3	0	0	40
3 September	720	99	0	0	0	0	51	48
6 September	960	63	0	0	0	22	31	10
7 September	1,200	50	0	0	0	28	22	0
8 September	1,440	44	0	0	19	0	44	0
9 September	1,680	17	0	0	0	12	5	0
10 September	1,920	31	0	0	0	0	31	0
13 September	2,160	6	0	12	0	0	6	0
14 September	2,400	3	0	0	3	0	0	3
15 September	2,640	12	0	0	0	0	6	6
16 September	2,880	7	0	0	0	0	0	7
17 September	3,120	11	0	0	0	11	0	0
20 September	3,360	4	0	0	0	0	0	4
21 September	3,600	12	0	0	2	0	12	0
22 September	3,840	5	0	0	0	0	5	0
23 September	4,080	5	0	0	0	0	5	0
24 September	4,320	4	0	0	0	0	4	0
27 September	4,560	3	0	0	0	0	0	3
28 September	4,800	10	0	0	0	0	8	2
29 September	5,040	3	0	0	0	3	0	0
30 September	5,280	4	0	0	0	0	4	0
4 October	5,520	2	0	0	0	2	0	0
5 October	5,760	11	0	0	0	0	0	11
6 October	6,000	4	0	0	0	4	0	0
7 October	6,240	8	0	0	0	0	8	0
8 October	6,480	4	0	0	0	0	0	4
11 October	6,720	7	0	0	0	0	0	7
12 October	6,960	2	0	0	0	0	2	0
13 October	7,200	6	0	0	0	6	0	0
14 October	7,440	0	0	0	0	0	0	0
15 October	7,680	4	0	0	0	0	4	0
18 October	7,920	10	0	0	0	0	0	10
19 October	8,160	2	0	0	0	0	0	2
20 October	8,400	3	0	0	0	0	0	3
21 October	8,640	0	0	0	0	0	0	0
22 October	8,880	2	0	0	0	2	0	0

Note: The daily production was 240 units/day.  $\Delta D(q_i)$  represents the daily rejected components by each working phase

curve of the entire production system is given by the series structure of macro-phases D, E and F.

Assuming that there is no correlation between each single block, the corresponding confidence interval can be obtained by the following variance composition equation (Box *et al.*, 1978; Montgomery, 2000):

$$\sigma_{L_{eq}} = \sqrt{\sum_{j=1}^n \left( \frac{\partial L_{eq}}{\partial L_j} \right)^2 \sigma_{L_j}^2} \quad (8)$$

where  $L_{eq}$  is the equivalent learning curve;  $\sigma_{L_{eq}}$  is the equivalent learning curve standard deviation;  $L_j$  is the  $j$ th block learning curve and  $\sigma_{L_j}$  is the  $j$ th block learning curve standard deviation.

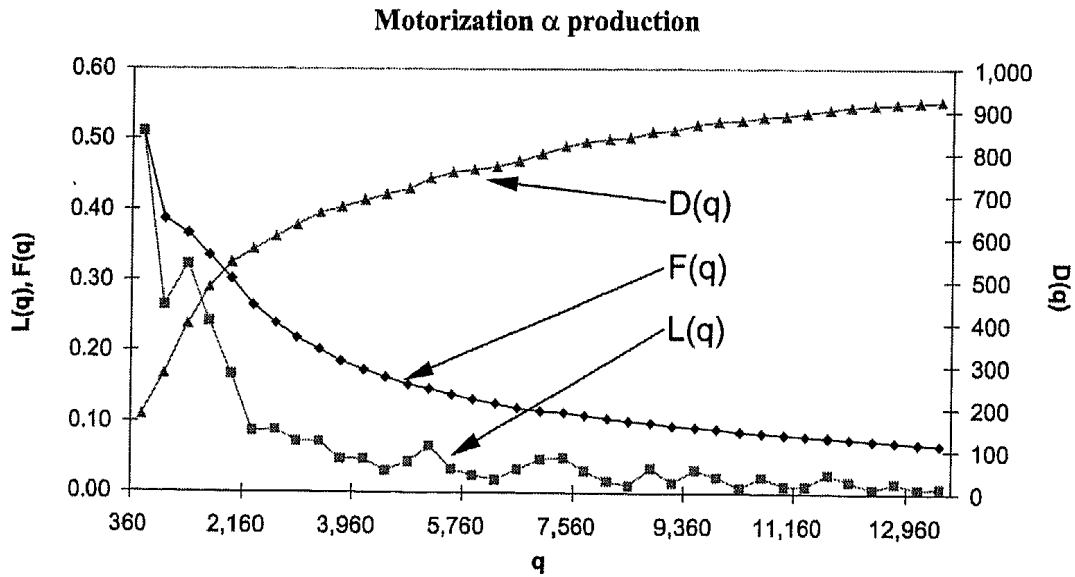
Figure 9 shows the collected experimental data, and the composed learning curve for the whole motorization  $\alpha$  production system, with the corresponding 95 per cent confidence interval on a single observation (Seber and Wild, 1989). Except for the second point in the early monitoring, all data are included in the confidence interval.

The main characteristic of the composition method is related to its capability to provide a preliminary forecast of non-conforming units of a complex plant. This information is very helpful during the early design phases, allowing for rationalization of the "process architecture".

This "prediction capability" can be experimentally verified by using the data collected for the motorizations  $\alpha$  and  $\beta$ .

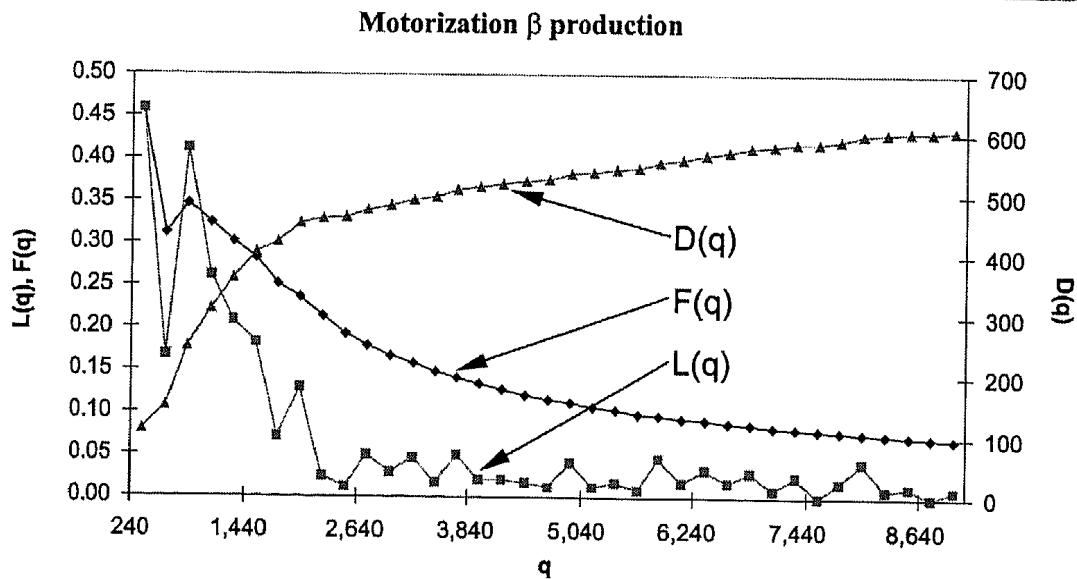


Figure 5 Experimental behavior of  $D(q)$ ,  $F(q)$  and  $L(q)$  for the motorization  $\alpha$



Note: The daily production was 360 units

Figure 6 Experimental behavior of  $D(q)$ ,  $F(q)$  and  $L(q)$  for the motorization  $\beta$



Note: The daily production was 240 units

Since the two motorizations can be considered as two similar plants, it is possible to predict motorization  $\beta$ 's behavior on the basis of motorization  $\alpha$ 's estimated parameters. Therefore, the expected learning curve for the whole production system of the motorization  $\beta$  can be predicted by applying the learning composition laws and the estimated parameters for each single macro-phase of the motorization  $\alpha$ .

The first step of the procedure attributes the corresponding learning curves of motorization  $\alpha$  to each macro-phase of motorization  $\beta$  (Table III). Once the average daily production is defined (i.e. 240 units), we are able to estimate the

expected rejected quantities ( $\Delta D(q_i)$ ) by each production phase over time (number of production cycles). Table IV shows the forecasts of the model after 5, 15, 25 and 35 working days.

In the second step, by applying the learning composition laws (Figure 10), the expected learning curve for the whole production system of the motorization  $\beta$  is obtained. Furthermore, such as for every single macro-phase, it is possible to estimate the expected rejected quantity ( $\Delta D(q_i)$ ) by the whole production plant (Table IV).

At this point, we can compare the asymptotical values of the obtained learning curve for the motorization  $\beta$  with the corresponding

Figure 7 Manufacturing diagram of the first production day for the motorization  $\alpha$  (see also Table I)

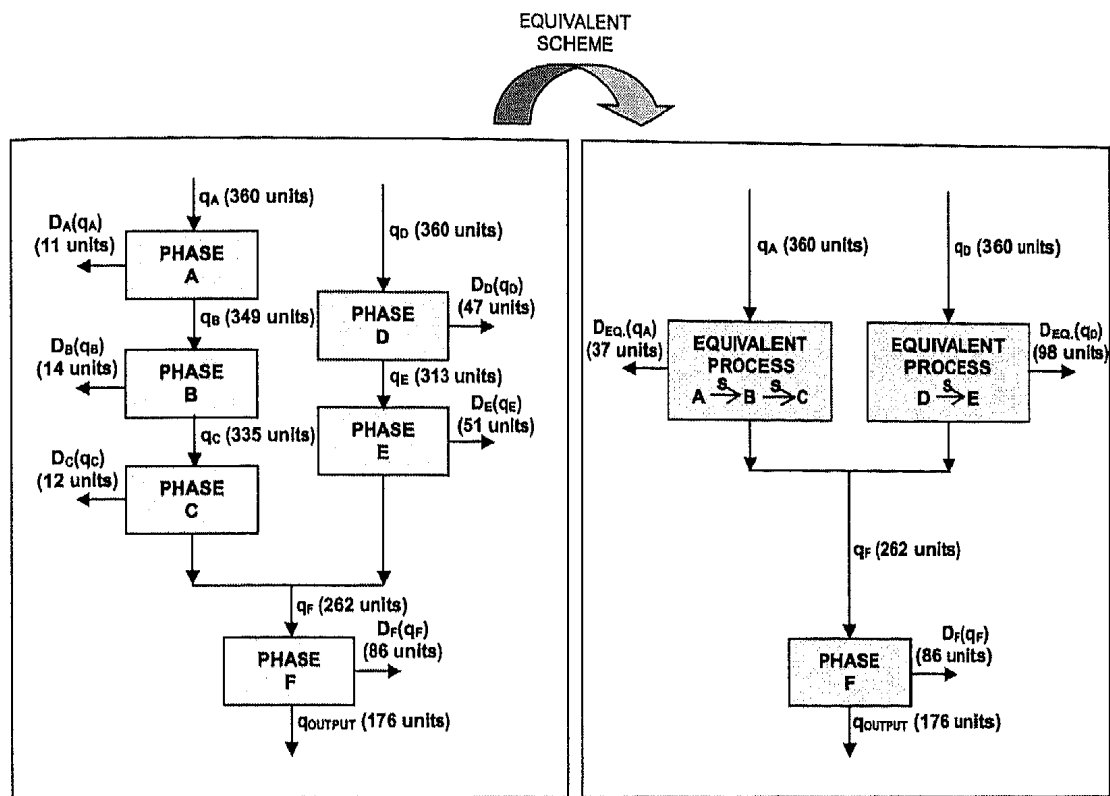


Table III Parameter values and standard deviations obtained by a non-linear regression of the experimental data for each macro-phase

Macro-phase	Motorization $\alpha$						
	$L_0$	$L_0$ Standard deviation	$L_1$	$L_1$ Standard deviation	$\tau$ (cycle $^{-1}$ )	$\tau$ Standard deviation (cycle $^{-1}$ )	
A	$0.0 \times 10^{-4}$	$3.2 \times 10^{-4}$	0.070	0.008	466	52	
B	$0.0 \times 10^{-4}$	$6.6 \times 10^{-4}$	0.057	0.006	998	135	
C	$0.0 \times 10^{-4}$	$7.2 \times 10^{-4}$	0.058	0.011	620	132	
D	$50.1 \times 10^{-4}$	$9.1 \times 10^{-4}$	0.229	0.018	559	45	
E	$8.1 \times 10^{-3}$	$2.0 \times 10^{-3}$	0.186	0.016	1,013	118	
F	$11.2 \times 10^{-3}$	$3.8 \times 10^{-3}$	0.378	0.025	1,095	108	

experimental data (Table II). Except the early production periods, the experimental observations match the predicted ones.

The set of points falling out of the confidence interval is probably due to the production system settlements that heavily influence the early learning process. As soon as the production goes on, the asymptotical behavior of experimental points follows the prediction values. Figure 10 shows the collected experimental data and the expected learning curve for the motorization  $\beta$  with the corresponding 95 per cent confidence interval on a single observation.

A practical comparison between the expected learning curve for the whole production system of the motorization  $\beta$  (obtained by applying the composition laws and the estimated parameters of the motorization  $\alpha$ ) and the curve obtained by the overall experimental data, can be executed by means of a hypothesis test. Introduce a new

variable  $\Delta(q)$ , which represents the local difference between the predicted learning curve value and the corresponding experimental observation (at  $q$ -th production cycle):

$$\Delta(q) = L_{eq}(q) - L_{exp}(q), \quad \forall q \quad (9)$$

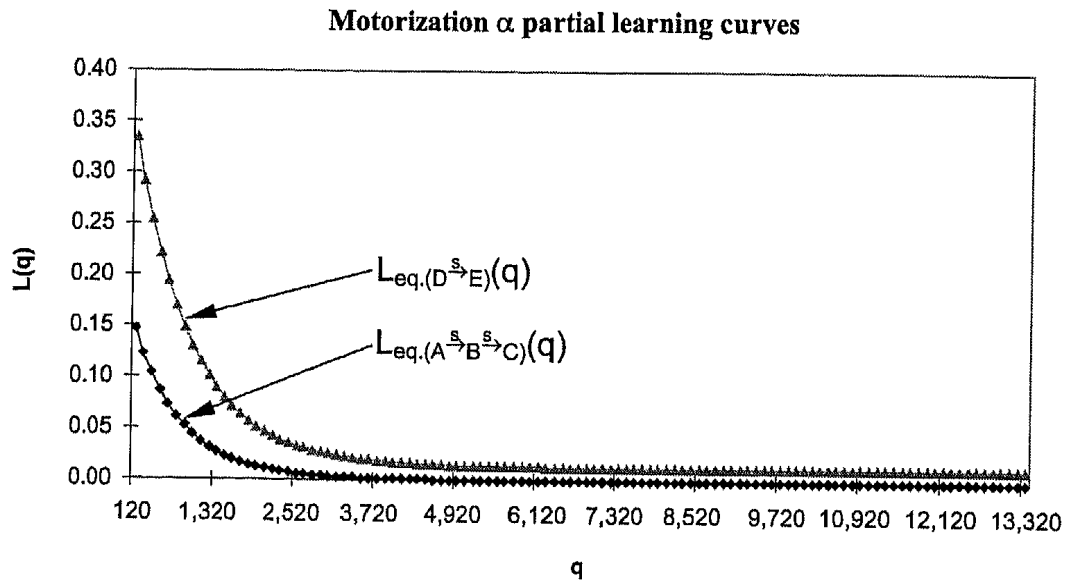
where  $L_{eq}(q)$  is the predicted learning curve value at  $q$ th production cycle and  $L_{exp}(q)$  is the experimental observation at  $q$ th production cycle.

Under the hypothesis that the values of  $L_{eq}(q)$  and  $L_{exp}(q)$  assume, locally, a normal distribution for each level  $L(q_i)$ , the 95 per cent confidence interval of  $\Delta(q)$  at  $q$ th production cycle can be obtained as follows:

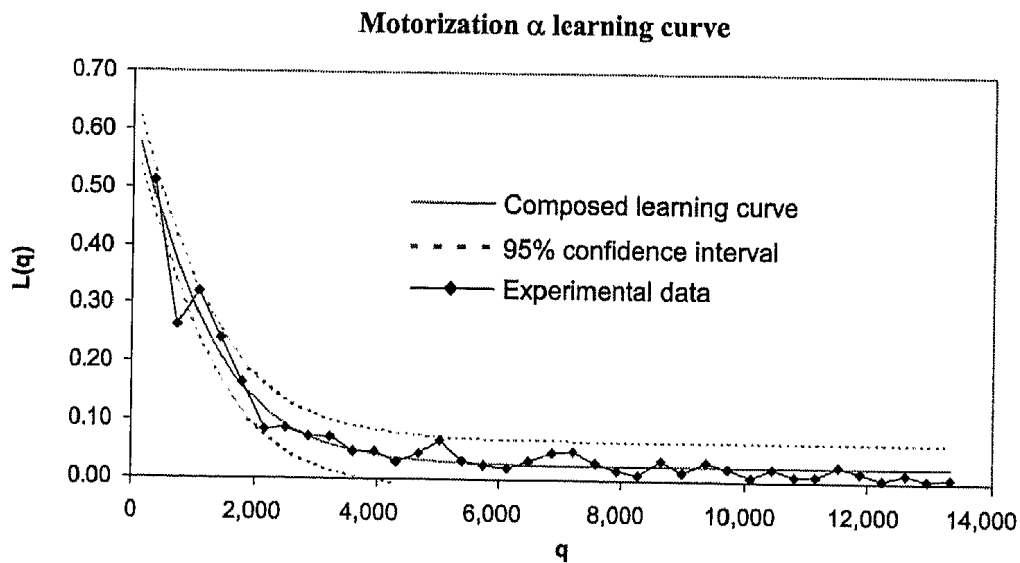
$$\pm 2\sigma_{\Delta}(q) = \pm 2\sqrt{\sigma_{L_{eq}}^2(q) + \sigma_{L_{exp}}^2(q)} \quad (10)$$

where  $\sigma_{\Delta}^2(q)$  is the variance of  $\Delta(q)$  at  $q$ th production cycle;  $\sigma_{L_{eq}}^2(q)$  is the variance of  $L_{eq}(q)$  at

**Figure 8** Comparison between composed learning curve of macro-phase series A, B and C (triangles), and composed learning curve of macro-phase series D and E (rhombuses)



**Figure 9** Experimental data (rhombuses) and composed learning curve for the whole motorization  $\alpha$  production system (continuous line)



**Note:** The corresponding 95% confidence interval on a single observation is also indicated [dotted lines]

the  $q$ th production cycle (for single values of  $L_{eq}(q)$ ) and  $\sigma_{L_{exp}}^2(q)$  is the variance of  $L_{exp}(q)$  at the  $q$ th production cycle (as a first approximation, this can be assumed equal to  $\sigma_{L_{eq}}^2(q)$ ).

According to the hypothesis test, the experimental and predicted values at each production cycle cannot be considered different if the 95 per cent confidence interval (equation (10)) includes the zero value (i.e. the null hypothesis  $H_0: L_{eq}(q) - L_{exp}(q) = 0, \forall q$ ).

Figure 11 shows  $\Delta(q)$  and its corresponding 95 per cent confidence interval. Beginning from a certain cycle, the confidence interval includes the zero value. Therefore, the experimental and

predicted values cannot be considered locally different (with a 95 per cent confidence level).

In the early phases of learning, the difference between the experimental and predicted values is rather high (> 25 per cent of defectiveness). We could suppose that the motorization  $\beta$ , which shows a lower initial average defectiveness, has gained an indirect advantage from adjustments carried out on the motorization  $\alpha$ . This fact is due to a knowledge exchange between the two motorization working teams (Franceschini and Galetto, 2003).

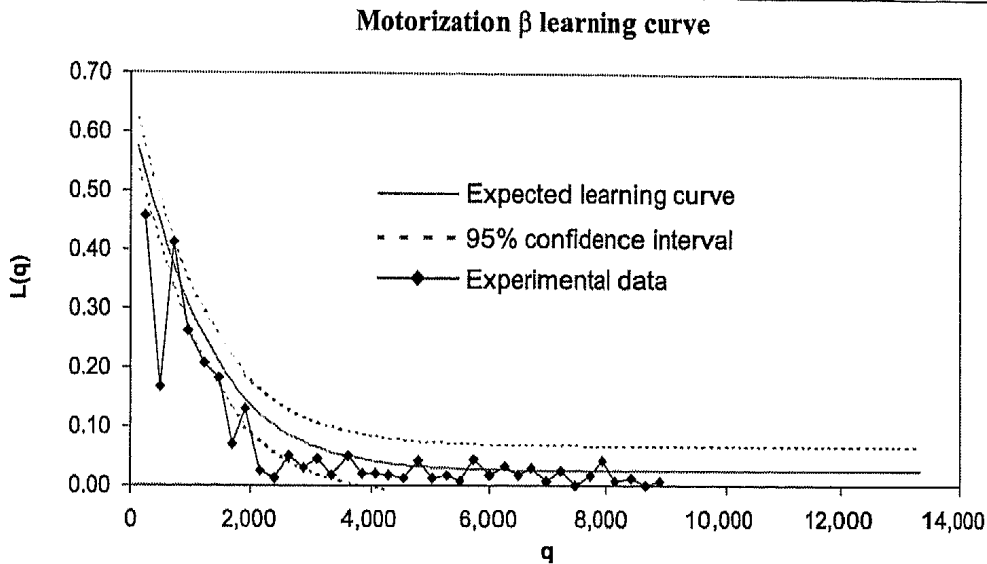
On the other hand, the test has shown that from the asymptotic point of view, the predicted and

**Table IV** Comparison between experimental and predicted numbers of rejected units ( $\Delta D(q)$ )

Macro-phase	Motorization $\beta$							
	5 days		15 days		25 days		35 days	
	Experimental	Predicted	Experimental	Predicted	Experimental	Predicted	Experimental	Predicted
A	0	1 ± 1	0	0 ± 1	0	0 ± 1	0	0 ± 1
B	0	4 ± 2	0	0 ± 1	0	0 ± 1	0	0 ± 1
C	0	2 ± 2	2	0 ± 2	0	0 ± 2	0	0 ± 2
D	28	8 ± 3	0	1 ± 2	4	1 ± 2	0	1 ± 2
E	22	16 ± 5	12	3 ± 5	0	2 ± 5	0	2 ± 5
F	0	36 ± 9	0	7 ± 9	0	3 ± 9	3	3 ± 9
Whole plant	50	61 ± 10	12	12 ± 10	4	6 ± 11	3	6 ± 11

**Note:** The corresponding 95 per cent confidence interval, after 5, 15, 25 and 35 working days is obtained for each macro-phase and for the whole plant of the motorization  $\beta$  on the basis of motorization  $\alpha$  analysis

**Figure 10** Experimental data (rhombuses) and expected learning curve for the whole production system of the motorization  $\beta$  (continuous line)



**Note:** The corresponding 95% confidence interval on a single observation is also indicated [dotted lines]. The expected learning curve for the whole production system of the motorization  $\beta$  was obtained by applying the composition laws and the estimated parameters for each single macro-phase of the motorization  $\alpha$ .

experimental values show a very similar behavior. This highlights the composition method ability to provide a planning tool to forecast the learning of new complex manufacturing systems. This information is very helpful during the early design phases. For example, if we consider two different design solutions to satisfy a given production, the method helps to evaluate which solution has to be preferred from the asymptotic defectiveness (learning) point of view.

Furthermore, the proposed method is better than the trivial practitioner "approach". We have shown that the new learning curve cannot be obtained by a mere summation of the learning curves of each single block. The suggested approach can be used as a planning tool to make an *a priori* comparison of different plant configurations without building them.

## 6. Conclusions

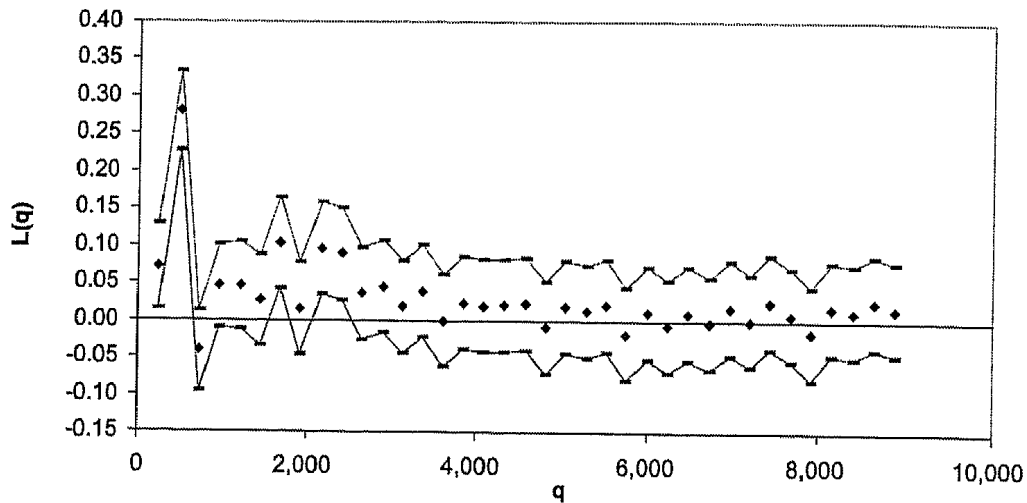
The paper presents a method for an experimental investigation of learning composition laws in the automotive exhaust-systems field. Two similar lines for exhaust-systems production (motorizations  $\alpha$  and  $\beta$ ) were analyzed. The comparison between the "theoretical" learning curve (obtained by an empirical parameters estimation of the motorization  $\alpha$ ) and the experimental results collected for the motorization  $\beta$ , has shown a good agreement for the prediction of asymptotical process defectiveness.

The main steps of the investigation procedure are as follows:

- defectiveness data collection during the early production phases of two similar production systems;

**Figure 11** Difference between the predicted learning curve values and the corresponding experimental observations, at each production cycle, for the whole manufacturing system of the motorization  $\beta$  (rhombuses)

### Motorization $\beta$ learning curves analysis



**Note:** The corresponding 95% confidence interval, at each production cycle, is also highlighted [segments]

- identification of elementary blocks;
- analysis of the empirical results and evaluation of the process parameters;
- application of the composition laws to the elementary blocks network; and
- comparison between expected theoretical values and experimental results.

The main characteristic of the composition law method is related to its ability to provide a forecast of non-conforming units of a complex manufacturing plant over time. This information is very helpful during the early design phases, allowing a rationalization of the industrial process. The analysis can be conducted both on the design of a new and on already existing plants.

Future developments will involve the means to individuate possible learning bottlenecks, as well as the mechanism that generates process learning mutual influence. Further analysis will be dedicated to the relationship between learning and plant design methodologies, focusing particular attention to the factors which may accelerate or slow down process learning.

## References

- Bailey, C.D. and McIntyre, E.V. (1997), "The relation between fit and prediction for alternative forms of learning curves and relearning curves", *IIE Transactions*, Vol. 29, pp. 487-95.
- Bevis, F.W., Finniear, C. and Towill, D.R. (1970), "Prediction of operator performance during learning of repetitive tasks", *International Journal of Production Research*, Vol. 8, pp. 293-305.
- Box, G.E.P., Hunter, W.G. and Hunter, J.S. (1978), *Statistics for Experimenters: An Introduction to Design, Data Analysis, and Model Building*, Wiley, New York, NY.
- Cherrington, J.E., Lippert, S. and Towill, D.R. (1987), "The effect of prior experience on learning curve parameters", *International Journal of Production Research*, Vol. 25 No. 3, pp. 399-411.
- Crossman, E.R.F.W. (1959), "A theory of the acquisition of speed skill", *Ergonomics*, Vol. 2, pp. 153-66.
- Franceschini, F. (2002), "Learning curves and p-charts for a preliminary estimation of asymptotic performances of a manufacturing process", *Total Quality Management*, Vol. 13 No. 1, pp. 5-12.
- Franceschini, F. and Galetto, M. (2002), "Asymptotic defectiveness of manufacturing plants: an estimate based on process learning curves", *International Journal of Production Research*, Vol. 40 No. 3, pp. 537-45.
- Franceschini, F. and Galetto, M. (2003), "Composition laws for learning curves of industrial manufacturing processes", *International Journal of Production Research*, Vol. 41 No. 7, pp. 1431-47.
- Laprè, M.A., Mukherjee, A.S. and Wassenhove, L.N.V. (2000), "Behind the learning curve: linking learning activities to waste reduction", *Management Science*, Vol. 46 No. 5, pp. 597-611.
- Levy, F.K. (1965), "Adaptation in the production process", *Management Science*, Vol. 11 No. 6, pp. 136-54.
- Montgomery, D.C. (2000), *Introduction to Statistical Process Control*, Wiley, New York, NY.
- Muth, J.F. (1986), "Search theory and the manufacturing progress function", *Management Science*, Vol. 32 No. 8, pp. 948-62.
- Naim, M.M. (1993), "Learning curve models for predicting performance of industrial systems", PhD thesis, Cardiff University.
- Roberts, P.C. (1983), "A theory of the learning process", *Journal of the Operational Research Society*, Vol. 34 No. 1, pp. 71-9.
- Sahal, D. (1979), "A theory of progress functions", *AIEE Transactions*, Vol. 11, pp. 23-9.

- Schneiderman, A.M. (1988), "Setting quality goals", *Quality Progress*, pp. 51-7, April.
- Seber, G.A.F. and Wild, C.J. (1989), *Nonlinear Regression*, Wiley Series in Probability and Mathematical Statistics, Wiley, New York, NY.
- Thorndike, E.L. (1898), "Animal intelligence: an experimental study of the associative processes in animals", *The Psychological Review: Ser. Monograph Supplements*, No. 2, pp. 1-109.
- Thurstone, L.L. (1919), "The learning curve equation", *Psychological Monographs*, Vol. 26, p. 114.
- Venezia, I. (1985), "On the statistical origins of the learning curve", *European Journal of Operational Research*, Vol. 19, pp. 191-200.
- Wright, T.P. (1936), "Factors affecting the cost of airplanes", *Journal of the Aeronautical Sciences*, No. 3.
- Yelle, L.E. (1979), "The learning curve: historical review and comprehensive study", *Decision Sciences*, Vol. 10 No. 2, pp. 302-28.
- Zangwill, W.I. and Kantor, P.B. (1998), "Toward a theory of continuous improvement and the learning curve", *Management Science*, Vol. 44 No. 7, pp. 910-20.