

Modeling of HEMT Devices Through Neural Networks: Headway for Future Remedies

*Original*

Modeling of HEMT Devices Through Neural Networks: Headway for Future Remedies / Kouhalvandi, Lida; Donati Guerrieri, Simona. - ELETTRONICO. - (2023), pp. 261-267. (Intervento presentato al convegno 10th International Conference on Electrical and Electronics Engineering (ICEEE) tenutosi a Istanbul, Turkiye nel 08-10 May 2023) [10.1109/ICEEE59925.2023.00054].

*Availability:*

This version is available at: 11583/2983721 since: 2023-12-29T12:10:34Z

*Publisher:*

IEEE

*Published*

DOI:10.1109/ICEEE59925.2023.00054

*Terms of use:*

This article is made available under terms and conditions as specified in the corresponding bibliographic description in the repository

*Publisher copyright*

IEEE postprint/Author's Accepted Manuscript

©2023 IEEE. Personal use of this material is permitted. Permission from IEEE must be obtained for all other uses, in any current or future media, including reprinting/republishing this material for advertising or promotional purposes, creating new collecting works, for resale or lists, or reuse of any copyrighted component of this work in other works.

(Article begins on next page)

# Modeling of HEMT Devices Through Neural Networks: Headway for Future Remedies

Lida Kouhalvandi<sup>1\*#</sup>, Simona Donati Guerrieri<sup>2\*</sup>

<sup>\*</sup> *Department of Electronics and Telecommunications, Politecnico di Torino, Turin, Italy*

<sup>#</sup> *Department of Electrical and Electronics Engineering, Dogus University, Istanbul, Turkey*

lida.kouhalvandi@ieee.org<sup>1</sup>, simona.donati@polito.it<sup>2</sup>,

**Abstract**—Small-signal and large-signal modeling of high electron mobility transistors (HEMTs) are developing day-by-day where accurate model extractions rely on characterizing the behaviour of transistors appropriately. Determining the suitable and optimal model structure with component values is not straightforward and requires significant effort especially at high frequencies. This modeling task is becoming more sensitive to numerical errors and convergence issues and needs careful consideration. Recently, neural networks (NNs) prove their beneficial applications in the radio frequencies design leading to accurate modeling. In this framework, this paper devotes to provide the comprehensive literature review around the various methods employed to modeling HEMT transistors through NNs. By referring to this review, radio designers can get a general view of HEMT modeling in one glance and can select the most suitable scheme for their applications.

**Index Terms**—modeling, high electron mobility transistor (HEMT), large-signal modeling, neural network (NN), small-signal modeling.

## I. INTRODUCTION

Wireless communication systems for fifth and sixth generations (5G/6G) are developing day-by-day, leading to improved data transfer [1]. The deployment of the radio frequency (RF) front-ends typically require microwave and mm-wave devices from enabling technologies. The GaN technology is preferred to silicon, due to its higher operation temperature, high breakdown electric field and electron saturation velocity [2]. Dedicated devices such as the high electron mobility transistors (HEMTs) based on wide bandgap semiconductors such as GaAs or GaN represent the state of the art for microwave applications [3], typically targeting 5G and beyond communication systems, vehicle networks [4], ultra wideband radar systems and space [5]. Recently, these devices have shown interesting applications also in heterogeneous engineering fields, including the medical and health areas (e.g. biosensing for COVID-19 [6]).

High power amplifiers (HPAs), used in the transmit chain of wireless communication systems, still represent the core of the applications for GaAs and GaN HEMTs [3], [7], [8]. HPAs design typically starts with the selection of the active devices (HEMTs) and develops by configuring the matching networks, sizing the passive structures by selected design parameters [9], [10]. Accurate HEMT modelling plays a crucial role in microwave design [11], [12], and poses significant challenges especially since GaN HEMTs are still undergoing significant process and structure optimization, to overcome the relative

immaturity of the GaN technology [13], [14]. Substrate engineering is also actively investigated, where Silicon, SiC or even diamond systems are used [15], [16], making transistor modelling even more involved.

Both small and large-signal GaN HEMT models, including noise and frequency conversion, are required for accurate circuit design. Besides TCAD physics-based analysis [17], equivalent-circuit based (compact) models are the first choice due to their ease of implementation into circuit simulators. At high frequencies, though, parasitic effects and low frequency dispersion due to trap dynamics and thermal effects make the circuit identification and parameter extraction more difficult [18], [19]. Behavioral models are also popular for nonlinear HEMT modelling, e.g. using polyharmonic distortion, X-parameters [20] or the Padé model [21], but their validity relies on the availability of large characterization data and the extrapolation capability is poor. The model extraction also requires significant numerical effort for optimization.

At the physical level, HEMT transistors are analyzed by Technology Computer Aided Design (TCAD) tools, e.g. Sentaurus Synopsys [22]. Despite physical models allow to speed up the device fabrication process, they are extremely numerical intensive, and not suited for circuit design. On the other hand, they provide the ideal platform to generate cheap and accurate surrogate data for the development of behavioral models [20] or artificial neural network based models [23], in substitution to expensive and complicated experimental campaigns [24].

In fact, artificial neural networks (ANNs) seem to be the ideal framework [25] to retain the high accuracy of device characterization or physical analysis with the numerical efficiency required in circuit simulation [26], [27]. Once trained with data generated from simulation or measurement platforms, ANNs virtual models can replace electromagnetic (EM)/physical models in the whole design, accelerating the circuit design.

A vast set of ANN-based HEMT modeling or, more in general, ANN-aided GaN circuit design, are present in the literature, making the overall scenario very crowded. It is becoming increasingly difficult to identify and classify the ANN approaches and modeling solutions. This paper provides a comprehensive review over the diverse surrogate techniques in the recently published literature, highlighting the pros, cons and challenges. This research aid designers in selecting the most suitable modeling approach for their applications.

This comprehensive review is organized as follows: Section

II provides a general descriptions of the adopted neural networks. Section III summarizes the various methods employed for HEMT modeling with ANNs. Finally, Sec. IV concludes this manuscript.

## II. ANN INVESTIGATION MODELLING IN A NUTSHELL

The intelligent-based networks have various subsets as presented in Fig. 1. Due to the requirements of various modeling, the suitable network type can be selected. As depicted in Fig. 1, machine learning (ML) includes any type of computer program and it is subset of artificial intelligent (AI) that can be fitted to the human interference. Deep learning (DL) is placing inside of ML where it uses the neural networks for matching to the learning process of the human brain. Additional specifications of each type are summarized in the appointed figure.

There are various kind of ANNs namely: multilayer perceptrons (MLPs), knowledge-based neural networks (KBNNs), and deep neural networks (DNNs) that are employed for various microwave applications such as: microwave filter designs [28]–[32], microwave antenna designs [33]–[35], RF amplifier designs [36]–[38], digital predistortion (DPD) [39], [40]. ANN with space mapping optimization method are employed e.g. in [19], [41] for learning electromagnetic (EM) and physics behaviour of RF designs. In this paper we focus on transistor modeling, which is the aim of Sec. III.

DNNs are the most widely used structures, which can be further subdivided into classes.

- Deep neural networks (DNN);
  - 1) Deep multilayer perceptrons (MLPs) [42]
  - 2) Convolutional neural network (CNN) [43]
  - 3) Deep belief network (DBN) [44]
  - 4) Knowledge-Based Neural Network [45]

A typical feature of microwave models, both at the device and circuit level, is that they must represent widely different data, ranging from DC, small-signal and multi-tone (usually represented in the frequency domain) or modulated signals (usually in a mixed time-frequency domain). This leads to exploiting a vast set of possible ANN structures. Feed-Forward Neural Networks are the simplest solutions usually adopted to model DC or frequency domain responses that are not adaptive in time. More complex ANN structures, such as the recurrent or Long Short-Term Memory ANNs are more apt to be trained with time-domain wave-forms or to be adaptive with the environment conditions (e.g. for energy-harvesting applications). The following scheme provides some examples of ANN structures proposed in the recent literature in this scenario.

- Feedforward Neural Networks (FFNNs) for passive and active circuit modeling, e.g. in DC or in the frequency domain [46], [47];
- Time-domain ANNs for time domain or mixed time-frequency domain modelling
  - 1) Dynamic neural networks [48]
  - 2) Recurrent neural networks (RNNs) [44]

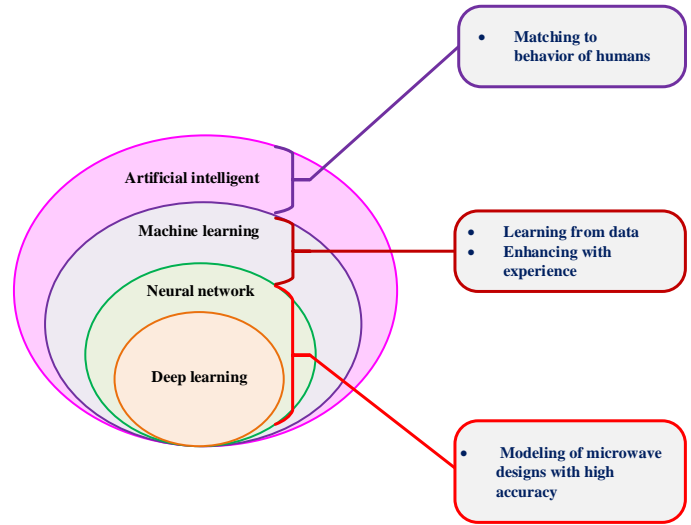

Fig. 1. AI, ML, and DL sub-sections.

- 3) Time-delay neural networks (TDNNs) [49]
- 4) Long Short-Term Memory (LSTM)-based DNN [36], [50]

Any engineer can develop the ANN by proper training, which can be done following the steps as below:

- 1) Determining the specifications of input layer;
  - each microwave design has its own characteristics. For example, they can be design parameters or input data of circuits [33], [36], [51], [52].
- 2) Providing the hyperparameters of ANN;
  - Hyperparameters include number of hidden layers and number of neurons in each layer [53].
- 3) Defining activation function with loss function [54];
- 4) Concluding the specifications of output layer;
  - The final layer includes characteristics that are targeted to be predicted [55].

## III. HEMT MODELING TECHNIQUES

This section devotes to summarize the methods and techniques used for modeling the active devices as HEMT transistors. In the recently published studies, various methods are reported for HEMT small-signal and large-signal modeling. Accurate analytical expressions can be used to develop corresponding compact models [11]. Analytic functions are not an effective modelling approach since they require significant effort for finding and fitting the model parameters depending on the device technology [56], [57]. To tackle this problem, artificial intelligent (AI) becomes a promising solution as it provides the relationship between the input and output data [25]. Table I at the end of this paper, presents the comprehensive view around these methods that are based on the the neural networks.

The main advantage of the ANN is to deal with large amount of data and to find the optimal solutions for the real-time engineering applications [58]. The construction of the ANN can be varied mostly based on the type of feedback,



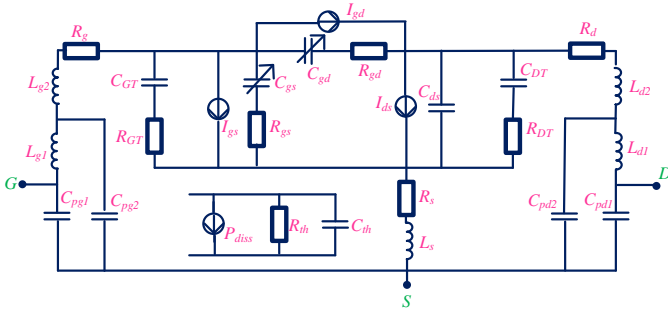

Fig. 7. Proposed equivalent circuit topology in [65] for AlGaIn/GaN HEMTs.

(potential) of gate and drain traps [18], paying attention to the gate and drain lag effects. In the generated model, the extrinsic parasitic parameters are achieved based on the artificial bee colony algorithm. For this case, the ANN is constructed to estimate the drain current values that are achieved from the I-V measurements.

In [64], an accurate consistent gate charge model is presented for modeling the GaN HEMT, again through a FFNN. The circuit parameters are extracted through multi-objective Gray-Wolf optimization (GWO) and the neural network is used for modeling the bias and temperature-dependent gate charges.

Further extending the above concepts, ANNs are employed in [65] for modeling HEMTs of AlGaIn/GaN technologies affected by significant buffer-related trapping effects. Such effects are especially difficult to model with analytic models. Fig. 7 presents the proposed topology of the equivalent circuit to include these effects. Here also, the use of ANN is preferred to identify the  $I_{ds}$  model as well as the trap and thermal models. First, a hybrid small-signal parameter-extraction method is used to extract the parasitic parameters. Then, the ANNs are introduced to describe trapping, breakdown, and self-heating effects. Finally, a new empirical equation is used for modeling the low-frequency dispersion, using the S-parameters to verify the buffer trap model.

Turning to small-signal models, the key elements to be extracted for accurate comparison with scattering parameters are the nonlinear capacitances or charges. In [66], ANN models for the gate and drain charges are performed with particle swarm optimization and it is verified using S-parameters.

In another study based on the genetic algorithm (GA) [67], temperature-dependent small-signal modeling methods are presented and verified with the S-parameters. Fig. 8 presents the structure of ANN used, with the input layers include four specifications of  $V_{GS}$ ,  $V_{DS}$ ,  $T$ , and  $f$ , and the output layer presents the real and imaginary parts of S-parameters.

Alternatively, for electrothermal small-signal modeling, [68] employs the scheme represented in Fig. 9, which includes various neural networks to represent S-parameter in terms of magnitude and phase. Temperature dependency is represented here by dedicated blocks cascaded to the ANNs.

Gray-Wolf optimization (GWO), inspired by grey wolves

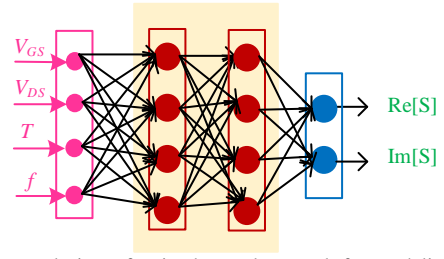

Fig. 8. Conceptual view of trained neural network for modeling the temperature dependent small-signal of GaN HEMT in [67].

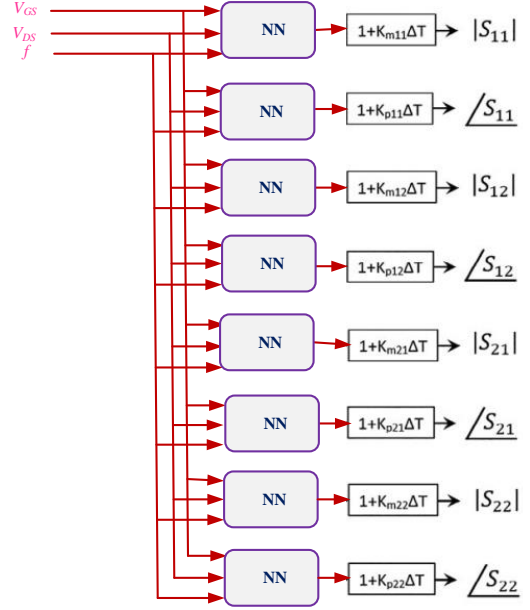

Fig. 9. NN presented in [68] for predicting the S-parameters in terms of magnitude, phase and temperature.

[69], is nowadays extensively used for modeling the GaN HEMT. Interestingly, the widespread of optimization methods needed for ANN training, has also fostered new and robust optimization methods to extract circuit elements of conventional equivalent circuits (Figs. 2-3). In Ref. [70], distributed parasitic capacitance are optimized with the GWO method in which the fitness function is maximized in terms of S-parameters, achieved through simulation and measurement. In [71]–[73], GWO method is employed for determining the values of components in HEMT model.

The above discussion has focused on equivalent circuits: these models, once made bias and temperature dependent, turn out to be also accurate and flexible large-signal HEMT modeling approaches. Despite this, more accurate, dedicated large-signal models (LSMs) are often required for HEMT models to be used in power amplifiers with large compression, self-heating and wideband modulated signals.

HEMT behavioral models are black-box flexible and general models that can fit wide sets of experimental data, including the time domain waveforms. As such, they are especially suited for large-signal modelling of devices operated with harmonic loads or fed by amplitude modulated wideband signals. Behavioral models are usually extremely difficult to

TABLE I  
SUMMARY OF VARIOUS METHODOLOGIES USED FOR MODELING THE GAN HEMT THROUGH NEURAL NETWORKS

Ref.	ANN type / optimization method	Kind of application
[60]	Feedback-based ANN	Modeling the IV characteristics
[63]	GA-based ANN and PSO-based SVR	Large modeling of HEMT and considering the dynamic trapping effects
[65]	LSM-based ANN	Large-signal modeling with a hybrid small-signal parameter-extraction
[70]–[72]	GWO method	Achieving the optimal values of HEMT's design parameters
[62]	GA-based ANN	IV characteristic and electrothermal modeling of HEMT
[67]	GA-based ANN	DC modeling of HEMT and presenting HEMT with S-parameter
[68]	Feedforward-based ANN	Presenting HEMT with S-parameter in terms of magnitude and phase
[61]	ANN-based bee colony algorithm	Large signal electrothermal model with IV characteristics
[64]	Feedforward ANN with GWO method	Modeling the bias and temperature-dependent gate charges

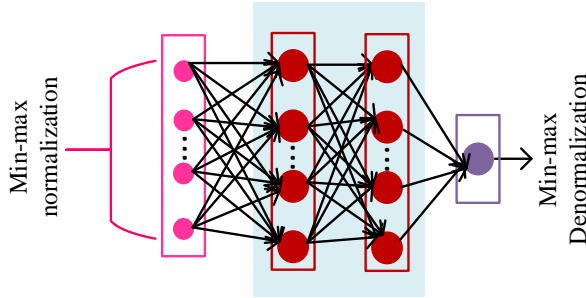

Fig. 10. The method presented in [81] for generating ANN where the input layer include incident waves and auxiliary variables to describe memory (time samples) and the output layer is the discrete time-sampled reflected wave. Input and output data min-max normalization is used.

extract, despite recently space mapping techniques have been proven successful [74]. A Wiener-type behavioral model based on ANN is reported in [48]. Behavioral models are also tightly related to the kind of measurement used for fitting. The DynaFET model [75] from Keysight exploits Nonlinear Vector Analyzer data to directly extract analytic expressions for  $I_d$  and  $Q_d$  as a function of the on temperature, two trap states, and instantaneous terminal voltages and implements them into the circuit simulator ADS by means of ANNs. X-parameters, also introduced by Keysight [76], are also a successful behavioral model for HEMTs, but they require large data files. In [77], X-parameters have been successfully coupled to ANNs to improve numerical efficiency. Large signal S-parameter based models are reported using real valued FFNN in [78]. Ref. [79] presents a review of large-signal ANN HEMT models based on load-pull systems. In particular two support vector regression (SVR) machines take incident waves (real and imaginary parts) as in input and return scattered waves as output. Time domain approaches including memory through waveform time samples are e.g. presented in [80]. The optimization is done based on the Z-parameter measurements. Space mapping is employed e.g. in [41] while in [19] for learning electromagnetic (EM) and physics behaviour of RF designs.

To be considered in the circuit-level, in [81] the multi-tone distortion based on time-domain is presented for modeling and predicting the transistors used in amplifier stages. For this case, the ANN is implemented and is used in a harmonic balance simulator (Keysight ADS). The general structure of the presented ANN is described in Fig. 10, as well.

#### IV. CONCLUSION

Designing RF circuits especially at high frequencies, is a challenging task and requires accurate modeling. The HEMT transistors are typically used in the design of amplifiers and have strong frequency dispersion. For this case, recently various modeling methods have been presented leading to consider the trapping effects of transistors. This paper devotes to provide a general view on various employed methodologies for providing small-signal and large-signal equivalent models of HEMT transistors. Due to the beneficial aspects of the ANN, this paper describes the physical knowledge and parameter extractions of HEMT transistors that are based on ANN network. Any designer by considering the various presented methods in modeling the HEMTs, can get benefit for their problems.

#### ACKNOWLEDGMENT

This work has been supported by the Italian Ministero dell'Istruzione, dell'Università e della Ricerca (MIUR) under the PRIN 2017 Project "Empowering GaN-on-SiC and GaN-on-Si technologies for the next challenging millimeter-wave applications (GANAPP)"

#### REFERENCES

- [1] H. Yin, J. Zhai, P. Chen, and C. Yu, "Directed graph navigated digital predistortion of mmWave power amplifiers for 6G hopping applications," *IEEE Microwave and Wireless Components Letters*, vol. 31, no. 11, pp. 1235–1238, 2021.
- [2] U. Mishra, P. Parikh, and Y.-F. Wu, "AlGaIn/GaN HEMTs—an overview of device operation and applications," *Proceedings of the IEEE*, vol. 90, no. 6, pp. 1022–1031, 2002.
- [3] V. Camarchia, R. Quaglia, A. Piacibello, D. P. Nguyen, H. Wang, and A.-V. Pham, "A review of technologies and design techniques of millimeter-wave power amplifiers," *IEEE Transactions on Microwave Theory and Techniques*, vol. 68, no. 7, pp. 2957–2983, 2020.
- [4] G. Lv, W. Chen, X. Liu, and Z. Feng, "A dual-band GaN MMIC power amplifier with hybrid operating modes for 5G application," *IEEE Microwave and Wireless Components Letters*, vol. 29, no. 3, pp. 228–230, 2019.
- [5] P. Waltereit, W. Bronner, R. Quay, M. Dammann, M. Cäsar, S. Müller, R. Reiner, P. Brückner, R. Kiefer, F. Raay, J. Kühn, M. Musser, C. Haupt, M. Mikulla, and O. Ambacher, "Gan hemts and mmics for space applications," *Semiconductor Science and Technology*, vol. 28, p. 074010, 06 2013.
- [6] L. Arivazhagan, D. Nirmal, A. Jarndal, H. F. Huq, S. Chander, S. Bhagyalakshmi, P. K. Reddy, J. Ajayan, and A. Varghese, "Applicability of double channel technique in AlGaIn/GaN HEMT for future biosensing applications," *Superlattices and Microstructures*, vol. 160, p. 107086, 2021.

- [7] F. Raab, P. Asbeck, S. Cripps, P. Kenington, Z. Popovic, N. Potheary, J. Sevic, and N. Sokal, "Power amplifiers and transmitters for RF and microwave," *IEEE Transactions on Microwave Theory and Techniques*, vol. 50, no. 3, pp. 814–826, 2002.
- [8] V. Camarchia, S. Donati Guerrieri, G. Ghione, M. Pirola, R. Quaglia, J. Moreno Rubio, B. Loran, F. Palomba, and G. Sivverini, "A K-band GaAs MMIC Doherty power amplifier for point-to-point microwave backhaul applications," in *International Workshop on Integrated Non-linear Microwave and Millimetre-Wave Circuits, INMMiC 2014*, 2014.
- [9] J. E. Rayas-Sánchez, S. Koziel, and J. W. Bandler, "Advanced RF and microwave design optimization: A journey and a vision of future trends," *IEEE Journal of Microwaves*, vol. 1, no. 1, pp. 481–493, 2021.
- [10] C. Ramella, A. Zanco, M. De Stefano, T. Bradde, M. Pirola, and S. Grivet-Talocia, "Efficient EM-based variability analysis of passive microwave structures through parameterized reduced-order behavioral models," in *2022 17th European Microwave Integrated Circuits Conference (EuMIC)*, 2022, pp. 5–8.
- [11] Z. Chen, Y. Xu, C. Wang, Z. Wen, Y. Wu, and R. Xu, "A large-signal statistical model and yield estimation of GaN HEMTs based on response surface methodology," *IEEE Microwave and Wireless Components Letters*, vol. 26, no. 9, pp. 690–692, 2016.
- [12] G. Avolio, A. Raffo, M. Marchetti, G. Bosi, V. Vadalà, and G. Vannini, "GaN FET load-pull data in circuit simulators: a comparative study," in *2019 14th European Microwave Integrated Circuits Conference (EuMIC)*, 2019, pp. 80–83.
- [13] Z. Jiang, L. Li, C. Wang, J. Zhao, and M. Hua, "Gate-bias induced threshold voltage ( $V_{th}$ ) instability in p-n junction/AlGaIn/GaN HEMT," *IEEE Transactions on Electron Devices*, vol. 69, no. 7, pp. 3654–3659, 2022.
- [14] H. Kocer, Y. Durna, B. Gunes, G. Tendurus, B. Butun, and E. Ozbay, "Fast unveiling of  $T_{max}$  in GaN HEMT devices via the electrical measurement-assisted two-heat source model," *IEEE Transactions on Electron Devices*, vol. 69, no. 5, pp. 2319–2324, 2022.
- [15] A. Jarndal, X. Du, and Y. Xu, "Modelling of GaN high electron mobility transistor on diamond substrate," *IET Microwaves, Antennas & Propagation*, vol. 15, no. 6, pp. 661–673, 2021.
- [16] A. Jarndal, "On modeling of substrate loading in GaN HEMT using Grey Wolf algorithm," *Journal of Computational Electronics*, vol. 19, no. 2, pp. 576–590, Jun 2020.
- [17] S. Donati Guerrieri, C. Ramella, F. Bonani, and G. Ghione, "Efficient sensitivity and variability analysis of nonlinear microwave stages through concurrent TCAD and EM modeling," *IEEE Journal on Multiscale and Multiphysics Computational Techniques*, vol. 4, p. 356 – 363, 2019.
- [18] G. P. Gibiino, A. Santarelli, and F. Filicori, "A GaN HEMT global large-signal model including charge trapping for multibias operation," *IEEE Transactions on Microwave Theory and Techniques*, vol. 66, no. 11, pp. 4684–4697, 2018.
- [19] Z. Zhao, L. Zhang, F. Feng, W. Zhang, and Q.-J. Zhang, "Space mapping technique using decomposed mappings for GaN HEMT modeling," *IEEE Transactions on Microwave Theory and Techniques*, vol. 68, no. 8, pp. 3318–3341, 2020.
- [20] S. Donati Guerrieri, F. Bonani, and G. Ghione, "Linking X parameters to physical simulations for design-oriented large-signal device variability modeling," in *2019 IEEE MTT-S International Microwave Symposium (IMS)*, 2019, pp. 204–207.
- [21] C. Wilson, A. Zhu, J. Cai, and J. B. King, "Pade-approximation based behavioral modeling for rf power amplifier design," *IEEE Access*, vol. 9, pp. 18 904–18 914, 2021.
- [22] "Synopsys tcad," <http://www.synopsys.com/silicon/tcad.html>, accessed: 2022-03-10.
- [23] Q.-J. Zhang, K. Gupta, and V. Devabhaktuni, "Artificial neural networks for RF and microwave design - from theory to practice," *IEEE Transactions on Microwave Theory and Techniques*, vol. 51, no. 4, pp. 1339–1350, 2003.
- [24] V. Rizzoli, A. Costanzo, D. Masotti, A. Lipparini, and F. Mastri, "Computer-aided optimization of nonlinear microwave circuits with the aid of electromagnetic simulation," *IEEE Transactions on Microwave Theory and Techniques*, vol. 52, no. 1, pp. 362–377, 2004.
- [25] S. Shalev-Shwartz and S. Ben-David, *Understanding Machine Learning: From Theory to Algorithms*. Cambridge University Press, 2014.
- [26] J. Zhang, J. Chen, Q. Guo, W. Liu, F. Feng, and Q.-J. Zhang, "Parameterized modeling incorporating MOR-based rational transfer functions with neural networks for microwave components," *IEEE Microwave and Wireless Components Letters*, vol. 32, no. 5, pp. 379–382, 2022.
- [27] W. Zhang, F. Feng, J. Jin, and Q.-J. Zhang, "Parallel multiphysics optimization for microwave devices exploiting neural network surrogate," *IEEE Microwave and Wireless Components Letters*, vol. 31, no. 4, pp. 341–344, 2021.
- [28] M. Sedaghat, R. Trinchero, and F. Canavero, "Compressed machine learning-based inverse model for the design of microwave filters," in *2021 IEEE MTT-S International Microwave Symposium (IMS)*, 2021, pp. 13–15.
- [29] X. Chen, Y. Tian, T. Zhang, and J. Gao, "Differential evolution based manifold gaussian process machine learning for microwave filter's parameter extraction," *IEEE Access*, vol. 8, pp. 146 450–146 462, 2020.
- [30] R. Kumar, S. S. L. Narayan, S. Kumar, S. Roy, B. K. Kaushik, R. Achar, and R. Sharma, "Knowledge-based neural networks for fast design space exploration of hybrid copper-graphene on-chip interconnect networks," *IEEE Transactions on Electromagnetic Compatibility*, vol. 64, no. 1, pp. 182–195, 2022.
- [31] F. Feng, W. Na, W. Liu, S. Yan, L. Zhu, J. Ma, and Q.-J. Zhang, "Multifeature-assisted neuro-transfer function surrogate-based EM optimization exploiting trust-region algorithms for microwave filter design," *IEEE Transactions on Microwave Theory and Techniques*, vol. 68, no. 2, pp. 531–542, 2020.
- [32] Y. Wu, G. Pan, D. Lu, and M. Yu, "Artificial neural network for dimensionality reduction and its application to microwave filters inverse modeling," *IEEE Transactions on Microwave Theory and Techniques*, pp. 1–1, 2022.
- [33] F. Mir, L. Kouhalvandi, L. Matekovits, and E. O. Gunes, "Automated optimization for broadband flat-gain antenna designs with artificial neural network," *IET Microwaves, Antennas & Propagation*, vol. 15, no. 12, pp. 1537–1544, 2021.
- [34] L.-Y. Xiao, W. Shao, F.-L. Jin, B.-Z. Wang, and Q. H. Liu, "Inverse artificial neural network for multiobjective antenna design," *IEEE Transactions on Antennas and Propagation*, vol. 69, no. 10, pp. 6651–6659, 2021.
- [35] L. Yuan, X.-S. Yang, C. Wang, and B.-Z. Wang, "Multibranch artificial neural network modeling for inverse estimation of antenna array directivity," *IEEE Transactions on Antennas and Propagation*, vol. 68, no. 6, pp. 4417–4427, 2020.
- [36] L. Kouhalvandi, O. Ceylan, and S. Ozoguz, "Automated deep neural learning-based optimization for high performance high power amplifier designs," *IEEE Transactions on Circuits and Systems I: Regular Papers*, vol. 67, no. 12, pp. 4420–4433, 2020.
- [37] Z. Liu, X. Hu, T. Liu, X. Li, W. Wang, and F. M. Ghannouchi, "Attention-based deep neural network behavioral model for wideband wireless power amplifiers," *IEEE Microwave and Wireless Components Letters*, vol. 30, no. 1, pp. 82–85, 2020.
- [38] X. Yu, X. Hu, Z. Liu, C. Wang, W. Wang, and F. M. Ghannouchi, "A method to select optimal deep neural network model for power amplifiers," *IEEE Microwave and Wireless Components Letters*, vol. 31, no. 2, pp. 145–148, 2021.
- [39] P. Jaraut, M. Helaoui, W. Chen, M. Rawat, N. Boulejfen, and F. M. Ghannouchi, "Review of the neural network based digital predistortion linearization of multi-band/MIMO transmitters," in *2021 IEEE MTT-S International Wireless Symposium (IWS)*, 2021, pp. 1–3.
- [40] X. Hu, Z. Liu, W. Wang, M. Helaoui, and F. M. Ghannouchi, "Low-feedback sampling rate digital predistortion using deep neural network for wideband wireless transmitters," *IEEE Transactions on Communications*, vol. 68, no. 4, pp. 2621–2633, 2020.
- [41] Q. Zhang, J. Bandler, S. Koziel, H. Kabir, and L. Zhang, "ANN and space mapping for microwave modelling and optimization," in *2010 IEEE MTT-S International Microwave Symposium*, 2010, pp. 980–983.
- [42] R. Hongyo, Y. Egashira, T. M. Hone, and K. Yamaguchi, "Deep neural network-based digital predistorter for Doherty power amplifiers," *IEEE Microwave and Wireless Components Letters*, vol. 29, no. 2, pp. 146–148, 2019.
- [43] Z. Wei and X. Chen, "Physics-inspired convolutional neural network for solving full-wave inverse scattering problems," *IEEE Transactions on Antennas and Propagation*, vol. 67, no. 9, pp. 6138–6148, 2019.
- [44] M. Noohi, A. Mirvakili, and S. A. Sadrossadat, "Modeling and implementation of nonlinear boost converter using local feedback deep recurrent neural network for voltage balancing in energy harvesting applications," *International Journal of Circuit Theory and Applications*, vol. 49, no. 12, pp. 4231–4247, 2021.

- [45] M. Iwamoto, J. Xu, W. Zhou, and D. E. Root, "Knowledge-based neural network (KBNN) modeling of HBT junction temperature and thermal resistance from electrical measurements," in *2017 IEEE MTT-S International Microwave Symposium (IMS)*, 2017, pp. 1069–1071.
- [46] W. Zhang, F. Feng, W. Liu, S. Yan, J. Zhang, J. Jin, and Q.-J. Zhang, "Advanced parallel space-mapping-based multiphysics optimization for high-power microwave filters," *IEEE Transactions on Microwave Theory and Techniques*, vol. 69, no. 5, pp. 2470–2484, 2021.
- [47] A. Viveros-Wacher and J. E. Rayas-Sánchez, "Analog fault identification in RF circuits using artificial neural networks and constrained parameter extraction," in *2018 IEEE MTT-S International Conference on Numerical Electromagnetic and Multiphysics Modeling and Optimization (NEMO)*, 2018, pp. 1–3.
- [48] W. Liu, W. Na, F. Feng, L. Zhu, and Q. Lin, "A Wiener-type dynamic neural network approach to the modeling of nonlinear microwave devices and its applications," in *2020 IEEE MTT-S International Conference on Numerical Electromagnetic and Multiphysics Modeling and Optimization (NEMO)*, 2020, pp. 1–3.
- [49] Z. Zhao, W. Na, V.-M.-R. Gongal-Reddy, and Q. Zhang, "Multi-band behavioral modeling of power amplifier using carrier frequency-dependent time delay neural network model," in *2017 IEEE MTT-S International Conference on Numerical Electromagnetic and Multiphysics Modeling and Optimization for RF, Microwave, and Terahertz Applications (NEMO)*, 2017, pp. 82–84.
- [50] M. Moradi A., S. A. Sadrossadat, and V. Derhami, "Long short-term memory neural networks for modeling nonlinear electronic components," *IEEE Transactions on Components, Packaging and Manufacturing Technology*, vol. 11, no. 5, pp. 840–847, 2021.
- [51] J. Zhang, F. Feng, W. Zhang, J. Jin, J. Ma, and Q.-J. Zhang, "A novel training approach for parametric modeling of microwave passive components using padé via lanczos and EM sensitivities," *IEEE Transactions on Microwave Theory and Techniques*, vol. 68, no. 6, pp. 2215–2233, 2020.
- [52] G. Cheng, M. Wang, W. Zhang, and X. Liu, "Advanced deep neural network technique for microwave parametric modeling," in *2021 IEEE MTT-S International Wireless Symposium (IWS)*, 2021, pp. 1–3.
- [53] L. Kouhalvandi and L. Matekovits, "Hyperparameter optimization of long short-term memory-based forecasting dnn for antenna modeling through stochastic methods," *IEEE Antennas and Wireless Propagation Letters*, vol. 21, no. 4, pp. 725–729, 2022.
- [54] L.-Y. Xiao, W. Shao, F.-L. Jin, B.-Z. Wang, W. T. Joines, and Q. H. Liu, "Semisupervised radial basis function neural network with an effective sampling strategy," *IEEE Transactions on Microwave Theory and Techniques*, vol. 68, no. 4, pp. 1260–1269, 2020.
- [55] Z. Lin, R. Guo, M. Li, A. Abubakar, T. Zhao, F. Yang, and S. Xu, "Low-frequency data prediction with iterative learning for highly nonlinear inverse scattering problems," *IEEE Transactions on Microwave Theory and Techniques*, vol. 69, no. 10, pp. 4366–4376, 2021.
- [56] A. Patnaik, N. K. Jaiswal, and P. Sharma, "Role of device parameters in optimizing 2DEG charge density in  $\beta$ -(Al<sub>x</sub>Ga<sub>1-x</sub>)<sub>2</sub>O<sub>3</sub>/Ga<sub>2</sub>O<sub>3</sub> HFET: An analytical approach," *IEEE Transactions on Electron Devices*, vol. 69, no. 7, pp. 3876–3883, 2022.
- [57] J. Waldron and T. P. Chow, "Physics-based analytical model for high-voltage bidirectional GaN transistors using lateral GaN power HEMT," in *2013 25th International Symposium on Power Semiconductor Devices IC's (ISPSD)*, 2013, pp. 213–216.
- [58] S. S. Indharapu and K. C. Durbhakula, "Analysis of training data sets in artificial neural networks applied to a radio frequency problem," in *2020 IEEE International Symposium on Antennas and Propagation and North American Radio Science Meeting*, 2020, pp. 1043–1044.
- [59] M. Quitadamo, D. Piumatti, M. Sonza Reorda, and F. Fiori, "Faults detection in the heatsinks mounted on power electronic transistors," *International Journal of Electrical and Electronic Engineering Telecommunications*, pp. 206–212, 01 2020.
- [60] A. Jarndal, "GaN HEMT electrothermal modeling using feedback neural networks technique," in *2019 International Conference on Electrical and Computing Technologies and Applications (ICECTA)*, 2019, pp. 1–4.
- [61] A.-D. Huang, Z. Zhong, W. Wu, and Y.-X. Guo, "An artificial neural network-based electrothermal model for GaN HEMTs with dynamic trapping effects consideration," *IEEE Transactions on Microwave Theory and Techniques*, vol. 64, no. 8, pp. 2519–2528, 2016.
- [62] A. Jarndal, "On neural networks based electrothermal modeling of GaN devices," *IEEE Access*, vol. 7, pp. 94 205–94 214, 2019.
- [63] A. Jarndal, S. Husain, M. Hashmi, and F. M. Ghannouchi, "Large-signal modeling of GaN HEMTs using hybrid GA-ANN, PSO-SVR, and GPR-Based Approaches," *IEEE Journal of the Electron Devices Society*, vol. 9, pp. 195–208, 2021.
- [64] W. Hu, H. Luo, X. Yan, and Y.-X. Guo, "An accurate neural network-based consistent gate charge model for GaN HEMTs by refining intrinsic capacitances," *IEEE Transactions on Microwave Theory and Techniques*, vol. 69, no. 7, pp. 3208–3218, 2021.
- [65] X. Du, M. Helaoui, A. Jarndal, T. Liu, B. Hu, X. Hu, and F. M. Ghannouchi, "ANN-based large-signal model of AlGaIn/GaN HEMTs with accurate buffer-related trapping effects characterization," *IEEE Transactions on Microwave Theory and Techniques*, vol. 68, no. 7, pp. 3090–3099, 2020.
- [66] A. H. Jarndal and S. Muhaureq, "A particle swarm neural networks electrothermal modeling approach applied to GaN HEMTs," *Journal of Computational Electronics*, vol. 18, no. 4, pp. 1272–1279, Dec 2019.
- [67] A. Jarndal, S. Husain, and M. Hashmi, "Genetic algorithm initialized artificial neural network based temperature dependent small-signal modeling technique for GaN high electron mobility transistors," *International Journal of RF and Microwave Computer-Aided Engineering*, vol. 31, no. 3, p. e22542, 2021.
- [68] A. Jarndal, "Neural network electrothermal modeling approach for microwave active devices," *International Journal of RF and Microwave Computer-Aided Engineering*, vol. 29, no. 9, p. e21764, 2019.
- [69] L. Kouhalvandi, I. Shayea, S. Ozoguz, and H. Mohamad, "Overview of evolutionary algorithms and neural networks for modern mobile communication," *Transactions on Emerging Telecommunications Technologies*, vol. 33, no. 9, p. e4579, 2022.
- [70] A. Jarndal, "Gray Wolf optimization-based modeling technique applied to GaN high mobility electron transistors," *IEEE Journal of the Electron Devices Society*, vol. 9, pp. 958–965, 2021.
- [71] A. H. Jarndal and M. B. al Sabbagh, "On modeling of substrate/buffer loading in GaN HEMT using Grey-Wolf optimization technique," in *2019 8th International Conference on Modeling Simulation and Applied Optimization (ICMSAO)*, 2019, pp. 1–5.
- [72] A. Abushawish and A. Jarndal, "Hybrid particle swarm optimization-Gray-Wolf optimization based small-signal modeling applied to GaN devices," *International Journal of RF and Microwave Computer-Aided Engineering*, vol. 32, no. 5, p. e23081, 2022.
- [73] A. H. Jarndal and A. S. Hussein, "Hybrid small-signal model parameter extraction of GaN HEMTs on Si and SiC substrates based on global optimization," *International Journal of RF and Microwave Computer-Aided Engineering*, vol. 29, no. 10, p. e21555, 2019.
- [74] J. Cui, F. Feng, Z. Zhao, W. Liu, W. Na, and Q.-J. Zhang, "Recent advances in space mapping technique modeling GaN HEMT," in *2021 14th UK-Europe-China Workshop on Millimetre-Waves and Terahertz Technologies (UCMMT)*, 2021, pp. 1–3.
- [75] J. Xu, J. Horn, M. Iwamoto, and D. E. Root, "Large-signal fet model with multiple time scale dynamics from nonlinear vector network analyzer data," in *2010 IEEE MTT-S International Microwave Symposium*, 2010, pp. 417–420.
- [76] J. Horn, D. E. Root, and G. Simpson, "Gan device modeling with x-parameters," in *2010 IEEE Compound Semiconductor Integrated Circuit Symposium (CSICS)*, 2010, pp. 1–4.
- [77] N. Lei, F. Jiang, and L. Sun, "X-parameter modelling of GaN HEMT based on neural network," *The Journal of Engineering*, vol. 2019, 12 2019.
- [78] J. Louro, C. Belchior, D. R. Barros, F. M. Barradas, L. C. Nunes, P. M. Cabral, and J. C. Pedro, "New transistor behavioral model formulation suitable for Doherty PA design," *IEEE Transactions on Microwave Theory and Techniques*, vol. 69, no. 4, pp. 2138–2147, 2021.
- [79] J. Cai, J. Su, and J. Liu, "Large signal behavioral modeling of power transistor from active load-pull systems," in *2019 IEEE International Symposium on Radio-Frequency Integration Technology (RFIT)*, 2019, pp. 1–3.
- [80] S. Zhang, X. Hu, Z. Liu, L. Sun, K. Han, W. Wang, and F. M. Ghannouchi, "Deep neural network behavioral modeling based on transfer learning for broadband wireless power amplifier," *IEEE Microwave and Wireless Components Letters*, vol. 31, no. 7, pp. 917–920, 2021.
- [81] A.-R. Amini and S. Boumaiza, "A time-domain multi-tone distortion model for effective design of high power amplifiers," *IEEE Access*, vol. 10, pp. 23 152–23 166, 2022.