

A refined one-dimensional model for the nonlinear analysis of smart structures

Original

A refined one-dimensional model for the nonlinear analysis of smart structures / Zappino, E.; Pagani, A.; Zhu, F.; Carrera, E.; Chen, W. Q.. - (2023), pp. 651-658. (10th ECCOMAS Thematic Conference on Smart Structures and Materials (smart2023) Patras (GR) 3-6 July, 2023).

Availability:

This version is available at: 11583/2992918 since: 2024-09-30T09:25:30Z

Publisher:

ECCOMAS

Published

DOI:

Terms of use:

This article is made available under terms and conditions as specified in the corresponding bibliographic description in the repository

Publisher copyright

(Article begins on next page)

A REFINED ONE-DIMENSIONAL MODEL FOR THE NON-LINEAR ANALYSIS OF SMART STRUCTURES

ENRICO ZAPPINO*★, ALFONSO PAGANI*, FANGZHOU ZHU †, ERASMO CARRERA* AND WEIQIU CHEN†

* Mul² Lab, Politecnico di Torino, Corso duca degli Abruzzi 24, Torino Italy

† Department of Engineering Mechanics, Zhejiang University, Hangzhou, P. R. China

★ Corresponding author: enrico.zappino@polito.it

Abstract. The present work extends the use of advanced one-dimensional models to non-linear analysis of piezoelectric structures. The theoretical formulation has been developed in the frameworks of the Carrera Unified Formulation, a numerical tool that allows arbitrary kinematic models to be easily derived. A fully coupled piezo-mechanical model has been considered. The model has been used to solve a well-know literature benchmark to verify the accuracy of the solution. The results have confirmed the capabilities of the model to predict the nonlinear solution.

Key words: Carrera Unified Formulation, Nonlinear analysis, piezoelectric, beam model

1 INTRODUCTION

The development of smart structures involves the use of thin structures with high flexibility in most applications. The analysis and design of these structures pose several problems from the point of view of the numeric models to be used. First, the structures are often laminated since the active material is commonly applied as a patch on a substrate with a structural function [1, 2]. The second difficulty is posed by the various physics involved in the problem that create complex deformation fields [3]. Ultimately, the high flexibility of the structures often results in nonlinear problems because of the large deformations involved [4]. Classical numerical models often cannot address the challenges just listed, so the use of solid models is the only option available to designers.

This paper proposes the use of advanced beam models for non-linear analysis of multilayer structures with piezoelectric inserts. The use of the Carrera Unified Formulation [5] has enabled the development of a coupled formulation for electro-mechanical problems, and the use of advanced kinematic models [6] has enabled quasi-3D solutions ensuring an excellent solution in both linear and nonlinear domains[7]. The present model has been assessed by comparing the results with those found in the literature. The results show that geometric non-linearities can

play a key role in the performance evaluation of smart structures, and it is necessary to consider them in order to achieve an effective design.

2 NON-LINEAR ONE-DIMENSIONAL MODELS FOR PIEZO-ELASTIC PROBLEMS

2.1 Carrera Unified Formulation

Within the framework of the Carrera Unified Formulation (CUF), the three-dimensional displacement field $\mathbf{u}(x, y, z)$, as well as the potential field, can be expressed as a general expansion of the primary unknowns. In the case of one-dimensional theories, one has:

$$\mathbf{u}(x, y, z) = F_\tau(x, z)\mathbf{u}_\tau(y), \quad \tau = 1, 2, \dots, M \quad (1)$$

where F_τ are the functions of the coordinates x and z on the cross-section, \mathbf{u}_τ is the vector of the generalized displacement which lays along the beam axis, M stands for the number of the terms used in the expansion, and the repeated subscript τ indicates summation. The choice of F_τ determines the class of the 1D CUF model that is required and subsequently to be adopted. In this work, Lagrange polynomials which is more suitable for electromechanical problems are chosen as F_τ to describe the cross-section unknowns, and the resulting beam theories are known as LE (Lagrange expansion) CUF models[5]. LE models utilize only pure displacements as primary unknowns. For detailed discussion about LE beam theories, please refer to the book written by Carrera and Petrolo [6].

In order to better discretize structure along beam (y)-axis, we exploit the classic Finite Element Method(FEM). The unknowns (i.e. generalized displacement vector) $\mathbf{u}_\tau(y)$ is approximated as follows:

$$\mathbf{u}_\tau(y) = N_i(y)\mathbf{u}_{\tau i} \quad i = 1, 2, \dots, p + 1 \quad (2)$$

where N_i stands for the i -th shape function, p is the order of the shape functions and i indicates summation. For brevity, the shape function will not be further discussed here. For readers with interest, there are many literature for reference, for example, Bathe[8]. In this work, elements with four nodes (B4) along the y axis are adopted herein.

It should be underlined that the choice of the cross-section polynomials sets for the LE kinematics (i.e. the selection of the type, the number and the distribution of cross-sectional polynomials) is completely independent of the choice of beam finite element to be used along the beam axis.

2.2 Nonlinear governing equations

For a conservative field, the stiffness matrices of the elements could be directly derived by means of principle of virtual work.

$$\delta L_{\text{int}} - \delta L_{\text{ext}} = 0 \quad (3)$$

where L_{int} is the strain energy, L_{ext} is the work of external loadings and δ represents the virtual variation. The secant stiffness matrix \mathbf{K}_S can be calculated from the virtual variation of the

strain energy δL_{int} , which reads:

$$\delta L_{int} = \langle \delta \bar{\boldsymbol{\epsilon}}^T \bar{\boldsymbol{\sigma}} + \delta \bar{\mathbf{E}}^T \bar{\mathbf{D}} \rangle \quad (4)$$

where $\langle (\cdot) \rangle = \int_V (\cdot) dV$. The transformed strain vector $\bar{\boldsymbol{\epsilon}}$ can be written in terms of the generalized nodal $\mathbf{u}_{\tau i}$ by means of eq. (1) and eq. (2):

$$\bar{\boldsymbol{\epsilon}} = (\mathbf{B}_l^{\tau i} + \mathbf{B}_{nl}^{\tau i}) \mathbf{u}_{\tau i} \quad (5)$$

where the $\mathbf{B}_l^{\tau i}$ and $\mathbf{B}_{nl}^{\tau i}$ are the linear and the nonlinear differential operators of the geometrical relation. The explicit form of these matrices can be found in [7]. As shown in strain energy eq. (4), It is easy to verify that the virtual variation of the strain vector (i.e. $\delta \boldsymbol{\epsilon}$) can be written in terms of nodal unknowns as follows:

$$\delta \boldsymbol{\epsilon} = (\mathbf{B}_l^{sj} + 2\mathbf{B}_{nl}^{sj}) \delta \mathbf{u}_{sj}. \quad (6)$$

Here, in writing eq. (6), the indexes s and j have been respectively employed instead of τ and i for the sake of convenience.

Substituting the constitutive equations, geometrical nonlinear equation(5) and its virtual variation form eq. (6) into the virtual variation of strain energy(4), the variation in internal work is given by:

$$\begin{aligned} \delta L_{int} = & \delta \mathbf{u}_{sj}^T \langle (\mathbf{B}_l^{sj})^T \bar{\mathbf{C}} \mathbf{B}_l^{\tau i} + (\mathbf{B}_l^{sj})^T \bar{\mathbf{C}} \mathbf{B}_{nl}^{\tau i} + (2\mathbf{B}_{nl}^{sj})^T \bar{\mathbf{C}} \mathbf{B}_l^{\tau i} + (2\mathbf{B}_{nl}^{sj})^T \bar{\mathbf{C}} \mathbf{B}_{nl}^{\tau i} \rangle \mathbf{u}_{\tau i} + \\ & \delta \mathbf{u}_{sj}^T \langle (\mathbf{B}_l^{sj})^T \bar{\mathbf{e}}^T \mathbf{B}_f^{\tau i} + (2\mathbf{B}_{nl}^{sj})^T \bar{\mathbf{e}}^T \mathbf{B}_f^{\tau i} \rangle \phi_{\tau i} + \\ & \delta \phi_{sj}^T \langle (\mathbf{B}_f^{sj})^T \bar{\mathbf{e}} \mathbf{B}_l^{\tau i} + (\mathbf{B}_f^{sj})^T \bar{\mathbf{e}} \mathbf{B}_{nl}^{\tau i} \rangle \mathbf{u}_{\tau i} + \delta \phi_{sj}^T \langle (\mathbf{B}_f^{sj})^T \bar{\boldsymbol{\chi}}^T \mathbf{B}_f^{\tau i} \rangle \phi_{\tau i} \end{aligned} \quad (7)$$

Equally, Eq. (7) can be written as:

$$\begin{aligned} \delta L_{int} = & \delta \mathbf{u}_{sj}^T \left(\mathbf{K}_{uu_{ll}}^{ij\tau s} + \mathbf{K}_{uu_{lnl}}^{ij\tau s} + \mathbf{K}_{uu_{nll}}^{ij\tau s} + \mathbf{K}_{uu_{nlnl}}^{ij\tau s} \right) \mathbf{u}_{\tau i} + \delta \mathbf{u}_{sj}^T \left(\mathbf{K}_{u\phi_l}^{ij\tau s} + \mathbf{K}_{u\phi_{nl}}^{ij\tau s} \right) \phi_{\tau i} \\ & + \delta \phi_{sj}^T \left(\mathbf{K}_{\phi u_l}^{ij\tau s} + \mathbf{K}_{\phi u_{nl}}^{ij\tau s} \right) \mathbf{u}_{\tau i} + \delta \phi_{sj}^T \left(\mathbf{K}_{\phi\phi_l}^{ij\tau s} \right) \phi_{\tau i} \end{aligned} \quad (8)$$

Specifically:

$$\begin{aligned} \mathbf{K}_{uu_{ll}}^{ij\tau s} = & \langle (\mathbf{B}_l^{sj})^T \bar{\mathbf{C}} \mathbf{B}_l^{\tau i} \rangle \quad \mathbf{K}_{uu_{lnl}}^{ij\tau s} = \langle (\mathbf{B}_l^{sj})^T \bar{\mathbf{C}} \mathbf{B}_{nl}^{\tau i} \rangle \quad \mathbf{K}_{uu_{nll}}^{ij\tau s} = \langle 2\mathbf{B}_{nl}^{sj} \rangle^T \bar{\mathbf{C}} \mathbf{B}_l^{\tau i} \rangle \\ \mathbf{K}_{uu_{nlnl}}^{ij\tau s} = & \langle 2\mathbf{B}_{nl}^{sj} \rangle^T \bar{\mathbf{C}} \mathbf{B}_{nl}^{\tau i} \rangle \\ \mathbf{K}_{u\phi_l}^{ij\tau s} = & \langle (\mathbf{B}_l^{sj})^T \bar{\mathbf{e}}^T \mathbf{B}_f^{\tau i} \rangle \quad \mathbf{K}_{u\phi_{nl}}^{ij\tau s} = \langle 2\mathbf{B}_{nl}^{sj} \rangle^T \bar{\mathbf{e}}^T \mathbf{B}_f^{\tau i} \rangle \quad \mathbf{K}_{\phi u_l}^{ij\tau s} = \langle (\mathbf{B}_f^{sj})^T \bar{\mathbf{e}} \mathbf{B}_l^{\tau i} \rangle \\ \mathbf{K}_{\phi u_{nl}}^{ij\tau s} = & \langle (\mathbf{B}_f^{sj})^T \bar{\mathbf{e}} \mathbf{B}_{nl}^{\tau i} \rangle \\ \mathbf{K}_{\phi\phi_l}^{ij\tau s} = & \langle (\mathbf{B}_f^{sj})^T \bar{\boldsymbol{\chi}}^T \mathbf{B}_f^{\tau i} \rangle \end{aligned} \quad (9)$$

From eq. (8), the secant stiffness matrix is divided into three parts: Mechanical part($\mathbf{K}_{S_{UU}}^{ij\tau s}$), Piezo-Electromechanical part($\mathbf{K}_{S_{U\Phi}}^{ij\tau s}$ and $\mathbf{K}_{S_{\Phi U}}^{ij\tau s}$) and Piezoelectrical part($\mathbf{K}_{S_{\Phi\Phi}}^{ij\tau s}$)

$$\begin{aligned}
 \mathbf{K}_{S_{UU}}^{ij\tau s} &= \mathbf{K}_{uu_{ll}}^{ij\tau s} + \mathbf{K}_{uu_{lnl}}^{ij\tau s} + \mathbf{K}_{uu_{nll}}^{ij\tau s} + \mathbf{K}_{uu_{nlnl}}^{ij\tau s} \\
 \mathbf{K}_{S_{U\Phi}}^{ij\tau s} &= \mathbf{K}_{u\phi_l}^{ij\tau s} + \mathbf{K}_{u\phi_{nl}}^{ij\tau s} \\
 \mathbf{K}_{S_{\Phi U}}^{ij\tau s} &= \mathbf{K}_{\phi u_l}^{ij\tau s} + \mathbf{K}_{\phi u_{nl}}^{ij\tau s} \\
 \mathbf{K}_{S_{\Phi\Phi}}^{ij\tau s} &= \mathbf{K}_{\phi\phi_l}^{ij\tau s}
 \end{aligned} \tag{10}$$

The explicit forms will be written by means of fundamental nuclei. These are 3×3 matrices that, given the cross-sectional functions ($F_\tau = F_s$, for $\tau = s$) and the shape functions ($N_i = N_j$, for $i = j$), can be expanded by using the indexes $\tau, s = 1, \dots, M$ and $i, j = 1, \dots, p + 1$ in order to obtain the elemental secant stiffness matrix of any arbitrarily refined beam model. Once the elemental secant stiffness matrix is obtained, it can be assembled in the classical way of FEM, see Carrera and Petrolo[5].

Last but not least, the Mechanical part($\mathbf{K}_{S_{UU}}^{ij\tau s}$) of the secant stiffness is asymmetric because of $\mathbf{K}_{uu_{nll}}^{ij\tau s} = 2(\mathbf{K}_{uu_{lnl}}^{ij\tau s})^\top$. The non-symmetry of the secant stiffness matrix may result in mathematical and practical drawbacks, which are discussed in Pagani[7].

2.3 Virtual variation of the work of external loadings

Beam structures are subjected to loading. As is known to us, Concentrated or Point load is a load acting on a small elemental area. In practice, a load can't be assumed to act on a single point just like a contact made by a sharp needle. In this work, a generic concentrated load vector \mathbf{P} can be written as:

$$\mathbf{P} = \left\{ \begin{array}{cccc} P_{u_x} & P_{u_y} & P_{u_z} & 0 \end{array} \right\} \tag{11}$$

Its virtual work is:

$$\delta L_{\text{ext}} = \mathbf{P} \delta \mathbf{u}^\top \tag{12}$$

Within the framework of CUF, the virtual variation of \mathbf{u} can be written as:

$$\delta L_{\text{ext}} = F_\tau \mathbf{P} \delta \mathbf{u}_\tau^\top \tag{13}$$

Introducing the shape functions and FE nodal parameter, eq. (13) can be rewritten as:

$$\delta L_{\text{ext}} = F_\tau N_i \mathbf{P} \delta \mathbf{u}_{\tau i}^\top \tag{14}$$

2.4 Solution procedure

In order to solve the geometrical nonlinear piezo electromechanical equations, the fixed point iteration is exploited in this work. The adopted fixed point iteration is a robust method and it

Algorithm: Fixed point iteration.	
1:	Choose a small number ε and $U_0 = 0$.
2:	For $i = 0, 1, 2, 3, \dots$ do
3:	Solve the linear system: $K_s(U_i) U_{i+1} = P$
4:	if $\ U_{i+1} - U_i\ < \varepsilon$
5:	Stop.
6:	end if
7:	end for

Table 1: Fixed point solution algorithm

is quite trivial to implement. However, its main drawback is that its rate of convergence is slow. Another limitation known to all is that it cannot deal with the snap through phenomenon which can be treated with the arc-length method[9, 10]. Therefore, applied with fixed-point iteration, the equilibrium condition can be written as

$$\mathbf{K}_s \mathbf{U} = \mathbf{P} \tag{15}$$

where \mathbf{K}_s , \mathbf{U} and \mathbf{P} are secant stiffness matrix, unknowns and concentrated load vector respectively. Generally, its algorithm is defined as follow:

3 NUMERICAL RESULTS

A bi-morph beams has been used to assess the present model. The geometry and the physical properties of the model are reported in Fig. 1 and in Tab. 2 respectively.

The dimensionless quantity $(PL^2/EI, \Delta/L)$ is utilized to describe response relation of a piezo bimorph cantilever beam. P (N) is the applied transverse load at the tip; L is the length of the bimorph beam; EI is the flexural rigidity and Δ is the tip deflection. The nonlinear and linear results corroborate well with those given by Fertis [11] and Mukherjee [4], respectively.

Figure 2 reports the results compared with those from literature. The numerical values of the equilibrium curve are reported in Tab 3. The results show a good agreement with the reference solution. When higher load are applied the response assume a highly non-linear behavior and make the linear solution inaccurate.

4 CONCLUSIONS

The present paper extends the use of one-dimensional model with advanced kinematic to the non-linear analysis of piezo-electric structures. At first the numerical formulation has been developed in the frameworks of the Carrera Unified Formulation. The governing equation have been written in terms of fundamental nuclei in order generalize the formulation and apply it to an arbitrary kinematic model. A bi-morph beam has been considered as benchmark to assess the present approach. The results have shown a good agreement with those presented in literature.

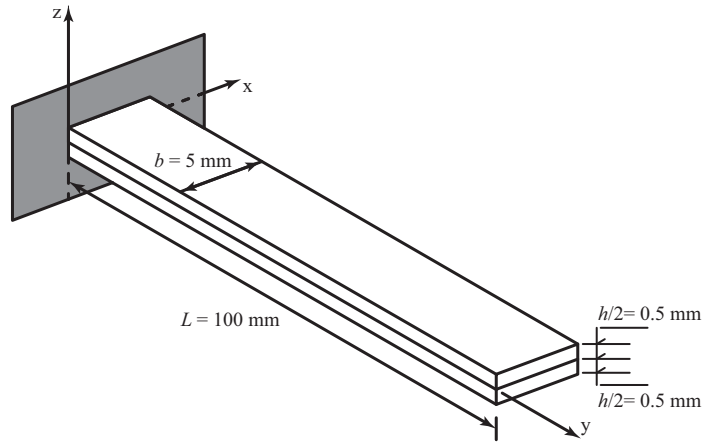

Figure 1: PVDF bimorph beam.

Table 2: Properties for bimorph cantilever beam.

PVDF		
Elastic modulus	2.00×10^9	Pa
Shear modulus	7.75×10^8	Pa
Mass density	1.80×10^3	Kg m^{-3}
Poisson's ratio	0.29	—
e_{31} Piezo	0.046	Cm^{-2}
e_{32} Piezo	0.046	Cm^{-2}
Elec. perm. χ_{11}	1.06×10^{-10}	Fm^{-1}
Elec. perm. χ_{22}	1.06×10^{-10}	Fm^{-1}
Elec. perm. χ_{33}	1.06×10^{-10}	Fm^{-1}
L length	0.1	m
h height	0.001	m
b width	0.005	m

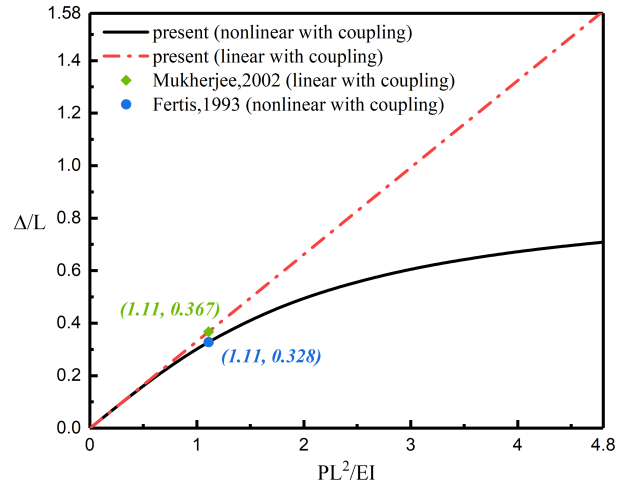

Figure 2: Validation figure for a piezoelectric bimorph cantilever beam.

Table 3: Equilibrium points $PL^2/EI, \Delta/L$ of the bimorph cantilever beam due to transverse load at its tip with different crosssection in-plane mesh orders.

$2 \times 2Q9 + 20B4$	
PL^2/EI	Δ/L
0.00	0.00000
0.60	0.19098
1.20	0.34773
1.80	0.46270
2.40	0.54475
3.00	0.60411
3.60	0.64820
4.20	0.68190
4.80	0.70834

The highly nonlinear response obtained for higher load has demonstrated the need of a non-linear solution since the linear approach overestimate the response.

REFERENCES

- [1] C. Y. Chee, L. Tong, and G. P. Steven, "A mixed model for composite beams with piezo-electric actuators and sensors," *Smart materials and Structures*, vol. 8, no. 3, p. 417, 1999.
- [2] H. Tzou and R. Ye, "Analysis of piezoelastic structures with laminated piezoelectric triangle shell elements," *AIAA journal*, vol. 34, no. 1, pp. 110–115, 1996.
- [3] E. Zappino and E. Carrera, "Advanced modeling of embedded piezo-electric transducers for the health-monitoring of layered structures," *International Journal of Smart and Nano Materials*, vol. 11, no. 4, pp. 325–342, Oct. 2020. [Online]. Available: <https://doi.org/10.1080/19475411.2020.1841038>
- [4] A. Mukherjee and A. S. Chaudhuri, "Piezolaminated beams with large deformations," *International Journal of Solids and Structures*, vol. 39, no. 17, pp. 4567–4582, 2002.
- [5] M. Petrolo, E. Carrera, M. Cinefra, and E. Zappino, *Finite element analysis of structures through unified formulation*. John Wiley & Sons, 2014.
- [6] E. Carrera and M. Petrolo, "Refined beam elements with only displacement variables and plate/shell capabilities," *Meccanica*, vol. 47, pp. 537–556, 2012.
- [7] A. Pagani and E. Carrera, "Unified formulation of geometrically nonlinear refined beam theories," *Mechanics of Advanced Materials and Structures*, vol. 25, no. 1, pp. 15–31, 2018.
- [8] K.-J. Bathe, *Finite element procedures*. Klaus-Jurgen Bathe, 2006.
- [9] M. A. Crisfield, "A fast incremental/iterative solution procedure that handles "snap-through"," in *Computational methods in nonlinear structural and solid mechanics*. Elsevier, 1981, pp. 55–62.
- [10] M. Crisfield, "An arc-length method including line searches and accelerations," *International journal for numerical methods in engineering*, vol. 19, no. 9, pp. 1269–1289, 1983.
- [11] D. G. Fertis, *Nonlinear mechanics*. CRC press, 1998.