

From Building Energy Models (BEM) to Urban Building Energy Models (UBEM): input data and modelling approaches

*Original*

From Building Energy Models (BEM) to Urban Building Energy Models (UBEM): input data and modelling approaches / Piro, M., Ballarini, I., Corrado, V.. - In: BUILDING SIMULATION CONFERENCE PROCEEDINGS. - ISSN 2522-2708. - ELETTRONICO. - (2024), pp. 2944-2951. (Building Simulation 2023: 18th Conference of IBPSA Shanghai (China) Sept. 4-6, 2023) [10.26868/25222708.2023.1662].

*Availability:*

This version is available at: 11583/2990426 since: 2024-07-06T14:06:50Z

*Publisher:*

IBPSA

*Published*

DOI:10.26868/25222708.2023.1662

*Terms of use:*

This article is made available under terms and conditions as specified in the corresponding bibliographic description in the repository

*Publisher copyright*

(Article begins on next page)

## From Building Energy Models (BEM) to Urban Building Energy Models (UBEM): input data and modelling approaches

Matteo Piro, Ilaria Ballarini, Vincenzo Corrado  
Politecnico di Torino, Turin, Italy

### Abstract

The past 15 years have seen a strong development of advanced new Urban Building Energy Model (UBEM) tools that have been generated with existing (e.g., EnergyPlus) or new calculation engines. Due to the high computational time and the huge level of uncertainty in UBEMs, the introduction of some model simplifications and assumptions becomes unavoidable. The present contribution addresses the differences between Building Energy Model (BEM) and UBEM for the categories that characterise the input data and the calculation models. General considerations, independent of specific energy performance simulation programs, are made. The analysis of the theoretical differences between the two calculation models provides useful support both to beginners and expert UBEM developers. A preliminary analysis of the mutual energy interactions between buildings in UBEMs is performed. Specifically, shortwave and longwave radiation exchanges between a building and the urban context are analysed and discussed, by comparing a single-building energy model and an urban building energy model. The analysis has been applied to a real neighbourhood, composed of eleven apartment blocks, sited in the northwest of Italy (Turin).

### Highlights

- Theoretical comparison between BEMs and UBEMs
- Preliminary investigation on mutual energy interactions within the urban context
- Guidelines for UBEM developers

### Introduction

Recently, a paradigm shift is taking place: the transition between the Building Energy Model (BEM) on the scale of a single building, to the Urban Building Energy Model (UBEM) on a city-level scale. The experience gained through the development of Building Energy Performance Simulation (BEPS) tools (Crawley et al., 2008) has allowed the introduction of assumptions and simplifications of the heat exchanges in the urban context.

Building Energy Modelling has defined as physics-based software simulation to assess building energy use (DOE, 2023). Energy models are divided into forward (classical) and data-driven (inverse) approaches (ASHRAE, 2013). BEM structure is characterised by (i) input variables, (ii) system structure and parameters or properties, and (iii) output (ASHRAE, 2013).

UBEMs follow the same classification. According to the scientific literature, large-scale energy analyses are usually classified as a function of two different methodological approaches: top-down and bottom-up models (Johari et al., 2020; Abbasabadi and Ashayeri, 2019; Kavgić et al., 2010; Swan and Ugursal, 2009). The top-down models, based on historical data series, are developed to examine the macro-relationships between the energy, technological, and economic sectors. On the other hand, in bottom-up models, the disaggregated data are used to estimate the end-use energy of a single or group of buildings. Bottom-up building stock energy models are commonly subdivided into three categories, namely engineering (or physical-based) models, statistical (or data-driven) models, and hybrid models. Despite varying interpretations, in agreement with Reinhart and Cerezo Davila (2016) and Johari et al. (2020), UBEM is a bottom-up approach physical-based model aimed at determining the energy need of a block, a district, or the whole city.

The complex and multi-domains energy flows in the city's environment can be explored through the generation of a large-scale energy model. However, the UBEM does not have a predefined spatiotemporal resolution, thus the level of geometric-informative details is inversely proportional to the scale analysis. This relationship is evident even in the transition between BEMs and UBEMs. In the literature, several contributions to the BEM and UBEM tools can be found. Ferrando et al. (2020) and Abbasabadi and Ashayeri (2019) presented an exhaustive picture of the UBEM tools used to determine the energy *status* of the building stock. Crawley et al. (2008), instead, compared a broad selection of energy simulation programs to assess the single-building energy performance.

The quantitative comparison between BEM and UBEM is quite challenging, and it is not universally valid if different BEPS are analysed and compared. To this purpose, two groups of differences between BEM and UBEM have been identified. The first one consists of the UBEM simplifications in the modelling of the building as such. For instance, transparent building envelope components in large-scale energy analysis are usually modelled as a function of the window-to-wall ratio (*WWR*) and are positioned from the centre of gravity of the façade of the building. In BEM, instead, windows are univocally spatially defined. The second group of differences regards the ability of UBEM to simulate the

interactions between the building and the surrounding environment; for instance, other buildings are considered as dynamic entities in the UBEM case and as shading and/or reflective elements in BEM. The solar radiation reflected on the assessed object, evaluated in a BEM, may instead be oriented, through the glazing components, to affect the energy balance of neighbouring buildings.

The objective of this paper is to emphasise the modelling characteristics between BEM and UBEM. This work begins with a theoretical analysis of characterisation of BEM and UBEM, including geometric model, building envelope, zoning, internal heat gains, and technical building systems. Moreover, calculation modules between urban and single-building energy models are compared and discussed. Next, a case study application with BEM and UBEM is conducted using the same energy simulation tool for both cases. In this way, the peculiarities of the mathematical models, related to the differences between single-building and urban building energy models, have been neutralised. Furthermore, the case study preliminarily investigate and compare the shortwave (SW) and longwave (LW) exchange between apartment blocks in a BEM and an UBEM for a real city block located in northwest Italy.

### **BEM vs. UBEM features**

The main difference between BEM and UBEM is the scale to which they refer. Undoubtedly, the choice between the two approaches depends on the purpose of the energy performance assessment. Increasing the scale of the energy analysis drastically decreases the accuracy of the energy model, even in favour of computational cost. In the following paragraphs, a theoretical and general comparison of the main BEM and UBEM features are presented. Specifically, the modelling assumptions of (i) the building geometry, (ii) the building envelope components, (iii) the zoning, (iv) the internal heat gains, and (v) the technical building systems have been investigated. Moreover, the main distinctions between single and multiple building energy performance calculation modules for the three heat transfer mechanisms (i.e., conduction, convection, and radiation) have been explored.

#### **Geometrical model**

In BEM, complex geometries are modelled according to the constraints imposed by the software utilised. The evolution from CAD (Computer-Aided Drawing) to BIM (Building Information Modelling) has revolutionised the Architectural Engineering and Construction (AEC) industry. Currently, geometric, and informational modelling take place in programs other than energy simulation tools. In this vision, interoperability of information, i.e., the capability to exchange data between two different simulation environments (such as BIM and BEM), becomes extremely important (Pezeshki et al., 2019). In this regard, the introduction of the open IFC (Industry Foundation Classes) and gbXML format for data exchange plays a crucial role. The urban context representation, instead, is mainly a mass modelling, with low complexity in the 3D model representation, obtained

by extruding in height the areal footprint of the buildings involved in the analysis. In UBEM, the urban building geometry depends on the Level of Detail (LOD). To geometrically represent a multiscale model, Kolbe et al. (2021) have updated the XML-based CityGML data model (Gröger et al., 2008; Gröger et al., 2012), based on four different standardised LODs (LOD0-3): LOD0 – “highly generalized model”, LOD1 – “block model/extrusion objects”, LOD2 – “realistic, but still generalised model”, and LOD3 – “highly detailed model”. Usually, in UBEM the most used LODs are LOD1 and LOD2. The differentiation is that LOD1 is like a shoebox model, instead in LOD2 the representation of oblique surfaces is allowed. In this latter case, sunlight studies can be carried out with a better degree of accuracy (e.g., shortwave irradiance calculation on roof surfaces, PV, or solar collector modelling). However, in v.3 of the CityGML standard (Kolbe et al., 2021) internal building elements (internal horizontal and vertical partitions) are allowed for every LOD level. An open research challenge involves the establishment of data interoperability between BIM and UBEM tools.

#### **Building envelope**

In an UBEM, the specification of the building envelope components (vertical, upper, and lower horizontal closure) can be usually done according to the orientation of the façade or can be attributed to the whole building. In the first case, if the stratigraphy of the envelope component varies along its vertical or horizontal axis, the developer would be unable to make the possible modification. In the second case, it will be possible to attribute only one stratigraphy package for each building component (wall, floor, or roof). In both situations, this will inevitably lead to simplifications. In the BEM, on the other hand, the degrees of freedom for modelling opaque building envelope components are increased.

The insertion of the glazed components in an UBEM takes place from the centre of gravity position of the façade of the floor or building. The opening of the windows is a function of the *WWR* (i.e., transparent percentage of the total wall), identical for the whole building or variable for each façade. This implies that the user will not be able to manage either the spatial position of the windows inside the façade or the actual size relative to that point. For instance, this simplification may lead to uncertainties regarding solar irradiation entering the thermal zone or the calculation of shadows, due to obstructions, projected on the glazed portion. Moreover, in large-scale modelling, if glazed components with different optical and energy performances are found in the same façade, an average behaviour is suggested. However, in UBEM tools with EnergyPlus as a calculation engine (e.g., UMI, CityBES, URBANopt) the number of parameters, normally included, especially for the transparent building envelope components, increases. In a BEM, on the other hand, the insertion of opaque and transparent building envelope components is univocally defined from both a thermophysical and a spatial point of view.

In UBEMs, the characterisation of the shading device is simplified by introducing a solar irradiance set-point. In other cases, if only importing the solar energy transmittance of the window is allowed, a weighting factor based on the opening/closing hours of the shading system is suggested. The rules for the operation of solar shading devices have been proposed in the EN ISO 52016-1 technical standard (CEN, 2018). Instead, in single-building energy modelling, the spatial location and thermophysical properties of solar shading devices are uniquely defined.

Thermal bridges, generally neglected, may be considered by adding in the energy of large-scale tools the total heat losses, due to punctual or linear thermal bridges, previously calculated. On the contrary in a BEM, the calculation of the linear thermal transmittance can be done by considering a numerical finite element calculation or by using an atlas of thermal bridges, depending on the evaluated geometric or structural discontinuity.

### Zoning

In an urban building energy model, the subdivision of the internal space with vertical and/or horizontal partitions is limited. Often the characterisation of the internal vertical partitions, identifiable through a corrective factor, is aimed at the mere calculation of the thermal capacity of the design environment. For horizontal subdivision, the user has more control, by setting overall building height and floor-to-floor height, and/or by fixing the inter-storey height, thus dividing zones by floor. In other cases, the current building elements, especially the vertical ones, cannot be specified. The identification of the thermal zones, in some cases, is influenced by the non-explicit modelling of internal partitions between different areas. Generally, in UBEM, the thermal zone will coincide with the entire building. This will inexorably have repercussions on the definition of the unconditioned thermal zones, on the evaluation of the technical building system, and on the assessment of the internal heat gains, since the latter two will be attributed to the predefined conditioned floor area. An elegant algorithm that automatically subdivides each floor of the building into perimeter and core thermal zones is integrated into UMI (Dogan et al., 2014). In a BEM, on the other hand, the identification of the thermal zones will take place in agreement with the different conditions of use, the complexity of the building, the technical building system, or in agreement with the legislative boundaries (e.g., the energy performance assessment of a building unit in an apartment block).

### Internal heat gains

In BEM and UBEM, the internal heat gains generally consider occupants, electrical appliances, and lighting equipment. For each of these, depending on the calculation time step, the internal heat gains schedules and the intensity of each thermal load must be specified. In accordance with Happle et al. (2018), the behaviour of occupants in an energy model can be studied deterministically or stochastically, with evaluations based

on person or space. However, in an UBEM, due to the high degree of uncertainty, the most common choice is to evaluate occupants deterministically with a space-based study. Since, in an UBEM the thermal zone generally coincides with the whole building, the degree of uncertainty in the assessment of the internal heat gains increases with the coexistence of different building use categories in the same building. For example, in an apartment block with several different commercial activities on the ground floor, a prevailing use and average behaviour should be considered, since the specified input data will be valid for the whole building. The definition of the internal heat gains, referred to the thermal zone, will not be made in a precise way (considering, for example, the interaction of the *i*-th light bulb inside the internal environment), but the estimation will have to be made on a parametric basis (evaluating, for example, the thermal quota coming from the electrical appliances as a function of the square meters of conditioned floor area). In a BEM, instead, the choice is made by the developer, deterministically or stochastically with punctual or parametric definition, depending on the complexity of the model and the known data.

### Technical building systems

The specification of the technical building systems in a BEM takes place considering, analytically or ideally, all the technological sub-system's performance: generation, storage, distribution, control, and emission. The complete investigation of each component will be done by evaluating its interaction with the environment in which it is installed, iterating the calculation in such a way that heat losses are compensated according to the demands of the thermal zone. This level of accuracy in most cases is unthinkable for urban building energy modelling. Therefore, the focus of the calculation will be on the type (e.g., boiler, heat pump, district heating, PV panels, solar collectors) and main characteristics of the generator installed (e.g., thermal power, energy efficiency, energy carrier, inlet/outlet temperature, etc.). In UBEMs, the specification of the technical building systems is mainly addressed to the generator. In some UBEM tools, through the introduction of simplified factors, the heat losses of some technical building sub-systems may be considered. Moreover, in UBEM tools there is little flexibility in introducing national regulations regarding on/off periods for the technical building systems operation (e.g., space heating system).

### Calculation module

In BEM and large-scale analysis, three different calculation methods have been developed: (i) monthly quasi-steady-state, (ii) simple hourly dynamic, and (iii) detailed hourly dynamic simulation. However, in agreement with the legislative evolution on building energy performance assessment, even in UBEM tools the hourly resolution is the most widespread.

In BEPS tools, the heat conduction model is formulated through either (i) the finite difference methods, (ii) the lumped parameters approach, (iii) the conduction transfer function methods, or (iv) the response factor method (De

Luca, 2022). In UBEMs, the finite or lumped discretisation of the building envelope components in a resistive-capacitive system (R-C) is frequent. Between the various models, the number of resistances and thermal capacitance changes. Some models take inspiration from the five resistances-one capacitance (5R1C) system of the EN ISO 13790 technical standard (CEN, 2008). Other R-C models discretise the building envelope components in 2R1C (Kämpf, 2009). In UMI, URBANopt, and CityBES the conduction model of EnergyPlus has been adopted.

The heat transfer by convection is based on Newton's law both in BEM and in UBEM simulation programs. Mainly, the different models are focused on the convective heat transfer coefficient calculation. The external heat transfer phenomena are described by (i) buoyancy-driven heat convection, (ii) forced convection (i.e., wind-driven), or (iii) mixed heat convection (i.e., wind and buoyancy-driven) (De Luca, 2022). Both in BEM and UBEM tools, the convective heat transfer coefficient is dependent on the weather conditions, or it is assumed constant. In large-scale models, the coupling with Computational Fluid Dynamics (CFD) numerical modelling tool is more effective than single-building energy modelling.

Different algorithms assess irradiance distribution in the UBEM scene. Some of them consider buildings as isolated objects without interaction with their surroundings. Another procedure evaluates the projected shadows of the nearby buildings without reflection, or the complex scenario where the reflection and shadowing have been mutually considered. The absorbed and reflected part of the glazed components is usually neglected. In the detailed algorithms, the sky vault is divided into several patches, with specific radiative properties, processing the partial or total visibility of the sky fraction for each UBEM surface. In large-scale energy tools, the LW exchange depends on the sky vault temperature, foreground temperature, and surface temperature calculation of the urban context.

In BEMs, the sky models are strongly dependent on the software implemented. Usually, isotropic and anisotropic sky models, with a preference for the latter, are utilised. In BEPS simulation programs, the external longwave radiation heat transfer is exchanged with the following components: (i) the sky vault, (ii) the ground, and (iii) the outdoor objects. However, in the single-building energy model, the surface temperature of the external objects is set equal to the outdoor air temperature. Therefore, the LW exchange is based on the radiative heat transfer to the sky vault and the external environment at air temperature value. In other cases, the Mean Radiant Temperature (MRT) of the external environment is assessed.

### Application

The best way to conduct the quantitative evaluation to explore BEM and UBEM differences would be to compare two representative simulation software programs, one suited for single-building energy modelling and one for the execution of a city-scale analysis. However, to neutralise any difference related to

the mathematical model of the building as such and to primarily investigate BEM and UBEM deviations in the interaction with the surrounding environment, the same tool (i.e., CitySim Pro) was used. In this way, the focus of the analysis is to examine the mutual energy interactions between buildings.

Therefore, four scenarios with progressive model complexity have been generated to investigate the energy exchanges between buildings.

### CitySim Pro

CitySim Pro, the predecessor of SUNtool, is an urban building energy simulation program (Robinson et al., 2009; Robinson, 2011; Mutani et al., 2018) developed by Solar Energy and Building Physics Laboratory of EPFL (L'École Polytechnique Fédérale de Lausanne). CitySim Pro is a good compromise between different needs: the level of detail of the input data, the accuracy of the output, and the computational time. The calculation engine of the software is CitySim Solver (CitySim Solver, 2020) on which the KAEMCO company developed a graphical user interface (GUI). The thermal model, validated through the BESTEST procedure (Emmanuel and Kämpf, 2015), is a resistive-capacitive system (Kämpf, 2009). The R-C model is detailed represented in Figure 1, where for simplifications the resistive-capacitive branch of the roof has not been shown.

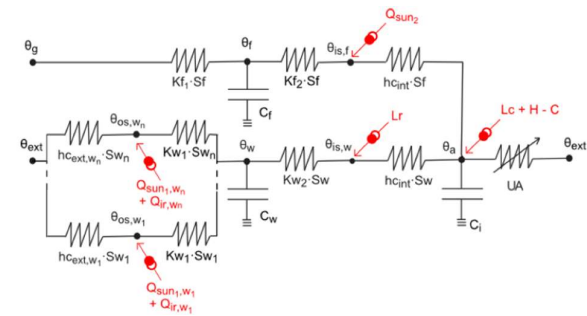

Figure 1: R-C model of CitySim Pro (Emmanuel and Kämpf, 2015).

The radiative model of CitySim Pro refers to the Simplified Radiosity Algorithm (SRA), introduced by Robinson and Stone (2005). The SRA is sensitive to the obstruction to the sun and to the sky vault both for the SW and LW exchange. According to the discretisation scheme of Tregenza and Sharples (1993), the sky vault is divided into 145 patches, each of which subtends a solid angle and has a specific radiosity value. Following the geometrical model importation and the calculation of view factors for each surface of the UBEM scene, the SRA estimates the SW and LW radiation. The longwave radiation exchanged by a surrounding surface is dependent on the temperature difference between the effective environment radiant temperature  $T^*$  (Robinson and Stone, 2005) and the surface temperature.

$$T^{*4} = \frac{1}{\pi} \left( T_{\text{sky}}^4 \sum_{i=1}^{145} (\Phi \sigma \cos \zeta)_i + \sum_{j=1}^{290} (\Phi \omega \cos \zeta T^4)_j \right) \quad (1)$$

In equation (1),  $T_{sky}$  and  $T$  respectively represent the sky and adjacent surface temperature,  $\Phi$  is the solid angle subtended by the sky patch,  $\sigma$  and  $\omega$  are the solar (i.e., the sky portion seen by the object surface) and obstruction view factor, and  $\zeta$  is the mean angle of incidence between the plane and the sky patch. In the effective environment radiant temperature calculation, the first term in brackets represents the contribution from the sky and the second from the surfaces at a different temperature that makes up the UBEM scene. As regards the SW contribution, the reflection is neglected for the glazed surfaces, and it is dependent on the SW reflectance coefficient for the opaque building envelope elements.

### Case study

The case study is a real block located in the northwest of Italy in the municipality of Turin (239 m a.s.l.). The city block is composed of eleven similar apartment blocks (A\_1, C\_1, B\_2, A\_3, C\_3, B\_4, A\_5, C\_5, B\_6, A\_7, and C\_7; see Figure 2) built after 1960. Each building has five inhabited storeys above ground. The buildings are entirely residential, with no commercial activities. In Table 1 the main geometrical characteristics are reported.

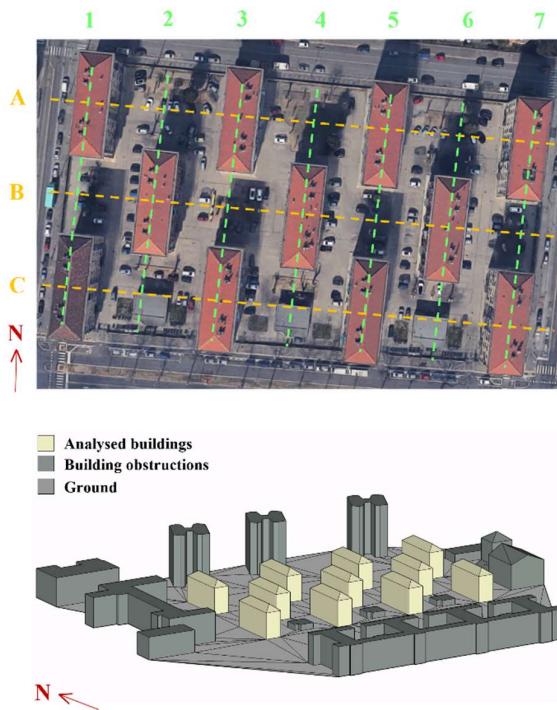

Figure 2: Satellite view of the city block (Google Maps) and 3D geometrical representation.

Table 1: Geometrical characteristics of the buildings.

Building footprint area	[m <sup>2</sup> ]	397
Overall thermally conditioned floor area	[m <sup>2</sup> ]	1166
Overall thermal envelope area (S)	[m <sup>2</sup> ]	2348
Gross volume (V)	[m <sup>3</sup> ]	7387
Compactness ratio (S/V)	[m <sup>-1</sup> ]	0.32

A homogeneous construction type of the apartment blocks is adopted: reinforced concrete skeleton with reinforced

concrete and hollow tiles mixed floor, completed vertically with hollow bricks wall. Figure 3 shows the WWR per each building and each façade orientation.



Figure 3: WWR per façade orientation.

The constructive features that compose the opaque and transparent building envelope components have been derived from the European project TABULA (Typology Approach for Building Stock Energy Assessment; Ballarini et al., 2014). These characteristics have been inferred from the climatic zone, the construction period, and the building size and shape. Moreover, the thermophysical properties of the materials have been extracted from the UNI/TR 11552 technical report (UNI, 2014), containing the abacus of the opaque building envelope components. The windows and the French windows of the dwellings, that compose the apartment blocks, have been assumed to be single-glazed with a wooden frame.

The International Weather for Energy Calculation (IWEC) file has been used to conduct the simulations. Moreover, the schedules and intensities of the internal heat gains (occupants, electrical appliances, and lighting equipment) have been derived from the draft Italian National Annex of EN 16798-1 (CTI, 2022), and the EN 16798-1 standard (CEN, 2022) for the missing data. The SW ground reflectance is equal to 0.10 (Thevenard and Haddad, 2006). Instead, the reflectance coefficient for the examined building depends on the solar absorption coefficient: assumed equal to 0.30 for light-coloured buildings (A\_1, C\_1, A\_3, C\_3, A\_5, C\_5, A\_7, and C\_7), and 0.60 for medium-coloured ones (B\_2, B\_4, and B\_6). The reflectance coefficient for the nearby obstructed buildings is 0.20.

### Energy models characteristics

This work provides a preliminary investigation regarding the quantitative energy mutual interactions between buildings. The objective of this analysis is to emphasise the complexity of energy exchange in an urbanised area. Usually, even in detailed BEMs, the analysis is oriented to the building energy performance assessment, placing the building in the foreground and its surroundings in the background. In single-building energy performance simulation, the surrounding buildings are typically modelled as obstructions, associating in some cases the solar reflection coefficient. However, the neighbouring buildings may play a crucial role, e.g., the solar reflection

within the urban environment or the longwave exchange with surfaces at a different temperature.

Two groups of simulation have been performed in CitySim Pro and the results have been focused on the apartment block sited in the middle of the analysed area (building B\_4; see Figure 2). For these reasons, four different scenarios (see Figure 4) with incremental complexity have been developed. The originated models are differentiated between single-building (BEM) and urban building energy models (UBEM).

BEM\_1

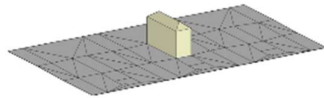

BEM\_2

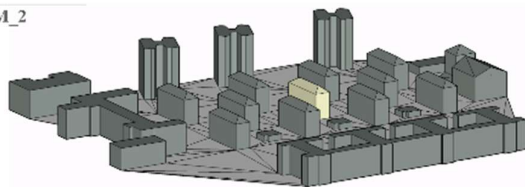

BEM\_3

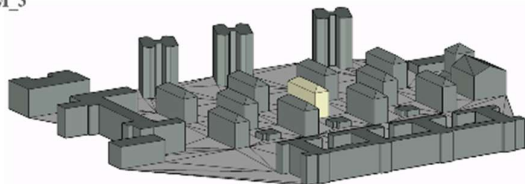

UBEM\_1

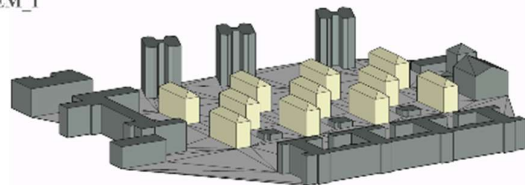

Figure 4: Calculation scenarios.

The first scenario (i.e., BEM\_1) is composed of the apartment block B\_4, without any obstructions and neighbouring buildings; in the second case (i.e., BEM\_2) nearby buildings have been modelled to shield the solar radiation with a null reflection coefficient; in the third case, instead, the buildings around have non-zero reflection coefficient (i.e., BEM\_3); and finally, the last scenario is a complete UBEM with the eleven apartment blocks detailed simulated (i.e., UBEM\_1), where buildings both reflect and absorb incident radiation in the simulation.

The first group of simulations investigates the amount of incident solar SW irradiance on one representative façade of building B\_4. This first group of energy performance simulations, composed of four different models (i.e., BEM\_1, BEM\_2, BEM\_3, and UBEM\_1), assesses the solar irradiation exchange between buildings.

The second group of simulations, on the other hand, examines the variation of the LW radiation on a characteristic façade of building B\_4 in scenarios BEM\_3 and UBEM\_1.

## Results and discussion

### Shortwave radiation

In Figure 5, for the four scenarios, the mean monthly incident solar radiation on the North façade of apartment block B\_4 is shown. The results of this group of simulations are strongly dependent on the nearby buildings shadows and on the reflectance coefficient of the opaque surface elements that compose the simulated scenario. The deviation between the first two bars (BEM\_1 vs. BEM\_2) represents the effect of the building shading. The variation is between  $-33\%$  and  $-38\%$ . The difference between BEM\_2 and BEM\_3, instead, considers the solar radiation reflected within the urban context due to neighbouring buildings and obstruction. The percentage increase due to the reflection of buildings on average is  $+41\%$ . Finally, per each month, the comparison of the last two bars (BEM\_3 vs. UBEM\_1) highlights the variation due to the modelling of the glazed components of the entire urban scene. According to the SRA of CitySim Pro, the reflected SW radiation on the transparent building envelope components is neglected. In the latter case, a constant monthly percentage decrease between  $-5\%$  and  $-7\%$  is shown. This deviation reflects the need for complete modelling of the surrounding context. In other words, the solar radiation reflected on the assessed apartment block, evaluated in a BEM (i.e., BEM\_3 scenario), may instead be oriented, through the glazing components, to the energy balance of neighbouring buildings (UBEM\_1 scenario), thus decreasing the entering solar heat gains into the thermal zone.

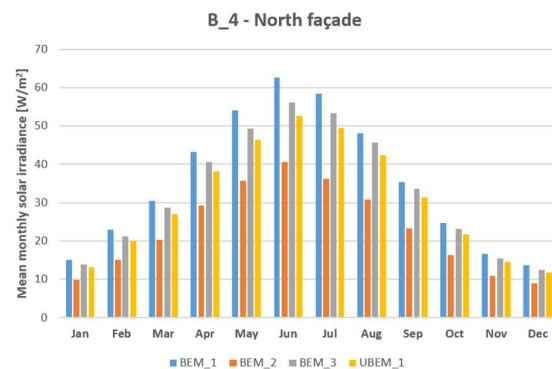

Figure 5: Mean monthly solar irradiance on the North façade of apartment block B\_4.

### Longwave radiation

As described previously, in BEM the obstruction's surface temperature is set equal to the external air temperature or is determined through the MRT. The LW exchange is influenced by the temperature of the sky vault, the ground, and the surfaces of the urban context. In Figure 6, the mean monthly longwave irradiance

exchanged on the West façade of the apartment block B\_4 is presented.

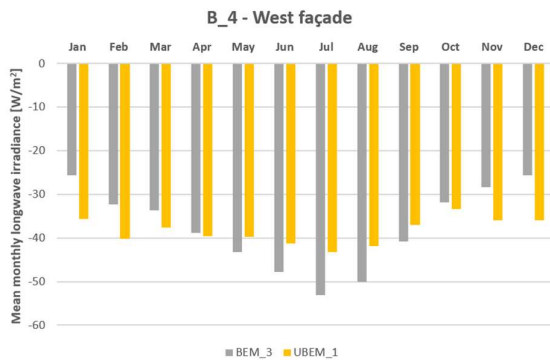

Figure 6: Mean monthly longwave irradiance exchanged on the West façade of apartment block B\_4.

The analysis has been conducted on the BEM\_3 and UBEM\_1 scenarios. The SRA integrated into CitySim Pro calculates the mean environment radiant temperature, influenced by the sky temperature, the surfaces temperature of the urban scene, the patch view factor (between the incident surface and the  $i$ -th sky vault patch), the angle of incidence, and the solid angle (Robinson and Stone, 2005). In the BEM\_3 scenario, the surface temperature of the obstructions is assumed to equal the default value of 288.15 K. On the other hand, in the UBEM\_1 scenario, the surface temperature for the neighbouring apartment blocks is calculated in detail through the building envelope components materials characterisation. Thus, the mean environmental radiant temperature in the BEM\_3 scenario is greater than UBEM\_1 during cold months: from January to April and from October to December. While, for the other months, from May to September, the trend reverses. During months with rigid temperatures (January and December), the percentage decrease of the net infrared balance radiation between UBEM\_1 and BEM\_3 is maximum and ranges from  $-28\%$  to  $-29\%$ . In July, instead, due to the lower environmental radiant temperature, the single-building energy model increased by  $+23\%$  compared to the large-scale model. In conclusion, the surface temperature of the urban scene plays a crucial role in the fair estimation of the longwave radiation exchanged and the surface temperature of the analysed building.

## Conclusion

The present work investigates the theoretical differences between UBEM and BEM tools. Simplifications and assumptions regarding building geometry, building envelope components, zoning, occupant behaviour and internal heat gains, and technical building systems were analysed both for urban and single-building scenarios. Moreover, the main calculation modules have been explored for the three heat transfer mechanisms. Considering a city block located in the municipality of Turin (Italy) as a case study, this paper preliminary investigates the SW and LW deviation between UBEM and the single-building energy performance simulation. The major differences in the two modelling approaches

can be ascribed to the energy mutual interaction that influences the district-scale building-oriented studies. The energy mutual influence between buildings can also alter the microclimate close to the urbanised area.

In conclusion, it is fundamental to provide proper guidelines both to beginners and to experts UBEM developers, supporting them in exploring modelling approaches and assumptions, to accurately simulate an urban building energy environment. Future works will provide a detailed quantitative comparison between single-building and urban building energy performance models.

## References

- Abbasabadi, N. and Ashayeri, M. (2019). Urban energy use modeling methods and tools: A review and an outlook. *Building and Environment* 161, 106270.
- American Society of Heating, Refrigerating and Air-Conditioning Engineers (ASHRAE). (2013). Chapter 19 - Energy Estimating and Modeling Methods. *2013 ASHRAE Handbook – Fundamentals*. Atlanta (USA).
- Ballarini, I., Corgnati, S.P. and Corrado, V. (2014). Use of reference buildings to assess the energy saving potentials of the residential building stock: The experience of TABULA project. *Energy Policy* 68, 273–284.
- CitySim Solver. (2020). CitySim Solver Official Code. <https://github.com/kaemco/CitySim-Solver>. Accessed 1 March 2023.
- Crawley, D. B., Hand, J. W., Kummert, M. and Griffith, B. T. (2008). Contrasting the capabilities of building energy performance simulation programs. *Building and Environment* 43(4), 661–673.
- De Luca, G. (2022). *Energy performance assessment of buildings: a novel approach for model validation*. Ph.D. thesis, Politecnico di Torino (Italy).
- Dogan, T., Reinhart, C. and Michalatos, P. (2014). Automated multi-zone building energy model generation for schematic design and urban massing studies. *Proceedings from eSim 2014: 8th Conference of IBPSA-Canada*. Ottawa (Canada), 7–10 May 2014.
- Emmanuel, W. and Kämpf, J. H. (2015). A verification of CitySim results using the BESTEST and monitored consumption values. *Proceedings from Building Simulation Application 2015: 2nd IBPSA-Italy conference*. Bozen (Italy), 4–6 February 2015.
- European Committee for Standardisation (CEN). (2008). *Energy performance of buildings. Calculation of energy use for space heating and cooling (EN ISO 13790)*.
- European Committee for Standardisation (CEN). (2018). *Energy performance of buildings -- Energy needs for heating and cooling, internal temperatures and sensible and latent heat loads -- Part 1: Calculation procedures (EN ISO 52016-1)*.

- European Committee for Standardisation (CEN). (2019). *Energy performance of buildings -- Ventilation for buildings -- Part 1: Indoor environmental input parameters for design and assessment of energy performance of buildings addressing indoor air quality, thermal environment, lighting and acoustics - Module M1-6 (EN 16798-1)*.
- Ferrando, M., Causone, F., Hong, T. and Chen, Y. (2020). Urban building energy modeling (UBEM) tools: A state-of-the-art review of bottom-up physics-based approaches. *Sustainable Cities and Society* 62, 102408.
- Gröger, G., Kolbe, T. H., Czerwinski, A. and Nagel, C. (2008). OpenGIS® City Geography Markup Language (CityGML) Encoding Standard; Version 1.0.0. OGC 08-007r1; Open Geospatial Consortium: Wayland, MA, USA.
- Gröger, G., Kolbe, T. H., Nagel, C. and Hafele, K. H. (2012). OGC City Geography Markup Language (CityGML) Encoding Standard; Version 2.0.0. OGC 12-019; Open Geospatial Consortium: Wayland, MA, USA.
- Happle, G., Fonseca, J. A. and Schlueter, A. (2018). A review on occupant behavior in urban building energy models. *Energy and Buildings* 174, 276–292.
- Italian Organisation for Standardisation (UNI). (2014). *Opaque envelope components of buildings -- Thermo-physical parameters (UNI/TR 11552)*. In Italian.
- Italian Thermo-technical Committee (CTI). (2022). *Draft of the Italian National Annex to EN 16798-1 (document no. 024100360)*. Restricted document.
- Johari, F., Peronato, G., P. Sadeghian, Zhao, X. and Widén, J. (2020). Urban building energy modeling: State of the art and future prospects. *Renewable and Sustainable Energy Reviews* 128, 109902.
- Kämpf, J. (2009). *On the Modelling and Optimisation of Urban Energy Fluxes*. Ph.D. thesis n. 4548, EPF de Lausanne (Switzerland).
- Kavgic, M., Mavrogianni, A., Mumovic, D., Summerfield, A., Stevanovic, Z. and Djurovic-Petrovic, M. (2010). A review of bottom-up building stock models for energy consumption in the residential sector. *Building and Environment* 45(7), 1683–1697.
- Kolbe, T. H., Kutzner, T., Smyth, C. S., Nagel, C., Roensdorf, C. and Heazel, C. (2021). OGC City Geography Markup Language (CityGML) Part 1: Conceptual Model Standard - Open Geospatial Consortium; OGC 20-010; Open Geospatial Consortium: Wayland, MA, USA.
- Mutani, G., Coccolo, S., Kaempf, J. and Bilardo, M. (edited by CreateSpace Independent Publishing Platform). (2018). *CitySim Guide: Urban Energy Modelling*.
- Pezeshki, Z., Soleimani, A. and Darabi, A. (2019). Application of BEM and using BIM database for BEM: A review. *Journal of Building Engineering* 23, 1–17.
- Reinhart, C. F. and Cerezo Davila, C. (2016). Urban building energy modeling – A review of a nascent field. *Building and Environment* 97, 196–202.
- Robinson, D. (edited by Darren Robinson). (2011). *Computer Modelling for Sustainable Urban Design: Physical Principles, Methods and Applications*. London (UK).
- Robinson, D. and Stone, A. (2005). A simplified radiosity algorithm for general urban radiation exchange. *Building Services Engineering Research and Technology* 26(4), 271–284.
- Robinson, D., Haldi, F., Kämpf, J., Leroux, P., Perez, D., Rasheed, A. and Wilke, U. (2009). CITYSIM: Comprehensive Micro-Simulation of Resources Flows for Sustainable Urban Planning. *Proceedings from Building Simulation 2009: 11<sup>th</sup> International IBPSA Conference*. Glasgow (Scotland), 27–30 July 2009.
- Swan, L. G. and Ugursal, V. I. (2009). Modeling of end-use energy consumption in the residential sector: A review of modeling techniques. *Renewable and Sustainable Energy Reviews* 13(8), 1819–1835.
- Thevenard, D. and Haddad, K. (2006). Ground reflectivity in the context of building energy simulation. *Energy and Buildings* 38(8), 972–980.
- Tregenza, P. and Sharples, S. (1993). *Daylighting algorithms*. ETSU Report S1350.
- U.S. Department of Energy (DOE). About Building Energy Modeling – Building. <https://www.energy.gov/eere/buildings/about-building-energy-modeling>. Accessed 1 March 2023.