

Design of a differential system focused on reusability and payload hosting capabilities for a rover based on rocker-bogie locomotion mechanism

Original

Design of a differential system focused on reusability and payload hosting capabilities for a rover based on rocker-bogie locomotion mechanism / Caraccio, L.; Rosso, C.; Festa, L. M.. - 2023-October:(2023). (74th International Astronautical Congress (IAC) Baku, Azerbaijan 2-6 Oct 2024).

Availability:

This version is available at: 11583/2992528 since: 2026-01-15T14:42:10Z

Publisher:

IAF Astro

Published

DOI:

Terms of use:

This article is made available under terms and conditions as specified in the corresponding bibliographic description in the repository

Publisher copyright

IAF/IAF postprint versione editoriale/Version of Record

Manuscript presented at the 74th International Astronautical Congress (IAC), Baku, Azerbaijan, 2023. Copyright by IAF

(Article begins on next page)

IAC-23,C2,1,x80253

Design of a differential system focused on reusability and payload hosting capabilities for a rover based on rocker-bogie locomotion mechanism

Mr. Lorenzo Caraccio

Politecnico di Torino, Italy, lorenzo.caraccio@polito.it

Prof. Carlo Rosso

Politecnico di Torino, Italy, carlo.rosso@polito.it

Mr. Leonardo Maria Festa

Politecnico di Torino, Italy, leonardomaria.festa@studenti.polito.it

Abstract

This study aims to design a complete differential system for a space rover that adopts a rocker-bogie mobility system following the related applicable documents in the mechanical fields in terms of the design and construction of a geared transmission system.

The design process is focused both on a transmission mechanism and on an external structure that connects the two halves of the mobility system. The parts are developed using a custom-made MATLAB code for the calculus implementation for a preliminary design of the gears and the shafts. The design is then verified through the software MitCalc. The external structure is studied through a finite element analysis on Hexagon MSC Nastran with Patran. After the production and assembly phases a performance test campaign has been conducted to verify the correct functioning of the transmission mechanism under operative movement velocity and mechanical tests on the external structure under the application of different loads, both in static and dynamic conditions, verified by inspection or using specific tools when needed, to confirm the correctness of finite element analysis studied in the design phase.

The idea behind the project is to develop a system that permits the rover to be a strongly modular developing platform, avoiding the more classical differential bar coupled to this kind of mobility system, which puts strong constraints on what could be the effective buildable area around the mechanical structure of the rover. Adopting this design, the usable volume around a less constrained central core can be maximized in order to host bigger external payloads in different positions of the rover. In these terms, when used as an astronaut assistance rover, thanks to the mechanical structure that guarantees this modularity, it presents many possibilities of reuse in a different configuration with different payloads.

This work is developed in the environment of the DIANA student team from Politecnico di Torino, which took part in different competitions such as the Rover Challenge Series, connecting different student teams from all over the world and students from different engineering areas with the main focus to design a working prototype of a space rover.

Keywords: Differential system, Rocker-bogie mechanism, Payloads hosting, Space structures, gears backlash, FEM Analysis.

1. Introduction

Since 1970 with the Soviet rover Lunokhod1 [1], the exploration of extraterrestrial bodies has played a central role in space exploration and the search for life on other planets in the solar system.

The future of exploration involves human bases on other planets [2], where human-robot interaction will play an important role during small crossings, scientific sample collection missions, and manipulation tasks [3]

As the rover becomes fundamental for astronaut assistance, becoming a modular development platform [4] is of primary importance for accomplishing several tasks, this setup could become a standard for future astronaut assistance rovers.

Already confirmed by several missions and studies conducted on the field, Rocker-bogie [5] mechanism seems to be the most efficient mechanism for the exploration of harsh and uneven terrain.

By definition, this kind of mechanism requires a differential system to ensure the necessary grip during the traverse, this differential system could consist of a differential bar or a gearbox [6].

The following study aims to find a solution for the gearbox design and related structure for a planetary rover for astronaut assistance, as a requirement the structure should be stiff enough to sustain a set of payloads, meanwhile, the gearbox should consent to the mobility system, to overcome obstacles of known height.

The designing process starts from the mechanical requirements: load condition, material selection, and geometry for gears and splined shaft that will constitute the gearbox, these components have been designed through specific ISO normative, then for the splined shafts a verification method was proposed directly from the normative, for the gears instead a software called Mitcalc was used as a verification method.

The gearbox gives geometrical constraints on the external structure in terms of height and depth, the length of the external structure is constrained by the maximum dimension of the payloads that would be hosted, a reasonable value has been chosen.

The structure is then verified through a finite element analysis conducted on Hexagon MSC Nastran with Patran.

After the design phase, the parts have been produced and assembled, the whole system has been subjected to field tests to evaluate the correctness of the analysis and the dynamical behavior.

Figure 1 shows the steps followed from the design to the construction of the system.

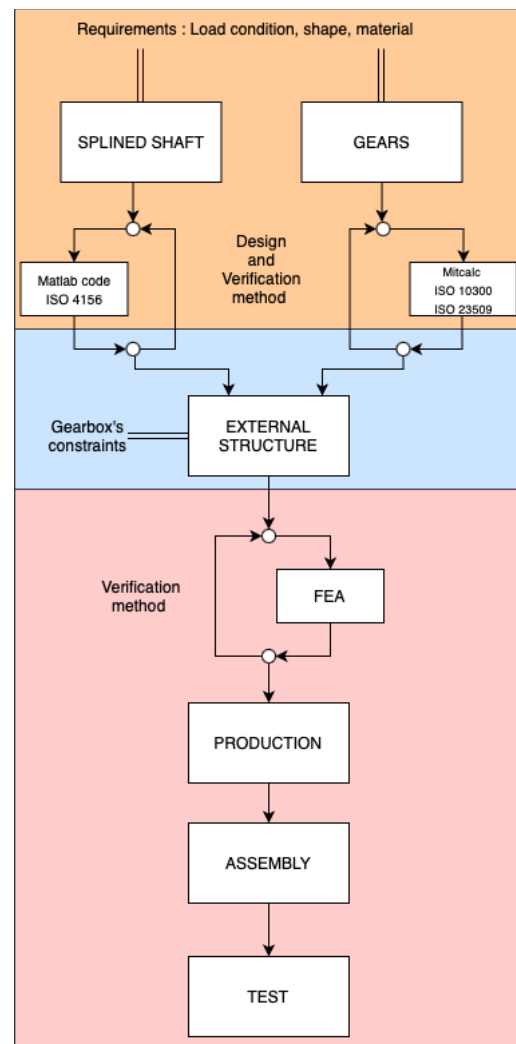

Fig. 1. Design steps

2. General requirements and material selection

Differential systems are composed of bevel gears, in general with a helical profile, Considering the low speed of the case studied a straight bevel gear has been chosen mainly to reduce production error that usually comes up in the production of Gleason or Hypoid gears [7].

A set of four gears has been selected as the best for load distribution.

As a requirement, a value of 60 Nm has been chosen as the torque transferred on each shaft of the differential system, and so the same torque is exchanged between shaft and gears.

On the external structure instead, a value of 500 N has been chosen as the applied load, which should be comprehensive of battery, avionics, and payloads of the planetary rover prototype.

The material selected for the first production of the model was Aluminum alloy 7075-T6 for the external structure, AISI 3115 (UNI 16NiCr4) steel for gears, and AISI 4142H (UNI 38CrMo4) for the splined shaft and the plates that connect the shaft to the rocker-bogie mechanism.

Considering the space application of the product, the Aluminum 7075-T6 can be substituted by more used 7075-T73 which presents better properties in corrosive environments. [8]

The components made of steel could remain the same because no thermal treatments were meant to be done during the development of the parts. Thermal treatment couldn't be so effective in space application, and the rigidity of the external layer of the components could increase the fracture growth.

3. Design, Production and Assembly

This section is characterized by the application of main ISO standards for the design of the components and the verification methods.

3.1 Splined Shafts

Considering a Torque of 60 Nm applied on each shaft the selected dimensions for the hollow shafts, are $D_{ext} = 15 \text{ mm}$ and $D_{int} = 10 \text{ mm}$ results verified through traditional calculus methodology.

The design of the splined parts starts with the choice of the tooth profile, the selected one is the CUNA profile, which permits a higher number of teeth and so the regulation of the system to balance the load applied on it, and allows during the production to chose a side fit in the mate and avoid backlash.

After the selection of the previous characteristic the relative standard are applied [9][10][11].

The procedure suggested by the standards is implemented in a Matlab code that allows the calculus iteration based on the number of teeth to find the optimum values for the teeth's geometric parameters and coefficients.

At the end of the design phase, the verification method is based on the relationship between different parameters:

$$0.6 > \frac{L}{d} = \frac{m * \Omega}{k} \leq 1.5$$

To derive this formulation the calculation is:

$$F = p_a A_c$$

$$A_c = \left(\frac{D-d}{2} - 2c\right)L \text{ area of the lateral contact surface}$$

The maximum transmissible force is:

$$F = p_a \left(\frac{D-d}{2} - 2c\right)L$$

To take in account the non-uniform distribution of the pressure the utilization coefficient should be introduced:

$$F = \psi p_a \left(\frac{D-d}{2} - 2c\right)L$$

The total force on the N spline generate a torque

$$M_t = \psi p_a \left(\frac{D-d}{2} - 2c\right)L \frac{D+d}{4} N$$

Considering:

$$M_t = \frac{\pi d^3}{16} \tau_a$$

$\psi = 0.75$ utilization coefficient

$$m = \frac{\pi}{2\psi} = 2.10 \text{ for fix mating with no load}$$

$$k = \frac{p_a}{\tau_a}$$

$$\Omega = \frac{d^2}{(D-d-4c)(D+d)N}$$

D: external diameter

d: internal diameter

c: teeth height

N: number of spline

L: contact axial length

p_a : unitary admissible pressure on the contact surfaces

τ_a : unitary admissible torsional stress

M_t : maximum torque that the load could support

In the end, the splined shaft result was correctly designed with a verification factor of $\frac{L}{d} = 0.6342$

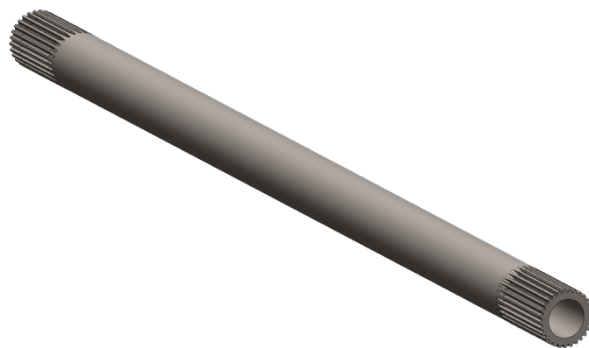

Fig. 2. Splined Shaft design

3.2 Straight Bevel Gears

The gear design process starts with the selection of different values of mean modulus and number of teeth that guarantee the gears are stiff enough and remain in a certain range of dimensions.

The followed process is proposed by ISO standards [12][13][14].

The selected values are $z = 25$ teeth and $m_{mn} = 2.5$. So the general dimension of the gear is $d_m = 62.5mm$. These parameters are then verified through the software MitCalc, which is based on the application of the related standard through an Excel spreadsheet. The parameters given as input to the software are:

Then, the resultant safety factor of gear is $SF = 2.5$.

As said in the general requirement section, the system is composed of four gears coupled, two on the side, one on the top, and one below, everyone with 90-degree angles between each other.

To prevent problems related to backlash in the gear mates, the lower gear was mounted tilted thanks to a

mechanism based on screw-nut, the mechanism permits the variation of the angles in a range of 10-20° with respect to the vertical axis (fig.4). [15]

The regulation of the mechanism avoids backlash according to the different loads applied to the structure, different loads require different angles.

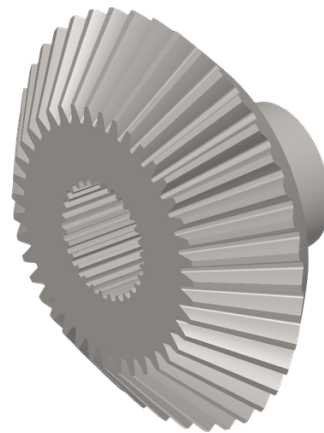

Fig. 3. Straight bevel gear design

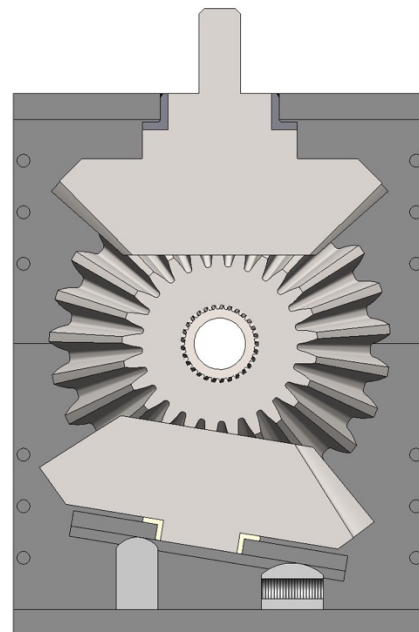

Fig. 4. System section

3.3 External Structure

For the structure design, a process similar to the gears has been followed, and different concepts are verified through a FEM analysis conducted on Hexagon MSC Nastran with Patran.

The final design was chosen considering stiffness, lightness, and simplicity for production.

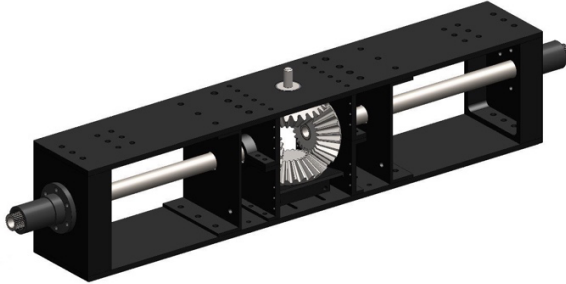

Fig. 5. Complete differential system design

4. Reusability

As said, the focus of the selection to use a gearbox instead of a more classical differential bar is the idea to let the rover be equippable with interchangeable modules where each module corresponds to different payloads, specific for the tasks that the rover alone, or coupled with a human companion, has to complete.

The solution to obtain the modularity could be based on linear guides attached to the main structure of the differential system.

A solution for payload disposition is proposed in the following image:

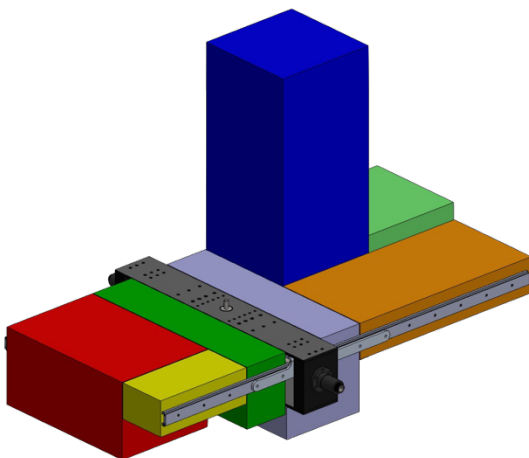

Fig. 6. Payloads allocation mock-up

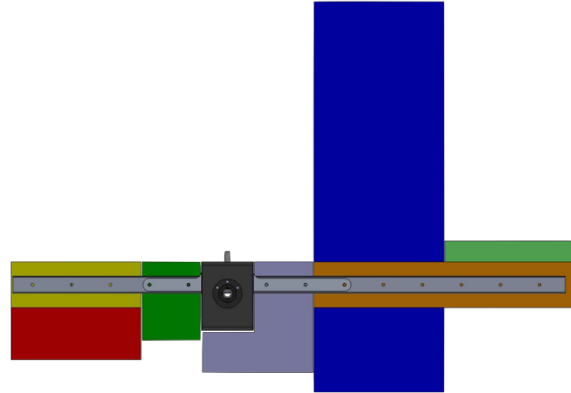

Fig. 7. Side view of Payloads allocation mock-up

5. Test and Results

After a production campaign, the prototype was assembled on the engineering model of a planetary rover developed by Team DIANA, a student team from Politecnico di Torino.

Some junction plates have been produced to make the system to be compatible with the rover.

The systems have been loaded with a robotic arm, a soil sampler, two modules of power and avionics, and a sampler container, supporting a load of 29,4 kg applied of the structure without showing any sign of failure both in statics and operative dynamic condition on the external structure.

The differential system was also tested during the overcoming of obstacles high 20-30 cm showing a correct meshing of the gear teeth. The splined shaft instead, thanks to the high number of teeth, permits the correct balance of the load applied to the structure by rotating the structure around its axis.

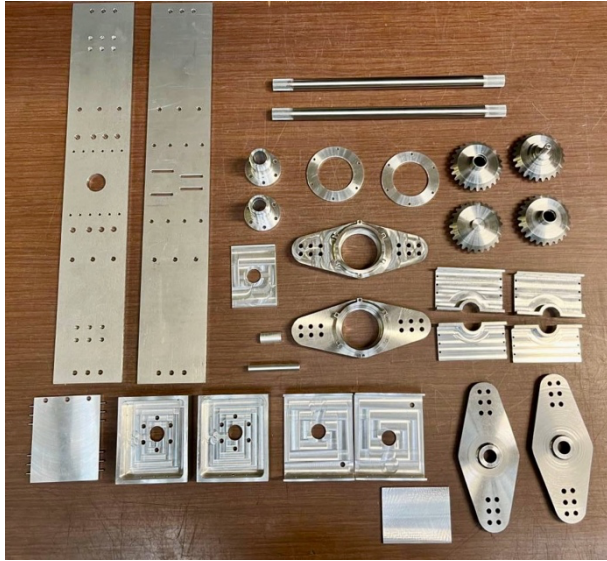

Fig. 8. Differential system production

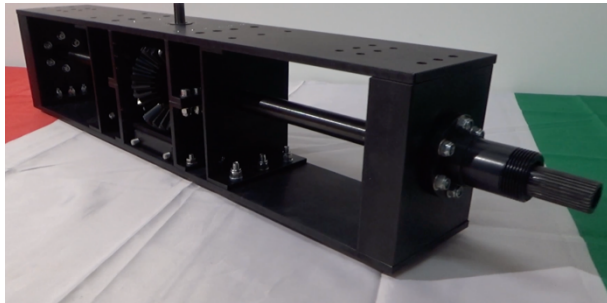

Fig. 9. Differential System assembly

5. Discussion

In conclusion, the choice of a differential system for a planetary rover based on a rocker-bogie mechanism could be the game changer in a modular platform for astronaut assistance, mechanically stable and compact optimize the space usage around the main mechanical structure.

The gearbox could also be encoderized to know the relative position of the two halves of the mobility system knowing the relative position of gears in the gearbox, using the encoder feedback a certain path that puts the rover in a position that results more critically on the main mechanical structure can be detected preventing the mechanical components to undergo cycles of high stress.

Acknowledgements

I would like to express my sincere appreciation to and gratitude to all the members of the student team DIANA from Politecnico di Torino, who work with love and passion to the development of a planetary rover technology demonstrator that has permitted the development and application of this study.

I would also to thank Politecnico di Torino and DIMEAS that funds team activities since 2008, permitting students to work on real projects improving technical skills, teamwork and collaboration.



Fig. 10. ARDITO rover developed by DIANA

References

List of references

- [1] Kassel, S. (1971). *Lunokhod-1 Soviet lunar surface vehicle* (p. 0031). Rand.
- [2] Heinicke, Orzechowski, L., & Avila, M. (2020). The MaMBA-concept for an extraterrestrial base

- and its first module mock-up. *Acta Astronautica*, 173, 404–413.
<https://doi.org/10.1016/j.actaastro.2020.04.026>
- [3] Ransan, M., & Atkins, E. M. (2006). A Collaborative Model for Astronaut-Rover Exploration Teams. In *AAAI Spring Symposium: To Boldly Go Where No Human-Robot Team Has Gone Before*(pp. 52-58).
- [4] Post, M. A., Yan, X. T., & Letier, P. (2021). Modularity for the future in space robotics: A review. *Acta Astronautica*, 189, 530-547.
<https://doi.org/10.1016/j.actaastro.2021.09.007>
- [5] Bickler, D. B. (1989). Articulated suspension system.
- [6] Woodall, Matthew & Baechler, Gunnar & Salehinia, Iman & Pohlman, Nicholas. (2020). Mars Rover Rocker-Bogie Comparative Differential Study. 9. 1874-1888.
- [7] International Organization for Standardization. (2016) Bevel and hypoid gear geometry. (BS ISO Standard No. 23509:2016).
- [8] Calle, L. M. (2019). *Corrosion on Mars: Effect of the Mars Environment on Spacecraft Materials* (No. NASA/TP-2019-220238).
- [9] International Organization for Standardization. (2021) Straight cylindrical involute splines. Metric module, side fit. Generalities (BS ISO Standard No. 4156-1:2021).
- [10] International Organization for Standardization. (2021) Straight cylindrical involute splines. Metric module, side fit. Dimensions (BS ISO Standard No. 4156-2:2021).
- [11] International Organization for Standardization. (2021) Straight cylindrical involute splines. Metric module, side fit. Inspection (BS ISO Standard No. 4156-3:2021).
- [12] International Organization for Standardization. (2014) Calculation of load capacity of bevel gears. Part 1: Introduction and general influence factors. (BS ISO Standard No. 10300-1:2014).
- [13] International Organization for Standardization. (2014) Calculation of load capacity of bevel gears. Part 2: Calculation of surface durability (pitting). (BS ISO Standard No. 10300-2:2014).
- [14] International Organization for Standardization. (2014) Calculation of load capacity of bevel gears. Part 3: Calculation of tooth root strength. (BS ISO Standard No. 10300-3:2014).
- [15] Marsh, S. (2013). How to design and install bevel gears for optimum performance: lessons learned. *Gear technology*, 30(4), 60-69.