

Energy analysis of a hybrid electro-hydraulic system for efficient mobile hydraulics

Original

Energy analysis of a hybrid electro-hydraulic system for efficient mobile hydraulics / Padovani, D; Rundo, M; Fresia, P; Altare, G. - In: JOURNAL OF PHYSICS. CONFERENCE SERIES. - ISSN 1742-6588. - ELETTRONICO. - 2648:(2023), pp. 1-14. (Intervento presentato al convegno 78° Congresso Nazionale ATI tenutosi a Carpi nel 14-15 settembre 2023) [10.1088/1742-6596/2648/1/012051].

Availability:

This version is available at: 11583/2985283 since: 2024-01-20T13:44:05Z

Publisher:

IOP Publishing

Published

DOI:10.1088/1742-6596/2648/1/012051

Terms of use:

This article is made available under terms and conditions as specified in the corresponding bibliographic description in the repository

Publisher copyright

(Article begins on next page)

PAPER • OPEN ACCESS

Energy analysis of a hybrid electro-hydraulic system for efficient mobile hydraulics

To cite this article: D Padovani *et al* 2023 *J. Phys.: Conf. Ser.* **2648** 012051

View the [article online](#) for updates and enhancements.

You may also like

- [Development of Electro - hydraulic Control Platform for High Speed Slipper Pair Friction Test Machine](#)
Lai Hu, Huaichao Wu, Limei Zhao et al.
- [A fault diagnosis method for an electro-hydraulic directional valve based on intrinsic mode functions and weighted densely connected convolutional networks](#)
Chong Shi, Yan Ren, Hesheng Tang et al.
- [Design and stability factors analysis of electro-hydraulic driving system for load-sensing electro-hydraulic robot](#)
C Y Zhang, G Z Chen, C W Miao et al.

PRIME
PACIFIC RIM MEETING
ON ELECTROCHEMICAL
AND SOLID STATE SCIENCE

HONOLULU, HI
Oct 6-11, 2024

Abstract submission deadline:
April 12, 2024
Learn more and submit!

Joint Meeting of
The Electrochemical Society
•
The Electrochemical Society of Japan
•
Korea Electrochemical Society

Energy analysis of a hybrid electro-hydraulic system for efficient mobile hydraulics

D Padovani¹, M Rundo², P Fresia³ and G Altare³

¹ Department of Mechanical Engineering and Robotics, Guangdong Technion-Israel Institute of Technology, 241 Daxue Rd., 515063, Shantou, Guangdong, China

² Department of Energy, Politecnico di Torino, C.so Duca degli Abruzzi 24, 10129, Turin, Italy

³ Manitowoc Crane Group Italy S.r.l., 12060, Niella Tanaro, Italy

Corresponding Author: Damiano Padovani, damiano.padovani@gtiit.edu.cn

Abstract. Energy efficiency plays a significant role in mobile hydraulics due to the high amount of carbon dioxide and pollutants being released into the atmosphere. Efficiency improvements are urgently needed, so the electrification of mobile hydraulics represents a fantastic opportunity in this regard. This approach leads to electro-hydraulic systems that remove functional flow throttling in control valves and enable energy recovery. Fuels savings were already demonstrated in simulation, but the literature does not offer entire energy analyses of these electro-hydraulic solutions. This limitation prevents complete system-level comprehension and does not give enough insight to pinpoint areas for further efficiency improvements. Thus, this paper focuses on a hybrid system for excavators based on electro-hydraulic drives that is compared against the original valve-controlled layout. The objective is to quantify the energy flows insight the excavator during relevant operations and highlight the resulting energy losses. The outcomes confirm that electro-hydraulic solutions are suitable for a low-carbon economy. They indicate hydraulic actuators, speed-controlled pumps, and electric motors as the critical components for further energy efficiency enhancement excluding the combustion engine.

1. Introduction

Mobile hydraulics is a necessary technology in energy-intensive fields such as construction and earth-moving, where excavators and wheel loaders are among the most popular applications. Even if many system architectures were developed over the last decades [1-2], environmental and economic motivations still call for improvements of their energy efficiency. The average value in state-of-the-art machines is remarkably poor due to functional flow throttling in control valves and absence of energy recovery. The literature reports, for instance, a 12.5% efficiency for a 5-ton load-sensing excavator accounting the hydraulics alone [3], where control valves cause about 40% of the total power dissipation. In parallel to efficiency-related issues, emission regulations for combustion engines have recently been introduced in many countries (*e.g.*, Stage V in Europe or EPA Tier 4 Final in the U.S.A.) as part of the effort to reach “carbon neutrality” in the near future. The resulting requirement of reducing fuel consumptions in mobile hydraulics generated several research outputs. Crucial approaches are about recovering energy mainly from the boom and swing actuators and mitigating the sharp spikes of the power requirements placed on the combustion engine [4]. Different hybrid systems explored the use of



hydro-pneumatic accumulators [5] and batteries and/or supercapacitors [6] even if functional power losses in control valves are still needed for linear actuators. Thus, throttleless alternatives were considered such as displacement-controlled excavators despite the inefficient behavior of the pumps at partial displacement and the costly set-up with, at least, 4 overcenter pumps. A nonhybrid version used only 50% of the input energy required by the original, load-sensing machine [3], while additional fuel savings close to 17% were predicted for its hybrid development [7]. A hybrid active-passive system was proposed for the boom drive to hydraulically support an electro-mechanical actuator [8]. This combination achieves good efficiency but might have severe limitations in heavy-duty operations [9]. Leveraging the machine electrification even more leads to efficiently controlling the motion of hydraulic actuators coupled to speed-controlled pumps that are driven by electric motors (*i.e.*, valveless actuation and energy recovery take place). These electro-hydraulic drives can successfully replace conventional control valves in terms of both dynamic response [10] and energy efficiency [11-12]. They can also come with passive load-holding devices for safety reasons [13-14], or torque-limiting designs to downsizing the rated power of the electric motors at the expense of adding extra components [15-16]. Reducing the installed electric power can also be achieved by transferring power to/from the actuators both hydraulically and electrically with a high-pressure rail supplied by a centralized pump [17-18]. Despite the individual nature, electro-hydraulic drives are suitable for multi-actuator systems [19]. They were considered for the main actuators of a 9-ton excavator [20] increasing its efficiency up to 8.8-14.5% depending on the system design, whereas the load-sensing baseline was limited to 5.4%. However, these savings were demonstrated in simulation without offering complete energy analyses that support a deeper system-level comprehension of these electro-hydraulic solutions. Such a limitation prevents pinpointing areas for further efficiency improvements, so this research paper closes this gap. We focus on a hybrid system for excavators based on electro-hydraulic drives that is compared against the original valve-controlled layout. The objective is to quantify the energy flows insight the excavator during representative operations and highlight the resulting energy losses. The outcomes give useful guidelines to steer the research applied to energy-efficient mobile hydraulics in favor of reducing fuel consumptions and exhaust emissions.

2. System design

In this study, we compare a state-of-the-art hydraulic excavator (*i.e.*, a load-sensing, valve-controlled layout) against a hybrid solution based on throttleless electro-hydraulic drives.

2.1. System architecture of the reference valve-controlled excavator

The reference system considered in this paper is a 9-ton commercialized excavator based on a load-sensing system with flow sharing [21]. The hydraulics is split into two subsystems with dedicated pumps that are driven by the combustion engine with rated power of about 50 kW. The variable-displacement pump (P_1) supplies six actuators, namely the boom, arm, bucket, left and right tracks, and boom swing. The only exceptions are the swing and blade actuators that are fed by the fixed-displacement pump (P_2). The proportional direction control valves (PDCVs) controlling the actuators' motion are combined in a stack reported in **Figure 1**, where the sections outside the scope of this study are omitted. The inlet section is connected to the variable-displacement pump. It contains the unloading valve (UV) for discharging the pump flow to reservoir during machine stand-by and the pressure-relief valve (RV_1) needed for safety reasons (the pump's displacement control system is, in fact, equipped with a differential pressure limiter and a torque limiter but does not have an absolute pressure limiter). The PDCVs of the main linear actuators include a pressure compensator that keeps a constant pressure drop across the metering edge so that the velocity of each actuator is only a function of the valve command supplied by the operator. The fixed-displacement pump has its pressure-relief valve (RV_2) installed inside the swing section. The blade motion has priority over the swing actuator that includes an integrated holding brake with antishock and anticavitation valves. Then, the swing section contains the

boost valve (VB) used to increase the boom velocity when the excavator is also swinging; the pump flow not used by the swing motor is diverted to the boom actuator. Load-holding valves are installed on the boom and blade actuators, while the antishock valve (RV₃) in the outlet module is common to all the hydraulic cylinders.

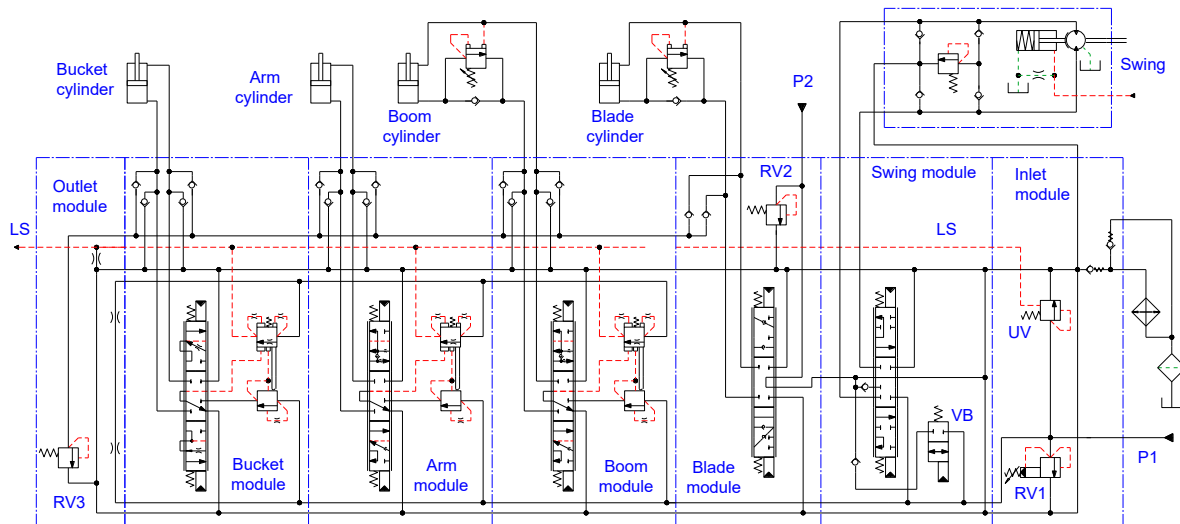

Figure 1. Simplified architecture of the reference excavator based on valve control.

2.2. System architecture of the hybrid energy-efficient excavator

This alternative system design achieves energy-efficient actuation by removing flow throttling and enabling energy recovery. Since excavators often require operations where the boom, arm, bucket, and swing actuators are operated at the same time [22], ensuring their independent control is crucial. The proposed architecture, taken from a previous study [23], is based on electro-hydraulic drives for the linear actuators and on a fully electric solution for the swing. This approach offers a suitable opportunity to electrify compact excavators due to the reduced number of components, the limited power ratings of the electric subsystem, and the simple control effort being required. It is worth mentioning that all the actuators' power must be managed by the electric machines and generated onboard by the combustion engine, so the compact size of the excavator makes this approach feasible.

The system layout in **Figure 2** presents an internal combustion engine (CE) that drives an electric generator (G) and two hydraulic pumps. The fixed-displacement charge pump (P₁) supplies the low-pressure system constituted by a hydro-pneumatic accumulator (A) and a pressure-relief valve (RV). The variable-displacement pump (P₂) delivers flow to some valve-controlled actuators that are rarely involved (*i.e.*, the tracks, blade, and boom-swing). This pump can be disconnected from the engine by a clutch to avoid unnecessary power losses when those actuators are unactuated. The generator charges a supercapacitor-based battery (S) that feeds four electric motors (EMs). The motors EM₁, EM₂, and EM₃ drive hydraulic motors/pumps integrated into the electro-hydraulic subsystems of the boom, arm, and bucket actuators, respectively. The open-circuit configuration for the boom drive can achieve higher energy efficiency compared to the closed-circuit alternative [12] where both actuator's chambers are permanently connected to the pump/motor ports. Thus, the pump/motor P₃ sets the boom velocity, while the nonproportional 4/3 direction control valve (DCV) selects the motion direction. Its tank port is connected to a preloaded check valve to keep a low back pressure that avoids cavitation and increases the actuator's stiffness. The arm and bucket drives use two pumps/motors each because this system design is free of instable mode switching (*i.e.*, switching elements such as pilot-operated check valves are removed). In fact, mode switching might take place in single pump-drives [24-25] and is improper for safe and effective operations (the high-pressure side migrates from one actuator chamber to the other continuously and abruptly switching, therefore, the drive operation between pumping and motoring

configuration due to the corresponding opening/closing of the pilot-operated check valves). Simple check valves (CVs) connect the charge line to the actuators' chambers removing the risk of cavitation in the long transmission lines going to the hydraulic cylinders. Finally, the motor EM₄ drives the fully electric swing using a gear ratio 145.8:1.

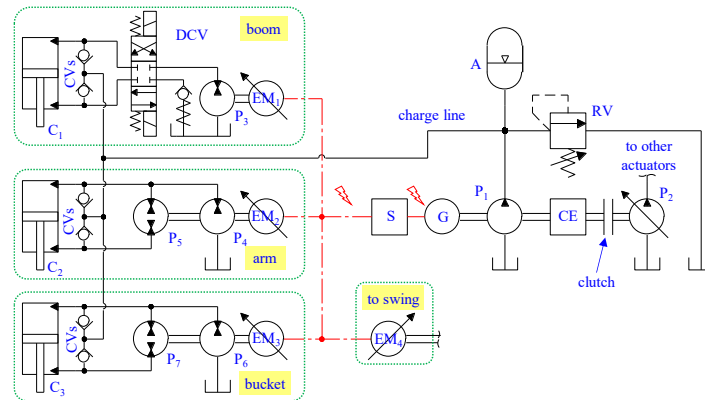

Figure 2. Simplified architecture of the energy-efficient hybrid excavator.

3. System modeling

We have created two high-fidelity dynamic models of the systems under investigation using Simcenter Amesim[®]. A brief description of these models is given hereinafter.

3.1. Modeling the reference valve-controlled excavator

The model of the reference system is a development of an experimentally validated model [21], [26]. The fuel consumption map of the engine is included (its control input is set to high-idle at about 2500 rev/min so that the speed varies according to the wide-open-throttle curve depending on the engine load). For the pumps, both volumetric and mechanical-hydraulic efficiencies are considered as a function of pressure and speed. The displacement adjustment system of the variable-displacement unit includes the real geometry of the control valves and swashplate actuators. The PDCVs' stack is simulated with the best accuracy after recreating it in a CAD environment. Tailor-made models of the boom and arm cylinders account for the end-position cushioning. The swing model includes a hydraulic motor with integrated gearbox. The excavator kinematics has been simulated using the 2D Mechanical library. Then, further updates include improvements such as the variation of the cabin inertia as a function of the arm position and newer Amesim blocks [18]. For instance, the soil/bucket interaction is accounted giving a realistic load condition due to the digging force and the adjustable filling factors of the bucket.

3.2. Modeling the hybrid energy-efficient excavator

Concerning the mathematical modeling of the energy-efficient excavator in **Figure 3**, we modified the original Amesim sketch accordingly to reflect the system architecture given in **Figure 2**. Since this approach was already described in reference [23], only the main features are recalled here. The electro-hydraulic drives are simulated using look-up tables of the electric motors that contain functional models with realistic power losses and torque limits based on the operating conditions (the same maps are used in both generator and motor mode). The electric power supply includes a quasi-static model of the supercapacitor and a generator model with constant efficiency. The latter component is engaged/disengaged by a logical switch based on the supercapacitor's state of charge (the lower and upper threshold limits are 55% and 85%, respectively). The hydraulic pumps/motors include mechanical-hydraulic and volumetric efficiencies, while all valves consider realistic flow-pressure drop characteristics (it is worth mentioning they are nonproportional components used as logic valves). The

system sizing was chosen to meet the performance of the valve-controlled excavator taken as the reference. The resulting parameters of the main components are elucidated in reference [23].

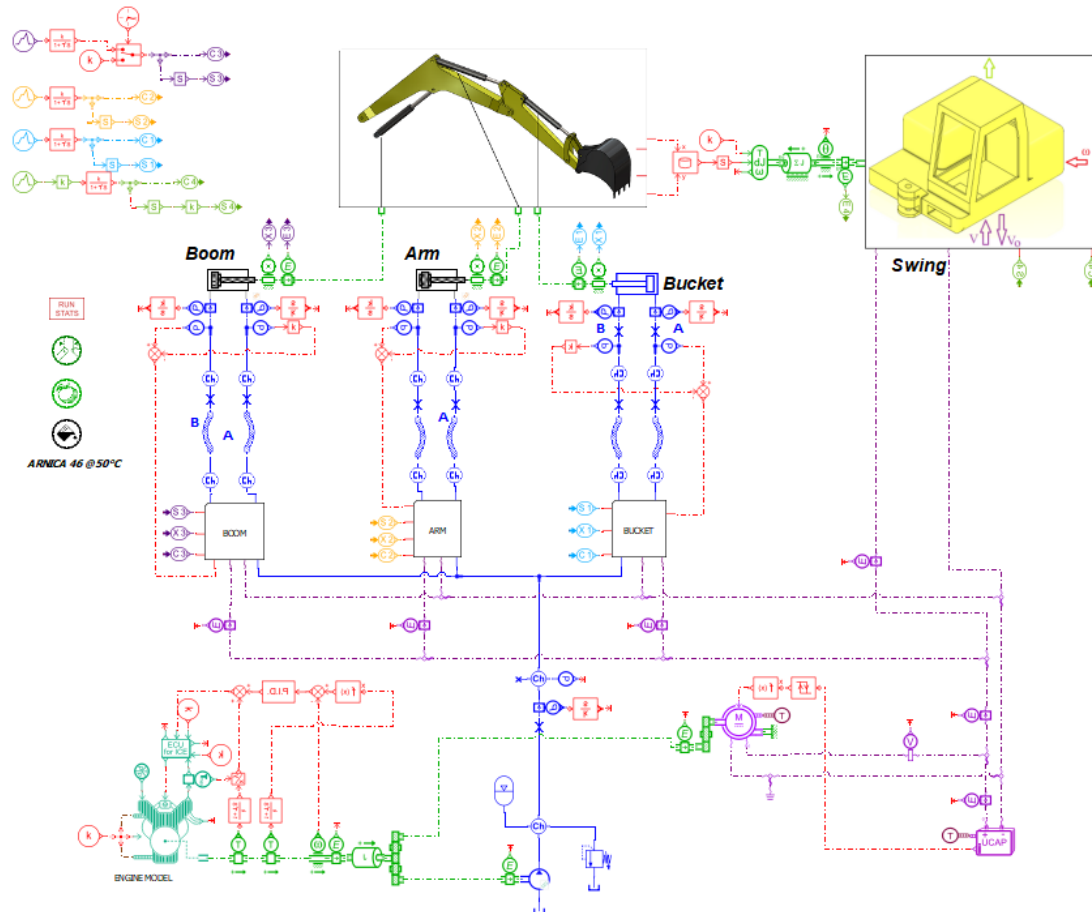

Figure 3. Amesim model of the hybrid excavator.

4. System simulation

We have used the mathematical models described above to study the two system architectures.

4.1. Reference working cycle and automated control algorithm

We have considered as the case study a common trench digging cycle based on the JCMAS regulations. **Figure 4** presents a visual representation of the excavator and the position of the actuators during the 14-second cycle. The material being moved is “well graded gravel, sandy gravel, with little or no fines” with density of 2141 kg/m^3 and labelled as GW according to the Unified Soil Classification System. It leads to demanding operating conditions due to high forces generated on the bucket tip. We have applied closed-loop position control to ensure fair comparisons between different systems. The commanded actuator positions are tracked by generating suitable speed commands for the electric motors. The electro-hydraulic drives of the boom, arm, and bucket require a PI-controller acting on the position error, feedforward command based on the desired actuator velocity, and pressure feedback to add artificial damping (a detailed description is given in reference [23]). The latter characteristic is essential because the energy-efficient nature of these drives dictates extremely low damping ratios otherwise [27]. Lastly, the swing’s fully electric drive uses the same control structure except for the lack of pressure feedback.

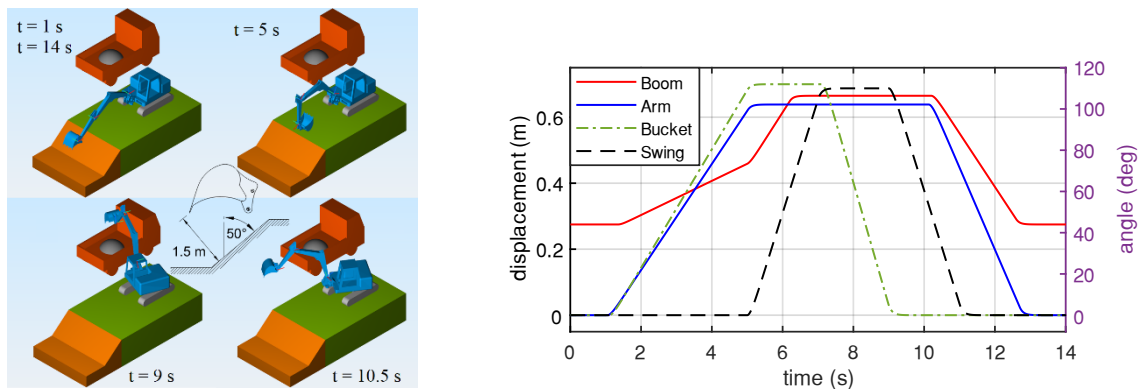

Figure 4. Excavator motion during a digging cycle and commanded actuator positions.

4.2. Comparison between the valve-controlled and energy-efficient excavators

The digging cycle introduced above has been simulated six consecutive times for the energy-efficient machine to understand the behavior of the hybrid subsystem. The overall functioning was validated in another study [23] showing that the position tracking of the actuators is satisfactory, and the pressure variations are sufficiently smooth due to the introduction of pressure feedback. Thus, the focus of this section is dual-fold: first pointing out that the comparison against the valve-controlled excavator is fair and, second, highlighting the major differences. **Figure 5** and **Figure 6** accomplish the first goal by presenting the position and the net mechanical energy of each actuator for both excavators. These trends are almost identical so that one can conclude that the excavators perform the same operation.

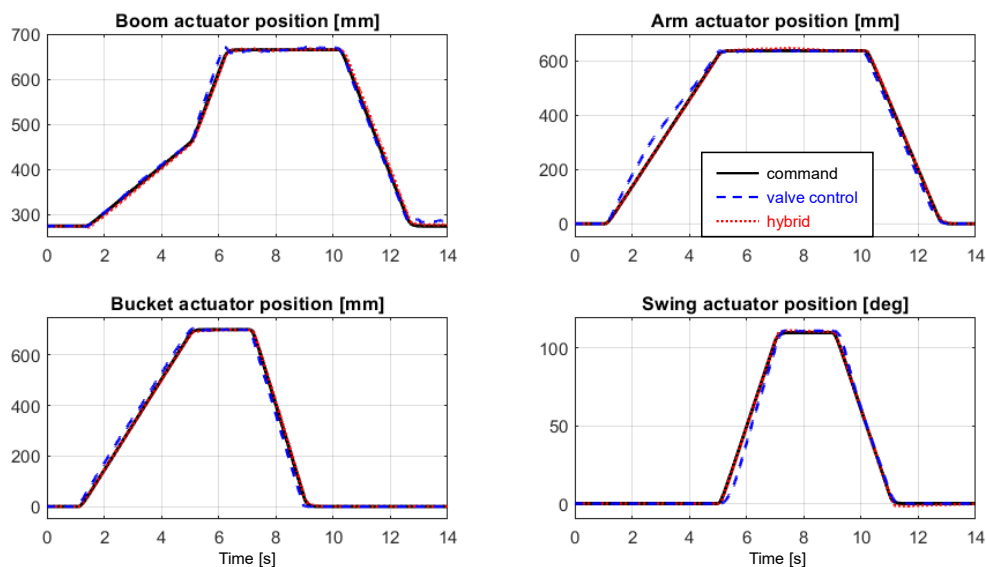

Figure 5. Actuator positions of the valve-controlled and hybrid excavators during one cycle.

Concerning the most important changes between the two excavators, **Figure 7** collects the total fuel consumption during six working cycles, the total energy lost by the systems, a rough estimation of the cumulated CO₂ emissions of the engines, and the supercapacitor's status of charge. This number of consecutive digging cycles was chosen because it causes the entire discharging and recharging of the supercapacitor (*i.e.*, starting from 85%, the status of charge goes down to 55% and then back to 85% that are the operating limits chosen to engage/disengage the electric generator that runs between 54 and 83 seconds). In terms of results for six working cycles, the hybrid machine burns 122 g against 198 g of

the original excavator (*i.e.*, fuel saving of about 38%). The resulting estimations of the CO₂ emissions are 385 and 624 g, respectively. Thus, the hybrid system dissipates 4981 kJ during the six cycles as opposed to 8147 kJ of the valve-controlled system. In the latter case, about 1165 kJ are due to functional losses in the control valves, whereas the hybrid design is only affected by parasitic losses.

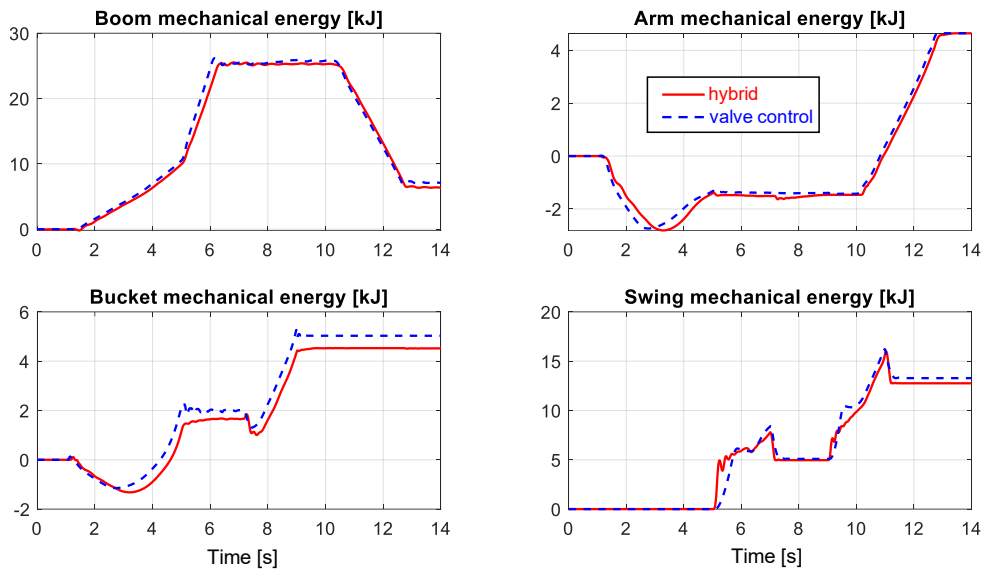

Figure 6. Actuator mechanical net energy for both excavators during one cycle.

Since the hybrid excavator starts the operations being fully charged (**Appendix A** explains this process), this extra energy should be considered to perform a fair comparison. Therefore, 129 g of fuel for loading the energy storage devices corresponding to 5410 kJ of chemical energy and 406 g of CO₂ should be included in the computations. Extrapolating the available data indicates that the hybrid excavator becomes convenient after completing 9 digging cycles that is such a small number to fully justify the migration towards this more efficient technology.

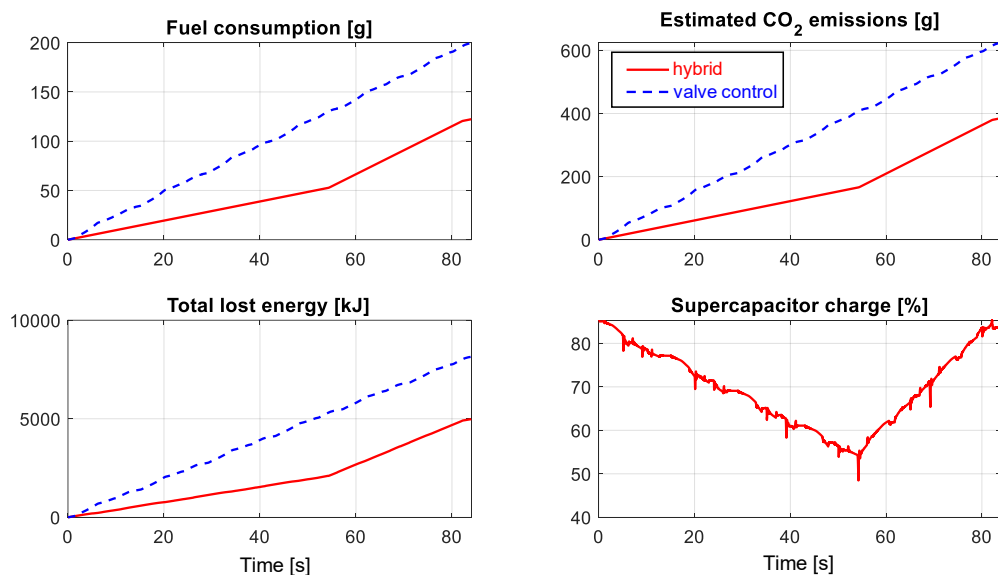

Figure 7. Valve-controlled versus hybrid excavator focusing on the consumption (six cycles).

4.3. Energy analysis of the hybrid excavator

Concerning the energy flows inside the hybrid excavator, it is worth analyzing the overall machine and the individual electro-hydraulic drives separately. **Figure 8** depicts the block diagram used to highlight the multiple energy terms inside the excavator. The chemical energy of the fuel (E_F) entering the engine is converted into mechanical energy ($E_{M,CE}$) and engine losses ($E_{L,CE}$):

$$E_{M,CE} = E_F - E_{L,CE} = E_{M,G} + E_{M,CP} . \tag{1}$$

This mechanical energy is then split into the ones entering the generator ($E_{M,G}$) and the charge pump ($E_{M,CP}$). They lead to the electric energy leaving the generator ($E_{E,G}$) and to the hydraulic energy of the charge line ($E_{H,CP}$), where the corresponding losses $E_{L,G}$ and $E_{L,CP}$ are kept into account accordingly:

$$E_{E,G} = E_{M,G} - E_{L,G} , \tag{2}$$

$$E_{H,CP} = E_{M,CP} - E_{L,CP} . \tag{3}$$

The net electric energy exchanged among the generator, supercapacitor ($E_{E,S}$), and drives leads to

$$E_{E,G} + E_{E,S} = \sum E_{E,i} = E_{E,BM} + E_{E,AR} + E_{E,BK} + E_{E,SW} , \tag{4}$$

where the index $i = BM, AR, BK, SW$ refers to the boom (BM), arm (AR), bucket (BK), and swing (SW) drives. The supercapacitor is affected by resistive losses ($E_{L,S}$), while each drive presents a total energy dissipation ($E_{L,i}$) coming from different sources. Since the drives exchange mechanical net energy ($E_{M,i}$) with the external load, Eq. (5) is valid for them all:

$$E_{E,i} = E_{M,i} + E_{L,i} . \tag{5}$$

Combining the wasted energy listed above gives the total losses of the excavator ($E_{L,TOT}$)

$$E_{L,TOT} = E_{L,CE} + E_{L,G} + E_{L,CP} + E_{L,S} + E_{L,BM} + E_{L,AR} + E_{L,BK} + E_{L,SW} , \tag{6}$$

while the total input energy of the entire system is equal to

$$E_{IN,TOT} = E_F + E_{E,S} = E_{L,CE} + E_{M,G} + E_{M,CP} + E_{E,S} + E_{L,S} . \tag{7}$$

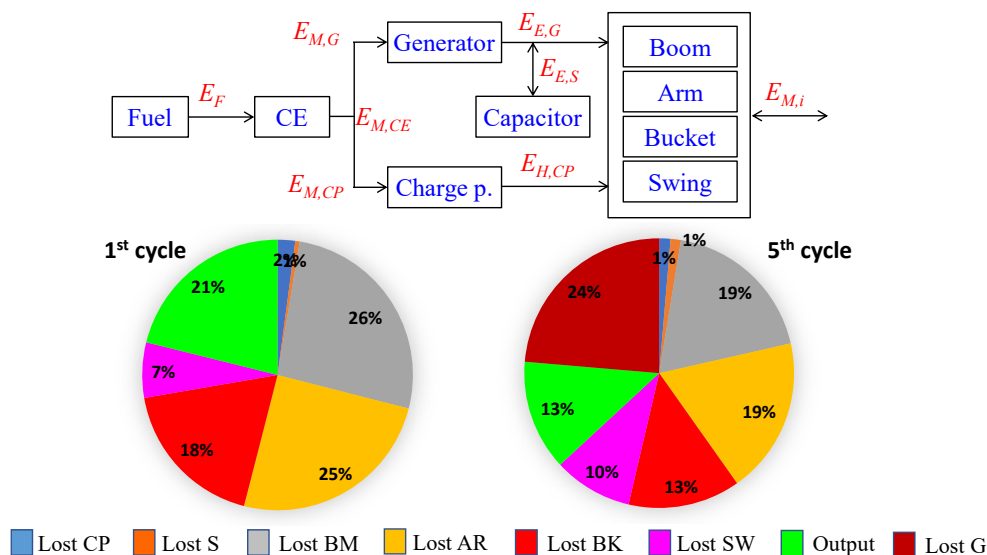

Figure 8. Block diagram of the energy flows inside the excavator and distribution of the losses.

Focusing on the drives, each input net energy ($E_{IN,i}$) and output net energy ($E_{OUT,i}$) are expressed as:

$$E_{IN,i} = E_{E,i} + E_{H,CP,i} , \tag{8}$$

$$E_{OUT,i} = E_{M,i}, \quad (9)$$

where the hydraulic power coming from the charge line ($E_{H,CP,i}$) is not relevant for the swing drive and the overall net contributions ($E_{IN,TOT}$ and $E_{OUT,TOT}$) include all four drives. The total lost energy of each drive takes into account the dissipations of the electric motor ($E_{L,EM}$), pumps ($E_{L,P}$), transmission lines and nonproportional valves if any ($E_{L,TL}$), and hydraulic actuator ($E_{L,A}$):

$$E_{L,i} = E_{IN,i} - E_{OUT,i} = E_{L,EM,i} + E_{L,P,i} + E_{L,TL,i} + E_{L,A,i}. \quad (10)$$

Considering at least two different working cycles is necessary to get a comprehensive picture, namely one cycle where the electric generator is always disengaged (e.g., the 1st cycle from 0 to 14 s) and another one where the generator is permanently functioning (the 5th cycle from 56 to 70 s). **Table 1** reports the energy losses of the key components (rows labelled as “A”) as well as their percentage with respect to the total input energy of the entire system: two cases are considered, namely including the engine losses (“B” rows) like in Eq. (7) or excluding the engine losses (“C” rows). This alternative evaluation was chosen because the combustion engine represents the main source of dissipation in any case. The CE runs all the time even when the generator is disengaged and is often used at very partial load to power the charge pump alone leading to extremely low efficiencies.

Table 1. Energy distribution in the hybrid excavator during different trench digging cycles.

		Lost engine ($E_{L,CE}$)	Lost P1 pump ($E_{L,CP}$)	Lost generator ($E_{L,G}$)	Lost capacitor ($E_{L,S}$)	Lost boom ($E_{L,BM}$)	Lost arm ($E_{L,AR}$)	Lost bucket ($E_{L,BK}$)	Lost swing ($E_{L,SW}$)	Output drives ($E_{OUT,TOT}$)
1 st cycle	A	565.8 kJ	2.8 kJ	-	0.7 kJ	35.2 kJ	33.3 kJ	24.4 kJ	8.8 kJ	28.2 kJ
	B	80.9%	0.4%	-	0.1%	5.0%	4.8%	3.5%	1.3%	4.0%
	C	-	2.1%	-	0.5%	26.3%	25.0%	18.3%	6.6%	21.1%
5 th cycle	A	1008.2 kJ	2.4 kJ	42.0 kJ	2.2 kJ	33.5 kJ	33.3 kJ	23.9 kJ	16.8 kJ	23.5 kJ
	B	85.0%	0.2%	3.5%	0.2%	2.8%	2.8%	2.0%	1.4%	2.0%
	C	-	1.4%	23.6%	1.2%	18.9%	18.8%	13.4%	9.5%	13.2%

Excluding the CE from the analysis places the focus on the hybrid system as confirmed by the pie charts in **Figure 8** based on the values from the “C” rows. We can see that the losses in the drives account for 76.1% of the input energy in the 1st cycle, while the wasted energy in the charge pump, generator, and ultracapacitor is almost negligible. Conversely, the generator plays a role in the 5th cycle (23.6% of the input energy is lost there) and the drives still consume a significant amount (60.5%) of the energy entering the system. Nevertheless, the combustion engine is the main source of losses wasting more energy alone than all the other components combined (e.g., 154 kJ versus 1008 kJ in a cycle where the electric generator is always engaged). Two strategies can improve this aspect: (1) running all the time a downsized engine (the generator would operate for most of the time), or (2) maintain a powerful engine while applying start-and-stop or minimizing its speed with electronic control (the engine would only run when the generator is needed). Such a key aspect deserves further consideration in future studies.

Focusing on the drives alone, **Table 2** lists their net energy contributions in a 14-second working cycle (any cycle is the same for the drives no matter if the generator is engaged or not). Even if energy is recovered by the boom and swing drives, the overall (net) energy flow is directed from the power supply (the energy input is electric and hydraulic from the charge line) toward the actuators (the energy output is mechanical to the external load).

Table 2. Net energy distribution inside the individual drives during one trench digging cycle.

	Net input ($E_{IN,i}$)	Net output ($E_{OUT,i}$)	Lost total ($E_{L,i}$)	Lost EM ($E_{L,EM,i}$)	Lost pump ($E_{L,P,i}$)	Lost lines ($E_{L,TL,i}$)	Lost act. ($E_{L,A,i}$)
Boom	41.5 kJ	6.4 kJ	35.2 kJ	8.1 kJ	9.0 kJ	4.6 kJ	13.5 kJ
	100%	15.3%	84.7%	19.5%	21.7%	11.1%	32.4%
Arm	37.9 kJ	4.6 kJ	33.3 kJ	5.7 kJ	9.0 kJ	5.0 kJ	13.5 kJ
	100%	12.1%	87.9%	15.0%	23.7%	13.2%	35.6%
Bucket	28.9 kJ	4.5 kJ	24.4 kJ	3.4 kJ	7.7 kJ	2.9 kJ	10.3 kJ
	100%	15.6%	84.4%	11.8%	26.7%	10.0%	35.7%
Swing	21.5 kJ	12.7 kJ	8.8 kJ	8.8 kJ	-	-	-
	100%	59.1%	40.9%	40.9%	-	-	-

For the electro-hydraulic subsystems of the boom, arm, and bucket, the losses are distributed almost evenly among the main components (**Figure 9**). The hydraulic pumps/motors play a significant role wasting about $\frac{1}{4}$ of the energy managed by each drive. Approximately another quarter of the input energy is lost in the electric motors and in the hydraulic transmission lines (the original design is still used). Finally, the hydraulic cylinders are the biggest source of losses. It is believed that a redesign can reduce these terms greatly (the cushioned actuators used in the commercial machine introduce relevant flow restrictions). In the swing drive, all the energy dissipations are related to the electric motor.

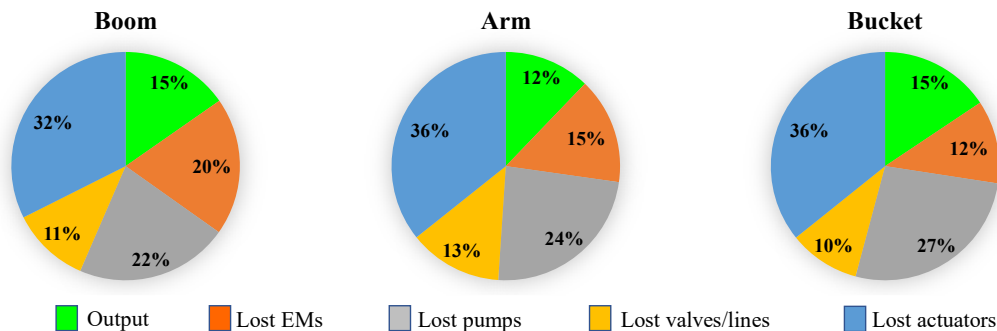
**Figure 9.** Energy distribution inside the electro-hydraulic drives during a trench digging cycle.

It is worth noting that the abovementioned energy quantities are always the net terms transferred to the load (*i.e.*, some soil is loaded onto a truck during every cycle). The same analysis can be conducted spitting the positive and negative energy contributions, where positive refers only to the energy flowing from the electro-hydraulic system to the load and negative only to the energy coming back and going to the drives. **Table 3** lists the electric energy exchanged by each motor, the mechanical energy transferred by each actuator, the hydraulic energy received from the charge line (always a positive contribution), and the resulting losses of each drive.

Table 3. Positive and negative energy of the individual drives during one cycle.

	Electric energy ($E_{E,i}$)		Mech. energy ($E_{M,i}$)		Hydraulic ($E_{H,CP,i}$)	Losses ($E_{L,i}$)		
	Positive	Negative	Positive	Negative		Positive	Negative	Net
Boom	45.9 kJ	5.6 kJ	27.4 kJ	21.2 kJ	1.2 kJ	19.5 kJ	15.6 kJ	35.1 kJ
Arm	38.0 kJ	0.2 kJ	7.8 kJ	3.2 kJ	0.1 kJ	30.3 kJ	3.0 kJ	33.3 kJ
Bucket	28.9 kJ	0.1 kJ	7 kJ	2.5 kJ	0.1 kJ	22.0 kJ	2.4 kJ	24.3 kJ
Swing	27.1 kJ	5.6 kJ	21.4 kJ	8.7 kJ	-	5.7 kJ	3.1 kJ	8.8 kJ

Only the boom and swing drive show significant recovery capabilities. They return back to the supercapacitor 5.6 kJ of electric energy each, converting the available potential and kinetic energy of the excavator (*i.e.*, 21.2 kJ from the boom and 8.74 kJ from the swing are available for recovery in each cycle). The arm and bucket drives return negligible electric energy (0.2 and 0.1 kJ, respectively) because their operations present limited opportunities for regeneration.

4.4. Energy analysis of the valve-controlled excavator

Before concluding the paper, it is useful to leverage the available results to provide a brief energy analysis of the valve-controlled excavator. **Table 4** lists the main contributions clearly showing that the combustion engine is again the main source of inefficiencies. The percentages of the losses are reported with respect to the input energy when the engine losses are included (“B” row) or excluded (“C” row). Recalling the “C” row because it is representative of the hydraulic system alone, half of the mechanical energy of the engine is lost in the block of the PDCVs. The second most predominant dissipation (16.4%) is due to the piston pump that supplies the boom, arm, and bucket actuators and it is followed by the losses inside the actuators (12.9%). The transmission lines, that include the load-holding valve of the boom actuator, still take away significant energy (9.3%), while the gear pump dedicated to the swing subsystem has a small effect (4.4%). Finally, only 7.7% of the energy delivered by the engine is transferred to the external load. Since energy recovery is not realized (*i.e.*, the 35.4 kJ made available by the actuators must be dissipated), the latter percentage can be seen as an average energy efficiency of the entire hydraulic system.

Table 4. Energy distribution of the valve-controlled excavator during a trench digging cycle.

	Lost CE	Lost pump P ₁	Lost pump P ₂	Lost PDCVs	Lost lines	Lost actuators	Net drives	Pos. drives	Neg. drives
A	995.6 kJ	64.1 kJ	17.2 kJ	194.1 kJ	36.3 kJ	50.5 kJ	30.1 kJ	65.5 kJ	35.4 kJ
B	71.8%	4.6%	1.2%	14.0%	2.6%	3.6%	2.2%	-	-
C	-	16.4%	4.4%	49.6%	9.3%	12.9%	7.7%	-	-

5. Conclusions

The focus of this research paper is on the critical aspect of improving the energy efficiency of mobile hydraulics by supporting its electrification. The investigation is about a hybrid electro-hydraulic excavator that removes functional losses and recovers energy. The energy analysis developed in this study supports a deeper system-level comprehension of these electro-hydraulic solutions. The energy flows inside the excavator are tracked during a representative digging cycle and the resulting energy dissipations are highlighted. The main conclusions are therefore summarized as follows:

- 1) The combustion engine is the main source of losses wasting more energy alone than all the other components combined. Employing start-and-stop operations or permanently running a downsized unit can lead to significant fuel savings.
- 2) Excluding the engine, most of the losses (roughly two-thirds) take place in the electro-hydraulic drives due to the inefficiencies of the components. When the electric generator is running, it dissipates relevant energy close to one-quarter of the total losses.
- 3) Inside the electro-hydraulic drives, the hydraulic cylinders are surprisingly the biggest source of lost energy close to one-third of the total (it is believed a redesign can reduce this term greatly). The hydraulic pumps and the electric motors still contribute up to one-quarter of the total each.
- 4) All electro-hydraulic drives return some electric energy back to the supercapacitor. Due to the operations being performed, only the boom and swing drive show real recovery (5.6 kJ each).
- 5) The hybrid excavator ensures fuel savings of about 38% compared to the valve-controlled machine in a sequence of 6 digging cycles assuming a fully charged initial status of the energy

storage device (6 cycles are considered because they are the required quantity to cause the complete discharge and successive recharge of the supercapacitor). Moreover, hybrid excavator usage in real-world applications is feasible since it outperforms the conventional machine after completing about 9 digging cycles when a completely discharged initial status of the energy storage device is assumed.

- 6) The energy analysis of the valve-controlled excavator confirms previous results available in literature. Half of the mechanical energy of the engine is lost in the valve block as functional losses and only 7.7% of that input energy is transferred to the external load.

In conclusion, this paper shows that implementing hybrid excavators based on electro-hydraulic drives is possible without affecting the machine performance. This approach is also convenient in terms of fuel consumption and CO₂ emissions. Some areas for further improvements are also pinpointed to support the electrification process of mobile hydraulics aligned with the low-carbon economy.

Appendix A

This section addresses the charging operation of the energy storage devices in the hybrid excavator starting from a completely empty condition without commanding any motion to the actuators. This case represents an extreme condition that does not take place regularly because the hybrid subsystem is sized to meet the demand of regular working cycles without discharging entirely. However, this charging operation is completed in less than one minute (**Figure 10**) and does not limit the normal usage of the machine due to its very short duration. The hydraulic accumulator is loaded completely in about 19 s, while the ultracapacitor takes 53 s to reach 85% of the total charge (this value is the maximum admitted one when charging it with the electric generator). The resulting fuel consumption is almost 129 g corresponding to a chemical input energy of 5410 kJ, while the combustion engine releases approximately 406 g of CO₂ into the atmosphere.

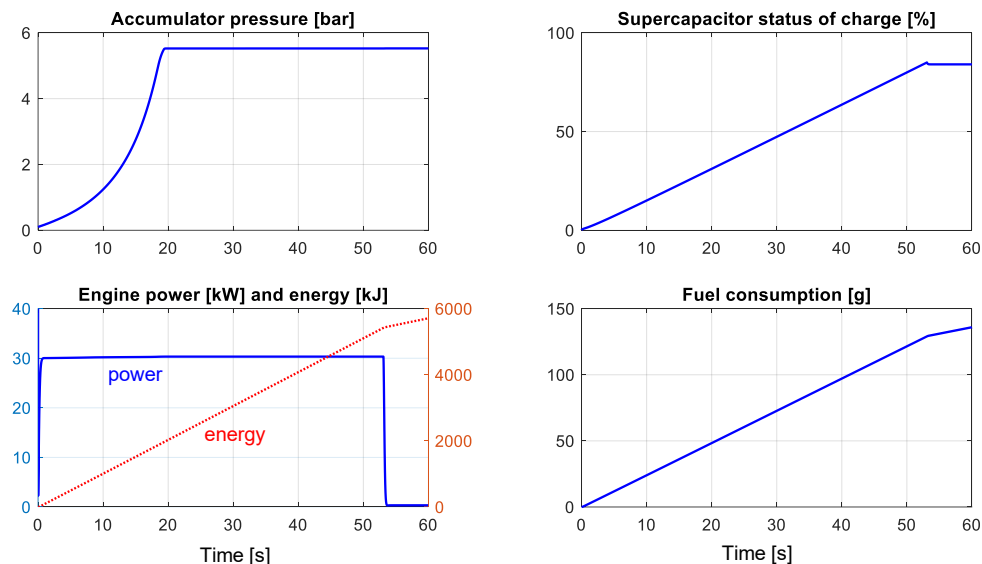

Figure 10. Charging of the energy storage devices without any motion of the actuators.

References

- [1] D. Padovani, M. Rundo, and G. Altare, "The Working Hydraulics of Valve-Controlled Mobile Machines: Classification and Review," *ASME J. Dyn. Syst. Meas. Control*, vol. 142, no. 7, 2020, doi: 10.1115/1.4046334.
- [2] A. Bedotti, M. Pastori, and P. Casoli, "Modelling and energy comparison of system layouts for a hydraulic excavator," *Energy Procedia*, vol. 148, 2018, doi: 10.1016/j.egypro.2018.08.015.

- [3] J. Zimmerman and M. Ivantysynova, "Reduction of engine and cooling power by displacement control," *6th FPNI-PhD Symposium*. West Lafayette, IN, USA, 2010.
- [4] A. Hiebl and R. Scheidl, "Energy Consumption and Efficiency Measurements of Different Excavators: Does Hybridization Pay?," *ASME/BATH Symposium on Fluid Power and Motion Control*, Chicago, USA, 2015.
- [5] P. Casoli, A. Gambarotta, N. Pompini, and L. Riccò, "Hybridization methodology based on DP algorithm for hydraulic mobile machinery - Application to a middle size excavator," *Autom. Constr.*, vol. 61, pp. 42–57, 2016, doi: 10.1016/j.autcon.2015.09.012.
- [6] H. Wang, Q. Wang, and B. Hu, "A review of developments in energy storage systems for hybrid excavators," *Automation in Construction*, vol. 80. Elsevier B.V., pp. 1–10, Aug. 01, 2017, doi: 10.1016/j.autcon.2017.03.010.
- [7] R. Hippalgaonkar, M. Ivantysynova, and J. Zimmerman, "Fuel savings of a mini-excavator through a hydraulic hybrid displacement controlled system," *8th International Fluid Power Conference*. Dresden, Germany, 2012.
- [8] Z. Li, C. Wang, L. Quan, Y. Hao, L. Ge, and L. Xia, "Study on energy efficiency characteristics of the heavy-duty manipulator driven by electro-hydraulic hybrid active-passive system," *Autom. Constr.*, vol. 125, no. February, 2021, doi: 10.1016/j.autcon.2021.103646.
- [9] D. Hagen, D. Padovani, and M. Choux, "Guidelines to Select Between Self-Contained Electro-Hydraulic and Electro-Mechanical Cylinders," *15th IEEE Conference on Industrial Electronics and Applications*. Kristiansand, Norway, 2020, doi: 10.1109/ICIEA48937.2020.9248373.
- [10] D. Hagen, D. Padovani, and M. Choux, "A Comparison Study of a Novel Self-Contained Electro-Hydraulic Cylinder versus a Conventional Valve-Controlled Actuator — Part 1: Motion Control," *Actuators*, vol. 8, no. 79, 2019, doi: 10.3390/act8040079.
- [11] D. Hagen, D. Padovani, and M. Choux, "A Comparison Study of a Novel Self-Contained Electro-Hydraulic Cylinder versus a Conventional Valve-Controlled Actuator — Part 2: Energy Efficiency," *Actuators*, vol. 8, no. 78, 2019, doi: 10.3390/act8040078.
- [12] S. Qu, D. Fassbender, A. Vacca, and E. Busquets, "A High-Efficient Solution for Electro-Hydraulic Actuators with Energy Regeneration Capability," *Energy*, vol. 216, 2021, doi: 10.1016/j.energy.2020.119291.
- [13] D. Padovani, S. Ketelsen, D. Hagen, and L. Schmidt, "A Self-Contained Electro-Hydraulic Cylinder with Passive Load-Holding Capability," *Energies*, vol. 12, no. 2, 2019, doi: 10.3390/en12020292.
- [14] D. Hagen and D. Padovani, "A Method for Smoothly Disengaging the Load-Holding Valves of Energy-Efficient Electro-Hydraulic Systems," *1st International Electronic Conference on Actuator Technology: Materials, Devices and Applications*, 2021, doi: 10.3390/iecat2020-08478.
- [15] D. Padovani, S. Ketelsen, and L. Schmidt, "Downsizing the electric motors of energy-efficient self-contained electro-hydraulic systems by using hybrid technologies," *Bath/ASME Symposium on Fluid Power and Motion Control*. Bath, UK, 2020.
- [16] J. Beale and D. Padovani, "A Dual-Pump Energy-Efficient Electro-Hydraulic Drive with Extended Velocity Range," *9th International Conference on Mechatronics and Robotics Engineering (ICMRE)*. Shenzhen, China, 2023, doi: 10.1109/ICMRE56789.2023.10106608.
- [17] P. Y. Li, J. Siefert, and D. Bigelow, "A hybrid hydraulic-electric architecture (HHEA) for high power off-road mobile machines," *ASME/BATH Symposium on Fluid Power and Motion Control*. Longboat Key, FL, USA, 2019.
- [18] P. Fresia, M. Rundo, D. Padovani, and G. Altare, "Combined Speed Control and Centralized Power Supply for Hybrid Energy-Efficient Mobile Hydraulics," *Autom. Constr.*, vol. 140, no. February, 2022, doi: 10.1016/j.autcon.2022.104337.
- [19] D. Hagen, D. Padovani, and M. Choux, "Enabling Energy Savings in Offshore Mechatronic Systems by using Self-Contained Cylinders," *Model. Identif. Control*, vol. 40, no. 2, 2019, doi: 10.4173/mic.2019.2.2.
- [20] P. Casoli, F. Scolari, T. Minav, and M. Rundo, "Comparative energy analysis of a load sensing

- system and a zonal hydraulics for a 9-tonne excavator,” *Actuators*, vol. 9, no. 2, Jun. 2020, doi: 10.3390/ACT9020039.
- [21] G. Altare, D. Padovani, and N. Nervegna, “A Commercial Excavator: Analysis, Modelling and Simulation of the Hydraulic Circuit,” *SAE COMVEC*. Rosemont, IL, USA, 2012, doi: 10.4271/2012-01-2040.
- [22] C. Williamson, J. Zimmerman, and M. Ivantysynova, “Efficiency Study of an Excavator Hydraulic System Based on Displacement-Controlled Actuators,” *ASME/BATH Symposium on Fluid Power and Motion Control*, 2008.
- [23] D. Padovani, P. Fresia, M. Rundo, and G. Altare, “Downsizing the Electric Machines of Energy-Efficient Electro-Hydraulic Drives for Mobile Hydraulics,” *Journal of Physics: Conference Series*, 2022, doi: 10.1088/1742-6596/2385/1/012028.
- [24] C. Williamson and M. Ivantysynova, “Stability and Motion Control of Inertial Loads with Displacement Controlled Hydraulic Actuators,” in *6th FPNI - PhD Symposium*, 2010.
- [25] P. Gøytil, D. Padovani, and M. Hansen, “A Novel Solution for the Elimination of Mode Switching in Pump-Controlled Single-Rod Cylinders,” *Actuators*, vol. 9, no. 20, 2020, doi: 10.3390/act9010020.
- [26] G. Altare, D. Padovani, and N. Nervegna, “A Close-up View of a Load Sensing ‘Hybrid’ Proportional Directional Control Valve,” *JFPS Int. J. Fluid Power Syst.*, vol. 6, no. 1, 2013, doi: 10.5739/jfpsij.6.8.
- [27] D. Padovani, “Adding Active Damping to Energy-Efficient Electro-Hydraulic Systems for Robotic Manipulators — Comparing Pressure and Acceleration Feedback,” *5th International Conference on Robotics and Automation Engineering*, 2020.