

A Low Cost Compact Output Amplifier for Multichannel Muscle Stimulation

Original

A Low Cost Compact Output Amplifier for Multichannel Muscle Stimulation / RUO ROCH, Massimo; Martina, Maurizio. - ELETTRONICO. - 866 LNEE:(2022), pp. 293-299. (Intervento presentato al convegno International Conference on Applications in Electronics Pervading Industry, Environment and Society tenutosi a Pisa, Italy nel 21-22 settembre 2021) [10.1007/978-3-030-95498-7_41].

Availability:

This version is available at: 11583/2972224 since: 2022-10-11T14:38:46Z

Publisher:

Springer

Published

DOI:10.1007/978-3-030-95498-7_41

Terms of use:

This article is made available under terms and conditions as specified in the corresponding bibliographic description in the repository

Publisher copyright

Springer postprint/Author's Accepted Manuscript (book chapters)

This is a post-peer-review, pre-copyedit version of a book chapter published in International Conference on Applications in Electronics Pervading Industry, Environment and Society. The final authenticated version is available online at: http://dx.doi.org/10.1007/978-3-030-95498-7_41

(Article begins on next page)

A low cost compact output amplifier for multichannel muscle stimulation

Massimo Ruo Roch and Maurizio Martina

Politecnico di Torino, Dipartimento di Elettronica e Telecomunicazioni

Abstract. Functional Electrical Stimulation (FES) is a technique widely used in different application fields. Among them, rehabilitation treatments, sports training activity and aesthetics. A critical component in FES is the output amplifier, which must be designed to accomplish both functional and safety specifications. In this paper, a novel power amplifier architecture with current controlled output is presented, specifically tailored to FES needs, but optimized to reduce cost and size, as needed in a multichannel electrical stimulator. The output amplifier topology, and the techniques adopted to satisfy both functional and safety specifications are herein detailed. Simulation and real circuit results are included, too.

Keywords: Functional electrical stimulator (FES), Output amplifier, Rehabilitation

1 Introduction

Neuromuscular stimulation, also known as FES (Functional Electrical Stimulation) is a well known approach to rehabilitation [1][2]. Its application to spinal chord injury (SCI) treatment helps to strengthen muscles, reduce their atrophy, spasticity, and also bone demineralization [3]. The same technique find applications in sport training, where it is used to increase strength and/or cool-down after intense work-out sessions [4]. Last, the same approach is widely used in aesthetics and aesthetic medicine, where this kind of treatment is used to shape customer's body through an increase of muscles tone.

FES is obtained applying conveniently shaped currents to the neuromuscular tissue of the muscle. These currents are usually transmitted to the muscle through skin electrodes, and, as a consequence, the impedance which must be driven is relatively high, ranging from 500Ω to $2k\Omega$ [5].

The current used to obtain muscle contraction must be adjustable from few mA up to some tens of mA, due to the great variability in muscle sensitivity (depending from muscle extension, too), and the desired contraction level [6].

With the impedances stated above, it means that voltage levels must vary from few Volts up to one hundred Volts. The output signal can be unipolar or bipolar. The latter is preferred, as it avoid charge imbalance inside the tissue, or electrodes polarization effects, which can be both painful and harmful.

Last, special care must be adopted, from the point of view of safety, as electrodes are directly connected to the patient, and the risk of electrocution must be minimized. For this reason, regulations impose strong isolation of the outputs from the AC lines and from earth. Generation of excessive voltages and currents must be prevented by-design, too.

Accordingly to the requirements described above, a typical FES device is built-up by a low voltage signal generator, and a high voltage power amplifier. The first one can be a simple relaxation oscillator, or a microprocessor driving a digital-to-analog converter (DAC). The power amplifier is a discrete-based circuit, designed to generate voltage or current outputs. The second topology is typically preferred, as it better adapts to the unknown and varying impedance at the electrode-skin interface [7].

Several circuits and topologies are described in literature. Simplest ones are just pulse generators based on inductive charge ([3] [8] [9]). A second family of circuits is represented by discrete components implementation of current mirrors. They can either be unipolar, followed by a four switch bridge to invert the current in the load [10], or fully symmetric ones [11]. Anyway, they do not fully accomplish system specification, lacking flexibility in signal generation (pulse generators), or missing safety characteristics. Moreover, they are not optimized for power consumption or size, and need to be improved.

To overcome these pitfalls, a novel circuit has been designed, with the following characteristics:

- Open-loop design, to guarantee stability with varying loads
- Scalable design, adaptable to different environments (fixed/portable/battery-operated)
- Low cost and small size. As the design must be compatible to a multichannel design, cost and size optimization is mandatory
- Safety by-design. As electrodes are directly attached to human body, fault conditions must guarantee that no injury can be caused to the patient.
- Arbitrary output waveform. This feature allows to apply the designed stimulator to different research fields, too, where experimental waveforms can be used.

2 Circuit description

The solution proposed is based on a tight coupling of the low voltage signal generator with the output amplifier. This result is obtained using a mixed signal MCU driving a current amplifier built with discrete components. The resulting block architecture is visible in figure 1. The MPU, the DAC, the comparator and operational amplifier inside the dashed rectangle are included in the selected MCU, and are separately drawn just for clarity.

The microprocessor contains the program able either to synthesize, or to store in a table, the samples of the signals to be generated. These samples are sent to the integrated DAC, and converted to a low amplitude analog signal.

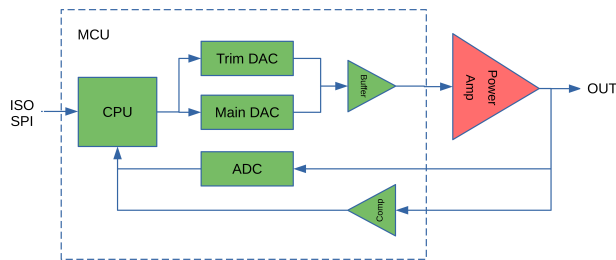

Fig. 1. Basic architecture of the system

Optionally, the microprocessor can receive configuration data from an isolated SPI interface.

The DAC output is sent to an operational amplifier, used to accomplish two different tasks. The first one is to have a higher current available to drive the input stage of the output amplifier, described below. The second task is to sum a DC voltage, used to cancel offsets present in the output amplifier, due to components tolerances and temperature and/or aging induced drifts.

An ADC continuously monitor output voltage, and the microprocessor average it to extract DC components. The result is used to generate a further DC voltage injected in the operational amplifier driving the power amplifier, to fully cancel output offset. This offset is not digitally added to the main DAC output, to avoid an output dynamic range reduction. Instead, it is sent to a secondary DAC, used to finely regulate output DC level.

Last, a solid state relay, not shown in the figure, connects the power amplifier output to the load, allowing complete disconnection of the electrodes from electronics. For safety concerns, this switch is turned off by default.

2.1 Power output amplifier

The output amplifier is a fully symmetric, open-loop, transconductance amplifier, shown in figure 2. The topology is class B, to reduce power dissipation.

Due to design symmetry, the circuit analysis can start considering only the upper half, which generates currents flowing to the load.

The input voltage is first level shifted by the diode-connected transistor Q_1 , and then applied to the base of Q_3 . This device is configured as a current generator, through the introduction of the emitter resistance R_4 . Its collector current is approximately V_{IN}/R_4 .

Transistor Q_1 has a twofold usage. First, it adds its V_{BE} voltage to the input value, to reduce crossover distortion. In fact, Q_3 is slightly polarized, even with an input voltage equal to zero. Second, the V_{BE} of Q_1 varies with temperature changes, and compensates thermal drift of Q_3 V_{BE} , improving overall thermal stability. A remarkable point is that only Q_3 temperature is relevant for output current change, as Q_5 and Q_9 mutually compensates. R_1 , biasing Q_1 , set the quiescent current of the amplifier.

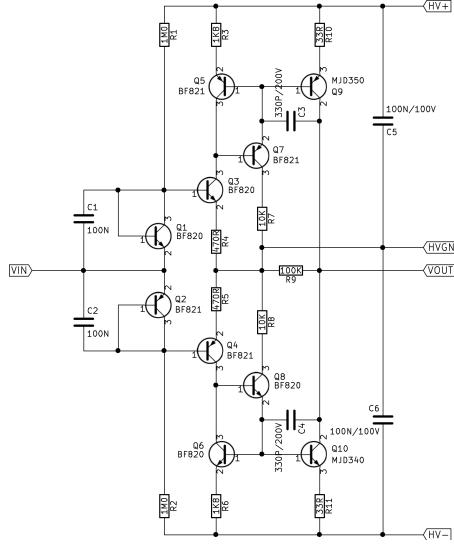

Fig. 2. Detailed schematic of the output power amplifier

C_1 , shorting Q_1 , is used to improve large signal transient response, e.g., when a square wave is sent to the input.

Q_3 collector current feeds a current mirror composed by Q_5 , Q_7 , and Q_9 . Q_5 and Q_9 are the effective mirror pair, with current amplification given by the ratio R_3/R_{10} . Q_7 instead, is a current buffer, used to minimize the impact of the low current gain of the output power transistor Q_9 . Without it, current ratio error would be unacceptable.

A Wilson topology would not be acceptable in this circuit, due to the asymmetries between weak and strong side of the mirror. This asymmetry is mandatory, to reduce power dissipation in the weak side.

Resistor R_7 is used to protect Q_7 in case of an open circuit on the output, which can by all means happen, as skin electrodes can be easily detached. In this case, without R_7 , the current through Q_7 will be $(H_{V+} - V_{BE})/R_{10}$, as Q_9 is no more a transistor but only a diode represented by its base-emitter junction. This current will create enough power dissipation to damage Q_7 . The introduction of R_7 , instead, limits the current in Q_7 to $(H_{V+} - V_{BE})/(R_{10} + R_7)$, decreasing it by three orders of magnitude.

As a drawback, the turn on time of the power output transistor Q_9 is slightly increased, as R_7 limits the maximum current available to turn it on to few mA's. Anyway, as will be shown later, the resulting rise and fall time are more than sufficient for an effective muscle stimulation.

Capacitor C_3 , across the base-collector junction of Q_9 , is used to improve circuit stability in some rare conditions of a highly reactive load, again without a significant impact on overall amplifier bandwidth.

The same considerations applies for the lower half of the circuit, which sinks current from the load. Due to symmetry, the output current is given by the difference between Q_9 and Q_{10} collector currents.

2.2 Safety countermeasures

Several different techniques are introduced, to guarantee circuit safety in any condition:

- Output amplifier fault. The output voltage of the current amplifier is continuously monitored, and if its DC value is out of range, the output is disconnected from the load through the solid state relay.
- Power supply rail failure. The power supply rails are monitored by two channels of the ADC, and the electrodes are disconnected if the read values are too far from the nominal one.
- Microcontroller firmware fault. A hardware watchdog monitors the correct execution of the application firmware, and, in case of a software malfunction, it resets the microcontroller, turning off the output solid state relay, too.
- Application software erroneous configuration. A hardware comparator is connected, through a low pass passive filter, to the output of the power amplifier. If the generation of a waveform with erroneous parameters is detected, then the comparator trigger an event, disabling the output switch.

3 Physical implementation and results

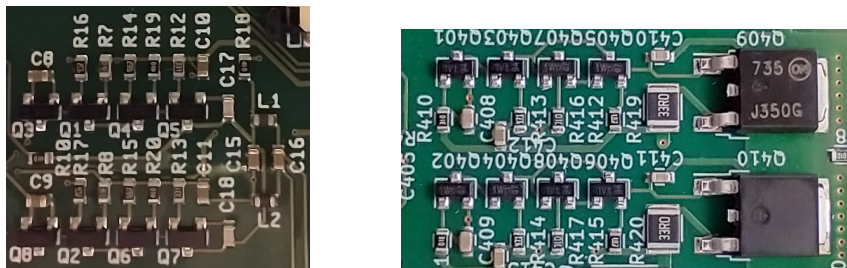

Fig. 3. Low power (left) and high power (right) version of the power amplifier

An important feature of the designed circuit is its scalability. In fact, it can be easily adapted to different current and voltage levels, just changing the BJTs, without any topology changes. To demonstrate it, two different circuits have been implemented, one for a portable, single channel, battery operated device, and the second for an AC powered multichannel stimulator. Photos of the power amplifier section of the two circuits are represented in figure 3 and dimensions are 18mm x 20mm and 32mm x 20mm, respectively. The low power version has

a 40mA, 48V output limit, while the high power one can reach 100mA, 120V output.

Simulated and measured waveforms for a large signal pulse are shown in figure 4. The oscilloscope photo shows a bipolar pulse of 110mA peak-to-peak on a load of 1kOhm. Pulse duration is 440 μ s.

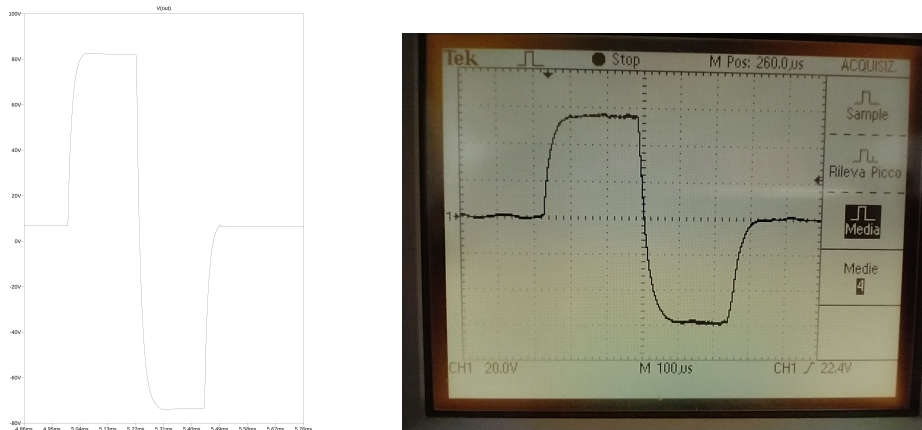

Fig. 4. Simulated (left) and measured (right) output waveforms

References

1. M. Badran and M. Moussa, "BioMEMS implants for neural regeneration after a spinal cord injury," 2005 International Conference on MEMS,NANO and Smart Systems, 2005, pp. 89-90, doi: 10.1109/ICMENS.2005.31.
2. F. Brunetti, . Garay, J. C. Moreno and J. L. Pons, "Enhancing functional electrical stimulation for emerging rehabilitation robotics in the framework of hyper project," 2011 IEEE International Conference on Rehabilitation Robotics, 2011, pp. 1-6, doi: 10.1109/ICORR.2011.5975370.
3. K. W. E. Cheng, Yan Lu, Kai-Yu Tong, A. B. Rad, D. H. K. Chow and D. Sutanto, "Development of a circuit for functional electrical stimulation," in IEEE Transactions on Neural Systems and Rehabilitation Engineering, vol. 12, no. 1, pp. 43-47, March 2004, doi: 10.1109/TNSRE.2003.819936.
4. Blanger M, Stein RB, Wheeler GD, Gordon T, Leduc B. Electrical stimulation: can it increase muscle strength and reverse osteopenia in spinal cord injured individuals? Arch Phys Med Rehabil. 2000 Aug;81(8):1090-8. doi: 10.1053/apmr.2000.7170. PMID: 10943761.
5. Q. Xu, T. Huang, J. He, Y. Wang and H. Zhou, "A programmable multi-channel stimulator for array electrodes in transcutaneous electrical stimulation," The 2011 IEEE/ICME International Conference on Complex Medical Engineering, 2011, pp. 652-656, doi: 10.1109/ICCME.2011.5876821.

6. Roger M. Enoka, Ioannis G. Amiridis, and Jacques Duchateau, "Electrical Stimulation of Muscle: Electrophysiology and Rehabilitation", *Physiology*, vol. 35, no. 1, pp.40-56, 2020, doi: 10.1152/physiol.00015.2019.
7. Y. Hsueh and G. Chen, "Design of high voltage digital-to-analog converter for electrical stimulator," 2012 IEEE Asia Pacific Conference on Circuits and Systems, 2012, pp. 77-80, doi: 10.1109/APCCAS.2012.6418975.
8. B. Velloso and M. N. Souza, "A Programmable System of Functional Electrical Stimulation (FES)," 2007 29th Annual International Conference of the IEEE Engineering in Medicine and Biology Society, 2007, pp. 2234-2237, doi: 10.1109/IEMBS.2007.4352769.
9. Chen M, Wu B, Lou X, Zhao T, Li J, Xu Z, Hu X, Zheng X. A self-adaptive foot-drop corrector using functional electrical stimulation (FES) modulated by tibialis anterior electromyography (EMG) dataset. *Med Eng Phys.* 2013 Feb;35(2):195-204. doi: 10.1016/j.medengphy.2012.04.016. Epub 2012 May 22. PMID: 22621781.
10. S. Khosravani, N. Lahimgarzadeh and A. Maleki, "Developing a stimulator and an interface for FES-cycling rehabilitation system," 2011 18th Iranian Conference of Biomedical Engineering (ICBME), 2011, pp. 175-180, doi: 10.1109/ICBME.2011.6168550.
11. M. Yochum, S. Binczak, T. Bakir, S. Jacquir and R. Lepers, "A mixed FES/EMG system for real time analysis of muscular fatigue," 2010 Annual International Conference of the IEEE Engineering in Medicine and Biology, 2010, pp. 4882-4885, doi: 10.1109/IEMBS.2010.5627264.