

The solution space of metabolic networks: Producibility, robustness and fluctuations

Original

The solution space of metabolic networks: Producibility, robustness and fluctuations / De Martino, A.; Marinari, E.. - In: JOURNAL OF PHYSICS. CONFERENCE SERIES. - ISSN 1742-6588. - 233:(2010), p. 012019. [10.1088/1742-6596/233/1/012019]

Availability:

This version is available at: 11583/2976773 since: 2023-03-10T09:43:00Z

Publisher:

Institute of Physics Publishing

Published

DOI:10.1088/1742-6596/233/1/012019

Terms of use:

This article is made available under terms and conditions as specified in the corresponding bibliographic description in the repository

Publisher copyright

(Article begins on next page)

OPEN ACCESS

The solution space of metabolic networks: Producibility, robustness and fluctuations

To cite this article: A De Martino and E Marinari 2010 *J. Phys.: Conf. Ser.* **233** 012019

View the [article online](#) for updates and enhancements.

You may also like

- [Selective pressure on metabolic network structures as measured from the random blind-watchmaker network](#)
Sebastian Bernhardsson and Petter Minnhagen
- [Slave nodes and the controllability of metabolic networks](#)
Dong-Hee Kim and Adilson E Motter
- [Flux networks in metabolic graphs](#)
P B Warren, S M Duarte Queiros and J L Jones

Free the Science Week 2023 April 2–9

Accelerating discovery through
open access!



www.ecsdl.org

Discover more!

The solution space of metabolic networks: producibility, robustness and fluctuations

A. De Martino^{1,2} and E. Marinari²

¹CNR/IPCF, UoS Roma–Sapienza and ²Dipartimento di Fisica, Sapienza Università di Roma, p.le A. Moro 2, 00185 Roma, Italy

E-mail: andrea.demartino@roma1.infn.it, enzo.marinari@roma1.infn.it

Abstract. By flux analysis one generically indicates a class of constraint-based approaches to the study of biochemical reaction networks concerned with the calculation of the flux configurations compatible with given stoichiometric and thermodynamic constraints. One of its main areas of application is the study of cellular metabolic networks. We briefly and selectively review the main approaches to this problem and then, building on recent work, we provide a characterization of the productive capabilities of the metabolic network of the bacterium *E.coli* in a specified growth medium in terms of the producible biochemical species. While a robust and physiologically meaningful production profile clearly emerges, the underlying constraints still allow for significant fluctuations in the net production even for key metabolites like ATP and, as a consequence, apparently lay the ground for different growth scenarios.

1. Introduction

At a rough conceptual level, living cells can be seen as devices that convey the free energy derived from the breakdown of nutrients (mostly sugars) into the chemical energy that fuels the production of the molecules required for survival and, when possible, growth and reproduction. The complex intracellular machinery that underlies the energy transduction is being increasingly unveiled at both the biochemical (reactions) and the regulatory level (enzymes, their corresponding genes, the genes' transcription factors, etc) through the massive genomic information available for different organisms [1]. In particular, the network of biochemical processes collectively known as 'metabolism' by which the nutrients are degraded and the housekeeping molecules are manufactured has been mapped in great detail for many bacteria and several eukaryotes [2]. While the study of the structure and dynamics of single metabolic pathways has a long standing history in biophysical chemistry [3, 4], the current wealth of data allows to analyze the behavior of cellular reaction networks at the scale of the whole genome. This is a crucial step both to shed light on the emergence of a metabolic phenotype from the underlying genotype and to formulate testable [5] predictions on a cell's adaptation and response to perturbations (the key to multiple biotechnological applications).

Ultimately, metabolic activity and capabilities are determined (or limited) by various constraints of chemical (stoichiometric), thermodynamic and regulatory origin. The uncertainty about their details however increases considerably as one passes from the stoichiometric to the regulatory level. Current theoretical approaches therefore try to infer the global organization of metabolism from simple schemes that implement explicitly only the best known restrictions,

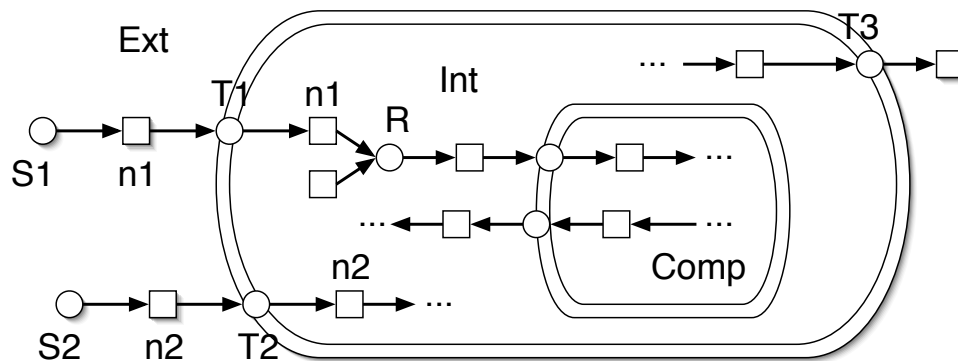

Figure 1. Basic scheme of a cellular metabolic network. Ext and Int denote respectively the exterior and the interior of the cell. Reactions (resp. metabolites) are denoted by circles (resp. squares). S1 and S2 are auxiliary fluxes supplying nutrients n1 and n2 to the environment. T1, T2 and T3 denote membrane transport reactions by which metabolites are taken in or expelled from the cell. R is an intracellular reaction. A cellular compartment Comp is also shown, together with the corresponding transport reactions connecting its interior with the cytosol.

making as few assumptions as possible on the rest. Even so, it turns out that some predictive and explanatory power on a cell's biochemical functioning can be achieved.

We begin by presenting a short selective review of stoichiometric models of metabolic networks as constraint-based systems. We then focus on one specific problem, that of metabolite producibility, characterizing the global metabolic output for the bacterium *E.coli* in a specified growth medium. While a robust and biologically significant production profile emerges, one still observes fluctuations in nutrient usage or in the output level of key metabolites that can be associated to variations in the overall flux of different metabolic pathways. This suggests that more metabolic phenotypes (with e.g. varying growth capabilities) might be compatible with the given environmental, thermodynamic and stoichiometric constraints. Finally we discuss some of the issues where statistical mechanics tools may have a significant impact in the near future. For the sake of simplicity we shall limit biochemical details to the necessary minimum and treat the reaction system as a standard input-output network. For metabolite abbreviations (as well as for stoichiometric data) regarding our case study, we shall follow the detailed genome-scale reconstruction of *E.coli*'s metabolic network described in [6]. The interested reader is referred to e.g. [3] for a thorough introduction to cellular metabolism.

2. Flux analysis: a bird's eye view

In essence (see Fig. 1), a cell's metabolic network can be seen as a set of interconnected chemical reactions coupled with a set of transport processes. For bacteria, this includes the membrane transport mechanisms by which nutrients are brought into the cell, and the intracellular reactions by which they are degraded and new biochemical species are produced. In organisms with compartmentalized cells (e.g. eukaryotes) one should also account for the transport of metabolites into and out of each compartment, i.e. for the cell's spatial structure. The basic and most reliable information on the, say, N reactions involving M chemical species is encoded in the $M \times N$ stoichiometric matrix Ξ , whose entry ξ_i^μ represents the stoichiometric

coefficient with which species μ participates in reaction i . Ξ is a sparse, integer matrix and a sign convention is usually adopted to discern products ($\xi_i^\mu > 0$) from substrates ($\xi_i^\mu < 0$). The stoichiometric matrix often also contains a motivated assumption on reaction directionality to account for the fact that, while all reactions are in principle reversible, under physiological conditions some of them may occur in one direction only. We shall treat physiologically reversible reactions as two separate processes. In addition, we shall always assume that Ξ also includes external supply fluxes for the nutrients, i.e. auxiliary (free or fixed) reactions that provide the nutrient to the environment. To have an idea, in such a setting $N \simeq 1100$ and $M \simeq 700$ for the bacterium *E.coli*, whereas $N \simeq 1500$ and $M \simeq 900$ for the unicellular eukaryote *S.cerevisiae*.

If we denote by $\nu \geq \mathbf{0}$ the N -dimensional vector of reaction fluxes (the sign constraint arising from our treatment of reversibility), the time evolution of the vector \mathbf{c} of metabolite concentrations is described simply by $\dot{\mathbf{c}} = \Xi\nu$. Fluxes depend in principle on the membrane transport mechanisms or on the enzyme kinetics through various parameters like the rate constants \mathbf{k} and \mathbf{c} itself and in turn, through them, on temperature, activation energy, etc. If such details are known, then functional dependencies $\nu = \nu(\mathbf{c}, \mathbf{k}, \dots)$ can be chosen according to the corresponding kinetics (e.g. Michaelis-Menten or Hill) and one can in principle solve the dynamical system for the concentrations, provided all underlying constants are known. Unfortunately, this is rarely the case in genome-scale networks (see [7] for a positive example). While methods have been developed to partially overcome this limitation and provide dynamical characterizations of metabolic activity (see e.g. [8, 9]), the standard modeling route assumes, on the basis of the timescale separation between chemical processes and genetic regulation, that metabolic networks operate in a non equilibrium steady state where $\dot{\mathbf{c}} = \mathbf{0}$. Note that flux vectors satisfying $\Xi\nu = \mathbf{0}$ describe states in which intracellular metabolites obey Kirchhoff-type mass-balance conditions. If $N > M$, as it usually occurs in real metabolic networks, such vectors form a set of dimension $N - \text{rank}(\Xi)$ embedded in \mathbb{R}_0^+ that, in absence of additional constraints, contains equivalent feasible flux states of the network. In principle, this set should be explored uniformly to extract the relevant biological information. Unfortunately, Monte Carlo sampling becomes unaffordable as soon as the dimension of the solution space exceeds a few tens (see [10] for a feasible case; message-passing algorithms have been recently proposed as a working alternative for microbial cells [11]). In many cases it is however possible to select relevant configurations by imposing the maximization of an objective function normally represented as a linear combination of the fluxes with given coefficients α , i.e. $\alpha \cdot \nu$. This reduces the problem to a linear optimization one, namely

$$\max_{\mathbf{0} \leq \nu \leq \nu_{max}} (\alpha \cdot \nu) \quad \text{subject to} \quad \Xi\nu = \mathbf{0} \quad (1)$$

The upper bounds on fluxes can be chosen to either model specific extracellular conditions (e.g. a certain nutrient's supply or intake cannot exceed a fixed level), to simulate known physiological limitations (e.g. the rate of a certain reaction cannot exceed a fixed level because of limited enzyme availability), or simply to impose well-defined bounds on the solution space. This scenario is the basis of various stoichiometry-based approaches such as Flux-Balance Analysis (FBA) [12]. Clearly, the vector α contains the crucial biological assumptions. In some cases, it is grounded in experimental evidence. For instance, bacteria in rich environments appear to evolve, under selective pressure, to optimize their growth rate and reproduce as fast as possible [13]. A good proxy for a bacterium's growth capability lies in its ability to generate *biomass*, a combination of different metabolites in precise stoichiometric proportions (including the 20 proteinogenic amino acids, the molecular energy carrier ATP, water, key cofactors like nicotinamide adenine dinucleotide [nad], nicotinamide adenine dinucleotide phosphate [nadp] and coenzyme-A [coa] etc.) that is used to produce ADP, inorganic phosphate (PI),

pyrophosphate (PPI) and water (h₂o) [14, 6]¹. In brief, this reaction represents the cell's use of metabolic products in macromolecular processes (like building proteins, membranes, etc.) that are not accounted for in Ξ . The maximization of biomass yield is in these cases a widely used criterion implemented by adding the auxiliary biomass reaction to Ξ . In other cases, the choice may have physiological justifications. The need for energetically-efficient housekeeping e.g. in nutrient-limited conditions suggests that cells optimize the ATP yield, which requires to maximize the total flux of all ATP-producing reactions [15]. Other examples include the minimization of glucose consumption (a proxy for efficient nutrient usage [16]) or of the total flux of intracellular reactions (for maximal enzymatic efficiency [17]). We refer the reader to [18] for a comparison of the performance of several different objective functions for predicting the fluxes of the main carbon pathways in *E.coli* and to [19] for a study of objective function selection criteria.

This kind of approach can be extended to biologically more complicated situations like those induced by gene knock-outs that prevent the execution of certain reactions. Based on experimental evidences, such scenarios lead to consider different selection criteria, like the minimization of the overall flux rearrangements with respect to the wild type (by quadratic programming [20]) or the minimization of rearrangements in the large-flux backbone with respect to the wild type (by mixed linear-integer programming [21]). The former appears to be suited to capture the transient sub-optimal growth states that a bacterium takes on immediately after the perturbation, whereas the latter provides a better description of the states of fast growth that the knock-out organism reaches on longer time scales under selective pressure. However the dynamical structure of the response of metabolic networks to perturbations is far from being satisfactorily understood.

3. Producibility and Von Neumann's problem

An important problem related to flux analysis concerns the link between the network's structure and its productive capabilities. Following [22], a metabolite μ is said to be *producibile* from a given set of nutrients (to be specified) if

$$\exists \nu \geq \mathbf{0} \text{ such that } \Xi\nu \geq \mathbf{0} \ \& \ [\Xi\nu]_{\mu} > 0 \quad (2)$$

(where $[\Xi\nu]_{\mu} = \sum_{i=1}^N \nu_i \xi_i^{\mu}$) that is, if at least one flux vector exists allowing for a net production of μ irrespective of whether other metabolites are being also produced (nutrient usage may evidently never exceed its supply). Producible metabolites have the property that their concentrations can increase in a stationary flux state with the sole consumption of the nutrients, so that the cell is allowed to employ them for purposes other than metabolic (e.g. to form proteins, membranes, etc.). One would therefore expect that an organism's behavior in a given environment is related to its ability to produce the metabolites necessary for survival, growth etc. (e.g. biomass, ATP or else).

It is easy to understand that the possibility to actually produce a metabolite may be limited by the emergence of conservation laws from the stoichiometry. To clarify, note that M -dimensional vectors $\mathbf{z} \geq \mathbf{0}$ satisfying $\mathbf{z}^T \Xi = \mathbf{0}$ (or, positive semidefinite vectors from the left null-space of

¹ The biomass reaction reported in [6] reads as follows: (0.05)5mthf + (5.0E-5) accoa + (0.488) ala-L + (0.0010) amp + (0.281) arg-L + (0.229) asn-L + (0.229)asp-L + (45.7318)atp + (1.29E-4)clpn-EC + (6.0E-6)coa + (0.126)ctp + (0.087)cys-L + (0.0247)datp + (0.0254)dctp + (0.0254)dgtp + (0.0247)dttp + (1.0E-5)fad + (0.25)gln-L + (0.25)glu-L + (0.582)gly + (0.154)glycogen + (0.203)gtp + (45.5608)h₂o + (0.09)his-L + (0.276)ile-L + (0.428)leu-L + (0.0084)lps-EC + (0.326)lys-L + (0.146)met-L + (0.00215)nad + (5.0E-5)nadh + (1.3E-4)nadp + (4.0E-4)nadph + (0.001935)pe-EC + (0.0276) peptido-EC + (4.64E-4)pg-EC + (0.176)phe-L + (0.21)pro-L + (5.2E-5)ps-EC + (0.035)ptrc + (0.205)ser-L + (0.0070)spmd + (3.0E-6)succoa + (0.241)thr-L + (0.054)trp-L + (0.131)tyr-L + (0.0030)udpg + (0.136)utp + (0.402)val-L \rightarrow (45.5608)adp + (45.56035)h + (45.5628)pi + (0.7302)ppi. See [6] for a detailed list of metabolite abbreviations.

the stoichiometric matrix) define linear combinations of metabolites such that the corresponding weighted sums of their concentrations are constant over time [24]. Such conserved moieties² are abundant in real metabolic networks [25]. Clearly, an accumulation of metabolites belonging to one such pool, and hence their producibility, is ruled out by simple stoichiometric reasons. The duality of producibility and conservation can be exploited to identify (by linear programming) the growth media allowing for the production of specified sets of metabolites such as the biomass or slight modifications of it [23]³.

In order to evaluate the robustness of the cellular production profile (if any) emerging in given nutrient conditions one should study the set

$$\mathcal{V} = \{\boldsymbol{\nu} \text{ such that } \boldsymbol{\Xi}\boldsymbol{\nu} \geq 0\} \quad (3)$$

(we shall henceforth assume that $\sum_i \nu_i = N$). Statistical sampling in this case turns out to be feasible, a possible route being suggested by work of J. Von Neumann. In order to present a rather simplified version of his model [27], let us re-define the stoichiometric matrix by separating the matrix \mathbf{B} of input coefficients from the matrix \mathbf{A} of output coefficients, so that $\mathbf{A} - \mathbf{B} = \boldsymbol{\Xi}$. It is simple to see [28] that, given a constant $\rho > 0$, a flux vector $\boldsymbol{\nu}$ such that $\mathbf{A}\boldsymbol{\nu} \geq \rho\mathbf{B}\boldsymbol{\nu}$ describes a network state in which every species is being produced at a rate at least equal to ρ . In a generic input-output system specified by matrices \mathbf{A} and \mathbf{B} , one can therefore ask what is the maximum value of ρ for which flux vectors satisfying

$$(\mathbf{A} - \rho\mathbf{B})\boldsymbol{\nu} \geq 0 \quad (4)$$

exist. This value (denoted here as ρ^*) represents the optimal productive performance allowed by the ways in which the available processes combine the metabolites. Depending on whether ρ^* is larger or smaller than 1, the system may have optimal states that are expanding or contracting. Correspondingly, the flux vector(s) satisfying the above set of constraints for $\rho = \rho^*$ are the optimal flux states of the system. When $N, M \rightarrow \infty$ and \mathbf{A} and \mathbf{B} are taken to have non-negative entries but are otherwise unstructured random matrices, one can dissect the phase structure of the problem in detail by statistical mechanics tools, specifically using the replica trick (in a fully connected network where each reaction consumes and produces a finite fraction of the possible metabolites [28]) or the cavity method (in a finitely connected network where reactions use a finite number of substrates to generate a finite number of products [29]). The general lesson is that a critical value n_c of the structural parameter $n = N/M$ separates contracting from expanding regimes, with enhanced dilution increasing (resp. decreasing) ρ^* in the expanding (resp. contracting) phase. Moreover, in such cases a single flux vector satisfies conditions (4) when $\rho = \rho^*$. In the biologically more sensible case in which \mathbf{A} and \mathbf{B} are real stoichiometric matrices, the situation is radically different. The mass balance conditions imposed by stoichiometry or, equivalently, the existence of conserved metabolic pools, imply $\rho^* = 1$ (and force a finite volume of solutions in a random model with realistically structured input and output matrices [30]), so that the optimal solution space of (4) indeed coincides with (3). By exploiting the presence of ρ it is however possible to define a straightforward iterative algorithm that samples \mathcal{V} uniformly. Its basic idea, see [29] for details, is to locate a solution of (4) for small ρ (easy) and track it as ρ is increased and the solution space shrinks, until $\rho^*(= 1)$ is reached. Different “initial solutions” at small ρ lead to different final solutions at ρ^* and an unbiased sampling of (3) can be achieved. This ultimately allows for a complete and extensive characterization of producible metabolites and of the corresponding flux states in real cellular networks in a given environment at a modest computational cost even for genome-scale systems.

² Strictly, moieties are molecular subgroups (including functional groups) that are conserved over time in reaction networks, like e.g. the adenylate moiety in the pool formed by ATP, ADP and AMP.

³ An interesting extension of producibility is *sustainability*, loosely defined (see [26]) as the property of being producible using producible metabolites as substrates besides nutrients.

4. Application to *E.coli*: production profiles and their fluctuations

The volume (3) generated by the stoichiometric matrix of the bacterium *E.coli* has been studied in [31], revealing that

- (a) the predicted ranges of variability of the fluxes in \mathcal{V} in specified extracellular conditions agree well with the (limited) experimental data available on the reaction rates inferred from ^{13}C -based experiments in a similar nutrient profile [5, 32];
- (b) dynamically stiff variables, i.e. reactions with smaller allowed ranges, tend to correspond, via the associated enzyme, to *E.coli*'s phenomenologically essential genes, i.e. genes that are both necessary for the organism's survival and highly conserved across different bacterial species [33].

These results suggest that at least in some conditions metabolic networks may operate close to their optimal productive capacity and that the "shape" of \mathcal{V} might contain useful information relating the metabolic phenotype to the underlying genotype. The natural question to ask now is whether a robust metabolite production profile emerges and how it correlates with the physiologically defined biomass (in suitable growth media). We therefore take a closer look at the set of produced metabolites for *E.coli* in a minimal growth medium, an environment with a tunable supply of a limited set of nutrients formed by inorganic phosphate (PI), molecular oxygen (O_2), sulfate (SO_4), carbon dioxide (CO_2), potassium ion (K^+), ammonia (NH_3) and a carbon source (glucose in this case) [34] that resembles closely the M9 medium widely used in the experimental literature [32]. This network consists of 1057 reactions involving 631 metabolites altogether (after pruning the trivial producibility constraints, see [31] for details).

For simplicity, we henceforth set $\lambda = \Xi\nu$ and label the flux vectors from \mathcal{V} as ν_α, ν_β , etc. assuming to have sampled S such configurations. We shall furthermore write $\lambda_\alpha = \Xi\nu_\alpha$.

The simplest way to check whether \mathcal{V} defines a set of consistently produced metabolites is by studying the empirical covariance matrix \mathbf{C} given by

$$C^{\mu\mu'} = \frac{1}{S} \sum_{\alpha=1}^S \lambda_\alpha^\mu \lambda_\alpha^{\mu'} \quad (5)$$

In the spirit of principal component analysis, \mathbf{C} 's eigenvalue spectrum contains much information on the collective properties of the system. In particular, it is possible to express the underlying "signals" $\{\lambda_\alpha\}$ as weighted sums of the eigenvectors of \mathbf{C} . The presence of a large, isolated eigenvalue r_{max} indicates that $\lambda_\alpha^\mu \simeq \sqrt{r_{max}} V_{max}^\mu \eta_\alpha$, where \mathbf{V}_{max} is the eigenvector corresponding to r_{max} and η_α is a unit-variance random variable. Hence r_{max} and its corresponding eigenvector may offer an effective, zero-order description of \mathcal{V} in terms of the emergent production profile. The eigenvalue distribution for *E.coli* is shown in Fig. 2⁴. One clearly sees a giant eigenvalue separated by a roughly continuous spectrum, well described by the Marcenko-Pastur law with a point mass at $r = 0$ [35]. In metabolic terms, r_{max} represents a "network mode", a production profile that is common (to a first approximation) to all $\nu \in \mathcal{V}$. The components of the eigenvector corresponding to the network mode (Fig. 2, bottom) point explicitly to some of the metabolites that are expected to form the core of the metabolic production. These turn out to include⁵

- biomass components (e.g. 5mthf, atp, fad, h2o, nad, nadh, nadp, nadph)
- products of the biomass reaction (adp, h, pi, ppi)
- end points of metabolic pathways (waste compounds like acetate [ac], co2 or lactate [lac])

⁴ To remedy the uncertainty about relative fluctuations when $\lambda^\mu \ll 1$, one can set a threshold ϵ below which λ^μ is "effectively" zero. For the present case, values of $\epsilon \leq 0.01$ have been found to provide the same qualitative picture.

⁵ See [6] for a list of metabolite abbreviations.

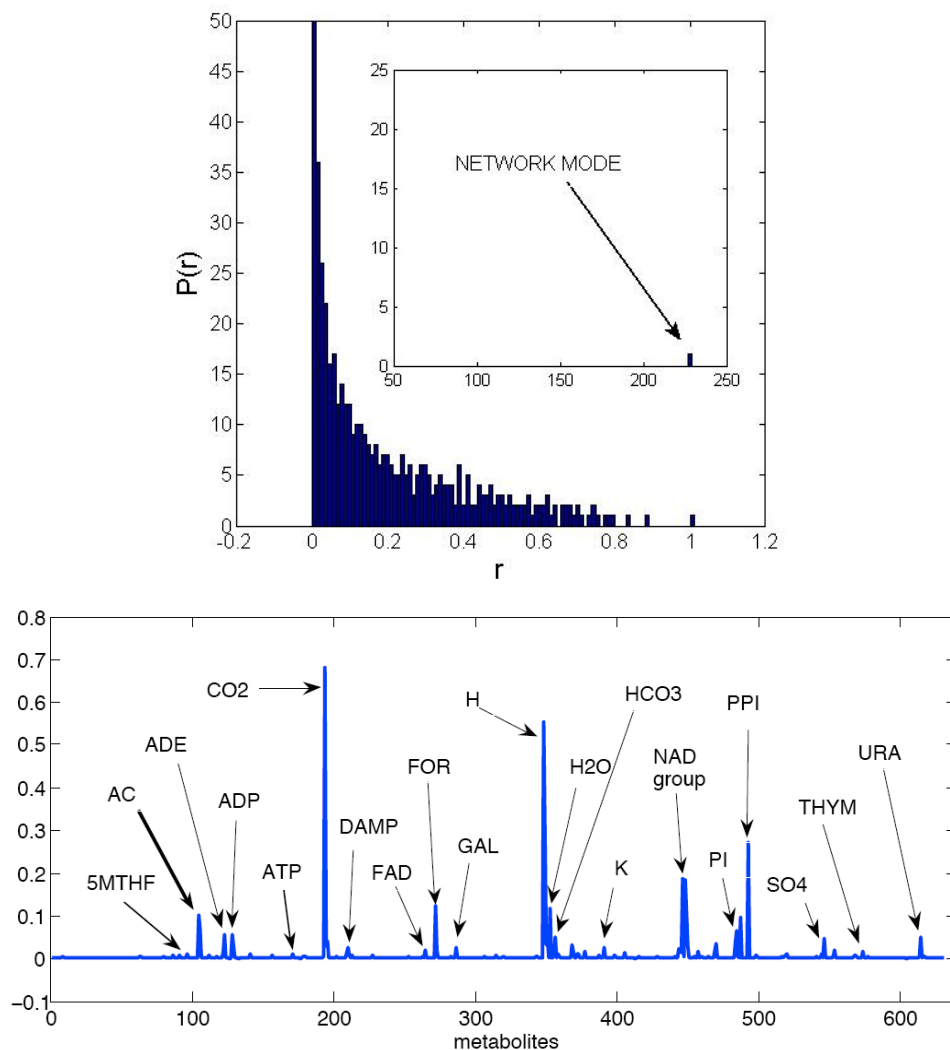

Figure 2. (Top) Histogram of the eigenvalues of the empirical correlation matrix \mathbf{C} , Eq. (5), for *E.coli* in a minimal growth medium (see text). Inset: detail of the “network mode”. (Bottom) Components of the eigenvector of \mathbf{C} corresponding to the network mode, with some of the producible metabolites explicitly indicated (see [6] for a list of metabolite abbreviations).

Such a profile is largely recovered by studying the average of λ^μ over 500 flux configurations $\nu \in \mathcal{V}$ for each μ , see Fig. 3. Focusing for clarity on the ones with the largest average producibility we find multiple biomass components (5mthf, amp, atp, coa, fad, h2o, leu-L, nad, nadh, nadp, nadph, ppi) and biomass products (adp, h, pi and ppi), supporting a growth scenario; typical waste products of metabolic activity (such as ac and co2, end point of oxidative phosphorylation); and metabolites with clear metabolic roles like formate [for] (central for h production), bicarbonate [hco3] and potassium ion [k] (helping to maintain a stable intracellular condition), succinate [succinate] (a key node of the Krebs cycle). In addition to these, a host of producible species appear, though with smaller λ^μ , including all amino acids (with the notable exception of leucine, which appears to has a large average net output).

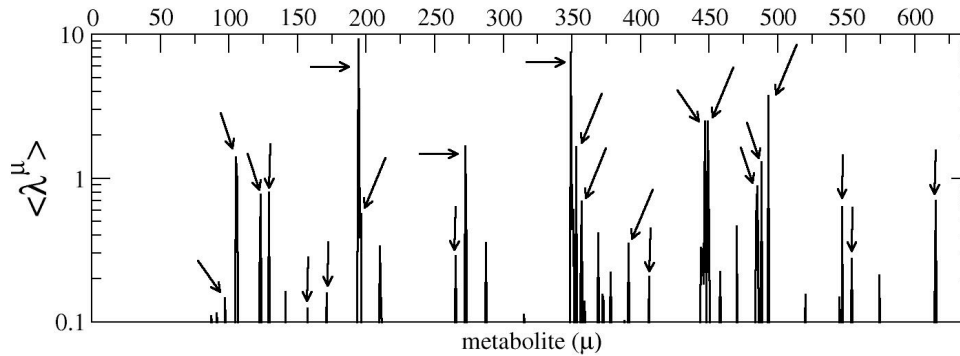

Figure 3. Value of λ^μ averaged over 500 flux states $\nu \in \mathcal{V}$ versus μ (metabolite, horizontal axis) for *E.coli* (631 metabolites) in a minimal growth medium (see text). Arrows mark, from left to right, the following metabolites (see [6] for a list of metabolite abbreviations): 5mthf, ac, ade, adp, amp, atp, co2, coa, fad, for, h, h2o, hco3, k, leu-L, the nad group (nad, nadh, nadp, nadph), nh4, pi, ppa, ppi, so4, succ and ura.

For most compounds, however, one finds $[\Xi\nu]_\mu = 0$ for each $\nu \in \mathcal{V}$. As said above, $[\Xi\nu]_\mu = 0$ if μ belongs to a conserved metabolic pool. Interestingly, such pools do not seem to exhaust the list of unproducible metabolites, as metabolite producibility turns out to be a significantly fluctuating property. To evaluate how the production profile of each metabolite varies across solutions in \mathcal{V} one can calculate, for each μ and for each pair of (distinct) flux vectors $\nu_\alpha, \nu_\beta \in \mathcal{V}$, the overlap

$$q_{\alpha\beta}^\mu = \frac{2\lambda_\alpha^\mu \lambda_\beta^\mu}{(\lambda_\alpha^\mu)^2 + (\lambda_\beta^\mu)^2} \quad (6)$$

When the above quantity is averaged over pairs $\alpha \neq \beta$ (properly accounting for the case where at least one $\lambda_\alpha^\mu \ll 1$), one obtains an index (we shall denote it by q^μ) that is closer to 1 the smaller are the fluctuations in λ^μ for metabolite μ . The distribution of q^μ is shown in Fig. 4. One sees that the production rate of many key metabolites including co2, atp, amp, the nad group, etc. may oscillate considerably from solution to solution in \mathcal{V} . This holds for intracellular species (e.g. ATP or biomass components) as well as for extracellular ones, so that even the amount of nutrients necessary for the cell to maintain its productive capability in an environment where a specific group of metabolites is present may have a large allowed range.

It is instructive to inspect two particular solutions out of those sampled from \mathcal{V} , namely those with the largest and smallest production of ATP. Denoting these respectively by ν_{max} and ν_{min} , in Fig. 5 we show, component by component, the quantities $\Delta\lambda = \lambda_{max} - \lambda_{min}$ and $\Delta\nu = \nu_{max} - \nu_{min}$. Analyzing the production profiles it turns out that the state with larger ATP production is closely associated to the network mode, i.e. it comes with a significant production of biomass components and of metabolic waste like ac and co2. On the contrary the state with reduced ATP production is associated to decreased co2 output and high lactate output. This is consistent with an increase of the flux through glycolysis, a central, anaerobic carbon pathway with limited ATP productive efficiency that leads to the generation of lactate. Large ATP output is instead achievable by strengthening aerobic pathways that employ oxidative phosphorylation (with higher ATP-production efficiency) with the concomitant production of co2. Note however that oxygen is available in the cell's environment, so it is reasonable to expect that aerobic solutions will dominate (as the the network mode also shows). The oxygen intake indeed does not fluctuate significantly across the solution space and co2 production, while not tightly constrained, appears to be consistently large. These different states are thus unlikely

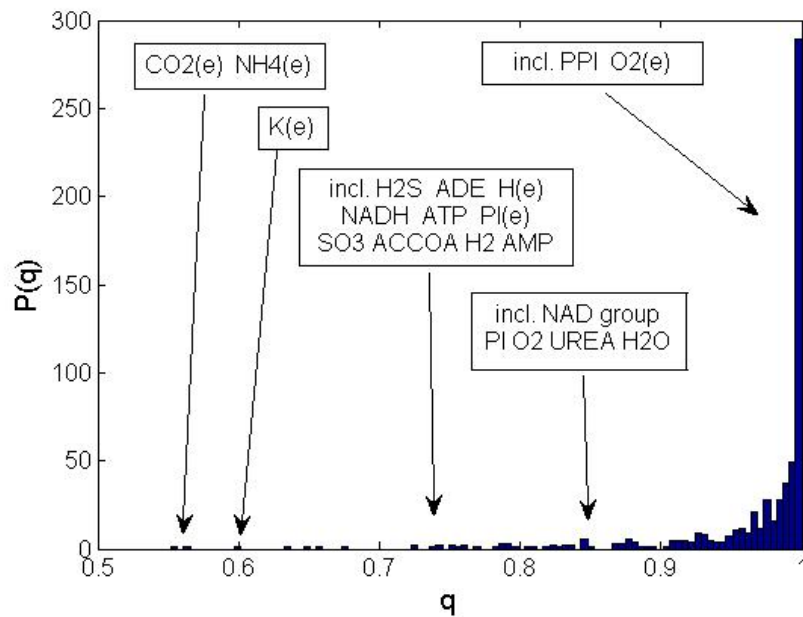

Figure 4. Distribution of $q^\mu = \langle q_{\alpha\beta}^\mu \rangle$ (average over pairs of distinct solutions from \mathcal{V}). The index e (extracellular) denotes metabolites that also serve as nutrients. Arrows mark groups of metabolites (as shown) falling in the corresponding range of q .

to represent genuinely different metabolic phenotypes operating in aerobic and, respectively, anaerobic modes, but more simply signal the existence of viable flux rearrangements (compatible with all specified constraints) with increased weight for anaerobic pathways relative to the more efficient aerobic ones. While a more careful analysis is needed to map the exact locations of the flux rearrangements, the overall difference in the organization of flux between the two states is indeed significant. From a biological perspective, these states may correspond to different growth properties, that could perhaps be identified by studying distribution of growth rates of bacterial colonies in a fixed environment. On the other hand, this shows that a sharper selection of production profiles, and thus a better identification of metabolic objectives, requires constraints that are still not included in the available theories.

5. Discussion

Metabolic networks control, directly or indirectly, many of the most basic tasks cells must accomplish, from the synthesis of amino acids, to the maintenance of osmotic balance with the exterior, to the response to environmental shifts. A possible key to improve our understanding of their organization lies in our opinion in the identification of the physical, stoichiometric, thermodynamic or regulatory factors that intrinsically limit their productive potential and determine the overall outcome of metabolic activity. Constraint-based approaches provide a simple mathematical frameworks where many of the emerging properties of metabolism can be analyzed quantitatively. We have shown here that while the constraints that are normally employed are sufficient to describe the main physiological aspects of a cell's growth performance in a certain medium, they may be still insufficient to infer precise metabolic objective functions by which one could capture, e.g., objective shifts under varying nutrient conditions. Otherwise it would be important to understand whether the observed fluctuations have biological counterparts. In addition to the problems presented here, the methods of

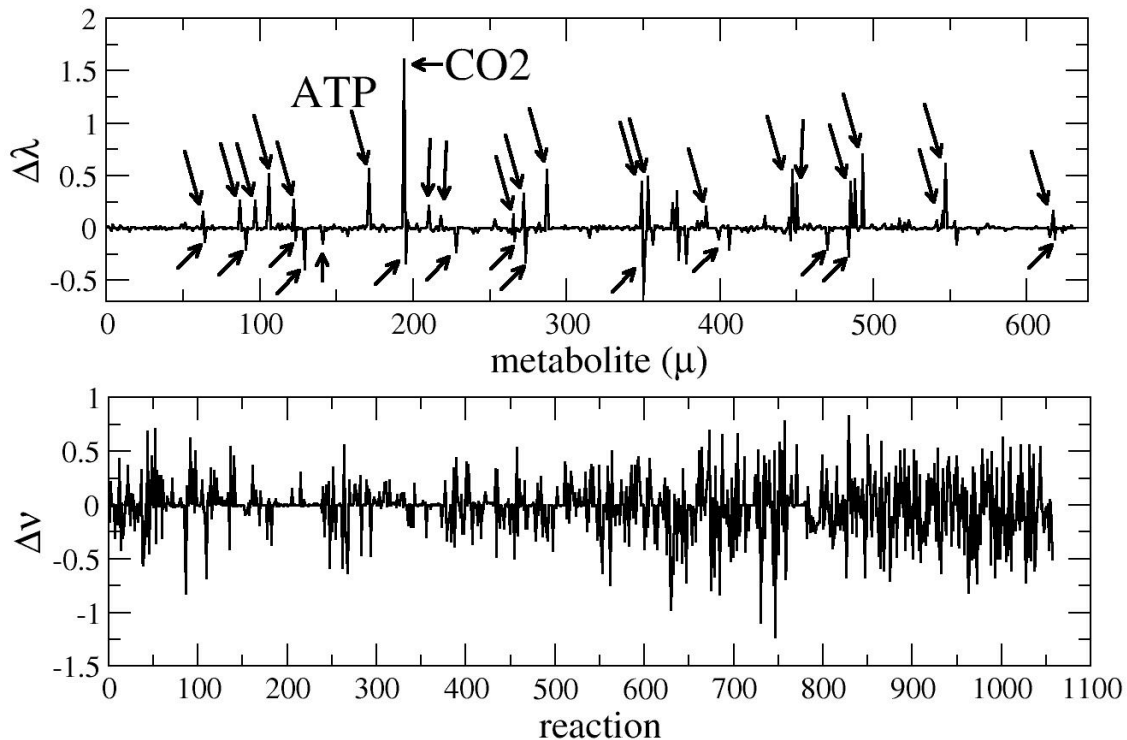

Figure 5. (Top) Component by component difference in λ and (Bottom) in ν between the solution with the largest and smaller production rate of ATP. The number of metabolites is 631, that of reactions 1057. Arrows in the top figure mark, from left to right, the following metabolites: in the positive half, 3mob, 5aizc, 5mthf, ac, ade, atp, co2, damp, dcyt, fad, for, gal, h, h2o, k(e), nad group, nh4, pi(e), ppi, so3, so4(e) and urea; in the negative half 3mop, 5caiz, ade(e), adp, akg, co2(e), dhf, fadh2, for(e), h(e), lac, pant-R, pi and urea(e).

statistical mechanics developed for the analysis of constraint-satisfaction problems may prove crucial to address many of the important questions arising in this field, both for the structural and the dynamical level [36].

Acknowledgments

This work was supported by the IIT Seed Project DREAM.

References

- [1] Liolios K *et al.* 2008 *Nucl. Acids Res.* **36** (Database issue) D475
- [2] Palsson B O 2006 *Systems Biology: Properties of Reconstructed Networks* (New York: Cambridge University Press)
- [3] Heinrich R and Schuster S 1996 *The regulation of cellular systems* (New York: Chapman & Hall)
- [4] Beard B A and Qian H 2008 *Chemical biophysics: Quantitative analysis of cellular systems* (Cambridge: Cambridge University Press)
- [5] Sauer U 2006 *Mol. Syst. Biol.* **2** 62
- [6] Reed J L *et al.* 2003 *Genome Biology* **4** R54
- [7] Jamshidi N *et al.* 2001 *Bioinformatics* **17** 286
- [8] Mahadevan R, Edwards J S and Doyle F J 2002 *Biophys J.* **83** 1331
- [9] Steuer R *et al.* 2006 *Proc. Natl. Acad. Sci. USA* **103** 11868
- [10] Wiback S J *et al.* 2004 *J. Theor. Biology* **228** 437
- [11] Braunstein A, Mulet R and Pagnani A 2008 *BMC Bioinformatics* **9** 240

- [12] Kauffman K, Prakash P and Edwards J S 2003 *Curr. Opin. Biotech.* **14** 491
- [13] Ibarra R U, Edwards J S and Palsson B O 2002 *Nature* **420** 186
- [14] Edwards J S and Palsson B O 2000 *Proc. Natl. Acad. Sci. USA* **97** 5528
- [15] Ramakrishna R *et al.* 2001 *Am J. Physiol. Regul. Integr. Comp. Physiol.* **280** R695
- [16] Oliveira A P, Nielsen J and Forster J 2005 *BMC Microbiol.* **5** 39
- [17] Holzhütter HG 2004 *Eur. J. Biochem.* **271** 2905
- [18] Schuetz R, Kuepfer L and Sauer U 2007 *Mol. Syst. Biol.* **3** 119
- [19] Knorr A L, Jain R and Srivastava R 2007 *Bioinformatics* **23** 351
- [20] Segre D, Vitkup D and Church G M 2002 *Proc. Natl. Acad. Sci. USA* **99** 15112
- [21] Shlomi T, Berkman O and Ruppin E 2005 *Proc. Natl. Acad. Sci. USA* **102** 7695
- [22] Imielinski M *et al.* 2005 *Bioinformatics* **21** 2008
- [23] Imielinski M *et al.* 2006 *Biophys. J.* **90** 2659
- [24] Famili I and Palsson BO 2003 *Biophys. J.* **85** 16
- [25] Nikolaev E V, Burgard A P and Maranas C D 2005 *Biophys. J.* **88** 37
- [26] Kruse K and Ebenhoeh O 2008 *Genome Inform.* **20** 91
- [27] Von Neumann J 1945 *Rev. Econ. Stud.* **13** 1
- [28] De Martino A and Marsili M 2005 *J. Stat. Mech.* L09003
- [29] De Martino A *et al.* 2007 *J. Stat. Mech.* P05012
- [30] De Martino A, Martelli C and Massucci F 2009 *Europhys. Lett.* **85** 38007
- [31] Martelli C *et al.* 2009 *Proc. Natl. Acad. Sci. USA* **106** 2607
- [32] Emmerling M *et al.* 2002 *J. Bacteriol* **184** 152
- [33] Gerdes S Y *et al.* 2003 *J. Bacteriol* **185** 5673
- [34] Almaas E *et al.* 2004 *Nature* **427** 839
- [35] Bouchaud J P and Potters M 2009 Financial Applications of Random Matrix Theory: a short review *Preprint* arXiv:0910.1205
- [36] De Martino A *et al.* 2009 Optimal flux states, reaction replaceability and response to knockouts in human red blood cell *Preprint* arXiv:0907.2824