

Analysis of Fuel Gasification Using Solar Technology: A Patent Review

Original

Analysis of Fuel Gasification Using Solar Technology: A Patent Review / Zhumagulov, Mikhail; Omirbayeva, Aizhan; Papurello, Davide. - In: GASES. - ISSN 2673-5628. - 6:1(2026). [10.3390/gases6010003]

Availability:

This version is available at: 11583/3006337 since: 2026-01-08T09:57:06Z

Publisher:

MDPI

Published

DOI:10.3390/gases6010003

Terms of use:

This article is made available under terms and conditions as specified in the corresponding bibliographic description in the repository

Publisher copyright

(Article begins on next page)

Review

Analysis of Fuel Gasification Using Solar Technology: A Patent Review

Mikhail Zhumagulov ¹, Aizhan Omirbayeva ^{1,*} and Davide Papurello ²

¹ Thermal Power Engineering Department, L.N. Gumilyov Eurasian National University, 010000 Astana, Kazakhstan; zhumagulov_mg@enu.kz

² Energy Center, Politecnico di Torino, Via Borsellino 38/18, 10095 Turin, Italy; davide.papurello@polito.it

* Correspondence: a.omerbaeva@mail.ru

Abstract

Solar energy enhances the energy and environmental performance of coal gasification by lowering carbon emissions and increasing the yield and quality of synthesis gas. This patent review surveys recent global advances in solar thermochemical reactors for coal gasification, focusing on key innovations disclosed in patent applications and grants, with particular attention to technologies that improve process efficiency and sustainability. The novelty of the review is that unlike most patent reviews that focus primarily on statistical indicators such as application counts, geography, and classification, this work integrates qualitative analysis of specific technical solutions alongside statistical evaluation. This combined approach enables a deeper assessment of technological maturity and practical applicability. Fifteen patents from different countries were reviewed. The largest number (8, 53%) belongs to the United States. China has the second place with 4 (27%). The remaining countries (the EU, Korea, and Russia) hold 1 patent (7% each). The present work emphasises the technological and engineering solutions associated with the integration of solar energy into gasification processes. The author's design is free of the disadvantages of its counterparts and is a simplified design with a high degree of adaptability to various types of fuel, including brown coal, biomass, and other carbon-containing materials.

Keywords: gasification; solar energy; coal technology; atmospheric radiation; fossil fuels; solar concentrators; pyrolysis; gasifier; thermochemistry

1. Introduction

Coal gasification is a thermochemical process that converts coal into synthesis gas (a mixture composed of H₂ and CO), widely used in different combustion devices [1] and electrical power generation by gas turbine [2] and the chemical industry and other sectors. Conventional gasification technologies [3], however, are inherently associated with elevated emissions of carbon dioxide and other pollutants. This is primarily due to their autothermal nature, whereby the heat required to sustain endothermic reactions is generated through the partial combustion of either the feedstock itself or a fraction of the produced synthesis gas. In the context of global energy transition and environmental imperatives, the development of innovative approaches that enhance both the efficiency and ecological sustainability of coal gasification has become a critical objective within the framework of sustainable development.

A promising direction in this regard is the integration of renewable energy sources, particularly concentrated solar energy, into coal and biomass gasification systems. Given the



Academic Editor: João
Fernando Pereira Gomes

Received: 1 December 2025

Revised: 29 December 2025

Accepted: 4 January 2026

Published: 7 January 2026

Copyright: © 2026 by the authors.

Licensee MDPI, Basel, Switzerland.

This article is an open access article distributed under the terms and conditions of the [Creative Commons Attribution \(CC BY\)](https://creativecommons.org/licenses/by/4.0/) license.

dynamic development of solar technologies in recent years, this may be a more competitive solution. Solar input can be harnessed to provide the high temperatures necessary for the process, thereby reducing reliance on fossil-derived heat and mitigating the associated carbon footprint. Depending on the technological configuration, solar energy may be utilised in various forms: for steam generation, for direct coal heating through concentrated radiation, or for supplying electricity via photovoltaic systems to meet the energy demands of auxiliary operations, for instance H₂ production by water electrolysis, an excess of which is necessary in, for example, FT synthesis. These approaches collectively illustrate the potential of solar-assisted gasification to advance the efficiency, environmental compatibility, and long-term viability of thermochemical fuel conversion.

Patent analysis is a fundamental instrument for assessing the state of innovation in any industrial sector, including the integration of solar energy into gasification processes. Patents registered in this domain not only document the historical trajectory of technological development but also highlight current trends and indicate prospects for future scientific and technological advances. They provide insight into key directions for improving existing technologies and serve as a basis for evaluating both the technological maturity and the commercial potential of emerging solutions.

Existing patent reviews of gasifiers contain only quantitative analysis. A qualitative analysis of the technologies used is not considered. Any review of patent developments for solar-powered gasifiers is absent. This paper is the first to fill this research gap.

The objective of this study is to perform a systematic analysis of patent documents related to the application of solar energy in the gasification of organic feedstocks and to outline a design framework suitable for the utilisation of Kazakhstani coals. The review encompasses a broad spectrum of technological approaches, including solar thermal collectors, photovoltaic systems, and hybrid configurations. In addition, the study identifies the principal scientific and technical challenges associated with these technologies and delineates promising avenues for further research and development in the field.

The patent analysis was conducted using open national and international platforms. There were no geographic restrictions on the review of inventions. Patent developments using solar energy as a heat source for the organic fuels gasification are few. For this reason, we did not set time limits and reviewed all existing publications.

The reviews of concentrated solar energy utilisation systems consider different applications of solar power, including coal and biofuel gasification as an idea [4]. A partial review of technologies applicable to biomass versus fossil fuels is available. The global environmental agenda includes reducing carbon dioxide emissions (from direct combustion) and achieving carbon neutrality in the future. Taking this fact into account, using solar energy as a heat source to replace fossil fuel combustion is becoming increasingly important. The efficient utilization of solar energy has become a major requirement to build a clean and efficient energy system and achieve the goal of carbon neutrality [5].

2. Materials and Methods

The patent analysis was conducted using open internet resources from various countries, moving from the specific to the general: 1. Kazakhstan Patent Database (<https://qazpatent.kz/en/> accessed on 1 September 2025); 2. CIS Countries (<https://yandex.ru/patents/> accessed on 1 September 2025); 3. Worldwide Database (Espacenet, WIPO, Google Patents, etc.). The search was conducted using the following keywords and inclusion criteria: solar gasification, solar concentrators for gasification, solar coal gasification, solar fuel gasification, solar-driven coal gasification, etc. The patent selection process was based on the PRISMA-type schematic for reviews.

Evaluation metrics for the analysis include novelty, applicability to Kazakhstan coals, simultaneous use of solar concentrating technology and fossil fuel gasification, technological readiness, geography and sustainability development impact.

Patent data analysis allows us to identify the key engineering approaches used to enhance the thermochemical conversion of carbon-containing materials, as well as to determine the most effective design solutions for reactors, heat-exchange systems, and solar concentrators. As a reference point, patent developments in gasification processes without the integration of solar energy sources were examined and taken as a baseline analogue [6]. The source [6] contains a distribution of patent activity by country. This methodological approach provides primarily a quantitative, supplemented by a partial qualitative assessment of the level of inventive activity and technological advancement in the field under consideration.

The methodology for analysing inventive activity was applied to solar-based technologies, followed by a more detailed qualitative analysis of the technologies.

Based on the results of quantitative analysis, key patents were identified that are of high technological significance and have potential applicability in the current conditions of Kazakhstan and other countries with significant reserves of solid organic fuels. The distribution of existing patents on the subject under study is presented in Table 1 and discussed in detail below.

Table 1. Results of the patent search on gasification using solar energy.

Patents on Coal Gasification Using Solar Energy	Date	Quantity of Patents
U.S. patents	23 November 1976–30 September 2010	8
European Patents	14 November 2001	1
Patents of Korea	3 March 2020	1
Patents of China	9 December 2009–27 February 2013	4
Patents of Russia	27 May 2006	1

3. Patent Review of Fuel Gasification Using Solar Technology

3.1. Review of U.S. Patents

The United States accounts for the largest number of patented developments. The earliest documented attempts to apply solar energy to gasification processes also originated in the U.S.

The patent by Antal [7] (1976) is recognised as basic and among the earliest patented solar gasification technologies. This patent discloses a method for producing synthesis gas from solid organic waste by employing concentrated solar radiation as the sole heat source. The process combines pyrolysis and gasification of organic feedstocks with subsequent catalytic conversion, enabling the transformation of waste materials into energy-rich gases such as hydrogen (H₂), carbon monoxide (CO), and methane (CH₄). The significance of this invention lies both in its demonstration of concentrated solar energy as a driver of chemical transformations and in its potential application to waste management.

The installation described in Patent [7] and schematized in Figure 1 comprises a solar furnace at the top of the tower, which uses a field of heliostats to focus direct solar radiation on a fixed focal point located at the base of a vertically oriented fluidised bed gasifier reactor. Solar energy enters the reactor through perforated quartz windows, where it is absorbed by the surface of solid fuel particles, effectively converting radiant energy into localised heat in the reaction zone. The process begins with the introduction of pre-ground solid organic matter into the reactor through a hopper with an air lock. The waste is impregnated with a catalyst, such as cobalt molybdate or sodium bicarbonate (NaHCO₃), which is

applied to the surface of the raw material by means of water impregnation and subsequent drying. Under the influence of a solar-heated environment (usually 600–700 °C), the organic fraction undergoes endothermic pyrolysis, resulting in the formation of volatile gases (CO, CO₂, CH₄, H₂) and a carbon-containing residue. At the same time, the fuel undergoes catalytic gasification through reactions with a preheated working medium (steam, CO₂ or a combination thereof), which is introduced under pressure through the base of the reactor in a countercurrent to maintain fluidisation and improve mass and heat transfer.

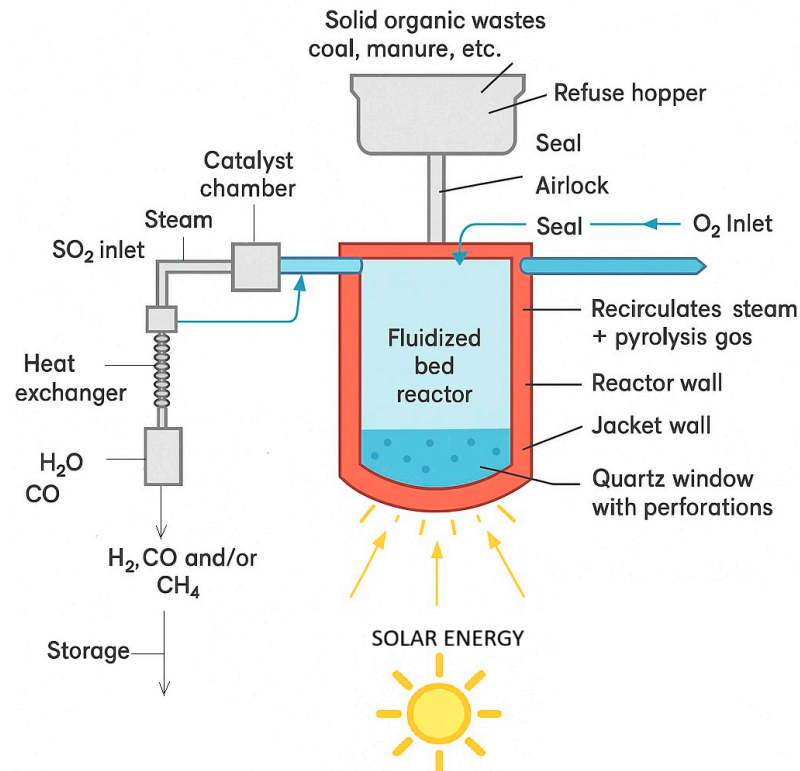

Figure 1. Schematic diagram of Antal's plant.

Technology limitation: Implementation of the technology requires the use of expensive catalysts; for maximum efficiency, inorganic impurities must be removed, which increases the cost of raw material preparation. The fluidised bed is essential for the operation of the described plant, but it is unstable and requires additional attention to maintain. The original design [7] considered only a fluidised-bed gasifier. Subsequently, Gregg [8] expanded the concept to incorporate moving-bed gasifiers and introduced an additional mirror positioned at the top of the tower, which are schematized in Figure 2. This mirror was designed to receive concentrated solar radiation reflected by ground-based heliostats, re-concentrate it, and redirect it toward the quartz window of the gasifier. In addition, the system provided heat recovery from the secondary mirror for steam generation [9]. One of the evident drawbacks of early designs was the rapid dust deposition on the quartz window during coal use, which obstructed solar radiation from entering the reactor bed. To address this, Frosch and Qader [10] proposed the introduction of a refractory honeycomb shell separating the solar window from the gasifier. This shell simultaneously functioned as a preheater for the gasification medium, composed of steam mixed with a portion of the generator gas. Their system also incorporated recovery and recirculation of the spent alkali metal catalyst, along with a backup reactor to maintain heat supply to the fluidised bed under conditions of insufficient solar input. In subsequent work, Aiman and Gregg (1983) [8] eliminated the use of catalysts by developing a three-zone gasifier—comprising a coal zone, a pyrolysis zone, and a gasification zone—operating at 900–1100 K

and 40 atm. Unlike the previous patent [8], coal is considered a raw material. The invention describes a gasification technology based on hydrocarbon conversion under the influence of solar energy, a significant part of which is converted into the chemical energy of new gas compounds.

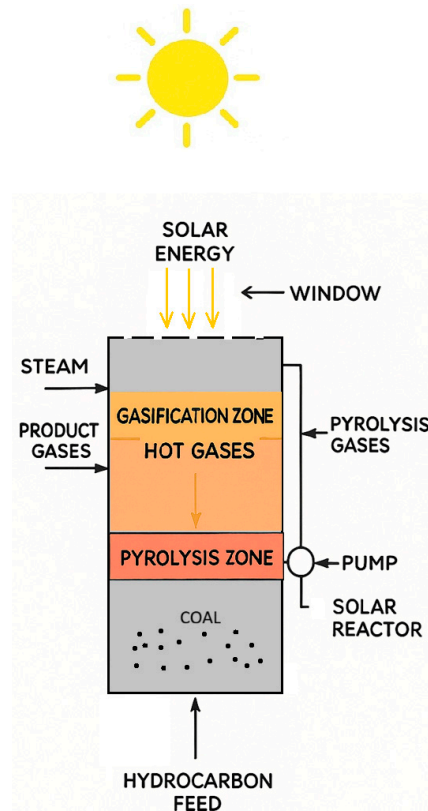

Figure 2. Schematic representation of a solar gasifier reactor.

Coal (or biomass) is converted into a gaseous product. Coal is fed into a solar reactor, and solar energy is directed into the reactor onto the charred coal, creating a gasification front and a pyrolysis front. The gasification zone is formed significantly above the coal level in the reactor. The pyrolysis zone is formed directly above the coal level. Water vapour fed into the reactor adjacent to the gasification zone reacts with coal to form a gaseous product that is burned. Solar energy provides the energy for the endothermic steam-coal reaction. Hot gaseous products flow from the gasification zone to the pyrolysis zone to heat the coal. The gases are removed from the pyrolysis zone and reintroduced into the reactor zone adjacent to the gasification zone. In this process, hydrocarbons are removed from the gas by converting steam into hot coal. The gaseous product is removed from the reactor area between the gasification zone and the pyrolysis zone [8].

Technology limitation: the system requires complex equipment to focus solar energy in two separate areas and maintain circulation of the pseudo-liquefied layer by redirecting the gas flow from the gasification zone to pyrolysis using a forced draft fan, which consumes additional electricity.

The invention described in Douglas Y. Jakahi [11] is based on the principles outlined in the Antal patent [7], developing and improving upon its approach. However, unlike the patent [7], where the main gasification medium was gas (steam, CO₂), the invention [11] uses molten salt, which increases heat transfer efficiency and catalyses the process. Technology reduces equipment costs and allows the reactor to be placed at ground level, eliminating the need for expensive support structures.

The supply of concentrated solar radiation keeps the medium in a molten state and achieves temperatures at which the carbon material reacts with steam to form a gaseous product. Additionally, the gasification medium may include alloying additives that improve solar radiation absorption [11]. The reactor design includes a chamber with a molten gasification medium and is equipped with a transparent window at the top through which solar radiation is directed downward from a horizontal reflector. A special partition system forms two chambers: an upper chamber containing the window and a lower chamber partially immersed in the gasification medium, with an opening for the synthesis gas to exit. This configuration prevents the window from meeting the aggressive medium and ensures process stability.

Figure 3 shows a general diagram of the installation, including the reactor with the molten gasification medium, the horizontal reflector, and the solar radiation delivery system. Figure 4 details the reactor design, in particular, the partition system that protects the transparent window from contact with the aggressive medium.

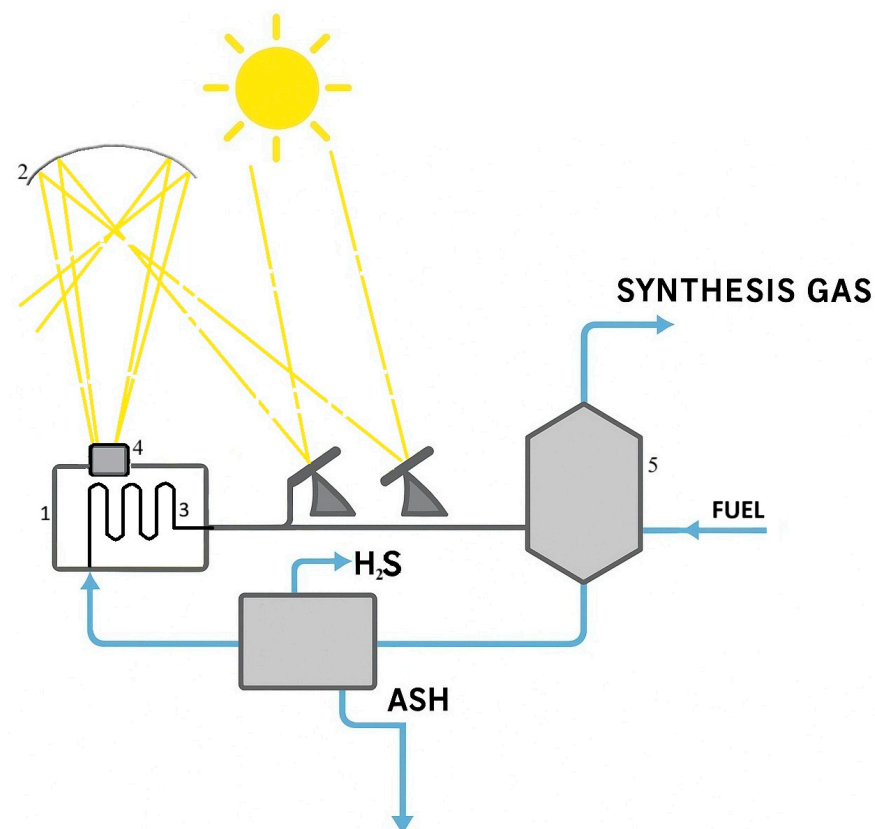

Figure 3. Diagram with a central solar radiation receiver at ground level: 1—central receiver, 2—reflector, 3—tubes, 4—window, 5—gasification reactor vessel.

In Figure 3 the reflector 2 directs concentrated solar radiation into the central receiver 1. The radiation passes through a transparent window 4 at the top of the receiver and impinges on the tubes 3 located within it. Window 4 serves to minimise heat loss from the receiver, while the tubes are heated to high temperatures by the incident solar flux. Molten salt circulating through these tubes is thereby heated and subsequently transported via pipelines to the gasification reactor vessel 5, where the stored solar heat is transferred to the gasification process.

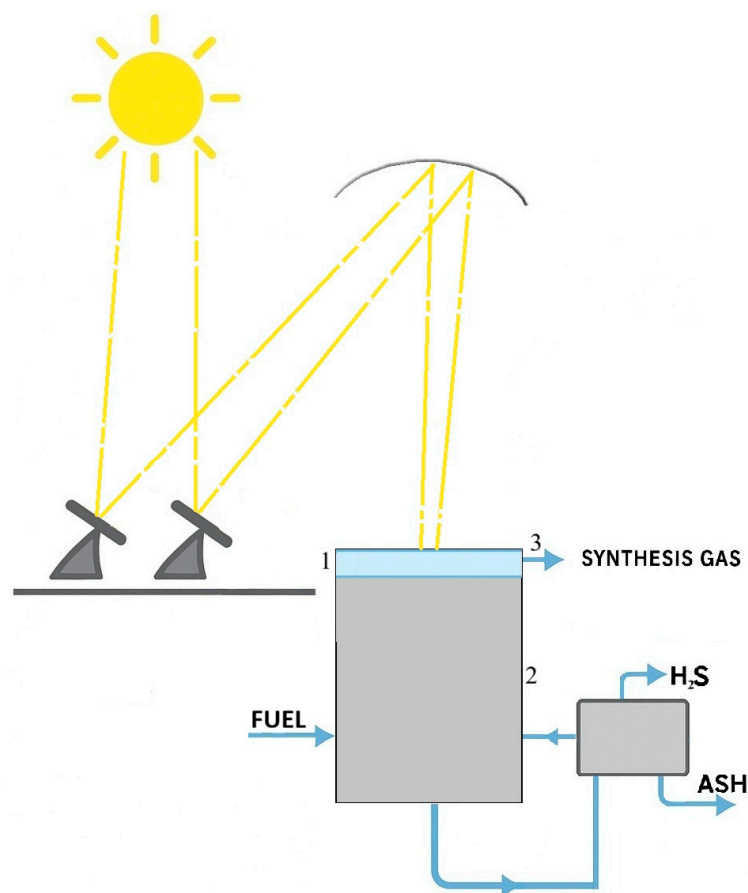

Figure 4. Diagram with a combined heating and gasification vessel: 1—window, 2—vessel, 3—upper section.

In the configuration illustrated in Figure 4, molten salt is heated by solar radiation transmitted through the transparent window 1 and absorbed directly within the combined heating and gasification vessel 2. The upper section 3 of vessel 2 is designed as a ring-shaped dome containing an outlet pipe for the collection and discharge of synthesis gas. The molten salt level in vessel 2 is regulated to prevent contact with the transparent window 1, thereby avoiding its exposure to the high-temperature and potentially corrosive molten medium. These design characteristics eliminate the need for auxiliary components such as additional pipes, pumps, and valves.

Technology limitation: although molten salts have high heat capacity, their thermal conductivity can be a limiting factor for rapid and uniform heating of the entire reaction medium; molten salts and carbon-containing materials can cause intense corrosion of reactor walls and pipelines; transparent windows can become contaminated or cloudy due to reaction product deposits, especially in the case of coal, which reduces the efficiency of solar radiation transfer; molten salts require special storage and transportation conditions, as they can crystallize when the temperature drops, leading to pipeline blockages.

Patent [12] describes a system in which an aqueous dispersion of carbonaceous material is introduced into a reactor in such a way that water droplets surrounding the carbonaceous material particles are formed. These droplets pass through a high-temperature focal zone created by concentrated solar radiation. When the particles cross this zone, rapid heating causes gasification reactions, converting the carbonaceous material into synthesis gas.

The installation described in Patent [12] and schematized in Figure 5 comprises a vertically oriented tubular solar reactor (1) with upper and lower sections (2, 3) fabricated

from a transparent, heat-resistant material such as quartz. The reactor is designed to receive concentrated solar radiation, focused by an external solar concentrator system into an internal high-temperature focal zone (4). An aqueous suspension of finely ground carbonaceous feedstock is introduced from a constant-pressure reservoir (10) via a spray head equipped with precision nozzles (5), producing a downward spray or droplet stream that traverses the focal zone. The reactor includes an upper gas outlet (6) for continuous removal of synthesis gas and a lower Section (3) equipped with a gas injection port (7) allowing the introduction of a countercurrent flow of steam, CO₂, or recycled synthesis gas to control the residence time of the reacting particles. Unreacted solid particles are collected at the bottom and recirculated through a loop (8), including a pump (9) and a check valve. This invention presents a two-phase (liquid-solid) reaction system, directly irradiated by concentrated solar flux—unlike previous approaches that relied on indirect heating or fixed solid beds. The use of water droplets enables rapid heat transfer to the embedded carbon particles while minimising the thermal load on the liquid volume.

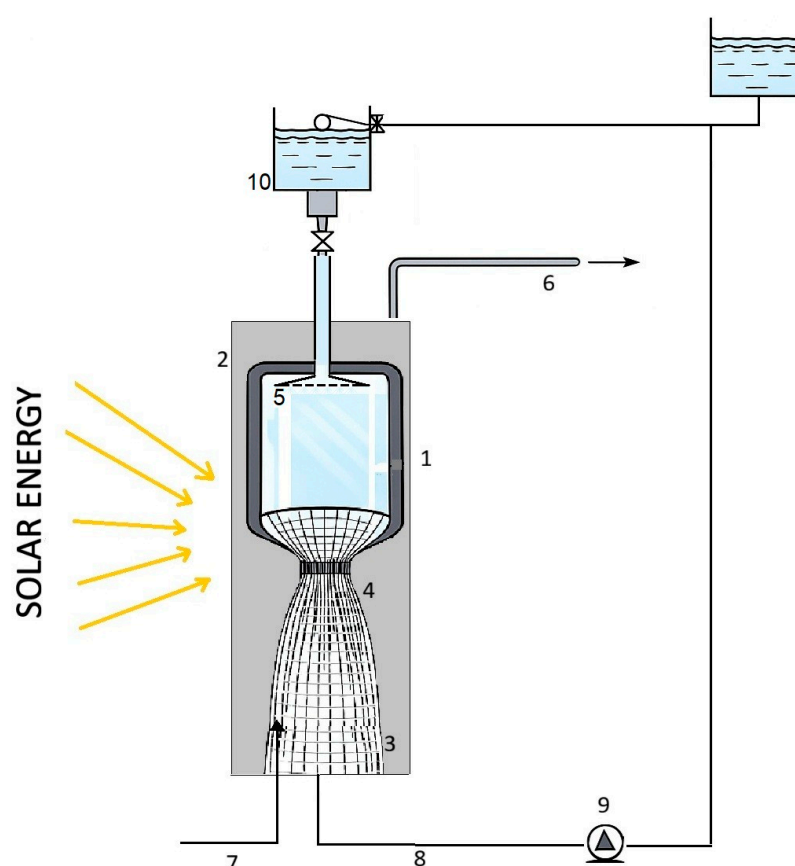

Figure 5. Diagram of a reactor installation with a high solar energy concentration system: 1—solar reactor, 2—upper sections, 3—lower sections, 4—internal high-temperature focal zone, 5—precision nozzles, 6—gas outlet, 7—gas injection port, 8—loop, 9—pump, 10—reservoir.

Technology limitation: The use of water-coal suspensions (WCS) adds to complexity and operating costs. Furthermore, there are difficulties in spraying WCS through nozzles designed for fuel oil. High temperatures impose severe limitations on the transparent window, which must withstand thermal stress and intense flow without deteriorating in performance.

The installation described in Patent [13] was schematized in Figure 6. Biomass is pyrolysed and/or gasified in a solar thermal reactor system at elevated temperatures. The system is based on a multi-tube solar reactor consisting of an outer shell and one

or more inner reaction tubes (shells). These inner shells are either directly or indirectly exposed to solar flux–focused sunlight delivered through a solar concentrator system (e.g., a heliostat field).

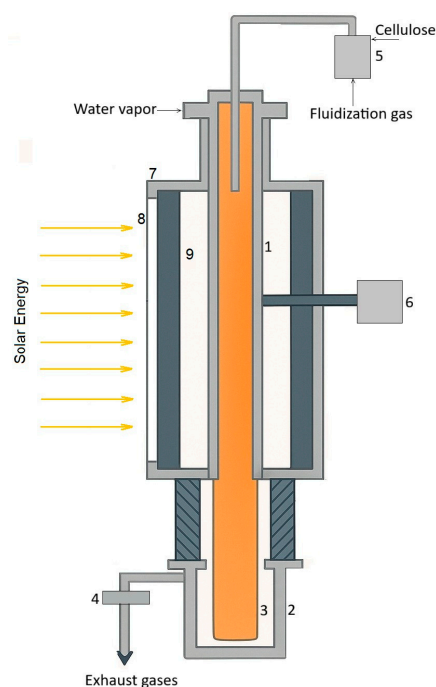

Figure 6. Single reactor vessel configuration: 1—Aluminium oxide reaction, 2—Particle collection container, 3—Gravity particle collector, 4—HEPA filter, 5—Fluidised bed feed system, 6—Pyrometer, 7—Outer protective shell, 8—Solar radiation opening in the protective shell, 9—Graphite heating element.

In a direct heating configuration, solar radiation passes through a transparent window and falls directly onto biomass particles carried by a carrier gas inside the reaction tube. The biomass is fed into the reactor in the form of finely dispersed particles (usually $<200\ \mu\text{m}$) carried by an inert or reactive gas such as steam or CO_2 . When heated by the sun to temperatures ranging from $950\ ^\circ\text{C}$ to $1400\ ^\circ\text{C}$, the biomass undergoes rapid pyrolysis or gasification with a residence time of less than 5 s and a heating rate exceeding $1000\ ^\circ\text{C}/\text{s}$. These rapid conditions prevent the formation of condensable resin species and promote high selectivity for synthesis gas production. The resulting gas stream can be further processed by water gas conversion or Fischer-Tropsch synthesis for the catalytic production of hydrogen or liquid fuel, as proposed in patent [14] based on the high-temperature multi-tube solar reactor shown in Figure 7.

The system is based on a solar receiver mounted on a tower and equipped with several entrained flow reaction tubes. A heliostat field focuses sunlight onto an aperture in the receiver, achieving a flux density > 1000 times the concentration. Inside the reactor, biomass gasification and optional steam methane reforming (SMR) take place, resulting in pure synthesis gas with an optimised $\text{H}_2:\text{CO}$ ratio (2.1–2.8:1).

Technology limitation: Reactor components, in particular transparent windows, are at risk of contamination from resin condensate, especially when coal is used as a raw material.

In another U.S. patent [10], solar radiation is introduced into a refractory honeycomb (original) shell that surrounds a fluidised bed reactor. Solar energy is focused on the honeycomb structure, which stores and distributes thermal energy. The system also has preheating paths for steam and recycled product gas, a catalyst regeneration unit, and a backup furnace for non-solar operation. This integrated design provides highly efficient

continuous gasification with reduced raw material and energy consumption compared to conventional methods.

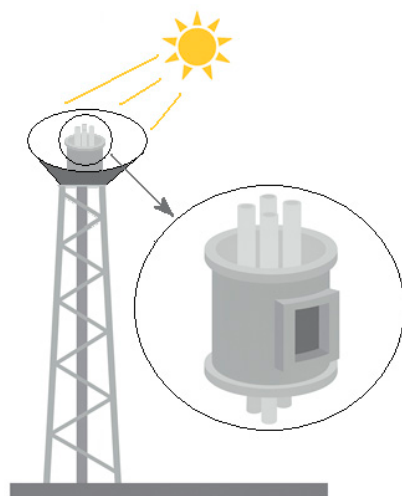

Figure 7. Diagram of a solar tower with receivers and solar concentrating fields with a multi-tube gas generator reactor.

The installation described in Patent [10] and schematized in Figure 8 includes a reactor (1), a reaction zone (2) surrounded by a refractory honeycomb shell (3), and an insulating casing with a solar window (4) through which solar radiation from a concentrator (5) enters the honeycomb structure. Carbonaceous feedstock (coal or biomass) is fed into the reactor (arrow 6), and steam and fluidising gas are preheated as they pass through the honeycomb shell, after which they enter the reaction zone for gasification. The synthesis gas and ash are discharged through a pipe (7), the ash is captured in a cyclone (8), and the gas is purified in a scrubber (9). Part of the gas is recirculated (10) back for use as fluidising gas. A backup furnace (11) is provided for start-up and operation in the absence of sunlight. The high-heat-capacity refractory honeycomb shell is a new solar heat absorption zone, by means of which the present invention heats the fluidising gas and steam to the desired temperatures for gasification. Water is initially introduced into steam generator (12), where steam is formed. The steam passes through pipeline (13) into the refractory honeycomb shell. The refractory honeycomb shell is maintained at the desired temperature (up to 1093 °C) by introducing high-intensity solar radiation from the solar concentrator (5) through the solar window (4) into the high-heat-capacity refractory honeycomb shell.

Technology limitation: There is no description of the heat energy source for steam generation. Due to the direct contact between the solid fuel flow and the honeycomb shell, it is likely to become dusty and accumulate condensate of ash-oil components, which will lead to a deterioration in the throughput capacity of the glass window (4).

Unlike previous inventions, patent [15] uses a series of heliostats to direct sunlight onto a secondary mirror mounted on a tower, which redirects the radiation through a quartz window into a gasification reactor. The installation described in Patent [15] was schematized in Figure 9. The reactor has a vertically or horizontally moving layer (compacted or fluidised) of coal, where steam reacts with heated coal to produce combustible gases. A new aspect is the integration of a steam generator at the rear of the secondary mirror, which uses absorbed solar energy to generate process steam, thereby increasing efficiency. The design minimises window contamination by solid particles and optimises heat distribution.

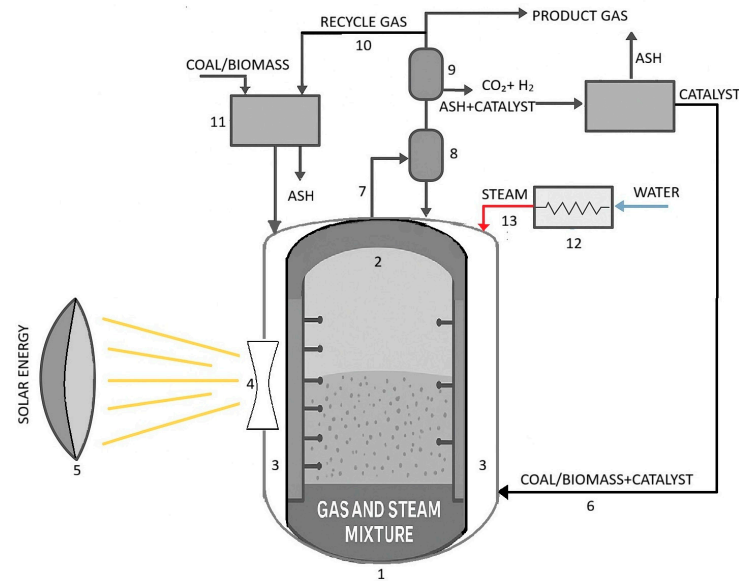

Figure 8. Schematic representation of a preferred gasification system using this new solar-powered fluidised bed gasifier: 1—reactor, 2—reaction zone, 3—refractory honeycomb shell, 4—solar window, 5—concentrator, 6—carbonaceous feedstock, 7—pipe, 8—cyclone, 9—scrubber, 10—recycle gas, 11—back-up furnace, 12—steam generator.

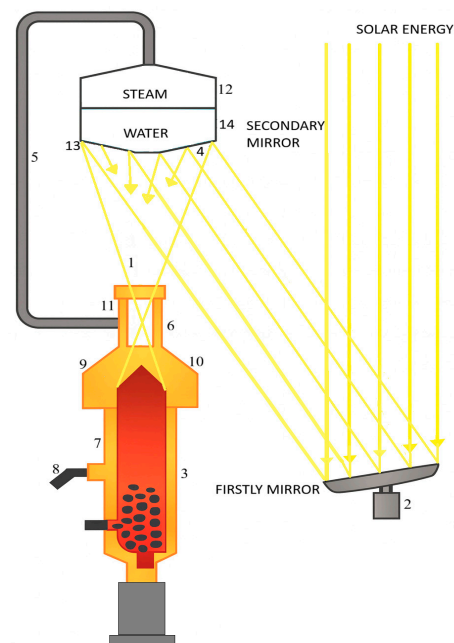

Figure 9. Solar radiation from the array/heliostats, and process steam generation on the rear surface of the secondary mirror: 1—Reflected solar radiation, 2—Heliostat, 3—Reaction chamber, 4—Secondary mirror, 5—Steam supply, 6—Upper part of the reactor, 7—Steam-coal reaction zone, 8—Synthesis gas outlet, 9—Ash, 10—Ash collector, 11—Steam nozzles for window cleaning, 12—Steam generator, 13—Lower side of the mirror, 14—Reflective surface of the mirror.

Approximately 20% of the incident solar flux can be productively used to produce the steam required for the gasification reaction. Neglecting scattering losses, the secondary mirror thus becomes a nominally 100% efficient element, the absorbed solar radiation produces steam in the upper part of the tower where it is needed, and the remaining reflected solar radiation is directed through the inlet window into the reactor, where it triggers the endothermic gasification reaction of steam and coal. Thus, the requirement for the reflectivity of the secondary mirror is reduced to approximately 80%, which can be

easily achieved with conventional metal reflective surfaces. Typically, the reflectivity of mirrors deteriorates over time [15].

Technology limitation: The difficulty of concentrating the rays in the gasification zone (the focus will “drift”) due to the limited mobility of the steam generator, as well as the complicated system of reflectors, the adjustment of which will require a movable reflector support structure.

3.2. Review of European Patents

Although most patents in this field are concentrated in the United States, attention should also be directed to developments originating in Europe and Asia. A global patent search identified only a single invention from the European Union addressing this subject. Patent [16] proposes an alternative approach to enhancing the efficiency and environmental performance of coal gasification through the integration of solar energy. Examination of this patent provides a comparative perspective, underscoring the technological distinctions between U.S. and European approaches to incorporating renewable energy sources into coal conversion systems.

The installation described in Patent [16] was schematized in Figure 10. The main innovation is the replacement of direct thermal exposure to sunlight for fuel gasification with the generation of electrical energy through solar panels for water electrolysis. The oxygen is then fed into the gasifier, and the hydrogen into the synthesis gas. This partially eliminates the need to burn fuel, significantly increasing thermal efficiency and reducing CO₂ emissions. Moreover, the method involves the partial addition of hydrogen (a product of electrolysis) to increase the calorific value of the resulting gas by 21–22% and/or to produce ultra-high-temperature steam for improved steam reforming. At the same time, CO₂ emissions are comparable to those of petroleum fuel, which is a significant step forward in decarbonised fossil fuel energy systems.

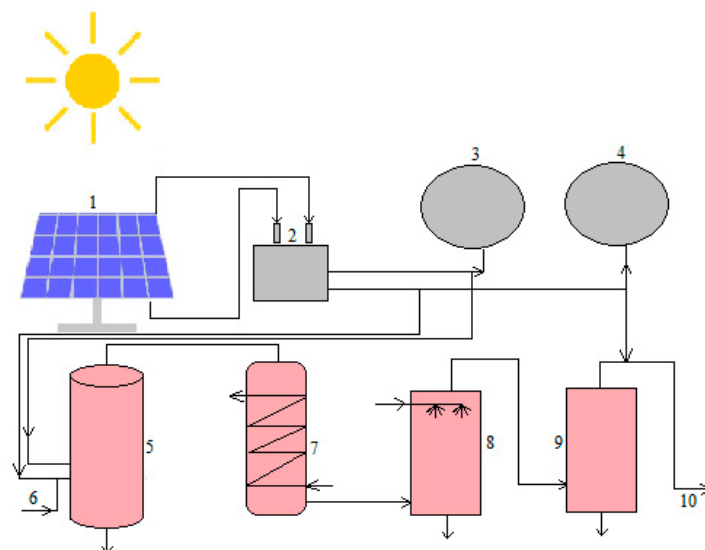

Figure 10. Technological diagram of the invention: 1—solar thermal collectors, 2—electrolyzer, 3, 4—gas holders, 5—gasification reactor, 6—steam line heated by the sun or waste heat, 7—heat recovery, 8—purification, 9—acid gas removal, 10—product gas.

The system uses solar energy to generate direct current through photovoltaic panels or solar thermal collectors (1), which power an electrolyzer (2) that splits water into oxygen and hydrogen, which are stored in gas holders (3, 4). Crushed coal is fed into a high-pressure, high-temperature gasification reactor (5), where it reacts with oxygen and superheated steam (produced via a steam line heated by the sun or waste heat 6) to produce synthesis

gas ($\text{CO} + \text{H}_2$). The synthesis passes through heat recovery (7), purification (8), and acid gas removal (9) units before exiting as clean product gas (10). The process allows for the efficient use of solar energy, converting it into both reactive gases (O_2 , H_2) and thermal energy, resulting in a cleaner and more sustainable coal-to-gas conversion process.

Technology limitation: The technology uses solar energy for water electrolysis rather than directly for gasification. Thus, solar energy undergoes two conversions (light \rightarrow electricity, electricity \rightarrow oxygen, hydrogen). Each stage has its own losses. With single-stage use (light \rightarrow heat), losses are reduced. Supplying pure oxygen to the gasifier requires high material costs compared to air. The production and storage of hydrogen and oxygen in pressurised vessels create safety risks and a complex design.

3.3. Review of Korean Patents

In addition to the patents on solar-powered gasification already discussed, an invention from South Korea has attracted interest.

The installation described in Patent [17] from the Korea Institute of Energy Research and schematized in Figure 11 reveals a self-sustaining coal gasification power generation plant. A distinctive feature of this invention is its hybrid operating modes—with and without solar energy. The innovation aims to integrate renewable energy (solar) into traditional fossil fuel-based energy systems, promoting cleaner and more efficient energy production.

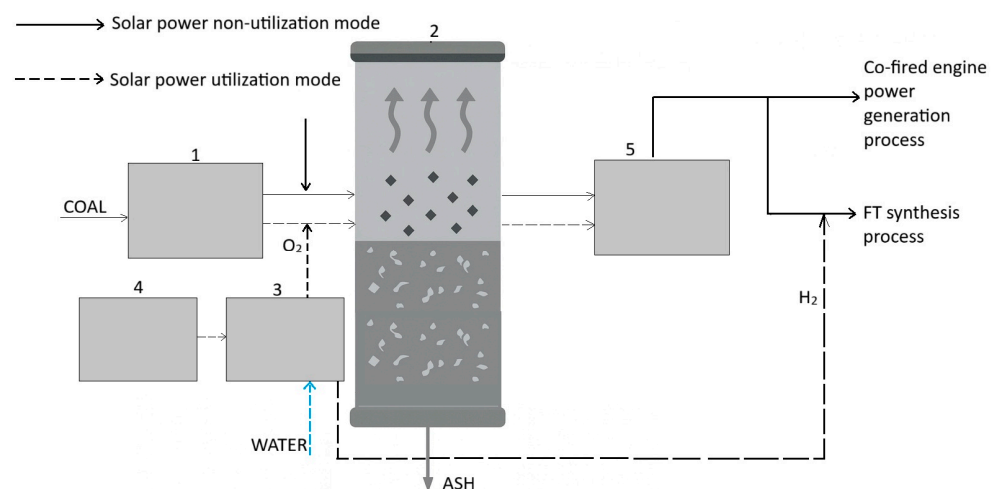

Figure 11. A schematic configuration of an independent coal-based energy production system is shown, including both solar and non-solar operating modes.

This system increases efficiency, minimises environmental impact, and ensures continuous operation regardless of the availability of solar energy.

In solar mode, the system begins with a coal enrichment unit (1) that processes coal by wet grinding, flotation, and thickening to form a coal slurry [12] with reduced ash content and optimised fuel properties. This slurry is sent to a gasification unit (2), where it undergoes partial oxidation using oxygen produced by an electrolyser (3). The electrolyser is powered by electricity generated by photovoltaic modules (4). The gasification process produces synthesis gas, which is purified in a gas cleaning unit (5) using devices such as cyclones, dust filters, etc. The purified synthesis gas and hydrogen produced by electrolysis are then fed into a Fischer-Tropsch synthesis plant to produce synthetic hydrocarbons such as gasoline and diesel fuel. The waste gas from the FT reactor, consisting mainly of hydrogen (60–80%), carbon monoxide (10–20%), and carbon dioxide (10–20%), is used as a low-calorie fuel in a spark-ignition internal combustion engine to generate electricity. In non-solar mode, the system bypasses the solar-powered electrolysis stage. Instead, atmospheric air is used for gasification. Coal slurry and compressed air are fed into the

gasifier (2), and the resulting synthesis gas follows the same purification route (5). Part of this synthesis gas, mixed with diesel fuel, is sent to a dual-fuel compression ignition engine to generate electricity. The remaining synthesis gas is sent to the FT synthesis unit to produce liquid fuel. This dual-mode design allows the plant to operate continuously in both sunny and non-sunny conditions, while maximising energy efficiency and coal utilisation, especially for low-grade coal resources.

Technology limitation: The disadvantages of the invention are common to the previous patent [16]. There are difficulties with the multi-stage conversion of solar energy and the high cost of using oxygen for gasification.

3.4. Review of Chinese Patents

Along with other countries, China is a leader in both the number of patent applications and the number of scientific publications in the field of coal application and processing.

The installation described in Patent [18] from Xi'an Jiaotong University and schematized in Figure 12 discloses a solar-powered supercritical steam gasification reactor for producing hydrogen from biomass. This invention is a new system that combines a solar thermal receiver with a serpentine supercritical water reactor, allowing direct solar heating of biomass and pulp mixtures. The system incorporates a secondary conical concentrator to enhance solar flux at the aperture and improve overall energy efficiency.

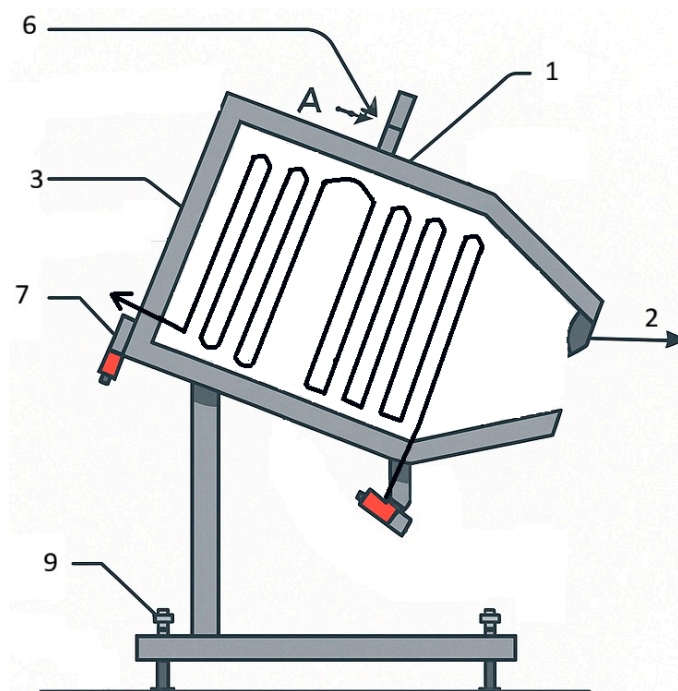

Figure 12. Schematic diagram of the solar energy absorption reactor design: 1—solar absorber, 2—conical secondary solar concentrator, 3—serpentine tubular reactor, 6, 7—thermocouples embedded in the insulation, 9—adjustable screw base.

The installation described in Patent [18] and schematized in Figure 12 shows a cavity solar absorber (marked with the number 1) installed on a tower and supported by a metal frame structure (tower). The absorber is tilted at an angle that corresponds to the azimuth axis of the heliostat tracking system, which maximises the incidence of solar radiation. A conical secondary solar concentrator (2) is in the opening (light collector) of the absorber to increase the density of the solar flux. A serpentine tubular reactor (3) is built into the cavity, divided into a preheating section and a reaction section. The walls of the absorber cavity are constructed of refractory bricks (4) in Figure 13 and wrapped with thermal

insulation (5). Also shown are several thermocouples (6, 7, 8) embedded in the insulation and wall thermocouples (3) for temperature control, as well as an auxiliary electric heater located at the base of the cavity. An adjustable screw base (9) allows for precise adjustment of the angle of inclination. This configuration emphasises the integration of direct solar heat input with the operation of a high-pressure, high-temperature reactor.

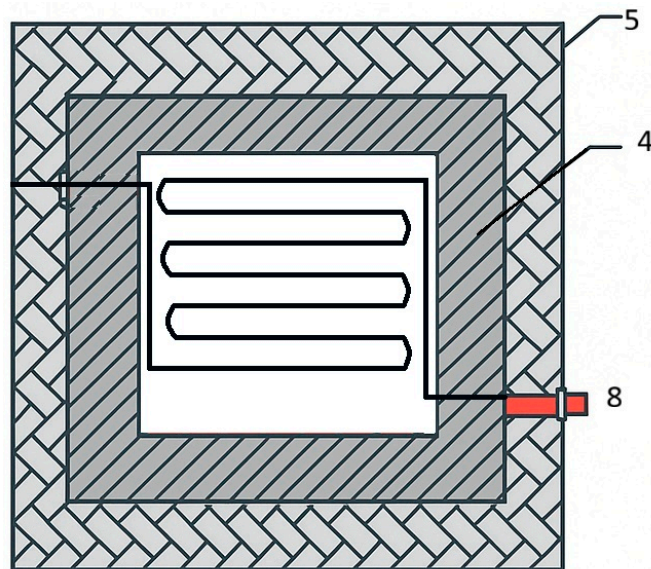

Figure 13. Enlarged view of the cross-section of the solar energy absorption reactor: 4—refractory bricks, 5—thermal insulation, 8—thermocouples embedded in the insulation.

Technology limitation: the design contains a coil with a large number of sharp turns (180°C), which will contribute to the precipitation of coal particles (in the case of coal use) at the turn from the flow. Installation requires additional costs for the pump drive and devices for creating a water-coal suspension. The reactor operates under high temperature and pressure conditions necessary to maintain supercritical parameters, which increases the complexity of the system, material costs, and safety issues.

The installation described in Patent [19] and schematized in Figure 14 describes a fixed-point grid biomass gasification system that integrates point-focusing solar mirrors with biomass gasification technology. The system employs a dynamic tracking mechanism to maintain optimal solar energy concentration on stationary gasification units, thereby improving process efficiency and reducing operating costs.

The technology includes an array of point-focusing solar mirrors (2) that concentrate sunlight onto one or more stationary biomass gasification units (1) at temperatures of $200\text{--}1000^\circ\text{C}$. Each mirror is mounted on a dual-axis tracking system (horizontal and vertical axes) controlled by an integrated electronic system (4), which ensures continuous focal alignment as the sun moves. Secondary reflectors (3) optionally increase the concentration of energy. In this patent, solar energy is used as the primary heat source to control the biomass gasification process. Solar thermal energy either directly heats the biomass or indirectly transfers heat through a heat exchanger, replacing or supplementing traditional fossil fuel-based heating methods. This solar-based approach improves sustainability by reducing dependence on external energy sources while maintaining the efficiency of high-temperature gasification.

Technology limitation: Although the design overcomes the limitations of traditional tower and dish systems by enabling the scaling of distributed applications, practical implementation may face challenges in maintaining precise focal alignment under varying environmental conditions and integrating secondary focusing optics.

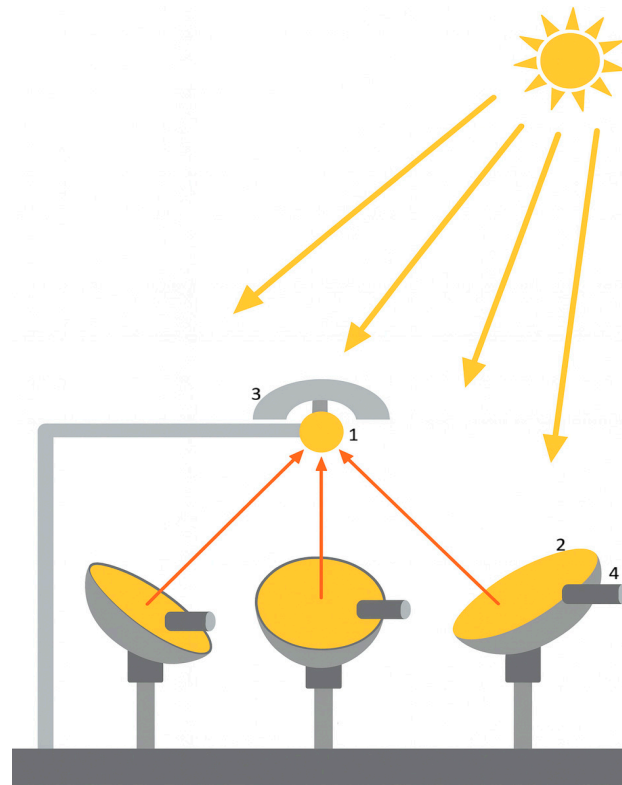

Figure 14. Fixed-point solar tracking biomass gasification system.

Another Chinese patent [20] schematized in Figure 15 presents a method for converting *Eichhornia crassipes* (water hyacinth) into combustible gas through biomass gasification using solar energy. The method of converting water hyacinth involves converting energetic “water hyacinth” into “gas” by compressing and heating it with solar energy at a certain water content. This method consists of the following: build a large-scale gasifier in or near a water source (e.g., a lake), install water hyacinth and add it to the gasifier’s biomass hopper with a certain water content, isolate it from oxygen (air), and at the same time collect sunlight to create high temperatures. The cooled fuel gas contains biomass energy and solar energy. Uncooled fuel gas can be directly used for combustion and power generation. The proposed system combines biomass pretreatment through mechanical dehydration and anaerobic conditions with solar thermal energy to achieve high-temperature gasification.

Solar radiation is concentrated using parabolic mirrors and redirected using a rotating “light transmission head” to achieve a temperature inside the reactor exceeding 700 °C. Under these conditions, organic components (C, H, O, N compounds) undergo thermal cracking, resulting in a synthesis gas mixture rich in H_2 , CO, CH_4 , and NH_3 . In Figure 15, component (1) is the base of the gasifier, providing structural support. Component (2) is the absorber heating chamber containing heating tubes (3) integrated into the biomass chamber (4), where compressed water hyacinth is located. Concentrated solar rays (5) are directed into a rotating light transmission head (6) system, which receives sunlight (7) reflected from a parabolic mirror (8). The resulting gas exits through the gas outlet (9), and liquid byproducts are discharged through the liquid outlet (10).

Technology limitation: The complexity of creating a “hyacinth” device. The formation of ammonia, NH_3 , during subsequent combustion will cause harmful nitrogen oxide emissions.

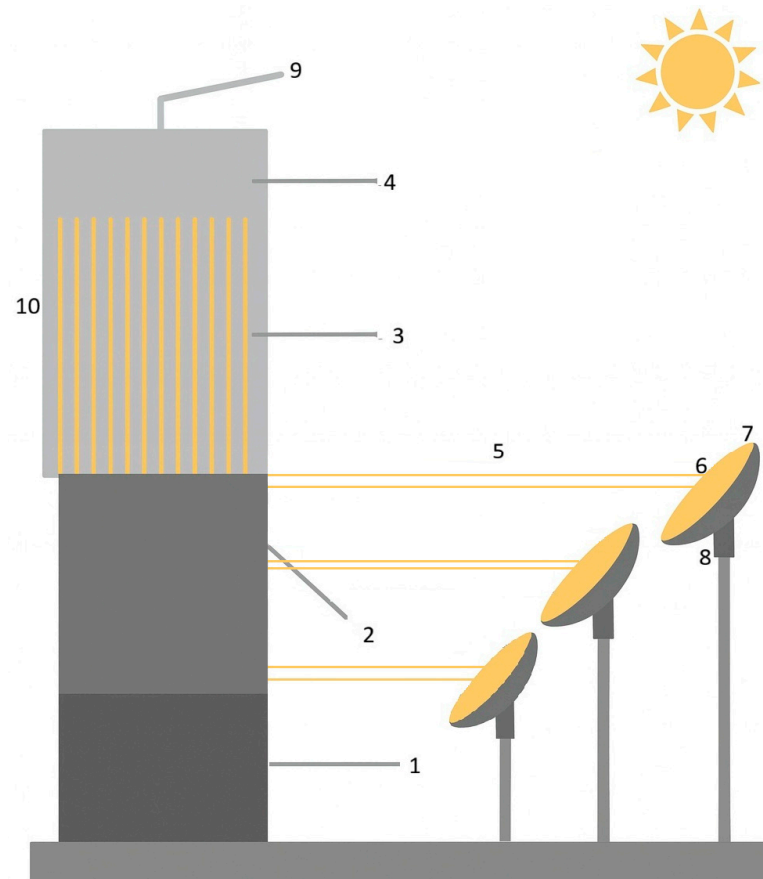

Figure 15. Schematic diagram of a solar gasifier.

Patent [21] schematized in Figure 16 describes an innovative approach to producing hydrogen from biomass through supercritical water gasification (SCWG) using direct solar energy as a heat source. This method incorporates a multi-tray solar concentrator system with a supercritical water reactor, achieving high hydrogen yield without dependence on external fuel sources. Compared to other traditional solar thermochemical hydrogen production methods (which typically require $>1200\text{ }^{\circ}\text{C}$), this method successfully reduces the reaction temperature to below $350\text{ }^{\circ}\text{C}$, thereby simplifying material selection and reducing costs.

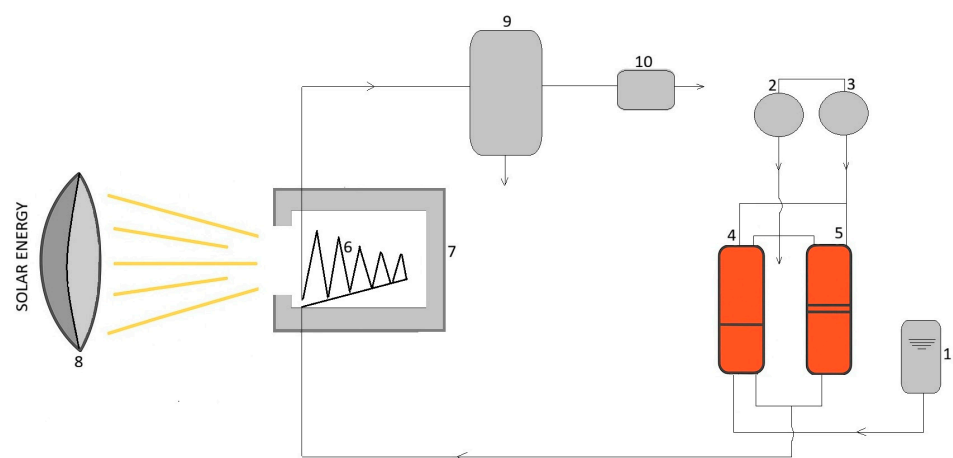

Figure 16. Device for producing hydrogen by supercritical gasification of biomass with water in combination with multi-disc focusing heating: 1—Biomass storage tank, 2, 3—High-pressure plunger pumps, 4, 5—Biomass and water feed injectors, 6—Reactor, 7—Absorber chamber, 8—Solar concentrator grid, 9—Gas and liquid separator, 10—Wet gas flow meter.

The technology uses a system in which biomass mixed with water is pumped under high pressure into a reactor (6), where supercritical gasification takes place. The reactor is in an absorber chamber (7), which is heated by a multi-parabolic solar concentrator system (8). These dishes automatically track the movement of the sun and focus its energy on absorption, achieving intense, localised heating. The direct use of solar energy provides the heat necessary to maintain supercritical conditions (over 374 °C and 22 MPa) in the reactor, which allows for the efficient conversion of biomass into hydrogen-rich gas without external heating sources.

Technology limitation: Like invention [18], the complexity of creating and maintaining critical parameters. In addition, an open window for sunlight to enter the reactor (6) will cause heat loss through convection of hot air flow.

3.5. Review of Russian Patents

At the end of the patent review, an invention from the Russian Federation [22] caught our attention. This invention schematized in Figure 17 proposes a method and solar installation for producing artificial liquid fuel from carbon-containing materials of plant origin using a combination of pyrolysis and photothermolysis. The technology is based on a two-stage process: first, the raw materials are subjected to pyrolysis at a temperature of 450 °C and a pressure of 150 atm, then the resulting gaseous products, such as CH₄, C₂H₄, C_mH_n, CO, H₂, and CO₂, undergo photothermolysis under concentrated solar radiation at a temperature of 200–240 °C. The final stage involves passing the activated gases through a paraffin layer with an iron catalyst, where they are converted into liquid fuel. Although the patent offers an innovative multi-stage approach combining solar energy with catalytic liquefaction, it also presents technical complexity and potential scalability issues. Nevertheless, this system reflects Russia's efforts to expand the feedstock base for renewable fuels using solar thermal processes.

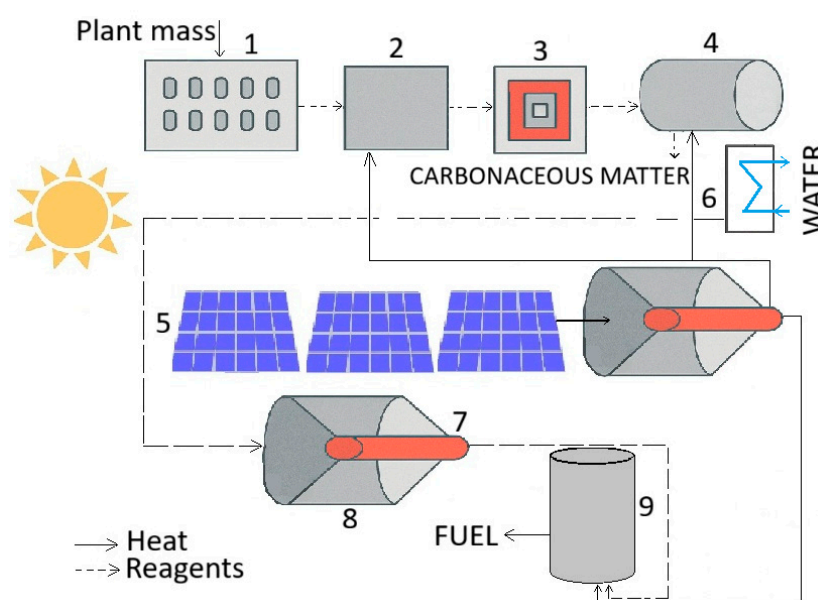

Figure 17. General view of the liquid fuel production installation: 1—Twin-screw grinder, 2—Solar or electric dryer, 3—Calibration module, 4—Autoclave pyrolyzer, 5—Heating element, 6—Condenser, 7—Photothermal reactor, 8—Solar concentrator, 9—Slurry reactor.

Technology limitation: Despite the originality of the idea and its focus on renewable energy sources, the technology is overly complex from an engineering standpoint and requires a high degree of automation, a stable solar resource, and high costs for thermal

insulation and process control. In addition, the use of a catalyst increases the cost of the system.

3.6. Author's Concept of a Solar Gasifier

Based on a review of patents from various countries on fuel gasification using solar energy and an analysis of the advantages and disadvantages of the inventions presented, this article proposes a proprietary concept for a device for steam gasification of coal using solar heat, suitable for conditions in Kazakhstan and Central Asia. The described device has been filed with the Patent Office of the Republic of Kazakhstan, as noted in Section 6. Patents. As shown in the above review, most authors use solar heat directly in the gasifier or through photovoltaics for water electrolysis with subsequent introduction of oxygen and hydrogen separately at different stages. The main idea is to obtain high-temperature steam (800–900 °C) using solar heat in the first stage, which, as shown by inventions [10,15], is quite possible, and then use this steam in a coal gasifier simultaneously as a heat source (heat carrier) and directly as steam itself.

The installation schematized in Figure 18 operates as follows: crushed coal is fed into the upper part of the gasifier (1) by means of a low-power fan (2). The fan acts as a natural backflow preventer for the synthesis gas flow, preventing it from escaping through the upper part of the gasifier (1). Superheated steam is fed tangentially into the lower part of the device through a pipeline (3) in counterflow to the coal. To obtain steam, it is proposed to install a parabolic dish solar reflector (4), which focuses solar energy onto a water heat exchanger, which is a vertical pipe-in-pipe type pipeline (5). The water in the inter-pipe space of the heat exchanger will evaporate under the action of concentrated solar radiation, forming superheated steam. In the inner pipe of the heat exchanger, crushed coal flows by gravity and absorbs the heat remaining after steam formation, passing through the inner wall of the heat exchanger. The superheated steam enters the lower part of the gasifier reactor tangentially (3). The tangential flow is created to intensify turbulence and accelerate the process to draw in the coal dust and retain it in the reaction zone so that the dust has time to react and does not fall under the force of gravity. The steam temperature is about 900 °C, which is the main condition for steam gasification. The lower part (directly the reaction zone (5)) of the gasifier is insulated by a glass cylindrical wall (6), while the upper outlet (for gas synthesis) part of the gasifier is thermally insulated with mineral wool (7) to minimise heat loss from the structure and prevent heat leakage. The glass partition (6) creates a “greenhouse” inside: sunlight passes through the glass by radiation and is absorbed by the metal wall (5); the glass prevents heat from escaping back into the environment by convection. Synthesis gas collects at the top of the gasifier and exits through a special pipeline (8). The outgoing synthesis gas has a high temperature of at least 600 °C [23] for biomass and at least 900 °C [7] for coal [24,25], which creates favourable conditions for its utilisation in a special recuperator (9) by analogy with patents [9,16]. Recovery significantly increases the overall energy efficiency of the gasification process and reduces the temperature of the synthesis gas for subsequent purification from dust, etc. To do this, hot synthesis gas is fed into the heat exchanger (9) inside the pipeline. Feed water is fed into the intertube space of this heat exchanger. As a result, the water is heated and partially boils, while the gas cools down. As a result of recovery, the water reaches a boiling state or a water-vapour mixture. The feed pump (10) creates the necessary excess pressure in the system, which causes the steam-water mixture to move, followed by the synthesis gas. After the heat exchanger, the steam-water mixture enters the intertube space of the reaction zone (5) through the inlet pipe (11), where the steam is superheated and reaches the required temperature. The steam is then fed through the outlet pipe (12) to the lower part of the internal pipeline of the gasifier (1) and provides steam gasification. Upon

completion of the gasification process, coke [26] + ash are discharged downward. In the absence of solar energy (at night), the gasifier operates in a traditional mode with partial coal combustion. For this purpose, air is fed into the gasifier together with steam.

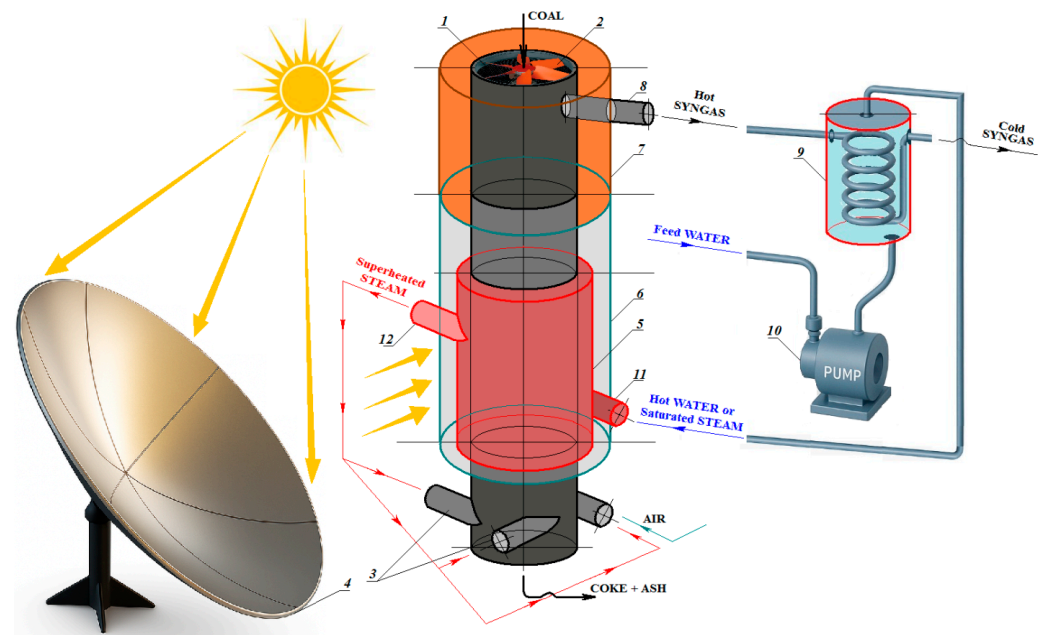

Figure 18. Steam gasifier based on a solar heat source.

Technology limitation: The proposed technology utilizes solar energy and does not include heat storage system. At night and in cloudy conditions, the device will switch to gasifier mode with burning fossil fuels, resulting in greenhouse gas emissions. Work about these limitations is planned for the near future.

4. Discussion

A comparative analysis of the qualitative characteristics of the gasifiers under consideration is given in Table 2.

Table 2 presented allows us to make the following conclusions:

- *The applicability to Kazakhstan* coals is broad due to the country's rich diversity of coals. It makes gasification technology very attractive in this region. Kazakhstani technologies are currently limited to the combustion of fossil fuels without RES. The most developed technologies in the country according to review's topic are coking [26].
- *The simultaneous use of solar concentrating technology and fossil fuel gasification* was previously not considered competitive because solar gasification was understudied enough in the 20th century due to the high cost of solar technologies. Interest in the topic has increased in the 21st century, as costs have significantly decreased with the development of industrial solar energy technology. Research activity on this topic has increased in recent years, with new articles [27–29] and conference papers [30] appearing in publication. The results are of interest to both the review authors and potential researchers.
- Each inventive solution is undoubtedly *novel*, which is a mandatory requirement of the patent office in any state.
- The selecting technologies criterion for the patent analysis was the application of solar energy for gasification. Thus, all technologies contribute to the planet's *sustainable development*, which leads to a reduction in greenhouse gas emissions. A review of gasification technologies without RES has already been conducted previously [6].

- The *geography* of research indicates the greatest interest in solar gasification in USA. In recent years, China has significantly increased its research activity in this field. The other countries reviewed lag behind the two obvious leaders. It should be noted that Kazakhstan has not yet any results relevant to the review topic. The authors are planning extensive research using Kazakhstani fuels. The first priority is to obtain a patent for the invention.

Table 2. Comparative analysis of the considered patents by key parameters.

Country	Patents	Year	Key Parameters			Temperature, °C
			Reactor Type	Energy Source	Limitations	
U.S.	[7]	1976	Direct solar	Concentrated solar radiation for gasification	Inorganic impurities must be removed	600–700
	[8]	1983	Direct solar	Concentrated solar radiation for gasification	Rapid dust deposits on the quartz window during coal use	627–827
	[11]	1984	Indirect solar during the melt salt	Concentrated solar radiation for melting salt before gasification	Transparent windows can become contaminated or cloudy due to reaction product deposits in the case of coal	not specified
	[12]	1997	Direct solar	Concentrated solar radiation for gasification	The necessity of creating water-coal suspensions creation	not specified
	[13]	2008	Direct solar	Concentrated solar radiation for gasification	Rapid dust deposits on the window during coal use. Technology is preferred for biofuels	950–1400
	[14]	2009	Direct solar	Concentrated solar radiation for gasification	Rapid dust deposits on the window during coal use	950–1400
	[10]	1981	Direct solar	Concentrated solar radiation for steam generation and gasification	Accumulate condensate of gold-oil components	1093
	[15]	1980	Indirect solar	Concentrated solar radiation for steam generation (20%) and gasification (80%)	The difficulty of concentrating the rays in the gasification zone	not specified
Europe	[16]	2001	PV-assisted	Solar radiation for PV	Technology uses solar energy for water electrolysis rather than directly for gasification	-
Korea	[17]	2020	PV-assisted	Solar radiation for PV	Multi-stage conversion of solar energy	not specified
China	[18]	2011	Direct solar	Concentrated solar radiation for gasification	The necessity of creating water-coal suspensions creation	not specified
	[19]	2013	Direct solar	Concentrated solar radiation for gasification	Technology is preferred for biofuels	200–1000
	[20]	2010	Direct solar	Concentrated solar radiation for gasification	The necessity of “water hyacinth” creation	700
	[21]	2009	Direct solar	Concentrated solar radiation for gasification	Complexity of creating and maintaining critical parameters	1227
Russia	[22]	2006	Hybrid configurations	Concentrated solar radiation for gasification	The use of a catalyst increases the cost of the system	450
Kazakhstan	The proposed installation	2025	Direct solar	Concentrated solar radiation for steam generation (80%) and gasification (20%)	-	800–900

The proposed installation (own concept) eliminates several disadvantages found in earlier designs, namely:

- No need for a pseudo-fluidised coal bed. In the proposed configuration, the fuel is fed by gravity into the reaction zone.
- No contamination of the glass wall. In previous designs, the transparent partition often fogged up, became covered with resin and oil condensates, or accumulated coal

- dust, which hindered the passage of solar radiation. In the proposed system, the glass wall does not come into direct contact with the fuel.
- No external steam supply required. Some inventions rely on steam generation from external sources, such as partial combustion of fuel. In the proposed design, steam is both generated and superheated in two stages—within the recuperator and in the focal point of the solar concentrator.
 - No catalyst required. While certain prior systems required the use of costly catalysts, the proposed installation operates without them.

5. Conclusions

A review of patents shows that most inventions—except for patents [17]—are more than ten years old, with the earliest dating back to 1976. Previous reviews of gasification patents have primarily focused on the statistical and quantitative analysis of developments in the field of converting carbon-containing materials. In contrast, the present work emphasises the technological and engineering solutions associated with the integration of solar energy into gasification processes. This perspective makes it possible to evaluate the potential for enhancing energy efficiency, reducing the carbon footprint, and advancing a novel method of solar gasification.

In most patents, except for [15], solar energy is used separately, either for gasification or for steam generation. In the proposed design, water vapour is both a source of heat (heat transfer medium) and a chemical substance that directly provides steam gasification. Combining the two processes into one allows for the efficient use of solar energy: part of the radiation is absorbed by the steam–water mixture, and the remaining heat is absorbed by the coal without being lost to the environment.

This design is free of the disadvantages of its counterparts and is a simplified design with a high degree of adaptability to various types of fuel, including brown coal, biomass, and other carbon-containing materials. Thanks to its reduced complexity of assembly and operation, this development can be effectively implemented in industrial production using traditional metalworking technologies.

6. Patents

Based on present research, a patent application was filed with the National Institute of Intellectual Property of the Republic of Kazakhstan. Application number is 415028.

Author Contributions: Conceptualization, M.Z. and A.O.; methodology, M.Z.; validation, M.Z. and D.P.; formal analysis, M.Z., A.O. and D.P.; investigation, M.Z. and A.O.; resources, M.Z. and A.O.; data curation, M.Z. and A.O.; writing—original draft, A.O.; writing—review and editing, M.Z. and A.O.; visualization, M.Z. and A.O.; supervision, M.Z.; project administration, M.Z.; funding acquisition, D.P. All authors have read and agreed to the published version of the manuscript.

Funding: This research was funded by the authors' own expense.

Data Availability Statement: No new data were created or analyzed in this study.

Acknowledgments: The authors express their acknowledge to the Ministry of Culture and Information of the Republic of Kazakhstan for general support of the research within the framework of the grant program “Tәuelsizdik Urpaktary-2025” (direction “Science”) on the research topic “Improving the coal gasification technology from coal deposits of Kazakhstan using solar energy”.

Conflicts of Interest: The authors declare no conflict of interest.

Future Research Directions: At the present stage, the design is undergoing patent registration in the Republic of Kazakhstan, which will confirm its originality and novelty in both technical and technological aspects. The subsequent phase of research will focus on detailed engineering

calculations, computer simulations, and the development of a functional laboratory prototype for experimental validation.

Abbreviations

The following abbreviations are used in this manuscript:

CIS	Commonwealth of Independent States (Former USSR)
FT	Fischer-Tropsch (synthesis)
HEPA	High Efficiency Particulate Air
RES	Renewable energy sources
SCWG	Supercritical Water Gasification
SMR	Steam Methane Reforming
U.S.	The United States of America
WCS	Water-Coal Suspensions

References

- Zhumagulov, M.G.; Dolgov, M.V.; Baubek, A.A.; Gribkov, A.M. Comparative analysis of swirl burner and cross jet burner in terms of efficiency and environmental performance. *J. Combust.* **2023**, *2023*, 1692296. [[CrossRef](#)]
- Dostiyarov, A.M.; Sadykova, S.B. Micro-modular air driven combustion nozzle. Experimental and Numerical Modelling Studies towards Optimal Geometric Design. *Therm. Sci.* **2022**, *26*, 1557–1566. [[CrossRef](#)]
- Zhumagulov, M.G.; Omirbayeva, A.O. Review of coal gasification technologies and their applicability in Kazakhstan. *Bull. Toraiyrov Univ.* **2025**, *1*, 132–146. [[CrossRef](#)]
- Dequan, X.; Gu, X.; Yanjun, D. Concentrating solar assisted biomass-to-fuel conversion through gasification: A review. *Front. Energy Res.* **2022**, *10*, 1029477. [[CrossRef](#)]
- Shunchun, Y.; Youxing, W.; Zhimin, L.; Songjie, G.; Jinzheng, C.; Ziyu, Y. Review of Research Progress on Concentrated Solar Energy Utilization System. *Renewables* **2023**, *1*, 397–414. [[CrossRef](#)]
- Seong, G.M.; Yung, H.J.; Yoonjung, K.; Yonsoo, C. A Patent Analysis on Coal Gasification Technology. *Clean Technol.* **2012**, *18*, 144–154. [[CrossRef](#)]
- Antal, M.J. Method for Producing Synthetic Fuels from Solid Waste. U.S. Patent 3,993,458, 23 November 1976.
- Aiman, W.R.; Gregg, D.W. Solar Coal Gasification Reactor with Pyrolysis Gas Recycles. U.S. Patent 4,415,339, 15 November 1983.
- Puig-Arnabat, M.; Tora, E.A.; Bruno, J.C.; Coronas, A. State of the art on reactor designs for solar gasification of carbonaceous feedstock. *Sol. Energy* **2013**, *97*, 67–84. [[CrossRef](#)]
- Qader, S.A. Solar Heated Fluidized Bed Gasification System. U.S. Patent 4,290,779, 22 September 1981.
- Jakahi, D.Y. Apparatus for Storing Solar Energy in Synthetic Fuels. U.S. Patent 4,455,153, 19 June 1984.
- Epstein, M. Solar Energy Gasification of Solid Carbonaceous Material in Liquid Dispersion. U.S. Patent US5647877, 15 July 1997.
- Weimer, A.W.; Davidson, R.M.; Diver, R.B.; Miller, J.E.; Perkins, C.L.; Steinfeld, A. Rapid Solar-Thermal Conversion of Biomass to Syngas. U.S. Patent A20080086946A1, 17 April 2008.
- Perkins, C.; Jovanovic, Z.; Hilton, C.; Simmons, W.; Minden, A. Systems and Methods for an Integrated Solar Driven Chemical Plant. U.S. Patent 20100249468A1, 30 September 2010.
- Gregg, D.W. Apparatus and Method for Solar Coal Gasification. U.S. Patent 4,229,184, 21 October 1980.
- Katayama, Y. Method for the Gasification of Coal. European Patent EP1154008A2, 14 November 2001.
- Won, R.H.; Hong, J.; Joon, Y.S.; Min, Y.S.; Tae, L.H.; Won, S.M.; Young, M.T. Standalone Energy Production Plant System Using Coal Resources. Korean Patent KR102086652B1, 17 February 2020. (In Korean).
- Guo, L.; Chen, J.; Zhang, X.; Lü, Y. Solar-Thermal Driven Biomass Supercritical Water Gasification Hydrogen Production Absorption Reactor. China Patent CN101597025B, 22 June 2011. (In Chinese).
- Chengdu Aonengpu Technology Co., Ltd. Fixed-Point Array Solar Biomass Gasification System. China Patent CN202757284U, 27 February 2013. (In Chinese).
- Feng, Y. Method for Converting Water Hyacinth into Energy. China Patent CN101812328A, 25 August 2010. (In Chinese).
- Guo, L.; Lü, Y.; Zhang, X. Biomass Supercritical Water Gasification and Multi-Dish Solar Thermal Coupled Hydrogen Production Device and Method. China Patent CN101597027A, 9 December 2009. (In Chinese).
- Ivanchevskaya, E.S.; Rabbimov, R.T.; Strebkov, D.S.; Trushevskiy, S.N. Method and Solar Installation for Producing Artificial Liquid Fuel from Carbon-Containing Materials. Russian Patent RU2277119C1, 27 May 2006. (In Russian).
- Setioputro, T.; Kosim, M.; Kasda; Sukwadi, R.; Basuki, W.W.; Saputra, D.I. Investigation of reactor temperature and performance of syngas cooling system for vacuum gasification of soaked biomass. *Case Stud. Therm. Eng.* **2023**, *50*, 103430. [[CrossRef](#)]

24. Junho, O.; Ye, I.-S.; Park, S.; Ryu, C.; Park, S.K. Modeling and analysis of a syngas cooler with concentric evaporator channels in a coal gasification process. *Korean J. Chem. Eng.* **2014**, *31*, 2136–2144. [[CrossRef](#)]
25. Phillips, J.N. A Study of the Off-Design Performance of Integrated Coal Gasification Combined-Cycle Power Plants. Ph.D. Thesis, Stanford University, Stanford, CA, USA, June 1986.
26. Zhumagulov, M.G.; Sadykova, S.B. Thermooxidative Coking of Poorly Clinkering Coal. *Coke Chem.* **2020**, *63*, 369–377. [[CrossRef](#)]
27. Zhang, Q.; Shan, S.; Yu, J.; Zhou, Z.; Luo, K.H. Coal gasification process driven by concentrated solar radiation for carbon neutralization: Reaction and energy characteristics. *Chem. Eng. J.* **2022**, *450*, 138286. [[CrossRef](#)]
28. Wang, S.; Zhu, X.; Liu, Q.; Bai, Z.; Wang, H.; Jiao, F.; Huang, X.; Gu, Y. Design and experimental study of solar-driven biomass gasification based on direct irradiation solar thermochemical reactor. *Chem. Eng. J.* **2024**, *500*, 157062. [[CrossRef](#)]
29. Suárez-Almeida, M.; Gómez-Barea, A.; Salinero, J. Design and performance analysis of a solar dual fluidized bed gasifier. *Fuel* **2023**, *338*, 127031. [[CrossRef](#)]
30. Acikalin, G.; Dincer, I. Life Cycle Assessment of Different Energy Sources for Municipal Gasification System (12 December 2023). In Proceedings of the 11th Global Conference on Global Warming, Istanbul, Turkey, 14–16 June 2023. [[CrossRef](#)]

Disclaimer/Publisher’s Note: The statements, opinions and data contained in all publications are solely those of the individual author(s) and contributor(s) and not of MDPI and/or the editor(s). MDPI and/or the editor(s) disclaim responsibility for any injury to people or property resulting from any ideas, methods, instructions or products referred to in the content.