

Safe Working Procedures for Electric Vehicle Maintenance

Original

Safe Working Procedures for Electric Vehicle Maintenance / Colella, P., Pons, E.. - In: IEEE INDUSTRY APPLICATIONS MAGAZINE. - ISSN 1077-2618. - ELETTRONICO. - 31:6(2025), pp. 67-75. [10.1109/mias.2025.3591419]

Availability:

This version is available at: 11583/3004475 since: 2025-10-26T14:48:44Z

Publisher:

IEEE

Published

DOI:10.1109/mias.2025.3591419

Terms of use:

This article is made available under terms and conditions as specified in the corresponding bibliographic description in the repository

Publisher copyright

IEEE postprint/Author's Accepted Manuscript

©2025 IEEE. Personal use of this material is permitted. Permission from IEEE must be obtained for all other uses, in any current or future media, including reprinting/republishing this material for advertising or promotional purposes, creating new collecting works, for resale or lists, or reuse of any copyrighted component of this work in other works.

(Article begins on next page)

Safe Working Procedures for Electric Vehicle Maintenance

Pietro Colella, *Member IEEE*, Enrico Pons, *Senior Member IEEE*

Abstract—The surge in Electric Vehicle (EV) adoption marks a crucial shift towards sustainable transportation solutions driven by environmental concerns. EVs offer various advantages, including reduced emissions, enhanced energy efficiency, and quieter operation. However, the EVs are also affected by faults and crashes, requiring personnel to repair them. Currently, no International, American, or European Standard is dedicated to work activities on EVs. This paper addresses the regulatory gap by examining the properties of the EVs, the risk sources, and the available standards related to generic electrical installations, or EV emergency scenarios. The study proposes suggestions for workshop setup, organizational procedures, and operational protocols to ensure safety during EV maintenance activities. Moreover, the processes of evaluating and managing the electric risks are presented for a real case study, in which technicians replace cells in a battery pack of an electric bus.

Index Terms—Electric vehicles, Risk analysis, Safety management, Batteries, Maintenance, Electrical works, Electrical equipment industry, Process planning.

ACRONYMS

AC	Alternating Current
BCU	Battery Control Unit
BEV	Battery Electric Vehicle
BM	Battery Module
BMS	Battery Management System
BP	Battery Pack
DC	Direct Current
EV	Electric Vehicle
FEV	Full Electric Vehicle
HEV	Hybrid Electric Vehicle
ICE	Internal Combustion Engine
LWZ	Live Working Zone
PPE	Personal Protective Equipment
TR	Thermal Runaway
VR	Vicinity Zone

I. INTRODUCTION

In recent years, the automotive industry has witnessed a notable surge in the diffusion of Electric Vehicles (EVs), marking a significant transition towards sustainable transportation solutions [1]. This transition stems from growing concerns over environmental sustainability and the imperative to mitigate the adverse effects of traditional fossil fuel-dependent vehicles on the ecosystem. The proliferation of EVs represents a pivotal step towards achieving cleaner and greener mobility solutions, thereby addressing pressing global challenges such as climate change and air pollution [2].

Electric vehicles offer some advantages over their conventional counterparts, ranging from reduced greenhouse gas

emissions to enhanced energy efficiency. The general benefits of EVs encompass lower operating costs, decreased reliance on finite fossil fuels, and quieter operation, contributing to a more sustainable urban landscape [3]. Moreover, EVs boast advanced technological features and innovations, including regenerative braking systems and seamless integration with renewable energy sources, further enhancing their appeal to consumers and policymakers alike.

Despite the evident advantages of electric vehicles, it is imperative to acknowledge that like any other automotive technology, they are not immune to malfunctions or accidents. As with traditional vehicles, EVs can experience breakdowns and collisions, necessitating preparedness to effectively manage associated risks and mitigate potential hazards. The Standard ISO 6469 provides the safety specifications that the manufacturers of EVs shall adopt [4]–[6]. These precautions increase the people’s safety in case of a crash.

Moreover, several international and national agencies, such as the American “National Fire Protection Association” (NFPA) and the Italian “Corpo Nazionale dei Vigili del Fuoco,” have provided operational procedures for managing emergency scenarios involving crashed electric vehicles [7], [8].

Unfortunately, no International, American, or European standard is specifically dedicated to electrical work on vehicles in non-emergency conditions. In fact, both the NFPA 70E and the European Standard EN 50110-1, which provide reference guidelines for electrical works, explicitly exclude onboard systems [9], [10]. As a result, maintenance personnel solely rely on EN 50110-1 and emergency response guidelines as their primary references, even when these documents do not cover the scope of their activities. A regulatory framework to address this gap is crucial due to the growing number of EVs.

This article, which is an extended version of a conference paper published by the Authors [11], aims to contribute to this mission by discussing the risks and mitigation strategies of non-emergency electrical work on vehicles. The paper is structured as follows. Section II characterizes the main type of EVs. Section III describes the risk sources that should be considered during the execution of electrical work on an EV. Section IV focuses on the state-of-the-art procedures to evaluate and manage the electric risk working on EVs, both in workshops and in emergency conditions occurring after a car crash. Section V proposes recommendations to work on EVs, contributing to filling gaps in current regulatory documents. Finally, an example of the implementation of these recommendations is reported in Section VI, where a real case study is presented and discussed.

II. BATTERY ELECTRIC VEHICLES

EVs are usually fed by on-board batteries. For this reason, they are referred to as Battery Electric Vehicles (BEVs). More in detail, BEVs can be grouped into two main categories: Full Electric Vehicles (FEVs) and Hybrid Electric Vehicles (HEVs). In the following subsections, the main characteristics of these vehicles will be provided. Although various configurations are possible, the battery pack constitutes the common risk factor across all vehicle types; nevertheless, understanding the main characteristics of each vehicle category is essential to assess the hazards associated with specific maintenance activities.

A. Full Electric

FEVs are automobiles powered solely by rechargeable battery packs. They rely entirely on electric propulsion for locomotion. FEVs can be particularly effective in reducing the CO_2 emissions if adopted in scenarios characterized by high penetration of Renewable Energy Sources. Additionally, FEVs typically require low maintenance due to their simpler mechanical design and fewer moving parts. The power-train architecture of a FEVs refers to the arrangement of components responsible for generating and transmitting power to the wheels. Common configurations include:

- Single motor with transmission, where a single electric motor drives the wheels through a transmission system.
- Dual motor with all-wheel drive, where separate electric motors power the front and rear axles, providing enhanced traction and performance.
- Motor at each wheel, where individual electric motors are mounted directly at each wheel, offering precise control and potentially improved efficiency [12].

Electric motors used in FEVs are typically three-phase alternating current motors [13], [14]. They can be categorized based on their construction, including synchronous motors with permanent magnets and asynchronous motors.

The Battery Pack (BP) is a critical component of FEVs, storing and supplying electrical energy to power the vehicle. Typically, key properties of the battery pack include:

- Energy density, which is the amount of energy stored per unit volume or weight, impacting the vehicle's range and performance [15].
- Rated voltage, which is the electrical potential difference provided by the battery pack, typically ranging from 300 V to over 1000 V [16].
- Rated capacity, which is the total amount of energy the battery pack can store, typically expressed in kWh (up to 100 kWh) [16] in cars, but even larger for some trucks and other larger vehicles.

The geometry of the BP, along with its placement and the structural design of the vehicle, are also important properties for its characterization. In fact, the BPs can also be categorized considering the installation strategies, which impact its shape. The main configurations are depicted in Fig. 1, and include [17]:

- “Floor”, where the batteries form a slab positioned between the two axles.

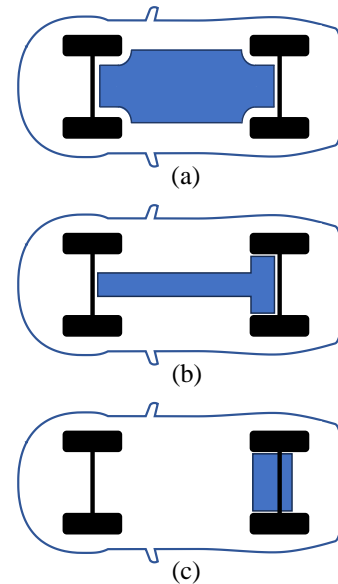

Fig. 1. BP configurations: (a) “Floor”, (b) “T”, (c) “Rear”

- “T”, where the batteries are placed between the two axles in two directions.
- “Rear”, which is rare and typically adopted when small capacity is required.

B. Hybrid

Hybrid Electric Vehicles HEVs are vehicles that utilize a combination of two or more power sources for propulsion, typically comprising an Internal Combustion Engine (ICE) and an electric motor. The integration of these power sources allows HEVs to achieve improved fuel efficiency and reduced emissions compared to traditional vehicles solely powered by ICEs. Considering their power-train architectures, they can be classified into two groups: Series and Parallel HEVs.

Series HEVs feature an architecture where the ICE is used solely to generate electricity to power the electric motor. The ICE does not directly drive the wheels but serves as a generator to charge the vehicle's battery pack. In this way, the ICE is kinetically released from the wheels, can operate at maximum efficiency, and provides the average power needed for motion, while the instantaneous part is provided by the battery, which is smaller in size (thus less expensive) than in a FEV.

Parallel HEVs feature an architecture where both the ICE and the electric motor are mechanically connected to the wheels, allowing for different combinations of power from both sources. They can operate using either the ICE, the electric motor, or a combination of both, depending on driving conditions and power demands. Many parallel HEVs offer plug-in capability, allowing users to charge the battery pack from an external power source, further reducing reliance on the ICE and improving overall efficiency.

III. RISK SOURCES

In this section, the risk sources associated with work activities involving EVs are discussed. In this paper, the risk in the

scenario where an EV is interconnected to a charging station is not considered [18].

A. Electric shock

An electric shock is defined as the “physiological effect resulting from an electric current passing through a human body or livestock” [19]. The effects are more severe by increasing the current and the exposure time.

An electric shock can occur in case of direct and indirect contact. In the first one, the person touches one or more live parts. In the second, the electric contact of human beings is established with exposed conductive parts that have become live under fault conditions [19]. In normal operation mode, manufacturers of EVs have adopted measures to guarantee protection against direct and indirect contacts. In working on EVs, or after a crash, these measures could be removed or damaged. Moreover, where a BP is installed and therefore only some part of the circuit can be disconnected, specific analysis and precautions should be adopted.

If a direct contact occurs, the current flowing through the human body can have different paths and amplitude, based on the involved number of poles and parts of the body. Fig. 2 depicts the most frequent and significant direct contacts. Fig. 2-a represents the contact between a person (one hand) and a live part of the electrical wiring. Both the person and the vehicle are usually in contact with the soil through high impedance. In an undamaged vehicle, the current flows through the human body impedance (R_B), the shoe impedance (R_S), the natural resistance of the human body to earth (R_{BE}), the the natural resistance of the tire to earth (R_{TE}), the tire impedance (R_T), and the stray capacitance of the electrical wiring (C_{CE}). The stray capacitance plays a crucial role when the negative terminal of the DC-source is not interconnected with the chassis, closing the circuit. In this scenario, since the battery is a DC voltage source, and a capacitance is enclosed in the loop, the current that flows through a person’s body is a transient nature. However, as highlighted in the IEC 60479-2, even unidirectional single impulse currents of short duration can pose a serious hazard [20]. The primary determinant for the onset of ventricular fibrillation in response to various types of unidirectional impulse currents is the magnitude of the $I \cdot t$ or $I^2 \cdot t$ parameter [20]. In a damaged vehicle, such as one involved in a collision, certain impedance elements may become short-circuited, potentially increasing current magnitude. Similarly, impedance elements may become short-circuited when the vehicle under repair is not resting on its wheels but lifted and supported by metal stands. To mitigate the risk to human safety, one practical measure would be to have the person stand on an insulating mat. This would effectively increase the impedance between the person and ground, thereby reducing the magnitude of the current shown in Fig. 2-a in all circumstances. Fig. 2-b shows the contact between the person (through two metallic tools) and both the poles of the electrical wiring. In this case, the current flows between the two hands of the worker; in this case, the human body resistance (R'_B) corresponds to the left-hand to right-hand path. Considering the contact analyzed in Fig. 2-a as a

reference, the impedance of the current path is lower causing a more dangerous scenario. The eventual interconnection of the negative pole of the BP with the metallic chassis of the EV impacts the probability of having this event, since in this case, the probability of having a contact is higher.

Notably, the traction batteries in fully electric vehicles typically exhibit a higher rated voltage than those found in hybrid vehicles, thereby posing a greater electrical shock hazard.

The placement of dangerous live parts can be identified thanks to the safety specifications provided by the standard ISO 6469-3, which is usually adopted by the manufacturers [6]. The standard classifies the on-board electrical circuits considering their maximum working voltage, as reported in Table I. ISO 6469-3 specifies that the symbol ISO 7010-W012 shown in Fig. 3 shall be visible on protective barriers and enclosures which, when removed, expose hazardous live parts of voltage class B electrical circuits. The insulation surrounding cables and harnesses used in voltage class B2 electrical circuits, when not contained within protective enclosures or shielded by protective barriers, must be visibly distinguished by an orange color marking. For voltage class B1 cables and harnesses, they should be identified by a two-color combination of orange and purple, or solely by an orange color marking.

B. Arc flash

The arch flash is defined as a “self-maintained gas conduction for which most of the charge carriers are electrons supplied by primary electron emission” [21]. The Standard IEC 60050-651 specifies in the notes that during live work, the electric arc is generated by gas ionization arising from an unintentional electrical conducting connection or electric breakdown between live parts or a live part and the earth path of an electrical installation or an electric device [21].

A European standard to properly manage the arc flash risk is still missing. EN 50110-1 simply mentions in Annex B.6.3 some examples of guidelines for assessing the arc flash hazard, such as the American NFPA 70E and the German DGUV 203-077 [9], [22]. Even if the approaches are different, both the Standards consider the probability of occurrence of an arc flash and its electrical properties to identify dangerous situations and choose the right Personal Protective Equipment (PPE).

Usually, manufacturers cover the live parts with insulation or enclosures, reducing the probability of accidental short circuits that can cause arc flashes. Moreover, protection against

TABLE I
VOLTAGE CLASSES ACCORDING TO ISO 6469-3 [6]

Class	Maximum working voltage [V]	
	DC	AC
A	$0 < U \leq 60$	$0 < U \leq 30$
B	$60 < U \leq 1500$	$30 < U \leq 1000$
B1	$60 < U \leq 75$	$30 < U \leq 50$
B2	$75 < U \leq 1500$	$50 < U \leq 1000$

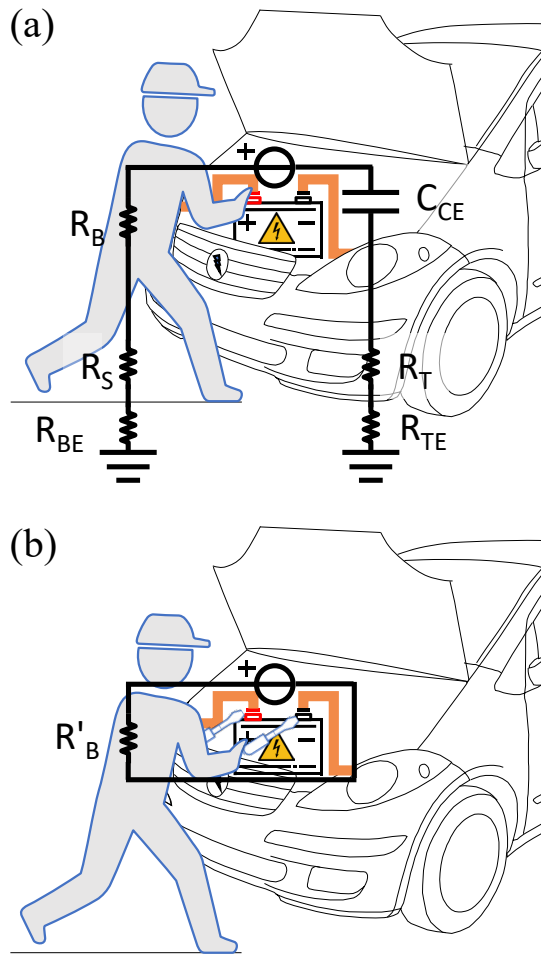

Fig. 2. Direct contacts: In (a), the individual is in contact with a single pole of the DC source. In (b), the individual simultaneously contacts both poles of the battery pack. In both, the over-imposed black-highlighted paths represent the equivalent circuits.

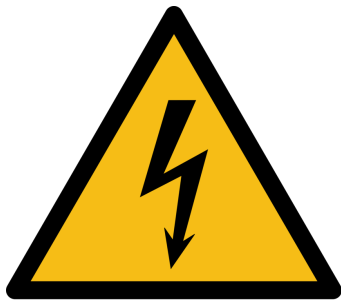

Fig. 3. Symbol ISO 7010-W012 [6]. It identifies Class B electric components.

over-currents (e.g. fuses) reduces the time of the arc flash event, with a great reduction of the incident energy [9]. Typically, a fuse is installed downstream of the terminals of the BP, and sometimes, a fuse could be connected in series to each cell of the BP. If the probability of having an arc flash is not negligible, and its energy could injure workers, PPEs shall be worn. It is important to highlight that the traction batteries in fully electric vehicles generally have a higher capacity compared to those in hybrid vehicles, and therefore the consequences of an arc flash could be more severe.

C. Fire and explosion on battery packs

Thermal Runaway (TR) in batteries is defined as the “Self-heating of an electrochemical system in an uncontrollable fashion” [23]. TR can occur within a battery cell when increased temperature initiates a series of exothermic reactions, leading to a further rise in temperature and the onset of more harmful reactions. This elevated temperature can result from a gradual buildup of heat that is not effectively dissipated promptly or from sudden, externally induced reactions within a brief time frame [24]. The TR can spread from a cell to the entire BP, as in a chain effect, producing fires and explosions (this is commonly known as cell-to-cell propagation, or propagating thermal runaway). It is typically caused by internal short-circuit, which can be caused by battery manufacturing defects, as well as mechanical, electrical, and thermal abuses [25]–[27].

D. Chemical burns and poisoning

Maintenance of EVs introduces unique chemical hazards that technicians must manage. In particular, lithium-ion batteries contain flammable electrolytes, such as lithium hexafluorophosphate (LiPF_6) in organic solvents, which pose fire and explosion hazards if mishandled or damaged [28]. Additionally, exposure to electrolyte components, including lithium salts and organic solvents, can cause skin irritation, respiratory problems, or other health issues.

IV. WORK ON ELECTRIC VEHICLES - STATE OF THE ART

The works on electric vehicles can be classified into two categories:

- 1) Shop work, which is necessary to maintain the functioning of the vehicle over time. During these activities, the people exposed to the risks are the workshop employers. As already discussed, there is no dedicated International, American or European Standards specifically focused on these activities. Currently, in Europe, the reference standard is the EN 50110, which provides recommendations to safely carry out works on electrical installations [10]. In the scope of the standard, it is specified that this document has not been specifically developed for vehicles, but the principles of this document could also be applied to these systems if there are no other rules or procedures. In subsection IV-A, the main principles of the EN 50110 are presented, as they can inspire specific guidelines for work on electrical vehicles.
- 2) emergency works, which are after a crash carried out by firefighters to secure the vehicles. In this case, the people exposed to the risk are the firefighters themselves, the driver and the passengers of the vehicle, and the citizens in the proximity of the accident site. Even if the aims are different, some analogies between the two work types can be found. For example, in both cases, people are exposed to the same risk sources (presented in section III), and the risks depend on the status of the vehicle. In section IV-B, an analysis of the guidelines provided by the American Fire Protection Research Foundation is presented [7]. The aim is to identify the measures that can increase safety for workers, also in non-emergency scenarios.

A. EN 50110 principles: operation of electrical installations

The EN 50110 describes the requirements for general work on or close to an electrical installation. Its main principles can be summarized as follows.

- The works can be classified into three categories: works in Live Working Zone (LWZ), which is the space around live parts in which the insulation level to prevent electrical danger is not assured when reaching into or entering it without protective measures; works within a Vicinity Zone (VZ), which is a limited space outside the LWZ; works outside of the VZ, where the minimum prerequisite the controls which are commonly set out for areas with unrestricted access concerning electrical hazards shall be observed.
- The LWZ and VZ are delimited by the distances D_L and D_V , respectively. These borders are a function of the rated voltage. For AC and DC systems characterized by a rated voltage lower than 3 kV, which is a voltage close to the maximum voltage classes reported in Table I for EVs, $D_L = 60$ mm and $D_V = 1120$ mm.
- The procedures for works in the LWZ are two:
 - 1) Dead work, which requires:
 - a) The disconnection of the part of the electrical installation on which work is to be carried out.
 - b) To secure against re-connection, locking the operating mechanism of switches, or doing equivalent preventative actions.
 - c) To verify the absence of operating voltage, using voltage detectors that have been previously tested.
 - d) Earthing and short-circuiting all parts that are to be worked on. This is always required for systems characterized by a rated voltage >1 kV in AC or 1.5 kV in DC. For the others, it is required if there is the risk that the electrical installation is being made live (e.g. by a battery storage).
 - e) To adopt protection against adjacent live parts.

This procedure shall be adopted if technically feasible.
 - 2) Live work, for which collective or personal protective equipment is required. In case of maintenance on EVs, workers shall use insulating gloves and possibly arm sleeves, insulated and insulating hand tools.
 - The procedures for work within the VZ require the adoption of safety measures so that live parts cannot be touched or the LWZ cannot be reached. For example, an effective measure is the installation of a screen, barrier, enclosure, or insulating covering. The same approach is proposed for working outside the VZ, after a risk assessment.
 - The personnel shall have practical and theoretical skills to properly identify and manage dangerous situations.

B. Emergency scenarios that involve EVs

The best practices proposed by the American Fire Protection Research Foundation can be summarized with the following steps [7]:

- 1) Identifying the presence of an EV, recognizing labels of the brand and model. If the electrical wiring is visible, the presence of symbols associated with an electric risk (e.g. the one reported in Fig. 3 and the “orange cables” described in subsection III-A) can also be useful for this activity, as suggested by the Italian Guidelines [8].
- 2) Immobilizing the vehicle, placing chocks to the front and rear of one of the wheels.
- 3) Disabling the vehicle, switching off and disconnecting all the power sources (such as the high voltage BP or the battery that often powers the auxiliary circuits). If the vehicle can be turned on/off by a proximity key, after the power-off, place the key beyond the range of the vehicle. To prevent the vehicle from powering up, after the power-off, the American guidelines require the severing of the auxiliary battery’s negative ground cable and, eventually, the pulling of fuses to disable the high-voltage system. Only if the previous action cannot be exploited, the main disconnect should be removed or switched off.

In case of fire, a large and sustained volume of water is required [7], [8].

V. PROPOSED RECOMMENDATIONS TO WORK ON EVS

The proposed suggestions can be grouped into two categories: the first ones are related to the properties of the workshop; the second ones are related to the organization of the work and operational procedures.

A. Workshop set-up

The following are the actions required to properly set up the workshop on which the activity under consideration will be carried out, considering also the recommendations provided by the EN 50191 [29]:

- While performing the activities, cordon off the area using barriers or obstacles. Barriers can be tapes, ropes, chains, or bars that must be fixed between 1000 mm and 1400 mm away from the floor. The minimum distance from the ground must not be less than 800 mm [29].
- Hang warning signs to indicate the presence of live parts.
- Ensure that the room is sufficiently illuminated even following an interruption of the power supply.
- Adopt measures to mitigate the risk of fire and explosion. For example, evaluate the adequacy of the ventilation in the room to avoid over-temperatures and explosive atmospheres.
- Adopt measures to prevent a fire in the room from propagating to other parts of the buildings.
- Design escape routes to guarantee an effective and timely evacuation.

B. Organization of the work and operational procedures

Considering the EV properties (section II), the risk sources (section III), and the suggestions provided (section IV), the following recommendations to properly manage the risk associated with working on EVs are presented:

- Identify the risk sources for the specific activity under analysis.
- Instruct and train the personnel, who shall have theoretical and practical skills before carrying out the work. The level of ability should be confirmed by a live working certificate, delivered by the employer.
- The role of each person during the work shall be clear to everybody, and specified in writing, to avoid misunderstanding and for a clear acceptance of responsibility.
- For all the complex works and the most frequent ones, written instructions shall be made available for each model of EV, so that they can be consulted by the involved operators before starting activities.
- Identify BP over temperatures using thermal sensors (such as a thermal camera). If a temperature greater than the environmental one is detected, wait until the BP has completely cooled down.
- If possible, disconnect all the power sources (such as the high voltage BP or the auxiliary battery), following the dead work procedure provided by [10]. This can be carried out effectively for all the works where it is not required that the EV could be powered on.
- In certain circumstances, such as the identification of a fault, it is not possible to disconnect the power sources. In this case, the live working procedure shall be adopted. Considering the typical rated voltage of the EV wiring reported in Table I, Class 0 insulating electrical gloves, which are designed to protect against 1kV in AC and 1.5 kV in DC systems, shall be used. Class 00 gloves (rated at 500 V_{AC} and 750 V_{DC}) can be used on battery systems known to be lower than 750 V_{DC}. It is good to remember that dielectric gloves are often not cut-resistant. In this case, an overglove offering mechanical protection is necessary. Moreover, insulating or isolated tools shall be used to increase the protection against both electric shock and arc flash. For the other risks, a dedicated assessment shall be evaluated to identify the need for PPE, and their properties.

VI. CASE STUDY

As a case study, the maintenance operation on the BP of a full electric bus operating in the city of Turin, Italy, is presented. The electric bus under evaluation is equipped with several Lithium-cells connected in series. If a cell breaks down, the Battery Management System (BMS) stops the bus. To restore the full functionality of the vehicle, the failed cell shall be replaced. In this section, the risk evaluation and management of this activity, to be carried out in the workshop, is presented.

A. Technical details

Two lithium “Iron Phosphate” Battery Packs (BPs) (LiFePO₄) are connected in series. Each BP is formed by 4

modules interconnected in series, which in turn are formed by 52 cells connected in series.

A BP is characterized by a rated voltage of 666 V and a rated capacity of 133 kWh. The main characteristics of the cells are reported in Table II.

B. Work procedure

Workers have to disassemble the BP to replace the faulted cells.

Firstly, the BP case is extracted from the vehicle and placed over a support base, as shown in Fig. 4-a. Taking the front panel apart, the components visible in Fig. 4-b become accessible. For this analysis, the main ones are the contactor, the safety fuse, and the power connectors. The BMS of the vehicle is formed by a master control unit (Fig. 4-b) and 4 slave Battery Control Units (BCU), visible on the upper part of the BP (Fig. 4-a).

Once the power and signal cables in Fig. 4-b have been disconnected, the metal panel can be removed as shown in Fig. 4-c. Insulating purple covers provide extra protection to the workers, avoiding undesired contact with the cell terminals.

Then, the BMs shall be extracted from the metallic framework. Fig. 4-d shows the cells, held together by insulating clamps. Behind the insulating purple covers, the terminals of the individual cells are placed. The positive terminals are colored red and the negative ones are black. The cells are positioned in such a way as to make their connection in series easy. Each cell is also protected internally from the risks of short circuits by a special fast-acting fuse, although the manufacturer emphasizes that a short circuit current just below the fuse’s calibration current can lead to an increase in cell temperature and venting.

Finally, the workers can disconnect the faulted cell and replace it.

C. Risk evaluation and management

The electrical risk is associated with the occurrence of two dangerous events, namely electric shock and arc flash.

The Standard EN 50110-1 defines three possible work procedures: dead working, live working, and working in the vicinity of live parts [10]. When technically possible, in order to reduce the risk to workers, it is always necessary to de-energize the circuit. In the specific case analyzed, the BP is a source of electrical energy that cannot be turned off. For this reason, the replacement of a failed cell necessarily

TABLE II
CHARACTERISTICS OF THE LiFePO₄ CELLS

Quantity	Unit of measurement	Value
Capacity	[Ah]	200.00
Rated voltage	[V]	3.20
Maximum voltage	[V]	3.65
Minimum voltage	[V]	2.90
Weight	[kg]	5.60
Volume	[dm ³]	3.97
Power density	[W/dm ³]	1612.09
Energy density	[Wh/dm ³]	161.21

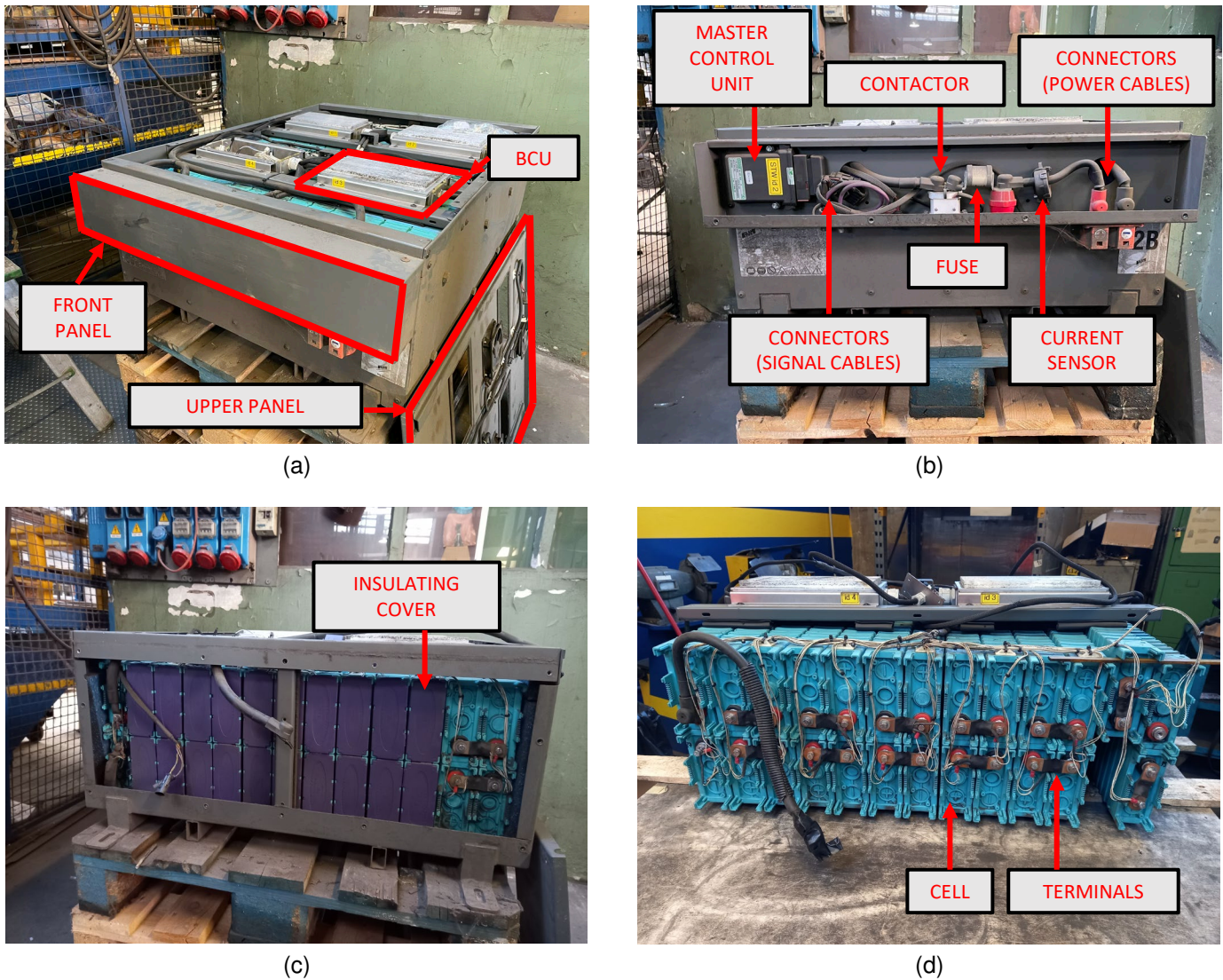

Fig. 4. Case of the battery pack: (a) - just extracted from the vehicle; (b) - front view, after removing the front panel; (c) - front view, after disconnecting the signal and power cables and removing the metallic panel; (d) - interconnected cells managed by the same BCU, extracted from the metallic framework and after removing the purple insulating covers.

will have to be classified as “live working” [10]. Given the characteristics of the operations to be performed, the live working methodology will be “insulating glove working” [10].

Considering electric shocks, in DC systems, the maximum contact voltage that can be maintained for an indefinite time is typically 120 V [10]. The rated voltage of the module is 166 V, so it is necessary to identify effective protection measures against electric shock. For the selected work methodology and the rated voltage of the module, the workers shall use insulating gloves of at least class 00, which are designed for systems with a rated voltage up to 750 V DC [10], [30]. Gloves shall guarantee adequate resistance against mechanical punctures, abrasion, cutting, and tear. A further protection is achieved by using insulated tools, which also decrease the likelihood of an electric arc [31].

Gloves and insulating tools protect workers in the case of simultaneous contact with both poles of the circuit (hand-to-hand contact), as discussed in subsection III-A. In fact, if the

battery pack is placed on a table with an insulated surface, its potential remains floating with reference to earth. If no class I appliances (whose case is connected to the earthing system) are placed in the work area, and there are no other electrical sources, a worker who touches a pole of the circuit (either positive or negative) and who is on a floor insulated from the earth will not have a dangerous current flow through them.

In regard to arc flash, each cell is equipped with a fast-acting fuse that mitigates the arc energy. Moreover, the layout of the BP guarantees that the voltage between metallic terminals of cells close to each other is below 50 V, reducing the probability of having high-energy arc flash events. However, since the fuse rating data is unknown and theoretically an arc flash between the first and last cells interconnected in series is feasible, these aspects are not considered in the risk assessment. To reduce the risk for workers, technical and organizational measures to reduce the probability of creating involuntary short circuits and consequently tripping

an electric arc shall be adopted. To avoid accidental short circuits, in addition to the use of insulated tools, the accessible live parts should be insulated at all stages of the operation. The terminals of the positive and negative cables shown in Fig. 4 should be isolated one at a time, to avoid simultaneous contact with both poles of the circuit or the triggering of an electric arc. Their insulation can be achieved by completely covering the conductive parts with insulating tape, although this procedure depends on the skill of the worker. If the work is not carried out carefully, conductive parts could remain uncovered. Alternatively, a safer method is to fix the end of the cables to a terminal block located inside a plastic casing classified as Class II [32]. This solution, compared to the simple use of insulating tape, is mechanically more robust and also guarantees the effectiveness of the insulation regardless of the operator's care.

If the cable terminals are well insulated, only the strictly necessary insulating purple covers are removed, and only insulating tools are used, then the ignition of an electric arc is not considered probable.

EN 50110-1 requires that "Live working procedures shall only be carried out after having suppressed fire and explosion risks" [10]. In electrical work performed on a circuit powered by a BP, and particularly by lithium batteries, eliminating the risk of fire or explosion is not technically possible to date. However, before performing the task, it is necessary to verify that the probability of a fire or explosion occurring is negligible. For this reason, during the disassembling procedure described in subsection VI-B and Fig. 4, a visual inspection should be conducted to locate damaged cells and, with the help of a thermal imaging camera, identify hot spots that could lead to the uncontrolled phenomenon of "thermal runaway". If the outcome of this inspection does not give sufficient assurance of the low probability of the occurrence of fire and/or explosion, it is necessary to adopt additional safety measures.

All operators performing the activity shall be properly instructed and with enough experience. As required by the Standard, they must also be qualified to carry out live work. During the execution of the activity, the work area must be delimited by the use of barriers or obstacles [32], since the presence of unskilled or not-instructed persons cannot be excluded.

VII. CONCLUSION

This paper underscores the significant transition towards sustainable transportation solutions witnessed in recent years, exemplified by the growing adoption of Electric Vehicles (EVs). However, it is crucial to acknowledge that EVs, like any automotive technology, are not without their challenges. Safety concerns, particularly regarding the unique characteristics of electric propulsion systems and high-voltage components, necessitate proper risk management strategies and adherence to safety standards. This includes the development of specific regulations addressing electrical works on vehicles, which are currently lacking at the International or European level.

The paper identifies various risk sources associated with working on EVs, such as electric shock, arc flash, fire, explosion on battery packs, and chemical burns and poisoning.

To address these risks, the paper proposes suggestions for maintenance works on EVs, encompassing workshop set-up considerations and organizational procedures. These recommendations emphasize the importance of proper training for personnel, identification of risk sources, and adoption of appropriate Personal Protective Equipment (PPE) and operational procedures. A case study is presented and discussed, to provide a practical example of risk assessment and management procedure. In particular, the selection of PPE, the organization of the work location, and the operating procedures that shall be implemented are discussed. Overall, the paper provides valuable insights into mitigating risks and ensuring the safe operation of EVs, contributing to the ongoing discourse on sustainable mobility solutions.

ACKNOWLEDGMENTS

We would like to thank "Gruppo Torinese Trasporti" (GTT) for sharing information and discussing the case study, and in particular Marianna Costa, Luigi Degni, Salvatore Gaudiello, and Pietro Urso.

REFERENCES

- [1] T. Yuvaraj, K. R. Devabalaji, J. A. Kumar, S. B. Thanikanti, and N. I. Nwulu, "A comprehensive review and analysis of the allocation of electric vehicle charging stations in distribution networks," *IEEE Access*, vol. 12, pp. 5404–5461, 2024.
- [2] *COMMUNICATION FROM THE COMMISSION TO THE EUROPEAN PARLIAMENT, THE COUNCIL, THE EUROPEAN ECONOMIC AND SOCIAL COMMITTEE AND THE COMMITTEE OF THE REGIONS - Sustainable and Smart Mobility Strategy – putting European transport on track for the future*. European Commission, 2020.
- [3] L. Raslavičius, B. Azzopardi, A. Keršys, M. Starevičius, Ž. Bazaras, and R. Makaras, "Electric vehicles challenges and opportunities: Lithuanian review," *Renewable and Sustainable Energy Reviews*, vol. 42, pp. 786–800, 2015.
- [4] *Electrically propelled road vehicles — Safety specifications. Part 1: On-board rechargeable energy storage system (RESS)*. ISO 6469-1, 2009.
- [5] *Electrically propelled road vehicles — Safety specifications. Part 2: Vehicle operational safety*. ISO 6469-2, 2022.
- [6] *Electrically propelled road vehicles — Safety specifications. Part 3: Electrical safety*. ISO 6469-3, 2021.
- [7] O. Park, "Best practices for emergency response to incidents involving electric vehicles battery hazards: A report on full-scale testing results," *The Fire Protection Research Foundation, Quincy, MA, Report*, no. 1205174.000, p. F0F0, 2013.
- [8] *Draft: Linee Guida per incidenti che coinvolgono auto elettriche-ibride*. Corpo Nazionale dei Vigili del Fuoco, 2019.
- [9] *Standard for Electrical Safety in the Workplace*. NFPA 70 E, 2024.
- [10] *Operation of electrical installations - General requirements*. EN 50110-1, 2024.
- [11] P. Colella and E. Pons, "Electric vehicles maintenance: Recommendations for a safe work," in *2024 IEEE International Conference on Environment and Electrical Engineering and 2024 IEEE Industrial and Commercial Power Systems Europe (EEEIC/I&CPS Europe)*. IEEE, 2024, pp. 1–6.
- [12] D. H. Lim and S. C. Kim, "Thermal performance of oil spray cooling system for in-wheel motor in electric vehicles," *Applied Thermal Engineering*, vol. 63, no. 2, pp. 577–587, 2014.
- [13] K. Sedef, A. Maheri, A. Daadbin, and M. Yilmaz, "A comparative study of the performance of dc permanent magnet and ac induction motors in urban electric cars," in *2012 2nd International Symposium On Environment Friendly Energies And Applications*, 2012, pp. 100–105.
- [14] M. Zeraoulia, M. E. H. Benbouzid, and D. Diallo, "Electric motor drive selection issues for hev propulsion systems: A comparative study," *IEEE Transactions on Vehicular Technology*, vol. 55, no. 6, pp. 1756–1764, 2006.
- [15] W. Cao, J. Zhang, and H. Li, "Batteries with high theoretical energy densities," *Energy Storage Materials*, vol. 26, pp. 46–55, 2020.

- [16] P. Sun, R. Bisschop, H. Niu, and X. Huang, "A review of battery fires in electric vehicles," *Fire technology*, vol. 56, pp. 1361–1410, 2020.
- [17] R. Bisschop, O. Willstrand, and M. Rosengren, "Handling lithium-ion batteries in electric vehicles: preventing and recovering from hazardous events," *Fire technology*, vol. 56, pp. 2671–2694, 2020.
- [18] F. Freschi, M. Mitolo, and R. Tommasini, "Electrical safety of plug-in electric vehicles: Shielding the public from shock," *IEEE Industry Applications Magazine*, vol. 24, no. 3, pp. 58–63, 2018.
- [19] *International Electrotechnical Vocabulary (IEV) - Part 195: Earthing and protection against electric shock*. CEI EN 60050-195, 2021.
- [20] *Effects of current on human beings and livestock. Special aspects*. CEI EN 60479-2, 05 2019.
- [21] *International Electrotechnical Vocabulary (IEV) - Part 651: Live working*. CEI EN 60050-651, 2014.
- [22] *Thermal hazards due to electric fault arcing*. DGUV Information 203-077, 2021.
- [23] *Standard for the Installation of Stationary Energy Storage Systems*. NFPA 855, 2023.
- [24] J. Zhang, L. Zhang, F. Sun, and Z. Wang, "An overview on thermal safety issues of lithium-ion batteries for electric vehicle application," *Ieee Access*, vol. 6, pp. 23 848–23 863, 2018.
- [25] W. Gao, X. Li, M. Ma, Y. Fu, J. Jiang, and C. Mi, "Case study of an electric vehicle battery thermal runaway and online internal short-circuit detection," *IEEE Transactions on Power Electronics*, vol. 36, no. 3, pp. 2452–2455, 2020.
- [26] X. Feng, M. Ouyang, X. Liu, L. Lu, Y. Xia, and X. He, "Thermal runaway mechanism of lithium ion battery for electric vehicles: A review," *Energy storage materials*, vol. 10, pp. 246–267, 2018.
- [27] S. Chavan, B. Venkateswarlu, R. Prabakaran, M. Salman, S. W. Joo, G. S. Choi, and S. C. Kim, "Thermal runaway and mitigation strategies for electric vehicle lithium-ion batteries using battery cooling approach: A review of the current status and challenges," *Journal of Energy Storage*, vol. 72, p. 108569, 2023.
- [28] F. Larsson, P. Andersson, P. Blomqvist, and B.-E. Mellander, "Toxic fluoride gas emissions from lithium-ion battery fires," *Scientific reports*, vol. 7, no. 1, p. 10018, 2017.
- [29] *Erection and operation of electrical test equipment*. EN 50191, 10 2010.
- [30] *Live working - Gloves of insulating material*. Standard EN 60903, 2005.
- [31] *Lavori su impianti elettrici*. Norma CEI 11-27, 2021.
- [32] *Low-voltage electrical installations - Part 4-41: Protection for safety - Protection Against Electric Shock*. IEC 60364-4-41, 2005.

VIII. BIOGRAPHY SECTION



Pietro Colella (Member, IEEE) received the M.Sc. and Ph.D. degrees in Electrical Engineering from Politecnico di Torino, Turin, Italy, in 2012 and 2016, respectively. He is currently an Assistant Professor at Politecnico di Torino, where he teaches courses in electrical installations. He serves as Principal Investigator for several industrial and publicly funded research projects. His research interests include power systems, electricity markets, traction electrification, clustering and artificial intelligence algorithms applied to power systems, and electrical safety. Dr. Colella is also a member of AEIT—the Italian Association of Electrical, Electronics, Automation, Information and Communication Technology.



Enrico Pons (Senior Member, IEEE) received the master's degree in electrical engineering and the Ph.D. degree in industrial safety and risk analysis from Politecnico di Torino, Turin, Italy, in 2004 and 2008, respectively. He is currently an Associate Professor with Politecnico di Torino, where he teaches electrical installations. His research interests include complexity in energy systems, power systems security, complex network methodologies for the analysis of power systems vulnerability, real-time simulation of power systems, integration of renewable generation in distribution networks, smart metering, traction electrification systems, and electrical safety.