

Optimisation of green hydrogen production for hard-to-abate industries: An Italian case study considering national incentives

Original

Optimisation of green hydrogen production for hard-to-abate industries: An Italian case study considering national incentives / Stolte, M., Minuto, F.D., Perol, A., Bindi, M., Lanzini, A.. - In: INTERNATIONAL JOURNAL OF HYDROGEN ENERGY. - ISSN 0360-3199. - ELETTRONICO. - 141:(2025), pp. 1294-1304. [10.1016/j.ijhydene.2025.03.008]

Availability:

This version is available at: 11583/3002199 since: 2025-07-29T09:10:53Z

Publisher:

Elsevier

Published

DOI:10.1016/j.ijhydene.2025.03.008

Terms of use:



This article is made available under terms and conditions as specified in the corresponding bibliographic description in the repository

Publisher copyright

(Article begins on next page)



Optimisation of green hydrogen production for hard-to-abate industries: An Italian case study considering national incentives

Marcel Stolte^{a,b,*} , Francesco Demetrio Minuto^{a,b} , Alessandro Perol^c, Massimiliano Bindi^c, Andrea Lanzini^{a,b}

^a Department of Energy, Politecnico di Torino, Corso Duca degli Abruzzi 24, 10129, Torino, Italy

^b Energy Center Lab, Politecnico di Torino, Via Paolo Borsellino 38/16, 10138, Torino, Italy

^c Edison S.p.A., Via Paolo Borsellino 38/16, 10138, Torino, Italy

ARTICLE INFO

Handling Editor: Ibrahim Dincer

Keywords:

Green hydrogen
Energy storage
Hard-to-abate industry
Industry decarbonisation
Power-to-hydrogen
Particle Swarm Optimisation

ABSTRACT

Green hydrogen has emerged as a promising energy vector for the decarbonisation of heavy industry. The EU and national governments have recently introduced incentives to address the high costs of green hydrogen production and accelerate the economic development of hydrogen. This study investigates the local production of green hydrogen to decarbonise the high-temperature process heat demand of a heavy industry located in Italy. The hydrogen generation is powered by PV electricity and from the electric grid. We have optimised the sizes of the energy system components, including battery storage and hydrogen tanks. The Levelised Cost of Hydrogen (LCOH) was found to be 7.7 EUR/kg in the unincentivised base scenario, but this amount significantly reduced to 3.3 EUR/kg when incentives on hydrogen production in abandoned industrial areas were considered. Thanks to such incentives, the greenhouse gas emissions decreased by as much as 85 %, with respect to the non-incentivised base case. Our results show that the effect of the incentives on the design and economics of the system is comparable with the expected reductions in equipment costs over the next decade. Importantly, our findings reveal a linear relationship between Capital Costs and LCOH, thereby enabling precise cost estimations to be made for the considered location without any further simulations. A side effect of the size optimisation in the presence of incentives is an increase of the plant footprint. However, the limited availability of land could lead to non-optimal configurations with important impacts on emission intensity and LCOH.

1. Introduction

The industrial sector is a major contributor to greenhouse gas emissions, accounting for 25 % of the global CO₂ emissions of the energy system [1]. Unlike other sectors where direct electrification can be used to decarbonise many applications, industry has to face challenges concerning the electrification of all the processes. However, green hydrogen represents a promising alternative for some of these processes as it can be used to replace a traditional natural gas-based supply, where direct electrification is challenging. Moreover, such a transition could also mitigate the need for expensive equipment and infrastructure modifications [2]. Nevertheless, the high cost of green hydrogen production remains a significant barrier to its broader implementation [3,4].

Policy measures are essential to address this challenge and stimulate both production and demand. Governments throughout the world have

begun to roll out green hydrogen strategies [5]. The United States has implemented the Inflation Reduction Act (IRA), which provides substantial subsidies, including production tax credits, to encourage green hydrogen production and local industry [3,6,7]. Similarly, Japan has introduced the “Basic Hydrogen Strategy,” which encompasses policies and initiatives aimed at establishing a hydrogen economy [3,7]. Australia has also started to implement a hydrogen strategy, which includes tax credits, and has the goal of becoming a major exporter of hydrogen [8].

In Europe, the primary regulatory framework is established, by the European Union, through Renewable Energy Directive II and two delegated acts [9]. Given the energy-intensive nature of hydrogen production, achieving significant reductions in greenhouse gas emissions hinges on the need to ensure that the used electricity comes from renewable sources. Consequently, the European Union has set certain

This article is part of a special issue entitled: WHEC2024(Verde) published in International Journal of Hydrogen Energy.

* Corresponding author. Department of Energy, Politecnico di Torino, Corso Duca degli Abruzzi 24, 10129, Torino, Italy.

E-mail address: marcel.stolte@polito.it (M. Stolte).

<https://doi.org/10.1016/j.ijhydene.2025.03.008>

Received 11 July 2024; Received in revised form 27 February 2025; Accepted 1 March 2025

Available online 9 March 2025

0360-3199/© 2025 The Authors. Published by Elsevier Ltd on behalf of Hydrogen Energy Publications LLC. This is an open access article under the CC BY-NC-ND license (<http://creativecommons.org/licenses/by-nc-nd/4.0/>).

requirements for green hydrogen production. Indeed, any incentives for green hydrogen must adhere to regulatory principles, such as temporal and geographic correlation and additionality [10].

Support mechanisms for green hydrogen are available at the European, the national and the regional levels. European Hydrogen Bank auctions are an example of a financing scheme that has provided incentives on a EUR/kg_{H₂} basis. The first round of the auction allocated a total of 720 million EUR to 7 projects. Out of 132 bids, the auction showed a great deal of interest in industries with expected average off-taker prices of 5.67 EUR/kg, where the clearing price was as low as 0.48 EUR/kg, that is, well below the ceiling price of 4.5 EUR/kg [11]. The locations of the winning projects are characterised by a high renewable potential, for example, the Iberian Peninsula, which has ample solar and wind resources, and Nordic countries, which have inexpensive electricity from wind and/or hydroelectric sources. The EU plans to launch a second round of these auctions by the end of 2024, whereby it will assign an additional 1.2 billion EUR [12].

Other support mechanisms include incentives for capital expenditure. An example of such a mechanism is the production of green hydrogen in abandoned industrial areas [13], which fosters decarbonisation for hard-to-abate industries and helps build up a local hydrogen infrastructure. This incentive is in fact included in the Italian scheme for the realisation of hydrogen valleys and has received funding of 450 million EUR. In order to access these incentives, a project must include an electrolyser in the 1–10 MW range and additional renewable energy plants, coherent with the EU's renewable hydrogen regulations [10]. The incentives also cover energy storage costs, provided they constitute less than 50 % of the total cost. Evaluation of the project was based on three criteria: the funding requested per kilogram of hydrogen produced, the proximity of hydrogen use, and the load factor of the electrolyser powered by renewables. From these general regulations, project calls were defined in each Italian region and winners were selected. Overall, more than 50 projects have been awarded incentives across all the Italian regions. For example, in the Piedmont region, three projects, that comprise 6 MW of electrolyser capacity and 9 MW of renewable energy capacity, receive a total of 19 million EUR in funding [14].

1.1. Literature review

Previous literature has extensively characterised the green hydrogen potential in various geographical areas and optimised power-to-hydrogen applications. Schiebahn et al. laid the groundwork with their analysis of Power-to-Gas utilisation in Germany, in which they evaluated the role of hydrogen as a link between different sectors and as an energy storage medium, and assessed different electrolysis technologies [15]. Mingolla et al. analysed 38 European NUTS-2 regions, while focusing on major ammonia plants powered by solar and wind energy to produce hydrogen. They conducted a sensitivity analysis regarding different emission intensity caps and found average LCOH values of 4.1 EUR/kg whenever no emission cap was present, a value that increased significantly for strict emission targets. They also found that the renewable potential of the location had an important effect on the costs and the plant sizing [16]. Masihiy et al. studied green hydrogen production from wind and solar PV in Chile, where hydrogen was delivered by trucks to meet the annual demand. They found LCOH values ranging from as low as 2–4 EUR/kg for frequent hydrogen delivery, and found that these values were influenced by the delivery frequency and by the generation curtailment of the renewable power [17]. Barhoumi et al. examined a hydrogen refuelling station in Tunisia that was powered by a solar PV system, where a Levelised Cost of Hydrogen (LCOH) of 3–5 EUR/kg had been achieved. The study emphasised the significant influence of equipment costs on the LCOH [18].

Furthermore, the cost of the components and technical assumptions are important factors. Weiss and Ikäheimo studied green hydrogen production to achieve a direct reduction in iron production and investigated different sensitivities and their effect on the cost of the system.

They used a detailed process model and found that stricter EU rules on renewable hydrogen production, especially regarding the temporal matching of renewable energy production with electrolysis, increased the demand for energy storage and the system costs [19]. Brandt et al. analysed the same delegated acts of the Renewable Energy Directive. They compared different power purchase scenarios, considering such factors as electricity prices and the availability of renewables, and found that unrestricted grid electricity usage did not necessarily increase the intensity of emissions and could reduce green hydrogen production costs [20].

Analysing studies and projects in comparable southern-European climates and similar political contexts highlighted the challenging economics of green hydrogen production [21]. Some studies assume high hydrogen selling prices [22], or a significant profitability gap was observed. The studies obtaining LCOH below 5 EUR/kg reach these values exclusively in low-CAPEX scenarios [23–25]. For example, a study in Greece compared green hydrogen production costs using dedicated RES plants and grid supply and identified a significant cost gap with blue and grey hydrogen, thereby stressing the need for policies to accelerate the transition to green hydrogen [26]. A publication as part of the TRIERES Hydrogen Valley Project in Greece obtained LCOH of 7–12 EUR/kg and also acknowledged the need for subsidies to mitigate risk and stimulate investment [27]. Various studies [23,24,28] emphasize electrolyser costs as a major driver of hydrogen production expenses.

Janssen et al. investigated off-grid hydrogen production from wind and solar energy across Europe considering different economic assumptions. They found that derisking the investments with dedicated incentives and carbon taxation helped to improve financing options. Currently, the most suitable locations for such systems are characterised by good wind resources, although hybrid systems together with PV may be beneficial in the future [29].

The integration of battery storage in the hydrogen production system to optimize renewable electricity utilisation has also been discussed. Bukar et al. focused on optimising the operational strategy of PV and grid-based hydrogen systems, and they emphasised the role of battery storage in the operation of efficient systems [30]. However, other studies have noted that the current conditions lead to cost increases caused by battery storage when hydrogen is the primary energy demand vector [31,32].

Studies specifically conducted to tackle the Italian context are few. Ciancio, in a case study, investigated the cost of green hydrogen production for a combination of wind and solar energy [33]. Marocco et al. assessed the design of green hydrogen production systems, using an aggregated PV profile for Italy, connected to the grid, and studied the impact on electricity purchase prices [34] and summarized hydrogen initiatives [35]. Given Italy's limited wind resources, compared to other European countries [36], achieving low LCOH values is challenging, which highlights the importance of incentives. Superchi et al. in one of the few studies to deal with green hydrogen incentives in Italy, analysed the sensitivities of CAPEX reductions in electrolysers, battery storage, and hydrogen tanks [37].

1.2. Literature gap and contributions

Despite the growing focus on green hydrogen as a key component in decarbonising the industrial sector, there still remains a significant gap in the literature concerning the impact of green hydrogen incentives. Specifically, there is a lack of comprehensive studies that have examined how these incentives influence the feasibility and adoption of green hydrogen. Incentives impact not only the LCOH and greenhouse gas emissions, but also the sizing of components and, consequently, the land consumption necessary for a plant. To the best of our knowledge, no existing literature has adequately addressed this aspect, and there is therefore a critical need for further investigation. A common limitation that can be found in the literature is the assumption of a constant

demand or even the complete absence of a demand profile, thus the difficulty of always satisfying the industry demand has been neglected.

This article addresses these gaps by presenting a detailed analysis of green hydrogen incentives pertaining to an Italian case study, considering the incentive of green hydrogen production from abandoned industrial areas. It explores the sensitivity of all the component prices, with particular emphasis on the electrolyser, PV and battery storage costs. Furthermore, the simulations we conducted incorporated a real, high-temperature thermal demand profile of a hard-to-abate industry, thereby enhancing the applicability of our findings to real-world decarbonisation efforts. Additionally, the study examines the impact of plant size limitations on the intensity of emissions, plant design, and LCOH values. By setting the results in the context of European incentives and comparing them with fossil fuel-based supply, the article provides valuable insights into the practical challenges and economic considerations of implementing green hydrogen solutions under the current regulatory frameworks. This comparative approach contributes to achieving a more nuanced understanding of the possible pathways to industrial decarbonisation, and highlights both the potentials and the limitations of green hydrogen as a sustainable energy vector.

2. Methodology

Fig. 1 illustrates the hydrogen production system analysed in this study. The system utilises renewable electricity generated by a PV plant to power the electrolyser. Additionally, a Li-ion battery, which is charged exclusively by renewable energy, offers load-shifting capabilities. The system also includes a connection to the electrical grid, which ensures that the demands are met during periods of low renewable energy availability and that any surplus renewable production is absorbed when the hydrogen storage capacity or the electrolysis capacity is exceeded.

The energy system model was developed in Python. Optimisation of the system sizing is achieved through Particle Swarm Optimisation. The PSO algorithm iteratively determines the optimal sizes of the components of the system. The optimisation framework is divided into an outer layer, which adjusts the component sizes, and an inner layer, which simulates system operation and calculates the key performance metrics.

In the outer layer, each particle represents a specific combination of PV peak power, battery AC power, battery storage duration, electrolyser power, and hydrogen storage capacity, which are then evaluated in the inner layer. After each iteration, the outer layer refines the component sizes according to the calculated performance of each particle, with the aim of achieving the lowest levelised cost of hydrogen. This iterative process is repeated, and the component sizes are progressively refined until the optimal solution is obtained.

The inner layer simulates each particle of the system on an hourly basis to calculate the energy flows, hydrogen production, and other performance indicators. The inner layer operates according to a rule-based strategy that manages the operation of the system to maximise

solar PV electricity utilisation and minimise grid withdrawal. The energy flows resulting from an hour-by-hour management of the system are calculated, and the inner layer derives the LCOH for each particle configuration. According to the results of these calculations, the LCOH from each particle is fed back to the outer layer to guide the optimisation in subsequent iterations in order to obtain the best solution.

Further details on the optimisation framework are available in Ref. [38].

2.1. Electricity sources

The renewable electricity inputs were modelled by simulating a dedicated PV plant. PV production data from 2019 were sourced from PV GIS, based on a plant with fixed ground-mounted panels located in central Italy. It was assumed that the plant had a capacity factor of 17%. The lifetime of the PV plant was assumed to be 25 years; the capital costs were set at 800 EUR/kWp and the operational costs at 2% of CAPEX [39, 40]. Power losses in the inverters and cables, dirt on the modules, and degradation were included, and this resulted in an overall system loss of 14% [18]. The specific surface demand was estimated as 2 ha/MWp, which also accounted for any additional components related to the plant [41].

The electrolyser was considered to be connected to the grid in order to ensure coverage of the hydrogen demand during periods of low renewable energy production. The cost of grid electricity was assumed to be 150 EUR/MWh, based on Eurostat data for non-household consumers in the same consumption range for the first half of 2024, excluding recoverable taxes and levies [42]. In this simulation, grid electricity was considered non-renewable to accurately reflect the future regulatory conditions on renewable hydrogen within the European Union. The emission factor used was that of Italy in 2022, that is, 252 gCO_{2eq}/kWh [43].

2.2. Electrolyser

A Proton Exchange Membrane Electrolyser (PEMEL) was chosen for this simulation, due to its advantageous performance under load fluctuations, which is essential to integrate volatile renewable energy sources. An efficiency curve was utilised, using the Kopp [28] and Hofrichter [29] methodologies to represent the operational characteristics of the electrolyser under varying loads. The capital cost of the electrolyser was assumed to be 1100 EUR/kW [44,45], and the annual operational expenditures (OPEX) were set at 3% of the total investment. For spatial requirements, the Joint Research Centre estimates a demand of 120 m²/MW for PEMEL, which was adopted in this study [46]. Given the hourly resolution of the demand profile and the capacity of the PEM electrolyser to handle fast load fluctuations, such dynamic operations as startup and shutdown were neglected in this analysis.

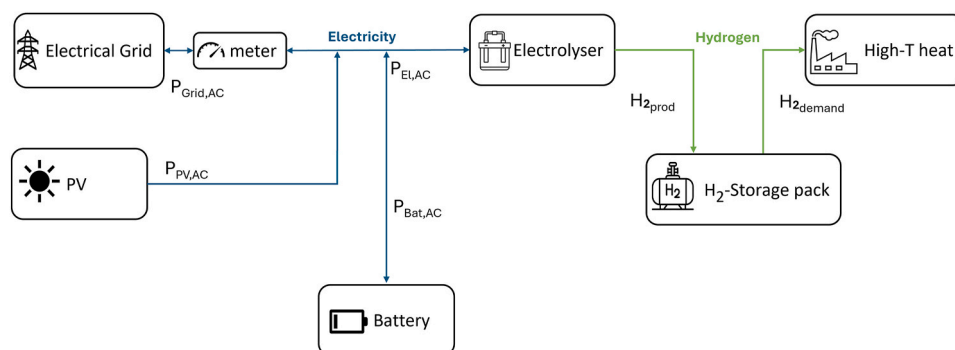

Fig. 1. Overview of the plant scheme.

2.3. Energy storages

Li-ion battery storage was incorporated in the analysis to enable load shifting and to allow the electrolyser to operate with renewable energy during the night. In this way, the battery could reduce its reliance on the grid and the associated CO₂ emissions. Battery storage requires relatively little space, compared to other components, and a footprint of 12 m²/MWh was assumed in this study [47]. The AC-AC roundtrip efficiency of the battery was modelled at 85 % [48,49], and the same efficiency was assumed for both charging and discharging. The operating window was set between 15 % and 95 % of the State of Charge (SOC) to preserve battery life.

The hydrogen tank, located downstream of the electrolyser, was assumed to efficiently absorb any excess renewable energy production, thereby increasing the share of renewable hydrogen and enhancing supply security. We considered a commercial pressure vessel operating over the assumed pressure range to estimate the footprint [50]. We assumed a land occupation of 0.5 m²/kg_{H2} to take into consideration the necessary clearance from other components.

Given the output pressure of 30 bar of the electrolyser, no further hydrogen compression was considered, due to the associated efficiency loss. No hydrogen losses were considered. The state of charge of the tank was regularly updated to be aligned with the hydrogen production and demand, thereby ensuring optimal utilisation.

We considered that the tank could not be discharged below a minimum pressure of 2 bar, and we accounted for pressure losses along the lines and the minimum pressure required by the industrial user. We defined an upper pressure limit of 30 bar. Considering hydrogen densities under different pressures, the SOC was assumed to range between 0.068 and 1. These constraints for both battery storage and the hydrogen tank had to be respected for each timestep:

$$E_{j,nom} \bullet SOC_{j,max} \geq E_j(t) \geq E_{j,nom} \bullet SOC_{j,min} \forall t \{0, \dots, T\} \quad (1)$$

where the energy stored, E , in each of the two storages, j , had to remain between the corresponding upper $SOC_{j,max}$ and lower $SOC_{j,min}$ constraints for each timestep t .

The stored energy in both storages was updated for each timestep, Δt , considering the charge/discharge power $P_{ch,j}$, $P_{dch,j}$ and the charging and discharging efficiencies $\eta_{ch,j}$, $\eta_{dch,j}$

$$E(t + 1)_j = E(t)_j + P_{ch,j} \bullet \eta_{ch,j} \bullet \Delta t - P_{dch,j} / \eta_{dch,j} \bullet \Delta t \quad (2)$$

2.4. User demand profile

The hydrogen demand profile was derived from the high-temperature thermal demand of a hard-to-abate industry located in the same region. This profile was derived from real consumption data and featured a one-year consumption profile with an hourly resolution. The resulting hydrogen demand profile was characterised by a coefficient of variation of 29.6 %, a total yearly demand of 7.5 GW h and an average demand of 850 kW.

2.5. Incentives

The incentives were modelled according to the “hydrogen production in abandoned industrial areas” programme of the Italian Ministry of the Environment and Energy Security described in Chapter 1. These incentives take the form of gross monetary funding, which is aimed at reducing costs. The final project selection was also conducted considering the value of the incentive per kg of green hydrogen produced. We decided to apply a subsidy percentage of the investment costs, distributed over the single components, to model this incentive as accurately as possible. The goal of this policy is solely that of incentivising hydrogen production originating from green electricity sources. As there are strict EU rules regarding additionality and temporal requirement after 2030,

we only considered the incentive pertaining to the share of self-produced renewable electricity used by the electrolyser. Grid electricity was not considered renewable in this calculation, as, in this way, it was possible to reflect the most realistic current assumption regarding the electricity mix and EU regulations [13]. We modelled a theoretical CAPEX incentive, starting from 10 % and going up to 70 % Inc_{theo} , for all the plant components, which we only applied to the share of hydrogen originating from self-produced renewable electricity, el_{green} . The resulting effective incentives Inc_{eff} were calculated according to Equation (3).

$$Inc_{eff} = Inc_{theo} \bullet el_{green} \quad (3)$$

2.6. Evaluation metrics and economic inputs

An overview on the economic assumptions can be found in Table 1.

The solutions were evaluated and optimised on the basis of the LCOH, calculated according to Ref. [56]. In order to compute the LCOH, the cost of the solution had to be evaluated first, starting from the capital recovery factor, CRF , of each plant component, j , considering its lifetime, n , and the discount rate of i .

$$CRF_j = \frac{(1+i)^n \bullet i}{(1+i)^n - 1} \quad (4)$$

The equivalent annual cost (EAC) was calculated for each j -th component according to Eq. (5), where NPC is the present net cost and $O\&M$ are the operation and maintenance costs.

$$EAC = \sum_j^{N_{comp}} CRF_j \bullet NPC_j + O\&M_j \quad (5)$$

The LCOH was calculated by dividing the total annual cost, including the grid electricity cost C_{grid} , by the produced hydrogen P_{H2}

$$LCOH = \frac{EAC + C_{grid}}{\sum_{t=1}^{8760} P_{H2,t}} \quad (6)$$

Grid electricity costs must be included in the LCOH calculation, as the system draws energy from the grid when renewable generation assets or energy storage systems cannot fully meet the user demand. In such cases, grid electricity supplies the remaining demand. Further details on the assumptions regarding grid electricity can be found in 2.1.

The sale of electricity to the grid was not considered part of the LCOH calculation, as selling electricity to the grid goes against the regulations stated in the call to benefit from the incentives on green hydrogen in abandoned industrial areas [13]. The total footprint of the plant was calculated considering the specific land demand, A_{sp} , and the installed capacity, P_{nom} , of each component.

Table 1
Overview of the cost assumptions.

Parameter	Value	Reference
WACC	5%	[51]
PV plant		
CAPEX	800 EUR/kWp	[39]
OPEX	2 %/y of CAPEX	[39]
Lifetime	25 years	[52]
Electrolyser		
CAPEX	1100 EUR/kW	[44]
OPEX	3 %/y of CAPEX	[34]
Lifetime	50000 h	[53]
Battery storage		
CAPEX	EUR/kW = 230*storage duration +249	[48]
OPEX	2.5 % of CAPEX/year	[48]
Lifetime	10 years	[54]
Hydrogen storage		
CAPEX	1100 EUR/kg	[55]
OPEX	2 % of CAPEX/year	[44]

$$A = \sum_j^{N_{comp}} A_{sp,j} \cdot P_{nom,j} \quad (7)$$

The emission intensity of the produced hydrogen, ef_{H2} , was calculated on the basis of the grid emission factor, ef_{grid} , grid withdrawal, P_{grid} , and hydrogen production, P_{H2} , for each timestep t [20].

$$ef_{H2} = \frac{ef_{grid} \cdot \sum_{t=1}^{8760} P_{grid,t}}{\sum_{t=1}^{8760} P_{H2,t}} \quad (8)$$

3. Results

3.1. Base case

Fig. 2 illustrates the optimal sizes of the hydrogen production system, without considering any incentives. The best configuration for this scenario achieves an LCOH of 7.73 EUR/kg. The optimal size of the PV plant is 7.1 MWp, paired with an electrolyser nominal power of 4.0 MW, to satisfy the annual thermal demand of 7.5 GW h. This configuration results in a solar PV-to-electrolyser power ratio of about 1.8. Consequently, not all the electricity can be utilised by the electrolyser during peak PV production. Indeed, the electrolyser represents a significant cost factor; thus, sizing it to match the maximum solar PV output would substantially increase costs and result in a low number of full-load hours. The optimal size of the hydrogen tank is 15 MW h (450 kg of hydrogen), which allows the average user demand to be covered for 17 h. The share of hydrogen produced from PV electricity is 75 %, with an emission intensity of 3.27 kgCO_{2eq}/kgH₂. The optimiser does not include battery storage in the optimal solution since its capital cost cannot be offset by the increased utilisation of renewable energy alone.

3.2. Sensitivity to green hydrogen incentives

The base case solution resulted in a higher LCOH than the threshold of 2.3 €/kg, which is necessary for hydrogen to be considered cost-effective, compared to methane, for the average cost of natural gas in 2023 for non-domestic users [57]. Therefore, a sensitivity analysis that included incentives for green hydrogen production was conducted, as described in the introduction and methodology sections. Such incentives led to significant increases in the component sizes (Fig. 3). It is important to note that the maximum CAPEX incentive presented here does not necessarily mean it has been fully obtained, as it depends on the share of renewable energy used by the electrolyser (see Chapter 2, incentives).

In the scenario with the highest incentive value, the PV capacity

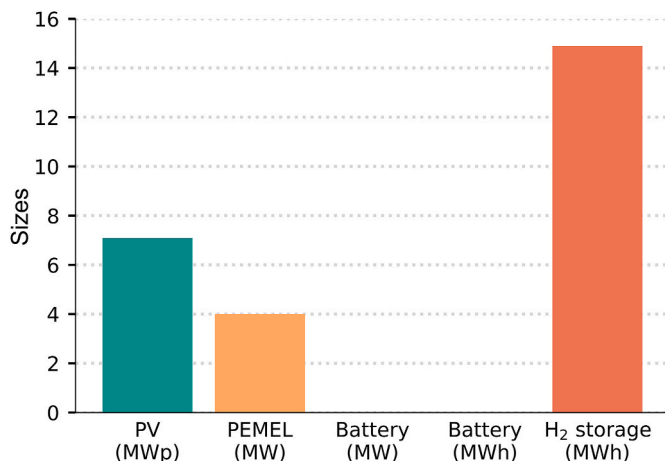

Fig. 2. Optimal component sizes in the base case.

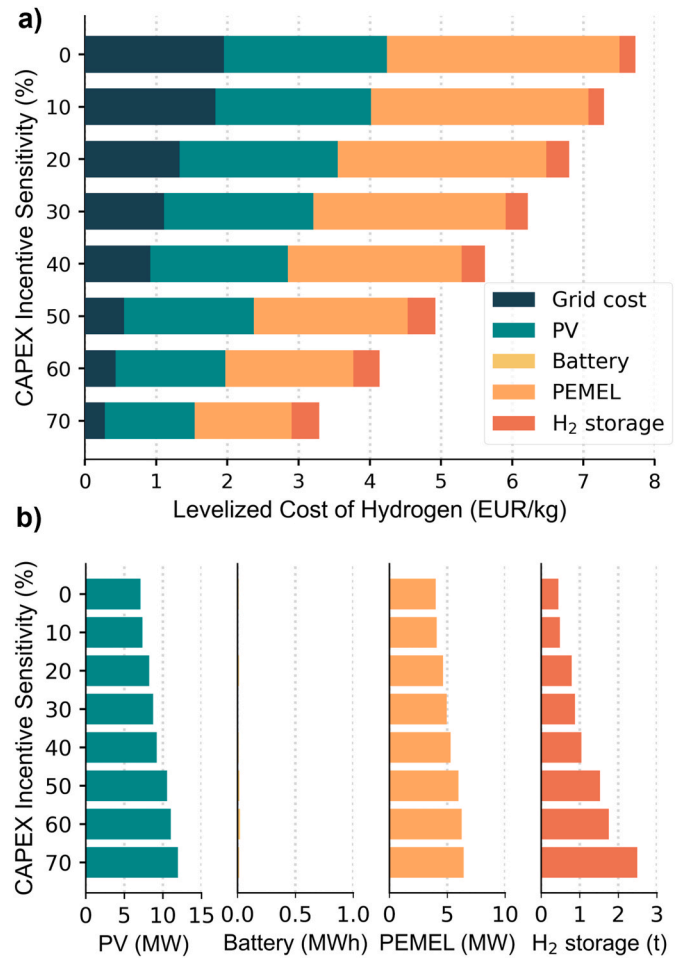

Fig. 3. Optimised hydrogen production system considering incentives under the Italian hydrogen valley scheme. a) cost composition b) optimised sizes of the PV plant, Li-Ion Battery, PEM electrolyser (PEMEL) and the hydrogen storage.

increases by 68 % and electrolyser capacity by 61 %, with respect to the non-incentivised base case. The size of hydrogen storage increases more than fivefold. Small battery are adopted in the incentivised scenarios, and the optimal size increases slightly for higher incentives. However, their values remain negligible, compared to other plant components. Moreover, this increase in battery size might be due to the granularity and metaheuristic nature of the optimisation algorithm, which might not find the exact optimal solution, and this allows small battery storage within the solution tolerance.

Fig. 4 shows the optimal solution for different incentive values. The land occupation, or land footprint, of the plant is depicted as circles of different sizes, with the colour of the circle indicating the H₂ emission intensity. The plant footprint increases significantly from 14 ha in the unincentivised scenario to 24 ha for the maximum incentive case. Most of this land occupation increase occurs in highly incentivised scenarios above 40 %, which are mainly attributable to larger PV installations. The drawback of the increased component sizes is a lower PV utilisation of H₂ production, which drops from 83 % to 65 % in the maximum incentivised scenario. In fact, as no electricity sale is allowed when the project benefits from the incentives, this is problematic and leaves a significant share of the PV electricity unutilised [13].

The incentives lead to a significant capital cost reduction, thus making the produced hydrogen more competitive (Fig. 3). The lowest hydrogen production cost of 3.46 EUR/kg is achieved for the maximum incentive of 70 %. In a similar manner, the incentives reduce the cost of the electrolyser and PV plant, while the total hydrogen storage

investment increases due to the massive surge in installed capacity to store surplus hydrogen production. Additionally, expenditure on electricity from the grid is significantly reduced. Fig. 4 provides further insights into the impact of the incentives on the capital costs and compares them with fossil fuel-based supply. However, green hydrogen does not reach cost parity with natural gas, even in the highest incentive scenario. This is considering a natural gas price of 68 €/MWh on the basis of Eurostat data for industrial consumers in Italy for the second half of 2023 [57,58]. However, if blue hydrogen is considered, green hydrogen can be competitive for highly incentivised scenarios, when the same natural gas price and a 93 % CO₂ capture rate are assumed.

Incentives also impact emissions to a great extent (Fig. 4). Although the intensity of hydrogen emissions in the base case exceeds the threshold of 3 kg_{CO₂eq}/kg_{H₂} set by the EU, the considered incentives allow emissions to be significantly reduced and the produced hydrogen to be classified as renewable. Indeed, when the maximum incentive is applied, the emissions decrease to 0.47 kg_{CO₂eq}/kg_{H₂}, as more than 96 % of the hydrogen originates from self-produced renewable electricity.

3.3. Sensitivity to the electrolyser and PV cost

In order to explore the influence of capital costs in more detail, we varied the costs of the electrolyser and PV separately, for both a non-incentivised and a maximum incentivised case. These components had both been identified as the main cost drivers in the previous analysis, and both are characterised by significant projected cost reductions [59, 60].

In this analysis, the cost reductions for the solar components significantly impacted the LCOH, compared to the base case scenario of 800 EUR/kWp for solar PV and 1100 EUR/kW for the electrolyser (Fig. 5). The optimal plant configuration resulted in LCOH values of up to 10.3 EUR/kg in the higher cost scenario. An average cost reduction of 40 % can be expected for electrolysers and 38 % for PV for future cost reductions until 2030, when considering a stated policy scenario of the World Energy Outlook 2023 [52]. Applying these learning rates to the CAPEX of the base case translates into PV costs of 500 EUR/kWp and electrolyser costs of 660 EUR/kW. Under these conditions, an LCOH of 5.4–5.5 EUR/kg is achieved. Considering the stated policy scenarios for 2050, further CAPEX reductions would result in an LCOH of less than 4.6 EUR/kg. The electrolyser and PV cost reductions contribute in a similar way to the overall LCOH reductions.

LCOH values as low as 2 EUR/kg could be reached by combining the

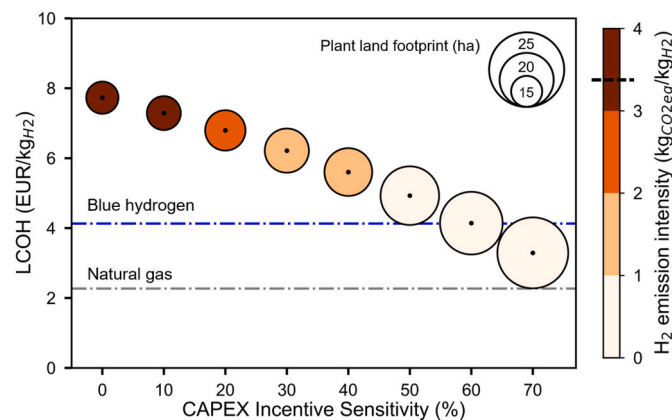

Fig. 4. Impact of the CAPEX incentives on the LCOH, emissions and land footprint. A natural gas price of 68 €/MWh was used [56]. The blue hydrogen cost is based on the same natural gas price and a 93 % CO₂ capture rate [57]. The black line in the colour bar indicates the EU's requirement to define hydrogen as renewable at 3.38 kg_{CO₂eq}/kg_{H₂}. (For interpretation of the references to colour in this figure legend, the reader is referred to the Web version of this article.)

reduced CAPEX and the highest investigated incentive case (Fig. 6). The combination of incentives and lower equipment costs further favours the selection of larger renewable plants and electrolysers, and therefore of reducing the electricity supply from the grid. A reduction in the hydrogen production cost from 54 to 59 %, caused by the incentives, can be observed by comparing the LCOH values in Fig. 5 with those in Fig. 6. This result is in line to what was observed in Section 3.2. A linear relationship of the LCOH, in function of the PV and electrolyser cost, can be observed (Fig. 7).

If the linear regressions of the data points presented in Figs. 5 and 6 are considered, a strong linear dependency of the LCOH on the CAPEX of the electrolyser and solar PV emerges. This dependency is described by Equation (9), where the LCOH is expressed as EUR/kg, while PV and PEMEL are the specific CAPEX in EUR/kW. The same regressions were considered for the incentivised scenario in Equation (10).

$$LCOH = 0.00283 \bullet (PV + PEMEL) + 2.26 \quad (9)$$

$$LCOH = 0.00129 \bullet (PV + PEMEL) + 0.77 \quad (10)$$

The regression shows a very accurate representation of the data for the non-incentivised case and a high statistical significance, with squared values of R of 0.994. The linear representation of the 70 % incentives case also shows a very accurate representation of the simulation data. These results highlight that such a linearisation is a valid approach and only shows minimal differences from the real results of the simulations. This means that, for the scope of the investigated case study, it is possible to easily calculate the LCOH for any given CAPEX over the observed range. Thus, an estimation of the LCOH is possible without conducting a complex simulation, which requires programming know-how and computational resources.

3.4. Sensitivity to the battery storage cost

Battery storage could increase the utilisation of self-produced PV electricity and reduce reliance on grid electricity. However, no significant battery storage was present in any of the analysed cases. This raises the question of what cost reductions are necessary to make battery storage cost-effective. The effect of battery cost decreases in a non-incentivised case is examined in this section to address this question.

No battery storage is included in the scenarios ranging from 0 % (base case scenario) to a 50 % cost reduction (Fig. 8). However, starting from a 60 % cost decrease, battery storage becomes part of the cost-optimal solution, beginning with a capacity of 3.8 MW h. The battery capacity increases for more marked cost declines to over 10 MW h and reaches 20 MW h in an extreme scenario with a 90 % cost reduction. Simultaneously, the battery energy-to-power ratio increases from 3.1 h, for a 50 % cost reduction, to 4.9 h for the largest cost reduction scenario. Although a small battery does not reduce the LCOH to any great extent, the large battery of the 90 % cost reduction case would reduce the LCOH by 1 EUR/kg to 6.8 EUR/kg. This LCOH decrease is mainly due to a reduction in the electrolyser capacity. The benefits of the battery are evident in this case: electrolyser investments can be deferred, full load hours can be increased, and load fluctuations can be reduced. Additionally, the utilisation rate of solar PV improves.

A broad sensitivity analysis has indicated that battery storage not only competes with hydrogen storage but also with the electrolyser size. We conducted a sensitivity analysis to test this hypothesis by increasing the electrolyser cost to 1500 EUR/kW, and this led to smaller electrolyser sizes. The dashed line in Fig. 8 shows the results of this scenario. Here, the battery becomes part of the optimal solution slightly earlier on, for a 50 % cost reduction. Both the installed capacity and the impact of the battery on LCOH increase. As pointed out in Ref. [32], any significant cost reductions for electrolysers would allow larger electrolyser installations to exploit more PV power during peak times, thus making the environment even less favourable for battery storage.

Installing battery storage increases the total storage capacity of the

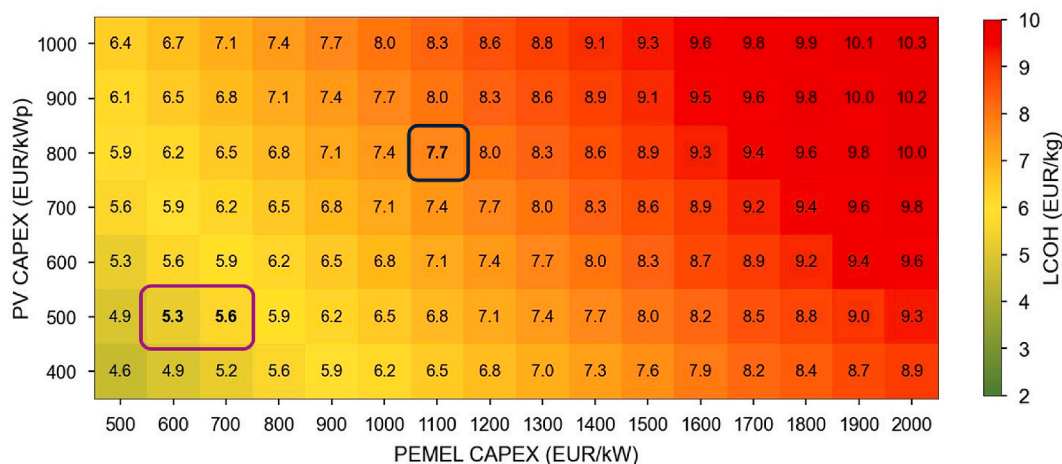

Fig. 5. LCOH in a sensitivity on electrolyser and solar PV price, using a non-incentivised case. The 2024 base case scenario is highlighted in the blue frame, The purple frame uses learning rates of the stated policy scenario of the world energy outlook 2023, extrapolating them to 2030. (For interpretation of the references to colour in this figure legend, the reader is referred to the Web version of this article.)

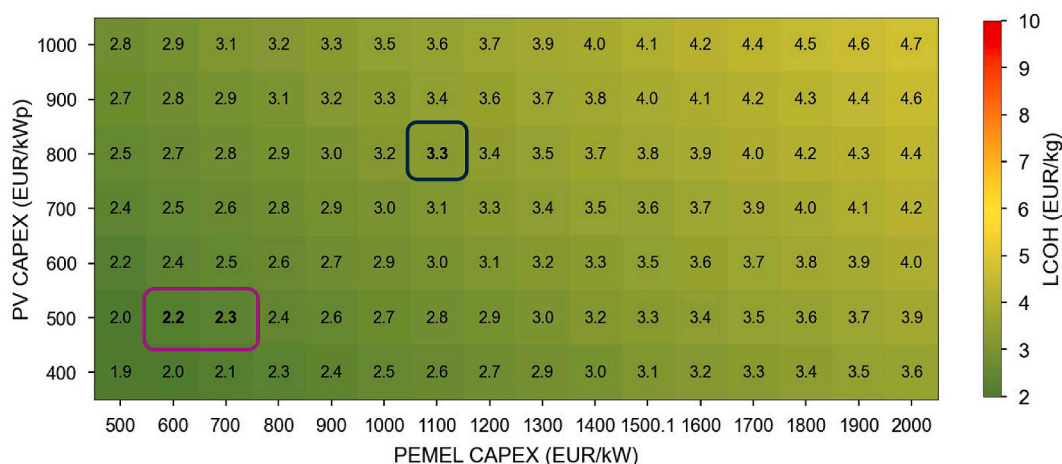

Fig. 6. LCOH in a sensitivity on electrolyser and solar PV price, using a maximum 70 % incentive case. The 2024 base case scenario is highlighted in the blue frame, The purple frame uses learning rates of the stated policy scenario of the world energy outlook 2023, extrapolating them to 2030. (For interpretation of the references to colour in this figure legend, the reader is referred to the Web version of this article.)

system, even though the size of the hydrogen tank is reduced. A hydrogen tanks remain a flexibility option downstream of the electrolyser bottleneck, even for a 90 % battery cost reduction. Without hydrogen storage, the capacity of the electrolyser would need to be sized considering the highest demand peak. However, the required electrolyser capacity could be significantly reduced for the battery and hydrogen storage working in synergy.

For completeness, we also varied the hydrogen storage costs. However, the effect of this CAPEX variation was found to be limited, compared to that of the electrolyser or solar PV cost variations (see Appendix Table A.1).

3.5. Sensitivity to the land availability constraints

The previously investigated scenarios share a common characteristic: the required land for the cost-optimal solution increases for incentives or CAPEX reductions. However, the land that is available in the proximity of an industry might be limited, thereby making the optimal component sizes unfeasible and resulting in a non-optimal configuration. The effect of limited land availability is examined in this section.

Starting from the base case, the allowed plant area was reduced by 1 ha in each step, starting from 14 ha and going down to 1 ha (Fig. 9). As

can be seen, limiting the available land increases the LCOH as the system moves away from the cost-optimal solution. Compared to the optimal configuration, reducing the footprint to 1 ha raises the LCOH by 26 % to reach 9.7 EUR/kg. The PV plant is the most significant driver of the footprint. The PV plant experiences the most substantial size reduction for land availability constraints. Only 0.5 MW of solar PV is installed in the strictest land constraint scenario, and this represents a 93 % reduction, compared to the optimal solution of the base case. This reduced PV capacity also impacts the size of the hydrogen storage tanks. As the PV supply surplus is progressively reduced, the size of the hydrogen tank is also lowered. Even when there is no PV plant, the hydrogen demand still needs to be satisfied, and this requires a substantial nominal power of the electrolyser.

When the plant footprint was set in the context of the final user’s energy demand, the land availability constraint resulted in the same energy demand being met by a smaller area (Appendix A, Figure A.1). Thus, it becomes evident that solar PV cannot satisfy the increased required power per unit of an area below a certain land availability, especially when considering seasonal production fluctuations. This leads to enhanced grid usage and explains why a limited land availability has a significant impact on the system.

Footprint constraints from 14 to 10 ha resulted in a limited effect on

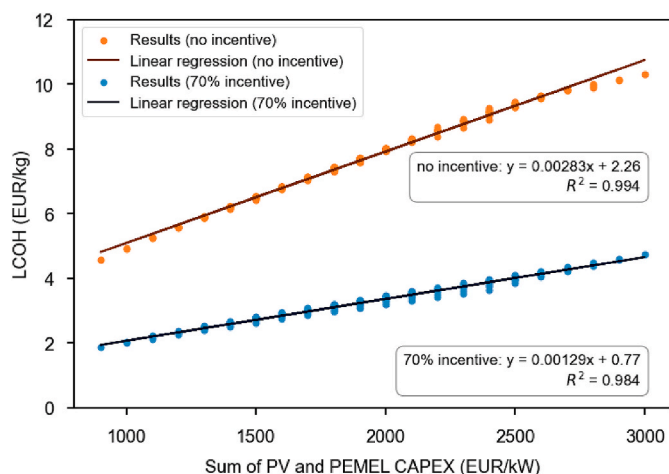

Fig. 7. LCOH in function of the Electrolyser and PV capex. The orange data represent all points of Fig. 6 and the blue data the incentivised cases of Fig. 7. The two lines show a linear regression through the corresponding data points. (For interpretation of the references to colour in this figure legend, the reader is referred to the Web version of this article.)

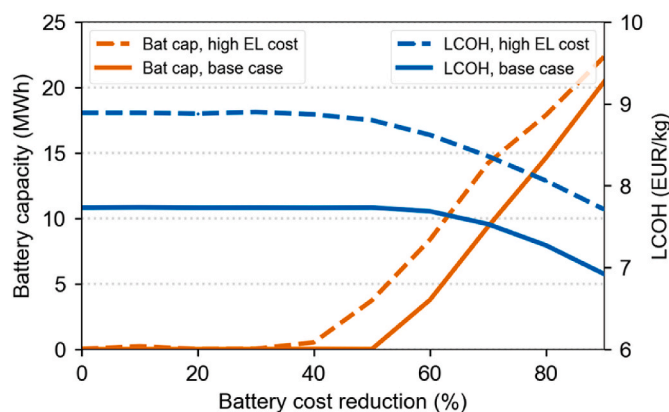

Fig. 8. Sensitivity regarding battery storage cost.

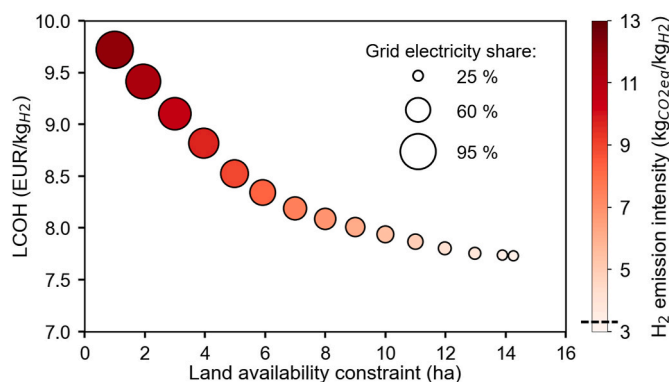

Fig. 9. LCOH and emission intensity for different land availability. The black line in the colour bar marks the EU requirement to define hydrogen as renewable at 3.38 kgCO_{2eq}/kgH₂. (For interpretation of the references to colour in this figure legend, the reader is referred to the Web version of this article.)

LCOH, which increased by about 3 %, from 7.7 to 7.9 EUR/kg. In contrast, tightening the footprint constraint to 10 ha significantly impacts the optimal PV size, reducing it from 7 MW to 5 MW. Further, this reduction of land availability had already a significant impact on the

intensity of hydrogen emissions, which increased by 71 % to 5.5 kgCO_{2eq}/kgH₂. Under a stronger footprint constraint, i.e. below 2 ha, a significant detrimental effect was observed on emission intensity, which increased to 12.0 kgCO_{2eq}/kgH₂, as the electricity was almost exclusively withdrawn from the electric grid. This emission intensity significantly exceeds the EU definition of renewable hydrogen of 3 kgCO_{2eq}/kgH₂ and falls into the same range as unabated grey hydrogen from steam methane reforming [16,58,61].

4. Discussion

In the following section, we discuss the implications of our findings regarding plant dimensioning, costs and the effects of incentives, and place the results in a broader context.

The location in central Italy has reasonable PV resources; however, it is at a clear disadvantage compared to the exceptional sites in southern Spain or the projects that include wind energy or low-cost hydropower in Scandinavia. Despite this, the site was chosen because of its proximity to industries with a potential hydrogen uptake. The obtained LCOH for the considered site is higher than the literature values or large-scale hydrogen projects [11,16,62]. However, having to rely on a single electricity source with significant seasonal fluctuations makes it challenging to satisfy the energy profile throughout the entire year. Consequently, if the results of this study are compared with those of an exclusively solar-PV-based supply, the LCOH values result to be in a comparable range to those found in recent literature [62]. However, producing hydrogen on-site has the advantage of avoiding transportation costs and the related infrastructure expenses, which could justify the surplus cost of 1–2 EUR/kg [63].

For those incentives dedicated to projects all over Europe, such as the hydrogen bank auctions, there is competition between different locations with different renewable resources, which eventually advantages those characterised by a high renewable energy potential. However, the incentive measures adopted in Italy, which we have investigated in this study, allocate a specific budget to each region in order to limit competition between regions. This increases the chances of regions with a lower renewable potential of having access to the incentives and reflects the aim of developing a distributed hydrogen production throughout the whole country. Although the incentive scenarios in this study may seem substantial, some projects might even receive higher funding, thus highlighting the significant financial contribution of this measure [8]. The downside of this scheme pertains to the production of hydrogen in areas with a lower renewable potential, which might be economically challenging, and, in this case, the need for substantial incentives will likely persist for a long time.

Our study focuses on the sizing of the hydrogen production system rather than a specific use case, making it broadly applicable to various industrial sectors with similar constant hydrogen demand and plant sizes. However, incentive schemes and regulatory frameworks vary across countries, with different definitions and requirements for green hydrogen. This is especially valid if countries outside the European Union are considered. For example, in the United States, green hydrogen policy allows the use of grid electricity and benefiting from tax cuts if a specific carbon threshold is not exceeded [64]. These differences can significantly impact plant design, highlighting the need to carefully assess adaptability based on the specific legislative and economic context.

Cost reductions for solar PV and electrolyzers have a similar effect to incentives (Figs. 3 and 4). These incentives effectively anticipate CAPEX reductions and extend them to other components, such as the hydrogen tank and battery storage, thereby resulting in a reduced reliance on the grid and lower emissions. Combining the PV and electrolyser cost reductions with the incentives further reduces the LCOH to values that are competitive with natural gas. However, this scenario is not representative of the mid-term future, as the current equipment prices are on the higher end of the investigated range. Indeed, recent studies have

indicated that electrolyser prices have not followed the previous cost reduction projections and are instead around 2000 USD/kW [41]. A comparison with fossil-based supply has shown that significant cost reductions for green hydrogen are necessary to reach cost parity and have highlighted the need for incentives. However, it should be added that the gap in costs might also be reduced, since the cost of natural gas (grey line in Fig. 4) may fluctuate significantly. Price spikes, like those experienced during the 2022 energy crisis, might shift the cost balance in favour of green hydrogen. Additionally, carbon taxes and emission trading systems, which were not included in our analysis, could increase the costs of natural gas and motivate investments in green hydrogen [29]. In doing so, it is crucial to include all the emissions of a production chain, such as those from methane leakage during natural gas production, in an analysis of various scenarios [58,63].

As far as storage is concerned, hydrogen has been found to be the most convenient energy vector in the investigated system, as it avoids bottlenecks in the electrolyser and enhances supply security. The relatively low capital cost of hydrogen tanks, compared to battery storage, also enhances their performance. Storage durations of 17 h in the base case (considering the average hourly hydrogen demand) and up to 96 h in a heavily incentivised case exceed the nighttime production pause of PV. This underscores the importance of hydrogen storage in providing flexibility during unfavourable weather periods and in acting as a buffer to reduce grid withdrawal.

Battery storage is not part of the optimal solution in the observed incentive sensitivities or even when reasonable battery cost reductions are considered. The incentivised scenarios show that when all the equipment costs are reduced, the installation of larger renewable and electrolyser plants is facilitated, which in turn hinders the economic feasibility of battery storage. This means that the business model for Li-ion batteries considered in this application might be challenging, even in the future. However, several factors could impact battery profitability. For example, considering a more accurate description of the interaction between the intermittent RES and electrolyser, and using a dedicated electrolyser degradation model in the objective function could present an advantage for battery storage as it would allow a more constant electrolyser load. Another way of improving battery storage profitability is revenue stacking, whereby the battery is used for other services when not needed by the hydrogen production system. Additionally, battery storage could be advantaged for higher grid electricity prices, as reducing costly grid withdrawal is one of the potential strengths of battery storage. The system typically relies on the grid during prolonged periods of unfavourable weather, which can be associated with lower PV production across the rest of the bidding zone, thereby justifying a higher electricity cost. For this reason, we conducted the same analysis using an increased electricity cost of 200 EUR/MWh. The results indicated a slight improvement in battery storage profitability, but not a major impact (see Appendix Table A.2). Furthermore, analysing an off-grid scenario could lead to different evaluations.

The results of the sensitivity analysis on land availability underscore its crucial role in cost-effectiveness and the environmental impact of renewable hydrogen production systems (Chapter 3.5), especially pertaining to the Italian context. Italian legislation on “*Aree idonee*” [65] (suitable areas for renewable projects) allows regional authorities to define suitable and unsuitable zones for renewable installations and to prioritize environmental and cultural preservation while supporting renewable targets. Certain agricultural areas may be allowed to host renewable projects, albeit under strict conditions, emphasising proximity to industrial zones or alignment with state initiatives. This constraint could limit the land available for renewable installations, thereby potentially pushing the system away from its cost-optimal configuration, and it could result in a higher LCOH and an increased emission intensity. These insights highlight how important it is for project developers to secure adequate land early on during the planning phase to avoid compromising both the economic and environmental goals. Policymakers could consider refining land-use regulations to

facilitate renewable energy projects in underutilised or dual-use areas, thereby becoming aligned with Italy’s commitment to balancing renewable targets with land preservation.

5. Conclusions

Hydrogen is a promising pathway towards the decarbonisation of hard-to-abate industries, although a significant cost gap remains, compared with fossil fuel-based supply. In this article, we have analysed a hydrogen production system in an Italian-centred case study. We have used Particle Swarm Optimisation to find the optimal component sizes and examine the impact of incentives on the LCOH and emissions.

An LCOH of 7.73 EUR/kg was obtained in the base case, thus highlighting a substantial cost gap with fossil fuel-based hydrogen production. Incentives, such as project calls on hydrogen production in abandoned industrial areas, are crucial to reduce these costs. Analysing incentives of up to 70 % of CAPEX, we found that the LCOH can be reduced to 3.29 EUR/kg, which, however, is not enough to reach cost parity considering the 2023 natural gas prices. Moreover, this incentive is slightly below the funding some of the awarded projects receive.

The findings also suggest that cost reductions incentivise the installation of more PV power and the storage of excess energy, thereby reducing grid withdrawal and the carbon footprint. We found that the emission intensity reduced from 3.27 kgCO_{2eq}/kgH₂ to 0.47 kgCO_{2eq}/kgH₂. The incentives showed an effect that is comparable to anticipating the expected cost reduction, particularly for electrolysers and solar PV. However, achieving cost parity with natural gas requires more favourable renewable energy inputs, such as the integration of wind energy or a more advantageous location.

The downside of incentives or lower equipment costs is that the plant footprint increases. If the available land is limited, as may be the case for industrial clients, non-optimal configurations may be observed with higher levelised costs and emissions. The most significant driver of the footprint is PV installation, which provides the input electricity and therefore influences the sizing of all the other components.

Hydrogen storage covers durations of more than 17 h, which can be further increased with incentives and cost reductions. These large capacities are reached as a result of the advantage of hydrogen as an energy vector downstream of the electrolyser, which enhances supply security. Conversely, battery storage is not cost-effective for a grid-connected case, as indicated in this article. The sensitivity analysis regarding battery storage cost suggests that, even in the future, the business case for battery storage will likely remain challenging in grid-connected applications if used solely for hydrogen production.

By conducting a sensitivity analysis on electrolyser and solar PV CAPEX, we discovered a robust linear relationship between the equipment cost and LCOH for the investigated case study. This relationship allows for cost estimates without the need for simulations, representing a significant advantage.

The present work could be enhanced by adding more details for the modelling of the components, particularly regarding the electrolyser, battery degradation and self-discharge. The lack of optimisation in plant scheduling and the impact of dynamic, volatile electricity prices are recognised limitations of this study. Future research will examine alternative plant configurations and connection schemes to assess the influence of grid interaction on the design and costs of a plant. Additionally, upcoming studies will explore more favourable sites with superior renewable energy resources to address some of the constraints identified in this study.

CRediT authorship contribution statement

Marcel Stolte: Writing – review & editing, Writing – original draft, Visualization, Software, Methodology, Investigation, Data curation. **Francesco Demetrio Minuto:** Writing – review & editing, Visualization, Validation, Supervision, Methodology, Formal analysis,

Conceptualization. **Alessandro Perol**: Supervision, Project administration. **Massimiliano Bindì**: Supervision, Project administration. **Andrea Lanzini**: Writing – review & editing, Supervision, Funding acquisition, Conceptualization.

Declaration of competing interest

The authors declare that they have no known competing financial interests or personal relationships that could have appeared to influence the work reported in this paper.

Acknowledgements

M. Stolte carried out this study as part of the PNRR-NGEU project, which has received funding from the MUR – DM 117/2023.

F.D. Minuto carried out this study within Ministerial Decree no. 1062/2021 and received funding from the FSE REACT-EU - PON Ricerca e Innovazione, 2014–2020.

A. Lanzini carried out this study within the National Recovery and Resilience Plan (PNRR) and received funding from the Italian Ministry of the Environment and Energy Security, the “Novel Materials for Hydrogen storage (NoMaH)” project, ID RSH2A_000035, CUP: F27G22000180006.

This manuscript only reflects the authors’ views and opinions, and neither the European Union nor the European Commission can be considered responsible for them.

Appendix A. Supplementary data

Supplementary data to this article can be found online at <https://doi.org/10.1016/j.ijhydene.2025.03.008>.

References

- [1] ‘Tracking Clean Energy Progress - Industry’, International Energy Agency. Accessed: February. 14, 2024. [Online]. Available: <https://www.iea.org/energy-system/industry>.
- [2] ‘Assessment of green hydrogen for industrial heat’, Deloitte [Online]. Available: <https://www2.deloitte.com/us/en/pages/energy-and-resources/articles/green-hydrogen.html>. [Accessed 13 November 2023].
- [3] Bade SO, Tomomewo OS, Meenakshisundaram A, Ferron P, Oni BA. Economic, social, and regulatory challenges of green hydrogen production and utilization in the US: a review. *Int J Hydrogen Energy* 2024;49:314–35. <https://doi.org/10.1016/j.ijhydene.2023.08.157>.
- [4] Pastore LM, Lo Basso G, Sforzini M, Livio de S. Technical, economic and environmental issues related to electrolyzers capacity targets according to the Italian Hydrogen Strategy: a critical analysis. *Renew Sustain Energy Rev* 2022;166. <https://doi.org/10.1016/j.rser.2022.112685>.
- [5] Islam A, et al. Accelerating the green hydrogen revolution: a comprehensive analysis of technological advancements and policy interventions. *Int J Hydrogen Energy* May 2024;67:458–86. <https://doi.org/10.1016/j.ijhydene.2024.04.142>.
- [6] Pingkuo L, Junqing G. Comparative analysis on the development potential of green hydrogen industry in China, the United States and the European Union. *Int J Hydrogen Energy Sep.* 2024;84:700–17. <https://doi.org/10.1016/j.ijhydene.2024.08.298>.
- [7] Gatto A, Sadik-Zada ER, Lohoff T, Aldieri L, Vinci CP, Peitz KA. An exemplary subsidization path for the green hydrogen economy uptake: rollout policies in the United States and the European Union. *J Clean Prod Feb.* 2024;440:140757. <https://doi.org/10.1016/j.jclepro.2024.140757>.
- [8] Australian government and Department of Climate Change, Energy, the environment and water, ‘Australia’s national hydrogen strategy - DCCEEW’ [Online]. Available: <https://www.dcceew.gov.au/energy/publications/australia-s-national-hydrogen-strategy>. [Accessed 28 October 2024].
- [9] European Union, ‘Directives directive (EU) 2018/2001 of the European parliament and of the council of 11 December 2018 on the promotion of the use of energy from renewable sources (recast) (Text with EEA relevance)’. .
- [10] EU. Commission delegated regulation (EU) 2023/1184 [Online]. Available: https://eur-lex.europa.eu/legal-content/EN/TXT/?toc=OJ%3AL%3A2023%3A157%3ATOC&uri=uriserv%3AOJ.L_.2023.157.01.0011.01.ENG. [Accessed 5 September 2023].
- [11] European Hydrogen Bank auction provides €720 million [Online]. Available: https://ec.europa.eu/commission/presscorner/detail/en/ip_24_2333. [Accessed 3 May 2024].
- [12] ‘Second renewable hydrogen auction: European commission publishes terms and conditions - European commission’. European commission [Online]. Available: https://climate.ec.europa.eu/news-your-voice/news/second-renewable-hydrogen-auction-european-commission-publishes-terms-and-conditions-2024-09-27_en. [Accessed 24 October 2024].
- [13] Investimento 3.1 - Produzione di idrogeno in aree industriali dismesse (Hydrogen Valleys) | Ministero dell’Ambiente e della Sicurezza Energetica [Online]. Available: <https://www.mase.gov.it/bandi/investimento-3-1-produzione-di-idrogeno-no-aree-industriali-dismesse-hydrogen-valleys>. [Accessed 3 May 2024].
- [14] Piedmont Region, ‘PNRR M2C2 Investimento 3.1 “Produzione di idrogeno in aree industriali dismesse” fin. EU NextGenerationEU | Bandi Regione Piemonte’. Accessed: October. 24, 2024. [Online]. Available: <https://bandi.regione.piemonte.it/contributi-finanziamenti/pnrr-m2c2-investimento-31-produzione-idrogeno-aree-industriali-dismesse-fin-eu-nextgenerationeu>.
- [15] Schiebahn S, Grube T, Robinius M, Tietze V, Kumar B, Stolten D. Power to gas: technological overview, systems analysis and economic assessment for a case study in Germany. *Int J Hydrogen Energy Apr.* 2015;40(12):4285–94. <https://doi.org/10.1016/j.ijhydene.2015.01.123>.
- [16] Mingolla S, et al. Effects of emissions caps on the costs and feasibility of low-carbon hydrogen in the European ammonia industry. *Nat Commun May* 2024;15(1):3753. <https://doi.org/10.1038/s41467-024-48145-z>.
- [17] Masihiy C E, Carvajal D, Oliva H S. Impact of delivery time, local renewable sources, and generation curtailment on the levelized cost of hydrogen. *Appl Energy Jun.* 2024;364:123143. <https://doi.org/10.1016/j.apenergy.2024.123143>.
- [18] Barhoumi EM, et al. Techno-economic analysis of photovoltaic-hydrogen refueling station case study: a transport company Tunis-Tunisia. *Int J Hydrogen Energy Jul.* 2022;47(58):24523–32. <https://doi.org/10.1016/j.ijhydene.2021.10.111>.
- [19] Weiss R, Ikäheimo J. Flexible industrial power-to-X production enabling large-scale wind power integration: a case study of future hydrogen direct reduction iron production in Finland. *Appl Energy Jul.* 2024;365:123230. <https://doi.org/10.1016/j.apenergy.2024.123230>.
- [20] Brandt J, et al. Cost and competitiveness of green hydrogen and the effects of the European Union regulatory framework. *Nat Energy May* 2024;1–11. <https://doi.org/10.1038/s41560-024-01511-z>.
- [21] Odenweller A, Ueckerdt F. The green hydrogen ambition and implementation gap. *Nat Energy Jan.* 2025;10(1):110–23. <https://doi.org/10.1038/s41560-024-01684-7>.
- [22] Lucas TR, Ferreira AF, Santos Pereira RB, Alves M. Hydrogen production from the WindFloat Atlantic offshore wind farm: a techno-economic analysis. *Appl Energy Mar.* 2022;310:118481. <https://doi.org/10.1016/j.apenergy.2021.118481>.
- [23] Dufo-López R, Lujano-Rojas JM, Bernal-Agustín JL. Optimisation of size and control strategy in utility-scale green hydrogen production systems. *Int J Hydrogen Energy Jan.* 2024. <https://doi.org/10.1016/j.ijhydene.2023.08.273>.
- [24] Gökçek M, et al. Optimum sizing of hybrid renewable power systems for on-site hydrogen refuelling stations: case studies from Türkiye and Spain. *Int J Hydrogen Energy Mar.* 2024;59:715–29. <https://doi.org/10.1016/j.ijhydene.2024.02.068>.
- [25] Borges RP, Franco F, Serralha FN, Cabrita I. Green hydrogen production at the gigawatt scale in Portugal: a technical and economic evaluation. *Energies Jan.* 2024;17(7). <https://doi.org/10.3390/en17071638>. Art. no. 7.
- [26] Nanaki EA, Kiartzis S, Xydis G. Is Greece ready for a hydrogen energy transition?—quantifying relative costs in hard to abate industries. *Energies Jan.* 2024;17(7). <https://doi.org/10.3390/en17071722>. Art. no. 7.
- [27] Skordoulas N, Karellas S, Lyridis DV, Giannisi SG, Mitkidis G. RES-electrolyser coupling within TRIERES hydrogen valley – a flexible techno-economic assessment tool. *Energy Convers Manag Mar.* 2025;327:119562. <https://doi.org/10.1016/j.enconman.2025.119562>.
- [28] Hill SJP, Bamisile O, Hatton L, Staffell I, Jansen M. The cost of clean hydrogen from offshore wind and electrolysis. *J Clean Prod Mar.* 2024;445:141162. <https://doi.org/10.1016/j.jclepro.2024.141162>.
- [29] Janssen JLLCC, Weeda M, Detz RJ, van der Zwaan B. Country-specific cost projections for renewable hydrogen production through off-grid electricity systems. *Appl Energy Mar.* 2022;309:118398. <https://doi.org/10.1016/j.apenergy.2021.118398>.
- [30] Bukar AL, Chaitusaney S, Kawabe K. Optimal energy management and techno-economic assessment of hydrogen energy production system incorporated with photovoltaic and battery storage. *Int J Hydrogen Energy Apr.* 2024;62:1139–53. <https://doi.org/10.1016/j.ijhydene.2024.03.058>.
- [31] Martinez Lopez VA, Ziar H, Haverkort JW, Zeman M, Isabella O. Dynamic operation of water electrolyzers: a review for applications in photovoltaic systems integration. *Renew Sustain Energy Rev Aug.* 2023;182:113407. <https://doi.org/10.1016/j.rser.2023.113407>.
- [32] Ibanez-Rioja A, Kauranen P. Off-grid solar PV–wind power–battery–water electrolyzer plant: simultaneous optimization of component capacities and system control. *Appl Energy Sep.* 2023;345:121277. <https://doi.org/10.1016/j.apenergy.2023.121277>.
- [33] Ciancio A, De Santoli L. Assessing the levelized cost of hydrogen production in a renewable hydrogen community in south Italy. In: 2023 IEEE international conference on environment and electrical engineering and 2023 IEEE industrial and commercial power systems Europe (EEEIC/I&CPS Europe); Jun. 2023. p. 1–6. <https://doi.org/10.1109/EEEIC/ICPSEurope57605.2023.10194654>.
- [34] Morocco P, Gandiglio M, Santarelli M. Optimal design of PV-based grid-connected hydrogen production systems. *J Clean Prod Jan.* 2024;434:140007. <https://doi.org/10.1016/j.jclepro.2023.140007>.
- [35] Gandiglio M, Morocco P. Mapping hydrogen initiatives in Italy: an overview of funding and projects. *Energies Jan.* 2024;17(11). <https://doi.org/10.3390/en17112614>. 11.
- [36] Davis NN, et al. The global wind atlas: a high-resolution dataset of climatologies and associated web-based application. *Bull Am Meteorol Soc Aug.* 2023;104(8):E1507–25. <https://doi.org/10.1175/BAMS-D-21-0075.1>.

- [37] Superchi F, Mati A, Carcaschi C, Bianchini A. Techno-economic analysis of wind-powered green hydrogen production to facilitate the decarbonization of hard-to-abate sectors: a case study on steelmaking. *Appl Energy Jul.* 2023;342:121198. <https://doi.org/10.1016/j.apenergy.2023.121198>.
- [38] Stolte M, Minuto FD, Lanzini A. Optimizing green hydrogen production from wind and solar for hard-to-abate industrial sectors across multiple sites in Europe. *Int J Hydrogen Energy Aug.* 2024;79:1201–14. <https://doi.org/10.1016/j.ijhydene.2024.07.106>.
- [39] IRENA. Renewable power generation costs in 2022. IRENA; Aug. 2023 [Online]. Available: <https://www.irena.org/Publications/2023/Aug/Renewable-Power-Generation-Costs-in-2022>. [Accessed 28 May 2024].
- [40] Novo R, Minuto FD, Bracco G, Mattiazio G, Borchiellini R, Lanzini A. Supporting decarbonization strategies of local energy systems by de-risking investments in renewables: a case study on Pantelleria Island. *Energies Jan.* 2022;15(3). <https://doi.org/10.3390/en15031103>. Art. no. 3.
- [41] ng SF, Cinzia NIEDDU Arch C N Arch. Realizzazione impianto fotovoltaico a terra da 24,49 MW in immissione, tipo ad inseguimento monoassiale "SAM-SE" comuni di SAMASSI E SERRENTI (SU)'. *ENERGYSAMSE SRL*; 2022.
- [42] Eurostat. Electricity prices for non-household consumers - bi-annual data (from 2007 onwards). https://doi.org/10.2908/NRG_PC_205; 2025.
- [43] European Environmental Agency. Greenhouse gas emission intensity of electricity generation in Europe [Online]. Available: <https://www.eea.europa.eu/en/analysis/indicators/greenhouse-gas-emission-intensity-of-1>. [Accessed 21 February 2024].
- [44] Plazas-Niño FA, Yeganyan R, Cannone C, Howells M, Borba B, Quirós-Tortós J. Assessing the role of low-emission hydrogen: a techno-economic database for hydrogen pathways modelling. *Data Brief Feb.* 2024;52:109822. <https://doi.org/10.1016/j.dib.2023.109822>.
- [45] Rozzi E, Minuto FD, Lanzini A. Techno-economic dataset for hydrogen storage-based microgrids. *Data Brief Oct.* 2024;56:110795. <https://doi.org/10.1016/j.dib.2024.110795>.
- [46] Joint Research Centre (European Commission), Davies J, Dolci F, Weidner E. Historical analysis of FCH 2 JU electrolyser projects: evaluation of contributions towards advancing the state of the art. Publications Office of the European Union; 2021 [Online]. Available: <https://data.europa.eu/doi/10.2760/951902>. [Accessed 9 May 2024].
- [47] 'Introducing Megapack: Utility-Scale Energy Storage | Tesla Italy', Tesla. Accessed: May 10, 2024. [Online]. Available: https://www.tesla.com/it_it/blog/introducing-megapack-utility-scale-energy-storage.
- [48] National Renewable Energy Laboratory. Electricity annual technology baseline (ATB) data 2022. National Renewable Energy Laboratory; 2022 [Online]. Available: <https://atb.nrel.gov/electricity/2022/data>. [Accessed 24 January 2024].
- [49] Grimaldi A, Minuto FD, Perol A, Casagrande S, Lanzini A. Ageing and energy performance analysis of a utility-scale lithium-ion battery for power grid applications through a data-driven empirical modelling approach. *J Energy Storage Aug.* 2023;65:107232. <https://doi.org/10.1016/j.est.2023.107232>.
- [50] Baglioni S.p.A., 'Catalogo serbatoi stoccaggio idrogeno'. [Online]. Available: <http://s://baglionispa.com/idrogeno/>.
- [51] Elsheikh H, Evelyn V. Renewable hydrogen based direct iron ore reduction and steel making with grid assistance. *Energy Convers Manag Dec.* 2023;297:117544. <https://doi.org/10.1016/j.enconman.2023.117544>.
- [52] 'World Energy Outlook 2023 – Analysis', IEA. Accessed: May 16, 2024. [Online]. Available: <https://www.iea.org/reports/world-energy-outlook-2023>.
- [53] Holst M, Aschbrenner S. Cost forecast for low-temperature electrolysis - technology driven bottom-up prognosis for PEM and alkaline water electrolysis systems. Fraunhofer Institute for Solar Energy Systems ISE. 2021 [Online]. Available: <https://publica.fraunhofer.de/entities/publication/5a0b888c-453c-449b-9dbb-d18f61c3abee/details>.
- [54] Marocco P, Novo R, Lanzini A, Mattiazio G, Santarelli M. Towards 100% renewable energy systems: the role of hydrogen and batteries. *J Energy Storage 2023;57(Jan)*. <https://doi.org/10.1016/j.est.2022.106306>.
- [55] Urs RR, Chadly A, Al Sumaiti A, Mayyas A. Techno-economic analysis of green hydrogen as an energy-storage medium for commercial buildings. *Clean Energy Feb.* 2023;7(1):84–98. <https://doi.org/10.1093/ce/zkac083>.
- [56] Atabay R, Devrim Y. Design and techno-economic analysis of solar energy based on-site hydrogen refueling station. *Int J Hydrogen Energy Aug.* 2024;80:151–60. <https://doi.org/10.1016/j.ijhydene.2024.07.166>.
- [57] Eurostat. Gas prices for non-household consumers - bi-annual data (from 2007 onwards). Eurostat 2024. https://doi.org/10.2908/NRG_PC_203.
- [58] International Energy Agency. Towards hydrogen definitions based on their emissions intensity. OECD; 2023. <https://doi.org/10.1787/44618fd1-en>.
- [59] Wiser R, et al. Expert elicitation survey predicts 37% to 49% declines in wind energy costs by 2050. *Nat Energy May* 2021;6(5). <https://doi.org/10.1038/s41560-021-00810-z>. 5.
- [60] 2030 Solar cost targets', United States Department of Energy. Accessed: August. 31, 2023. [Online]. Available: <https://www.energy.gov/eere/solar/articles/2030-solar-cost-targets>.
- [61] Commission delegated regulation (EU) 2023/1185 of 10 February 2023 [Online]. Available: http://data.europa.eu/eli/reg_del/2023/1185/oj/eng. [Accessed 10 November 2023].
- [62] McKenzie H. DOE hydrogen program record 24005: clean hydrogen production cost scenarios with PEM electrolyzer technology, vol. 24005. United States Department of Energy; May 2024 [Online]. Available: https://www.hydrogen.energy.gov/docs/hydrogenprogramlibraries/pdfs/24005-clean-hydrogen-production-cost-pem-electrolyzer.pdf?sfvrsn=8cb10889_1. [Accessed 7 March 2024].
- [63] 'Global Hydrogen Review 2023 – Analysis', IEA. Accessed: May 24, 2024. [Online]. Available: <https://www.iea.org/reports/global-hydrogen-review-2023>.
- [64] Financial Incentives for Hydrogen and Fuel Cell Projects', Energy.Gov. Accessed: February. 24, 2025. [Online]. Available: <https://www.energy.gov/eere/fuelcell/s/financial-incentives-hydrogen-and-fuel-cell-projects>.
- [65] Ministero dell'Ambiente e della Sicurezza Energetica. Disciplina per l'individuazione di superfici e aree idonee per l'installazione di impianti a fonti rinnovabili. Decreto del 21 giugno 2024. Gazzetta Ufficiale della Repubblica Italiana July 2, 2024;Serie Generale:153 [Online]. Available: https://www.gazzettaufficiale.it/atto/serie_generale/caricaDettaglioAtto/originario?atto.data PubblicazioneGazzetta=2024-07-02&atto.codiceRedazionale=24A03360&elenco30giorni=true. [Accessed 31 October 2024].