

Controllability of dynamical systems with Play-type hysteresis via approximation by delayed relays

Original

Controllability of dynamical systems with Play-type hysteresis via approximation by delayed relays / Bagagiolo, F., Recupero, V., Zoppello, M.. - In: MATHEMATICS IN ENGINEERING. - ISSN 2640-3501. - 7:4(2025), pp. 439-463. [10.3934/mine.2025018]

Availability:

This version is available at: 11583/3002048 since: 2025-07-23T15:37:32Z

Publisher:

AIMS Press

Published

DOI:10.3934/mine.2025018

Terms of use:

This article is made available under terms and conditions as specified in the corresponding bibliographic description in the repository

Publisher copyright

(Article begins on next page)



Research article

Controllability of dynamical systems with Play-type hysteresis via approximation by delayed relays[†]

Fabio Bagagiolo^{1,*}, Vincenzo Recupero² and Marta Zoppello²

¹ Department of Mathematics, University of Trento, Italy

² Department of Mathematical Sciences, Politecnico di Torino, Italy; vincenzo.recupero@polito.it, marta.zoppello@polito.it

[†] **This contribution is part of the Special Issue: Multi-Rate Processes and Hysteresis**

Guest Editors: Menita Carozza; Dmitrii Rachinskii; Ciro Visone

Link: www.aimspress.com/mine/article/6692/special-articles

* **Correspondence:** Email: fabio.bagagiolo@unitn.it.

Abstract: In this paper we study the controllability problem for systems exhibiting hysteresis represented by play-type operators. To this end we first formalize and study in a functional setting the approximation of the Play operators by a finite weighted sum of delayed relay. Then we prove the controllability for the case with the Play operator, by the controllability result for the case with the weighted sum of delayed relay. Finally, we discuss potential applications of our approach to the sweeping process.

Keywords: controllability of differential systems; hysteresis

1. Introduction

In this paper we are concerned with the controllability of systems of the kind

$$\begin{cases} z'(t) = \sum_{j=1}^m g_j(z(t), w_j(t)) u_j(t), \\ w_j(t) = \mathcal{G}_j[z, w_j^0](t), \quad \forall j = 1, \dots, m, \\ z(0) = A, \end{cases} \quad (1.1)$$

where, for some fixed $T > 0$, the unknown is $z : [0, T] \rightarrow \mathbb{R}^n$, the controls $u_j : [0, T] \rightarrow U_j \subseteq \mathbb{R}$ are measurable, $g_j : W_j \times \mathbb{R}^n \rightarrow \mathbb{R}^n$ are smooth fields, \mathcal{G}_j are hysteresis operators with outputs w_j taking

values in $W_j \subseteq \mathbb{R}^p$, and $A \in \mathbb{R}^n$, $w_j^0 \in W_j$ are initial states. By hysteresis (see Visintin [28]) we mean an input/output relationship between two time-dependent quantities which presents some particular memory effects, in particular the so-called rate-independence, a sort of time scaling invariance, which gives to the system a strong nonlocal feature. In the second line of (1.1), z is the input and w_j is the output. We also point out that, for an actual value $z(t)$ of the input, we may have several different possible values for the output $w_j(t)$, depending on the evolution of z in $[0, t]$ that has brought z to the value $z(t)$. This brings to consider the string (z, w_1, \dots, w_m) as the state of the system. The rate-independence feature allows us, at least in some cases, to take into account a sort of phase-portrait of the evolution $t \mapsto (z(t), w_j(t))$ in the space-state, and this is somehow helpful.

The controllability problem for (1.1) we are addressing, consists in finding, for any given point $B \in \mathbb{R}^n$, a control $u = (u_1, \dots, u_m)$ such that the state z satisfies $z(T) = B$.

In the case without hysteresis, that is

$$\begin{cases} z'(t) = \sum_{j=1}^m g_j(z(t)) u_j(t), \\ z(0) = A, \end{cases} \quad (1.2)$$

a well-known sufficient condition for the controllability, in the case $U_j = \mathbb{R}$, (see, e.g., [2, 10]) is the fact that the m smooth fields $g_j : \mathbb{R}^n \rightarrow \mathbb{R}^n$ are full generating, that is the Lie algebra generated by them has dimension n , i.e., the dimension of the state-space. We recall that, given two fields $f, g : \mathbb{R}^n \rightarrow \mathbb{R}^n$ their Lie brackets in the point $x \in \mathbb{R}^n$ is defined as the field

$$[f, g] : x \mapsto [f, g](x) = D_g(x)f(x) - D_f(x)g(x),$$

where, for example, $D_g(x)$ stays for the Jacobian matrix of g evaluated at x . Hence, the request is that,

$$\begin{aligned} &\text{at any } x \in \mathbb{R}^n, \text{ the } m \text{ vectors } g_j(x), \\ &\text{together with all their iterated Lie brackets as, for example,} \\ &[[g_\alpha, g_\beta], g_\gamma](x), [[[g_\alpha, g_\beta], g_\gamma], g_\nu](x), [[g_\alpha, g_\beta], [g_\gamma, g_\nu]](x), \dots \\ &\text{generates } \mathbb{R}^n, \text{ that is they are } \textit{full generating}. \end{aligned} \quad (1.3)$$

In the case of presence of hysteresis (1.1), the application of the full generating controllability condition (1.3) is not evident. Indeed, the effective state of the system entering g_j is the pair (z, w_j) , and hence the condition should involve the derivatives of g_j with respect to w_j , but these are not helpful, because the evolution of w_j is not given by a differential equation, as the one involving z . The hysteretic evolution of w_j indeed is mostly given by some logic/thresholds conditions (as we will see in the next sections) where the fields g_j do not play an essential role. One might think to consider directly in (1.1) the equations $z' = g_j(z, \mathcal{G}_j[z, w_j^0]) =: \tilde{g}_j(z)$ and then impose the conditions to the fields \tilde{g}_j . But the nonlocal feature of the hysteresis (in particular the memory) drastically prevents from the use of this approach, giving no meaning to any possible definition of the fields $x \mapsto \tilde{g}_j(x)$ and of their derivatives.

In order to recover a full generating-like condition one may consider w_j as a parameter, that is require that,

$$\begin{aligned} &\forall j = 1, \dots, m \quad \forall w_j \in W_j \\ &\text{the } m \text{ fields on } \mathbb{R}^n : x \mapsto g_j(x, w_j) \text{ are full generating (see (1.3)).} \end{aligned} \quad (1.4)$$

Such a condition may be considered strong as well as weak: “strong” because it requires the full generating condition for all the possible values of the parameters w_j ; “weak” because w_j actually are not parameters but essential parts of the evolution of the system, and hence (1.4) does not really link with the time evolution feature of w_j (which is not given, but is part of the solution of the system). Moreover, the evolution $t \mapsto (z(t), w_j(t))$, being governed by the hysteresis effect represented by the operator \mathcal{G}_j , is likely to be subject to some state-constraints (see next sections), which may also bring some further difficulties.

In this paper we address the problem of the controllability of the system with hysteresis (1.1), under the condition (1.4).

One of the major contributions of the paper is the proof that, when the operators \mathcal{G}_j are scalar hysteresis operator of the so-called Play type, then the system is controllable. In proving this we use a suitable approximation of the operator and the subsequent passage to the limit.

The starting point is the result in Bagagiolo and Zoppello [8] proving that system (1.1) is controllable when the hysteresis operators \mathcal{G}_j are given by a finite weighted sum of delayed relays. A delayed relay is a suitable switching law between two values for the output subject to the evolution of the input (see next section). In particular the delay is not in time (i.e., in the sense that if one waits a sufficiently large time, then the switch of the output occurs), but it is instead “in space”: The switch occurs if the input reaches some fixed thresholds (which is for some aspects the core of hysteresis, linked to the persistence of the effect until something “changes”). It is exactly such a sort of delayed in the switches that, in Bagagiolo and Zoppello [8], allows to divide the state space in a finite number of regions where the switches do not occur (and hence the values w_j are constant) until the pair (z, w_j) leaves the region. Inside those regions, condition (1.4) gives the controllability of the system and hence, gluing together the pieces of controlled trajectories inside the regions, the global controllability result is then obtained.

The finiteness of the number of those regions (that is the finiteness of the number of the weighted relays) played of course a fundamental role in the proof of the result in [8]. When the hysteresis relationship is not given by a finite sum of switching hysteresis, as the delayed relays are, but instead is given by a continuous hysteresis (i.e., the output is a continuous function of time) then, under condition (1.4), the technique of [8] is no more applicable, because there is not an a-priori possible subdivision of the state-space into a finite number of regions where the output remains constant.

One of the most widely used hysteresis operators for describing continuous hysteresis phenomena from the applications, is the so-called Play operator. In [8], it is suggested that the Play operator may be probably seen as a suitable limit of operators given by weighted sum of delayed relays, when the number of such relays goes to infinity. The present paper definitely addresses such a question proving that the claim is true. Hence, thus one can pass to the limit in the controllability problems for the approximating systems with the finite sum of relays, and get a controllability result for the limit system with the Play. In particular this is obtained by establishing uniform bounds for the controls. We then actually have to address two problems, both of independent interest.

First problem. We prove that, in a suitable functional space, the Play operator is the limit of a suitable sequence of hysteresis operators \mathcal{G}^k , given by a weighted sum of k delayed relays, when $k \rightarrow +\infty$. This idea is probably already latent in the mathematical literature for the hysteresis operator (see [9, 16, 28]), but its precise formulation (in particular in which sense such a limit occurs), the right exhibition of the approximating operators \mathcal{G}^k , and the rigorous proof, is probably missing in the

literature. To fill this gap we report here two possible proofs of the convergence of this approximation, one more “graphical and combinatorial”, the other one more “functional analytic”. We believe that this result is new and interesting by itself, independently from the controllability problem, and that it gives an independent relevance to the paper.

Second problem. The passage to the limit in the controllability problems for the systems, indexed by k ,

$$\begin{cases} z'(t) = \sum_{j=1}^m g_j(z(t), w_j(t)) u_j(t), \\ w_j(t) = \mathcal{G}_j^k[z, w_j^0](t), \quad \forall j = 1, \dots, m, \\ z(0) = A, \end{cases} \quad (1.5)$$

where \mathcal{G}_j^k is the sum of n delayed relays converging to a Play operator \mathcal{G}_j , as $k \rightarrow +\infty$. Passing to the limit in k , in particular being able to control the possible fast oscillations of the controls, and by using the “first problem” above, we can get a controllability result for (1.1) when \mathcal{G}_j are Play operators.

The control of the oscillations of u^k when $k \rightarrow +\infty$, is possible by virtue of the peculiarity of the Play operator.

The delayed relay and the Play are scalar hysteresis operators, that is both input and output are time dependent scalar quantities (indeed, in the next sections, both in (1.1) and in (1.5) we will introduce, in the hysteresis operators $\mathcal{G}_j, \mathcal{G}_j^k$, a fixed component $z \cdot \xi_j$ of z as input). The generalization of the scalar hysteresis operators to vectorial hysteresis (that is input and output both vectorial quantities) is not always evident and even not possible. However, the Play operator has a rather natural extension to the vectorial case which is connects to the so-called sweeping process in \mathbb{R}^n . In this paper we then consider also a third problem.

A perspective third problem. One further question may concern the controllability of (1.1) when the hysteresis operators \mathcal{G}_j are given by the sweeping process in \mathbb{R}^n (cf. Moreau [22]). In some cases, the sweeping process can be seen as suitably linking together the evolution of a point in \mathbb{R}^n (the input) with the evolution of another point in \mathbb{R}^n (the output), and such relationship is determined by the evolution of a convex subset of \mathbb{R}^n . The scalar Play operator can be seen as a sweeping process in dimension one. We address the problem whether for the sweeping process we can also identify some basic elements (as the delayed relays for the Play), in order to study first the controllability for the system with such basic elements, and then perform a passage to the limit.

Another interesting extension could certainly be to the case of Preisach hysteresis. The use made in this paper of the geometrical evolution inside the Preisach plane is promising in that direction. However, we do not treat here such an argument and we leave it for possible future studies.

We note that some generalizations of the aforementioned full generating condition (1.3) has been studied for the case of switched systems [23] and of non-smooth fields [11,24]. Moreover, the so-called small time controllability is studied for a state-dependent switching linear system in [15]. However, in those works, the possible non-local feature, as in the hysteresis case, is not taken into account. The latter indeed seems in the framework of controllability, a rather new subject with many potential applications. In this regard, we have to say that some of the authors have studied optimal control and differential games for systems with Play and switching hysteretic memory, in the framework of dynamic programming method and Hamilton-Jacobi equations (see, e.g., [3,5,7]).

Possible motivations to study the controllability of systems with hysteresis as (1.1) can be seen, for example, in the treatment of perturbation of systems without hysteresis (1.2) when a sort of damage occurs in the mechanical realization of a feedback law, see Visintin [28] (for damage and hysteresis), Tarbouriech et al. [27] (for feedback law and hysteresis), and the comments in Bagagiolo and Zoppello [8, Remark 4.14]. In the same remark in [8] the controllability condition (1.4) is also further commented and justified. Moreover, inserting hysteresis in controllability problems may sometimes help in bypassing possible obstructions for movement in the model (see Bagagiolo et al. [6]). For the sake of completeness, we report here one of the motivating example in [8]. Let us consider the system (without hysteresis)

$$\dot{z} = \sum_{j=1}^m \tilde{g}_j(z) u_j. \quad (1.6)$$

Due for example to a damage, in the real applications one does not exactly face the system without hysteresis (1.2), but a perturbation of it of the form

$$\dot{z} = \sum_{j=1}^m (\tilde{g}_j(z) + f_j(w_j)) u_j,$$

where w_j is the output of a hysteresis operator applied to z , and $f_j : \mathbb{R} \rightarrow \mathbb{R}^n$. This can be seen as a generalization of a linear system with feedback control which is affected by some damage (see Tarbouriech et al. [27] and Visintin [28] for more details on damaged systems and hysteresis). When system (1.6) is controllable, that is the fields \tilde{g}_j satisfy (1.3), then, if the perturbation f_j is sufficiently small, the presence of the hysteretic term does not affect the controllability of the “non-perturbed” part, that is the fields $g_j(z, w) = \tilde{g}_j(z) + f_j(w)$ satisfy (1.4).

As general reference on mathematical models of hysteresis, besides the already quoted book [28], we also refer to the books [9, 14, 16, 20, 21].

As already pointed out, we finally remark that our approach is promising for generalizations to the Preisach operator, to the sweeping process and also to some special cases of controllability for partial differential equations with hysteresis (see Bagagiolo [4] and Gavioli and Krejčí [12] for other approaches). However, the study of such problems is not addressed yet.

The paper is structured as follows. In Section 2 we give a general definition of hysteresis operators and present those examples which are relevant for our problem. In Section 3 we formalize and study in a functional setting the approximation of the Play operators by a finite weighted sum of delayed relay. In Section 4 we pose the controllability problem for the system with Play-type hysteresis and prove the corresponding major results. In Section 5, in the spirit of Section 3, we address, in a particular case, the problem of the approximation of the sweeping process by weighted sums of other simpler fundamental elements. A conclusive section ends this paper.

2. The hysteresis operators in this paper

Hysteresis is a quite common phenomenon in many situations from the applied science as in physics, engineering, biology, and others. It may appear when the evolution of one of the quantities under observation, w , is subject to the evolution of another quantity z via the whole past history of z itself.

A characteristic property of the memory behavior of hysteresis is that it is independent on how fast z has run its history, but only depends on the sequence of values reaches by z along its history. In other words, it is independent from time-scaling, and this fact makes hysteresis quite different from other memory mathematical models because in general it cannot be represented by a convolution operator. On the other side, such time-scaling independence (called rate-independence) may be helpful because permits to draw pictures of the hysteretic evolution in the state-space as a sort of phase-portrait.

2.1. A general definition for scalar hysteresis operators

Let $T > 0$ be a fixed finite horizon, X be a suitable space of functions from $[0, T]$ to \mathbb{R} and \mathcal{D} be a suitable subset of $C([0, T]) \times \mathbb{R}$. We say that an operator

$$\mathcal{F} : \mathcal{D} \rightarrow X,$$

$$(z, w_0) \mapsto \mathcal{F}[z, w^0],$$

is a hysteresis operator (we use the notation $\mathcal{F}[z, w^0](t)$ for the image in \mathbb{R} of $t \in [0, T]$ via the function $\mathcal{F}[z, w^0] \in X$) if for all $t \in [0, T]$ the following two properties hold:

i) rate independence:

$$\mathcal{F}[z \circ \varphi, w^0](t) = \mathcal{F}[z, w^0](\varphi(t)), \quad \forall \varphi : [0, T] \rightarrow [0, T]$$

non-decreasing, surjective, such that

$$(z \circ \varphi, w^0) \in \mathcal{D} \text{ whenever } (z, w^0) \in \mathcal{D}, \quad (2.1)$$

ii) causality:

$$\mathcal{F}[z_1, w^0](t) = \mathcal{F}[z_2, w^0](t), \quad \forall (z_1, w^0), (z_2, w^0) \in \mathcal{D}$$

such that $z_1 = z_2$ on $[0, t]$.

Here, $z(\cdot)$ is the input and $w(\cdot) = \mathcal{F}[z, w^0](\cdot)$ is the output. The presence in the domain of \mathcal{F} of the initial state $w \in \mathbb{R}$ for the output is due to the fact that we also require that $\mathcal{F}[z, w^0](0) = w$.

Another important property often satisfied by hysteresis operators is

$$\begin{aligned} \text{semigroup property: } & \mathcal{F}[z(\cdot + t), \mathcal{F}[z, w^0](t)](\tau) = \mathcal{F}[z, w^0](t + \tau), \\ & \forall (z, w^0) \in \mathcal{D}, \quad \forall t, \tau \in [0, T] \text{ such that } t + \tau \in [0, T]. \end{aligned} \quad (2.2)$$

If X is also a normed space, with norm $\|\cdot\|_X$, many hysteresis operators are Lipschitz continuous: there exists $L > 0$ such that

$$\begin{aligned} \|\mathcal{F}[z_1, w^1] - \mathcal{F}[z_2, w^2]\|_X & \leq L(\|z_1 - z_2\|_\infty + |w^1 - w^2|), \\ \forall (z_1, w^1), (z_2, w^2) & \in \mathcal{D}. \end{aligned} \quad (2.3)$$

A typical picture (phase-portrait) of a hysteresis input-output relationship with its hysteresis cycles is given in Figure 1.

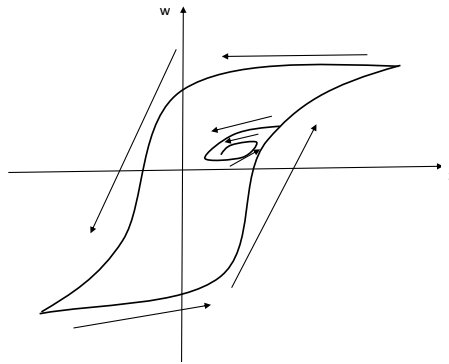

Figure 1. A typical hysteresis cycle.

2.2. The delayed relay

This is the simplest scalar hysteresis operator and it represents a discontinuous hysteresis, in the sense that the output is a possibly discontinuous function of time taking values in $\{-1, 1\}$. Given two thresholds $\rho_1, \rho_2 \in \mathbb{R}$ with $\rho_1 < \rho_2$ and denoting by $\rho = (\rho_1, \rho_2)$ the pair of thresholds, the delayed relay operator $h_\rho : \mathcal{D} \rightarrow X$, $(z, w^0) \mapsto h_\rho[z, w^0]$ is defined by the following three statements:

- 1) $\mathcal{D} = \{(z, w^0) \in C([0, T]) \times \mathbb{R} \mid w^0 = -1 \text{ if } z(0) \leq \rho_1, \\ w^0 \in \{-1, 1\} \text{ if } \rho_1 < z(0) < \rho_2, w^0 = 1 \text{ if } z(0) \geq \rho_2\}$;
- 2) $X = L^\infty(0, T)$;
- 3) $h_\rho[z, w_0](t) = \begin{cases} w_0, & \text{if } E_t := \{\tau \in [0, t] \mid z(\tau) \leq \rho_1 \text{ or } z(\tau) \geq \rho_2\} = \emptyset, \\ -1, & \text{if } E_t \neq \emptyset \text{ and } z(\max E_t) \leq \rho_1, \\ 1, & \text{if } E_t \neq \emptyset \text{ and } z(\max E_t) \geq \rho_2. \end{cases}$

The hysteresis cycle of the delayed relay is represented in Figure 2. Roughly speaking, if $z(t) \leq \rho_1$ then necessarily $w(t) = -1$, if $z(t) \geq \rho_2$ then necessarily $w(t) = +1$, if $\rho_1 < z(t) < \rho_2$ then the value of $w(\cdot)$ depends on the past history (looking to Figure 2, the pair $(z(t), w(t))$ does not leave the filled branch where it is, until the threshold is possibly reached). The delayed operator is a hysteresis operator in the sense of Section 2.1 and satisfies the semigroup property.

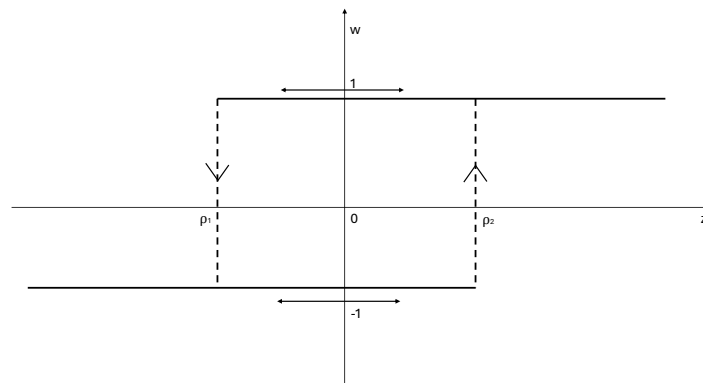

Figure 2. The hysteresis cycle of the delayed relay.

2.3. The Play operator

This is an important example of scalar continuous hysteresis (in the sense that the output is a continuous function of time). Given a “semi-amplitude” $a > 0$ we consider the strip in \mathbb{R}^2

$$\Omega_a = \{(z, w^0) \in \mathbb{R}^2 \mid -a + z < w^0 < a + z\}$$

and we denote by $\overline{\Omega}_a$ its closure. The Play operator \mathcal{P} is defined by the following three statements:

- 1) $\mathcal{D} = \{(z, w^0) \in C([0, T]) \times \mathbb{R} \mid (z(0), w^0) \in \overline{\Omega}_a\}$;
- 2) $X = C([0, T])$;
- 3) if $z \in W^{1,1}(0, T)$ then $w = \mathcal{P}[z, w^0]$ is the unique function in $W^{1,1}(0, T)$ such that $(z(t), w(t)) \in \overline{\Omega}_a$ for every $t \in [0, T]$, and satisfying the variational inequality $w'(t)(w(t) - z(t) + v) \leq 0$ for all $v \in [-a, a]$ and for almost all $t \in [0, T]$.

In 3) the existence and uniqueness of such a function $w(\cdot) \in W^{1,1}(0, T)$ is guaranteed by standard results for differential variational inequality, then, by density, the definition can be extended to input functions $z \in C([0, T])$ (see Visintin [28]), however note that, in our controllability problem, z is the solution of a system of ODE and hence belongs to $W^{1,1}(0, T)$. The hysteresis cycle of the Play operator is represented in Figure 3. Roughly speaking, if $(z(t), w(t)) \in \Omega_a$ then $w(\cdot)$ stays constant (inside the open strip we can only move horizontally); if $w(t) = z(t) - a$ (i.e we are on the right boundary of the strip) and $z(\cdot)$ increases then we move along that boundary, and if $z(\cdot)$ is decreasing then we enter the strip horizontally; similar considerations hold if $w(t) = z(t) + a$ that is we are on the left boundary of the strip. In any case, the pair $(z(t), w(t))$ cannot leave the closed strip $\overline{\Omega}_a$.

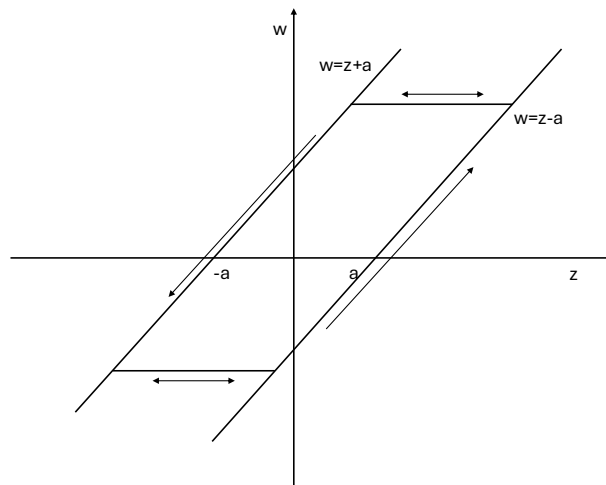

Figure 3. The hysteresis cycle of the Play operator.

The Play operator is a Lipschitz continuous hysteresis operator and satisfies the semigroup property (cf. Visintin [28]). Moreover it maps \mathcal{D} into the space of functions of bounded variation on $[0, T]$, and for $z \in C([0, T])$, $w = \mathcal{P}[z, w^0]$ is characterized by the Stieltjes-integral variational inequality (cf.

Krejčí [17, Corollary 2.3])

$$\int_0^T (w(t) - z(t) + v(t))dw(t) \leq 0 \quad \forall v \in C([0, T]; [-a, a]).$$

2.4. The truncated Play operator

Let \mathcal{P} denote the Play operator with “semi-amplitude” $a > 0$, and let the truncated Play be defined as

$$\mathcal{TP} : C([0, T]) \times \mathbb{R} \rightarrow C([0, T]), \quad (z, w) \mapsto \mathcal{F}[z, w^0](t) := \mathcal{T}(\mathcal{P}[z, w^0](t)),$$

where \mathcal{T} is the truncation function

$$\mathcal{T}(\xi) = \begin{cases} \xi, & \text{if } -1/2 \leq \xi \leq 1/2, \\ 1/2, & \text{if } \xi \geq 1/2, \\ -1/2, & \text{if } \xi \leq -1/2. \end{cases}$$

The choice of the truncation value $1/2$ is motivated by coherence with formula (3.1) below. Of course other choices are possible. The hysteresis cycle of the truncated Play is represented in Figure 4.

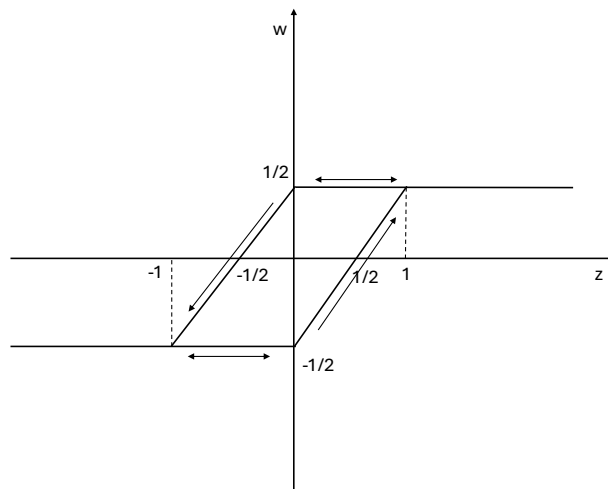

Figure 4. The hysteresis cycle of the truncated Play operator.

2.5. The Preisach operator

The delayed relay operator h_ρ defined in Subsection 2.2 is uniquely identified by the pair of thresholds $\rho = (\rho_1, \rho_2)$ with $\rho_1 < \rho_2$. We then define the so-called Preisach plane

$$\Pi = \left\{ \rho = (\rho_1, \rho_2) \in \mathbb{R}^2 \mid \rho_1 < \rho_2 \right\},$$

so that there is a bijection between the set of all delayed relays and the points of the Preisach plane Π .

The output w of Preisach operator of hysteresis is defined, for a scalar input z , as a weighted average of delayed relays with the same input z and a given initial output. It can be written, for any time t , as

$$w(t) = \int_{\Pi} h_{\rho}[z, \xi(\rho)](t) d\mu,$$

where the measurable function $\xi : \Pi \rightarrow \{-1, 1\}$ gives the initial output of the delayed relay h_{ρ} , and the Borel measure μ on Π , with $\mu(\Pi) < +\infty$, is given. We denote by \mathcal{H}_{μ} the Preisach operator which acts between a domain $\mathcal{D} \subseteq C([0, T]) \times \Xi$ and \mathcal{X} , where Ξ is the set of the Borel functions on Π taking values in $\{-1, 1\}$ and \mathcal{X} stays for a space of scalar time-dependent functions.

The Preisach operator is a hysteresis operator satisfying the semigroup property. The evolution of the output $w = \mathcal{H}_{\mu}[z, \xi]$ can be characterized by a useful geometrical interpretation.

We denote by $\tilde{\mathcal{S}}$ the set of maximal anti-monotone graphs S on the Preisach plane. We suppose that, under the evolution of the input z , at some instant $t \in [0, T]$ there exists a maximal anti-monotone graph $S(t) \in \tilde{\mathcal{S}}$ such that the relays corresponding to points $\rho \in \Pi$ below $S(t)$ (respectively, above $S(t)$) have output 1 (respectively, -1). Writing

$$A^+(t) = \left\{ \rho \in \Pi \mid h_{\rho}[z, \xi(\rho)](t) = 1 \right\},$$

$$A^-(t) = \left\{ \rho \in \Pi \mid h_{\rho}[z, \xi(\rho)](t) = -1 \right\},$$

it is $w(t) = \mathcal{H}_{\mu}[z, \xi](t) = \mu(A^+(t)) - \mu(A^-(t))$ and $S(t) = \partial A^+(t) \cap \partial A^-(t)$. Hence, the evolution of the output w is linked to the evolutions of the sets A^+ and A^- . For $\tau > t$, the evolutions of those sets are strongly linked to the evolution of the maximal anti-monotone graph $\tau \mapsto S(\tau) \in \tilde{\mathcal{S}}$. In particular, when the input z increases, the graph S modifies by the emerging of an upward moving horizontal segment in its final part (the one linked to the boundary of Π , $\{\rho \mid \rho_1 = \rho_2\}$) and, when z decreases, a similar leftward moving vertical segment is formed.

If we suppose that evolution starts, at time $t = 0$, from the “virgin state” represented by the graph

$$S^v := \{(\rho_1, \rho_2) \mid \rho_2 = -\rho_1 < 0\} \in \tilde{\mathcal{S}},$$

then every graph $S(t)$ is the union of an at most countable family of vertical and horizontal alternating segments possibly accumulating on the point $(z(t), z(t))$ and coincides with the virgin state outside of a compact set, see Figure 5. We denote $\mathcal{S} \subseteq \tilde{\mathcal{S}}$ the set of such graphs and we endow it by a metric structure by the distance

$$d(S', S'') := \int_{\Pi} |\xi_{S'} - \xi_{S''}| d\rho, \tag{2.4}$$

where $d\rho$ is the Lebesgue measure on Π and, for $S \in \mathcal{S}$, $\xi_S \in L^{\infty}(\Pi)$ is the function, taking values in $\{-1, 1\}$ defined by $\xi_S(\rho_1, \rho_2) := 1$ if $\rho_2 < s_1$ for every $s_1 \in S(\rho_1)$, and $\xi_S(\rho_1, \rho_2) := -1$ if $\rho_2 > s_2$ for every $s_2 \in S(\rho_1)$.

We refer to Paragraph IV.2 in Visintin [28] for more details on the evolution of the graphs S and related results. Some specific results are going to be given in Section 3.

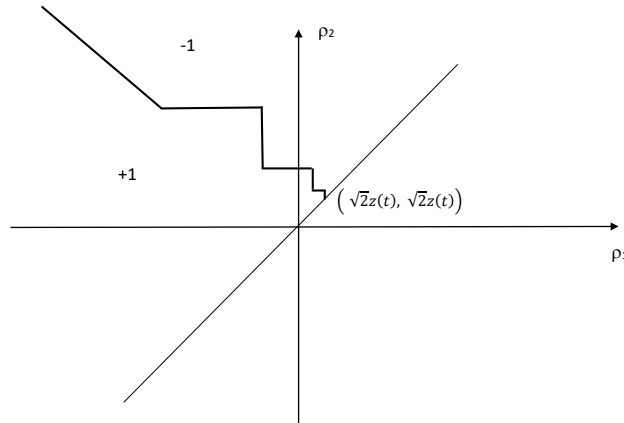

Figure 5. A maximal anti-monotone graph $S \in \mathcal{S}$.

3. The Play model and its approximation by relays

The result in this section starts by the consideration that the truncated Play operator \mathcal{TP} with semi-amplitude $1/2$ can be written as the following super-position of relays (see Bagagiolo and Zoppello [8] and [9, Remark 2.1.3]):

$$\mathcal{TP}[z, w^0](t) = \frac{1}{2} \int_0^1 h_r[z, w_r^0](t) dr, \tag{3.1}$$

where we use the notation h_r for the relay with thresholds $(-1 + r, r)$ with $r \in [-1, 1]$, and where the initial outputs $w_r^0 = h_r(z, w_r^0)(0)$ are given by an initial distribution of the relays of the form:

$$w_r^0 = \begin{cases} 1 & \text{for } 0 \leq r \leq \bar{r}, \\ -1 & \text{for } \bar{r} < r \leq 1, \end{cases} \tag{3.2}$$

for some $\bar{r} \in [-1, 1]$. This fact will be used in the following paragraph (see also Figure 6). The representation (3.1) shows that the relays whose possible switches give the evolution of \mathcal{TP} are just the relays with thresholds (ρ_1, ρ_2) on the segment $L = \{(\rho_1, \rho_2) \mid -1 \leq \rho_1 \leq 0, \rho_2 = 1 + \rho_1\}$.

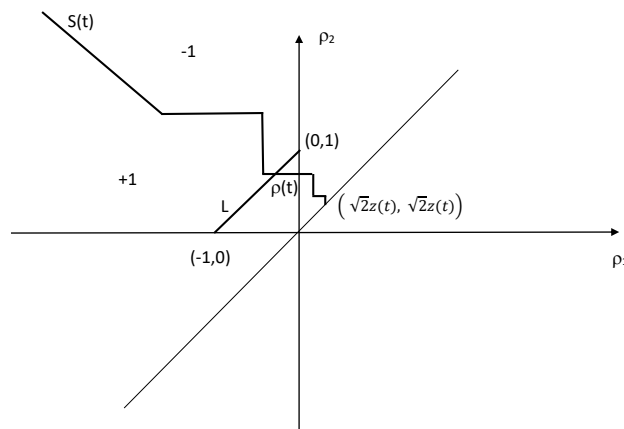

Figure 6. Intersection $S(t) \cap L$.

In [8], the truncated Play operator \mathcal{TP} , with semi-amplitude $a = 1/2$, is substituted by the following superposition of $k \in \mathbb{N} \setminus \{0\}$ relays in parallel:

$$W_k : (z, w^0) \mapsto W_k[z, w^0](\cdot) := \frac{1}{2k} \sum_{i=1}^k h_i^k[z, w_{ik}^0](\cdot), \quad (3.3)$$

where the shorthand h_i^k denotes the relay with pair of thresholds $(-1 + i/k, i/k)$, $\bar{i}_k \in \{1, \dots, k\}$ is the largest index such that $-1 + \bar{i}_k/k \leq -1 + \bar{r}$, and we assume that $w_{ik}^0 = 1$ if $i < \bar{i}_k$, $w_{ik}^0 = -1$ if $i > \bar{i}_k$. For simplicity in the sequel we will denote the initial data w_{ik}^0 and w_r^0 simply by w^0 .

In the following two subsections we give two proofs of the convergence of W_k to the truncated play \mathcal{TP} as $k \rightarrow +\infty$.

In the following two subsections we are going to provide two proofs of the following result:

Theorem 3.1. *Assume that $z_k, z \in C([0, T])$, $z_k(0) = z(0)$ for every k , and that $z_k(t) \rightarrow z(t)$ as $k \rightarrow \infty$, for every $t \in [0, T]$. Then*

$$W_k[z_k, w^0](t) \rightarrow \mathcal{TP}[z, w^0](t) \text{ for every } t \in [0, T]. \quad (3.4)$$

If in addition we assume that $z_k \rightarrow z$ uniformly on $[0, T]$, then the convergence in (3.4) is uniform on $[0, T]$.

3.1. Approximation by relays I

Before giving the first proof we recall that given a function $z : [0, T] \rightarrow \mathbb{R}$, and an anti-monotone graph $S^0 \in \mathcal{S}$ on the Preisach plane Π , we say that S^0 is *compatible* with z as initial state, if

$$S^0 \cap \{\rho \in \Pi : \rho_1 = \rho_2\} = \{(z(0), z(0))\}.$$

Referring to Visintin [28], we also recall the following result.

Theorem 3.2. *Let $S^0 \in \mathcal{S}$ be fixed, z_k be uniformly converging to z on $[0, T]$ and, for all k , $z_k(0) = z(0)$ be compatible with S^0 . Then, the corresponding sequence of the evolution of the graphs $t \mapsto S_k(t)$ uniformly converges on $[0, T]$ to the corresponding limit evolution $t \mapsto S(t)$, for the metrics (2.4) on \mathcal{S} .*

First proof of Theorem 3.1. Due to the anti-monotone nature of the graphs $S \in \mathcal{S}$, for every $t \in [0, T]$ there exists at most one point in the intersection $S(t) \cap L$. We then denote by $\rho(t) = (\rho_1(t), \rho_2(t))$ such a point, when it exists, otherwise we put, respectively, $\rho(t) = (0, 1)$ if the intersection is empty and L stays below $S(t)$, and $\rho(t) = (-1, 0)$ if the intersection is empty and L stays above $S(t)$, see Figure 6.

Hence, denoting by $\| [P_1, P_2] \|$ the length of a segment on the plane with extremal points P_1 and P_2 , then it is

$$\mathcal{TP}[z, w^0](t) = \frac{\| [(-1, 0), \rho(t)] \| - \| [\rho(t), (0, 1)] \|}{2\sqrt{2}}. \quad (3.5)$$

Also note that it must be $w^0 = \frac{\| [(-1, 0), \rho(0)] \| - \| [\rho(0), (0, 1)] \|}{\sqrt{2}}$, and hence $\rho(0)$ is uniquely determined by w^0 . This means that the initial output does not depend on the whole initial graph $S^0 \in \mathcal{S}$ but only on $S^0 \cap L$.

Now we consider the approximation (3.3), with $k \in \mathbb{N} \setminus \{0\}$ fixed. The relays h_i^k correspond to points $\rho^i(k) = (\rho_1^i(k), \rho_2^i(k)) = (-1 + i/k, i/k)$ on L which are equi-distributed with step $\sqrt{2}/k$ and such that $\rho^k(k) = (0, 1)$. We denote by R_k the set of such points.

Given an input evolution z on $[0, T]$, and a compatible initial output w^0 (that is w^0 uniquely determines $\rho(0) = S^0 \cap L$ with S^0 compatible with z), at every $t \in [0, T]$ it is

$$2W_k[z, w^0](t) = \begin{cases} \frac{\#(R_k \cap [(-1, 0), \rho(t)]) - \#(R_k \cap [\rho(t), (0, 1)])}{k}, & \text{if } \rho(t) \notin R_k, \\ \frac{\#(R_k \cap [(-1, 0), \rho(t)]) - \#(R_k \cap [\rho(t), (0, 1)]) + 1}{k}, & \text{if } \rho(t) \in R_k \text{ and } h_{\rho(t)}[z, w^0](t) = 1, \\ \frac{\#(R_k \cap [(-1, 0), \rho(t)]) - \#(R_k \cap [\rho(t), (0, 1)]) - 1}{k}, & \text{if } \rho(t) \in R_k \text{ and } h_{\rho(t)}[z, w^0](t) = -1, \end{cases} \quad (3.6)$$

where, for a finite set A , $\#A$ is its cardinality. Note that $h_{\rho(t)}[z, w^0](t) = 1$ if the intersection $\rho(t) = S(t) \cap L$ is with a horizontal segment of $S(t)$, it is -1 if the intersection is with a vertical segment. If instead, the intersection is inside the virgin region of $S(t)$ (with the bisector: $\rho_1 = -\rho_2$, $\rho_1 < 0$), then the value of $h_{\rho(t)}[z, w^0](t)$ is determined by w^0 .

We then have, for all $t \in [0, T]$,

$$W_k[z, w^0](t) = \frac{\#(R_k \cap [(-1, 0), \rho(t)]) - \#(R_k \cap [\rho(t), (0, 1)])}{2k} + \mathcal{O}(k), \quad (3.7)$$

where $|\mathcal{O}(k)| \leq 1/k \rightarrow 0$ as $k \rightarrow +\infty$, independently from $t \in [0, T]$.

We first prove the point-wise convergence. For every k , we denote the corresponding $\rho(t)$ by $\rho(t, k)$ and use the notation $\rho(t)$ for the corresponding point for the limit input z . By Theorem 3.2, it is, for all $t \in [0, T]$, $\rho(t, k) \rightarrow \rho(t)$ as $k \rightarrow +\infty$. By construction, it is, for every step k ,

$$\begin{aligned} \#(R_k \cap [(-1, 0), \rho(t, k)]) &= \max\{i = 1, \dots, k \mid \rho^i(k) \in [(-1, 0), \rho(t, k)]\}, \\ \#(R_k \cap [\rho(t, k), (0, 1)]) &= k - \min\{i = 1, \dots, k \mid \rho^i(k) \in [\rho(t, k), (0, 1)]\} + 1, \end{aligned}$$

where the maximum is equal to 0 if the set is empty.

Since the step of the pairs of thresholds $\rho^i(k)$ is $\sqrt{2}/k$, we then have

$$\begin{aligned} \#(R_k \cap [(-1, 0), \rho(t, k)]) &= \left\lfloor \frac{k \lfloor [(-1, 0), \rho(t, k)] \rfloor}{\sqrt{2}} \right\rfloor, \\ \#(R_k \cap [\rho(t, k), (0, 1)]) &= \left\lfloor \frac{k \lfloor [\rho(t, k), (0, 1)] \rfloor}{\sqrt{2}} \right\rfloor + 1, \end{aligned}$$

where, for a real number $\xi \in \mathbb{R}$, $\lfloor \xi \rfloor$ is its integer part. By the convergence of $\rho(t, k)$, it is

$$\begin{aligned} \lfloor [(-1, 0), \rho(t, k)] \rfloor &\rightarrow \lfloor [(-1, 0), \rho(t)] \rfloor, \\ \lfloor [\rho(t, k), (0, 1)] \rfloor &\rightarrow \lfloor [\rho(t), (0, 1)] \rfloor, \end{aligned} \quad (3.8)$$

and hence (note that, for all $\xi \in \mathbb{R}$, $\lfloor k\xi \rfloor/k \rightarrow \xi$ as $k \rightarrow +\infty$),

$$\begin{aligned} \frac{1}{k} \left[\frac{k|[-1, 0), \rho(t, k)|}{\sqrt{2}} \right] &\rightarrow \frac{|[-1, 0), \rho(t)|}{\sqrt{2}}, \\ \frac{1}{k} \left[\frac{k|[\rho(t, k), (0, 1)]|}{\sqrt{2}} \right] &\rightarrow \frac{|[\rho(t), (0, 1)]|}{\sqrt{2}}, \end{aligned} \quad (3.9)$$

from which the conclusion: (3.7) point-wise converges to (3.5).

By Theorem 3.2, we also have that $\rho(\cdot, k)$ uniformly converges to $\rho(\cdot)$ on $[0, T]$. This implies that the convergences (3.8) and (3.9) are also uniform in time, which concludes the proof, being the possible discrepancies between the lines in (3.6) of amplitude at most $2/k$. \square

3.2. Approximation by relays II

We provide here the second proof.

Second proof of Theorem 3.1. For every $k \in \mathbb{N} \setminus \{0\}$ let μ_k be the Borel measure on Π defined by

$$\mu_k := \frac{1}{k} \sum_{i=1}^k \delta_{(-1+i/k, i/k)},$$

$\delta_{(-1+i/k, i/k)}$ being the Dirac delta concentrated at $(-1 + i/k, i/k)$. Therefore

$$W_k[\zeta, w^0](t) = \frac{1}{2} \int_{\Pi} h_{\rho}[\zeta, w_{\rho_2}^0](t) d\mu_k(\rho),$$

whenever (ζ, w^0) is in the domain of W_k , where we recall that h_{ρ} is the relay operator with thresholds $\rho = (\rho_1, \rho_2) \in \Pi$, and $w_{\rho_2}^0$ is defined as in (3.2) (but in the sequel for simplicity we will only write w^0). Now let us denote by δ_L the probability measure on Π concentrated on L defined by $\delta_L(B) := 2^{-1/2} \mathcal{H}^1(B \cap L)$ for every Borel set $B \subseteq \Pi$, where \mathcal{H}^1 is the 1-dimensional Hausdorff measure in \mathbb{R}^2 . For every $\varphi \in C_c(\Pi)$ we have that

$$\begin{aligned} \lim_{k \rightarrow \infty} \int_{\Pi} \varphi d\mu_k &= \lim_{k \rightarrow \infty} \frac{1}{k} \sum_{i=1}^k \varphi(-1 + i/k, i/k) \\ &= \int_0^1 \varphi(-1 + r, r) dr = \int_{\Pi} \varphi d\delta_L, \end{aligned}$$

i.e., $\mu_k \rightarrow \delta_L$ weakly star in the sense of measures (cf. Ambrosio et al. [1]). Now fix $z \in C([0, T])$, $t \in [0, T]$, and w^0 in \mathbb{R} such that (3.2) holds for some $\bar{r} \in [-1, 1]$. Then the discontinuity set J_t of the function $\rho \mapsto h_{\rho}(z, w^0)(t)$ intersects the line segment L exactly at one point, thus $\delta_L(J_t) = 0$, therefore by a theorem on the weak convergence of measures (cf. Recupero [25, Proposition A.4]) we have that

$$\begin{aligned} \lim_{k \rightarrow \infty} W_k[z, w^0](t) &= \lim_{k \rightarrow \infty} \frac{1}{2} \int_{\Pi} h_{\rho}[z, w^0](t) d\mu_k(\rho) = \frac{1}{2} \int_{\Pi} h_{\rho}[z, w^0](t) d\delta_L(\rho) \\ &= \frac{1}{2} \int_0^1 h_r[z, w^0](t) dr = \mathcal{TP}[z, w^0](t). \end{aligned} \quad (3.10)$$

Now, t being still fixed, assume that $z(t) \in (-1, 1]$, and let $i_k, j_k \in \{0, \dots, k\}$ be such that

$$-1 + i_k/k \leq z(t) < -1 + (i_k + 1)/k$$

and

$$-1 + j_k/k \leq z_k(t) < -1 + (j_k + 1)/k.$$

It follows that

$$\lim_k(-1 + i_k/k) = \lim_k(-1 + j_k/k) = z(t),$$

therefore $|j_k - i_k|/k \rightarrow 0$ as $k \rightarrow \infty$. On the other hand $|j_k - i_k|$ is the number of thresholds i which can be possibly switched by only one of the inputs $z_k(t)$ and $z(t)$ (i.e., $h_i^k(z, w^0)(t) \neq h_i^k(z_k, w^0)(t)$), therefore we have

$$\begin{aligned} & |W_k[z_k, w^0](t) - \mathcal{TP}[z, w^0](t)| \\ & \leq |W_k[z_k, w^0](t) - W_k[z, w^0](t)| + |W_k[z, w^0](t) - \mathcal{TP}[z, w^0](t)| \\ & \leq \frac{1}{2k} \sum_{i=1}^k |h_i^k[z_k, w^0] - h_i^k[z, w^0]| + |W_k[z, w^0](t) - \mathcal{TP}[z, w^0](t)| \\ & \leq \frac{|j_k - i_k|}{k} + |W_k[z, w^0](t) - \mathcal{TP}[z, w^0](t)|, \end{aligned} \quad (3.11)$$

which, together with (3.10), proves the pointwise convergence (the case when $z(t) \notin (-1, 1]$ is much easier). Now we address the uniform convergence. It is not restrictive to assume that $z(t) \in (-1, 1]$, thus, if $t \in [0, T]$, $k, p \in \mathbb{N} \setminus \{0\}$, then $z(t)$ belongs to $[-1 + i_p/(k+p), -1 + (i_p + 1)/(k+p)]$ and to $[-1 + i_k/k, -1 + (i_k + 1)/k]$ for suitable i_p and i_k . Hence if i is the number of thresholds which are possibly activated by $W_{k+p}[z, w^0](t)$ but not by $W_k[z, w^0](t)$, then we have $i/(k+p) \leq 1/k$, i.e., $i \leq (k+p)/p$, and we find

$$\begin{aligned} & |W_{k+p}[z, w^0](t) - W_k[z, w^0](t)| \\ & = \left| \frac{1}{2(k+p)} \sum_{i=1}^{k+p} h_i^{k+p}[z, w^0](t) - \frac{1}{2k} \sum_{i=1}^k h_i^k[z, w^0](t) \right| \\ & \leq \frac{1}{2(k+p)} \left(\frac{2(k+p)}{k} \right) = \frac{1}{k}, \end{aligned} \quad (3.12)$$

so that $W_k[z, w^0]$ is uniformly convergent to $\mathcal{TP}[z, w^0]$. On the other hand the uniform convergence of z_k to z implies that quantity $|j_k - i_k|$ in (3.11) is independent of t , so that (3.11) together with (3.12) yield the uniform convergence of $W_k[z_k, w^0]$ to $\mathcal{TP}[z, w^0]$. \square

Let us observe that from [28, Theorem 2.5] one can deduce the pointwise convergence of W_k under the assumption that $z_k \rightarrow z$ uniformly, a result which in our framework is weaker than Theorem 3.1.

4. The controllability result

Let g_1, \dots, g_m be C^∞ fields from $\mathbb{R} \times \mathbb{R}^n$ to \mathbb{R}^n , and ξ_1, \dots, ξ_m be unit vectors of \mathbb{R}^n . We consider the controlled dynamical system

$$\begin{cases} z' = \sum_{j=1}^m g_j(w_j, z)u_j, \\ w_j = \mathcal{G}[z \cdot \xi_j, w_j^0], \quad \forall j = 1, \dots, m, \\ z(0) = A, \end{cases} \quad (4.1)$$

where, \mathcal{G} is either the continuous truncated Play operator \mathcal{TP} (3.1) or its discrete approximation W_k (3.3), the controls u_j are $L^\infty(0, T)$ with $T > 0$ fixed, $A \in \mathbb{R}^n$ is fixed and $w^0 = (w_1^0, \dots, w_m^0) \in [-1/2, 1/2]^m$, the initial output, is compatible with the initial input A , that is each component w_j^0 corresponds to a graph $S_j^0 \in \mathcal{S}$ with $S_j^0 \cap \{\rho_1 = \rho_2\} = \{(A \cdot \xi_j, A \cdot \xi_j)\}$. In the sequel, we will refer to the above system as (4.1) $_{\mathcal{TP}}$ when $\mathcal{G} = \mathcal{TP}$, as (4.1) $_k$ when $\mathcal{G} = W_k$ and simply as (4.1) when no specification is needed.

Note that, even if the second member of (4.1) $_k$ may be discontinuous (due to the switching of the relays), the continuous trajectory exists anyway and it is constructed gluing together pieces of trajectories in the zones where no relay switches (indeed by hysteresis, and uniform continuity of those pieces of trajectories, there exists $\delta > 0$ such that after one switch of a relay, that relay cannot switch again before a lap of time δ).

The controllability problem for (4.1) is: Given any pair of points $A, B \in \mathbb{R}^n$, is there a control $u = (u_1, u_2, \dots, u_m)$ such that the corresponding solution satisfies $z(T) = B$? If the answer is “yes” for all T , then we say that the system is controllable. As usual, for the controllability, a crucial sufficient hypothesis is the so-called Lie Algebra Rank Condition (LARC) as stated in the famous Chow- Rashevskij theorem (see Agrachev and Sachkov [2]). In our setting we state it as follows:

$$\forall w \in [-1/2, 1/2]^m, \text{ the Lie algebra generated by the } m \text{ fields } g_1(w_1, \cdot), g_2(w_2, \cdot), \dots, g_m(w_m, \cdot) \text{ has maximal dimension } n \text{ for all } z. \quad (4.2)$$

Using Theorem 4.12 in [8], we have the following results:

Theorem 4.1. *If (4.2) holds, then, for all $k \in \mathbb{N} \setminus \{0\}$, (4.1) $_k$ is controllable.*

In particular, note that in Bagagiolo and Zoppello [8], for all k we get a control $u^k = (u_1^k, \dots, u_m^k)$ such that the corresponding solution (z^k, w^k) of (1.5) reaches the prescribed final target in a finite time. Since our control problem is linear in the controls and the sets of admissible controls are $U_j = \mathbb{R}$, it is possible to arrange the controls in order to accomplish the result in a time T fixed a priori. Let us note that such an observation also seems to lead to a possible further controllability result in the sense of the so-called small time controllability.

Here we prove the following results:

Theorem 4.2. *If (4.2) holds, then the system (4.1) $_{\mathcal{TP}}$ is controllable.*

Before proving this theorem, we need the following lemma:

Lemma 4.3. For any $A, B \in \mathbb{R}^n$, if (4.2) holds, the controls u_k that steer the system (4.1) $_k$ from A to B , whose existence is guaranteed by Theorem 4.1, may be taken as equibounded with respect to $k \in \mathbb{N} \setminus \{0\}$.

Proof. We start by proving the lemma in the case $n = 1$.

Let us consider the system with only one relay i.e., $k = 1$,

$$\begin{cases} \dot{z} = g(w, z)u, \\ w = h_1[z, w^0], \end{cases}$$

with $z : t \mapsto z(t) \in \mathbb{R}$, $g(w, \cdot) : \mathbb{R} \rightarrow \mathbb{R}$, $u \in L^\infty(0, T)$ and $h_1[z, w^0]$ the relay hysteresis operator, represented in Figure 7, with outputs $\{-1, 1\}$ and hence $w \in \{-1/2, 1/2\}$.

Moreover suppose to start in A and to want to reach B as in Figure 7. In order to do this we have to make one switching, let t_1 be the time of switching and let

$$u^1(t) = \begin{cases} u^{w=-1/2}(t), & \text{for } 0 \leq t \leq t_1, \\ u^{w=1/2}(t), & \text{for } t_1 \leq t \leq T, \end{cases}$$

be the control that steers the system from A to B with one switching.

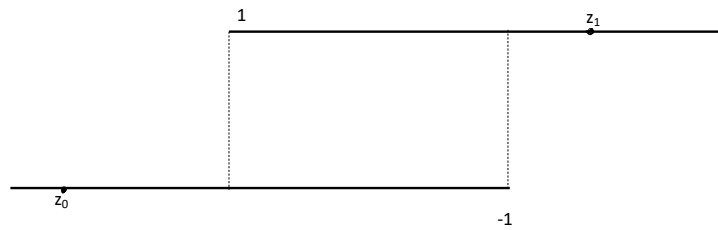

Figure 7. The relay hysteresis operator.

Consider now the same system where now w is given by half the sum of two relays operators (3.3), as shown in Figure 8,

$$\begin{cases} \dot{z} = g(w, z)u, \\ w = h_2[z, w^0]. \end{cases}$$

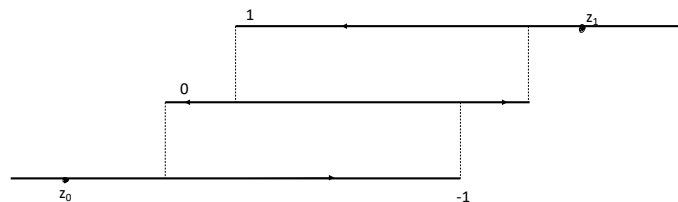

Figure 8. The sum of two relays hysteresis operator.

In order to pass from $(z, w) = (A, -1/2)$ to $(z, w) = (B, 1/2)$ we need to switch two times, let \tilde{t}_1, \tilde{t}_2 be the two switching times and let

$$u^2(t) = \begin{cases} u^{w=-1/2}(t), & \text{for } 0 \leq t \leq \tilde{t}_1, \\ u^{w=0}(t), & \text{for } \tilde{t}_1 \leq t \leq \tilde{t}_2, \\ u^{w=1/2}(t), & \text{for } \tilde{t}_2 \leq t \leq \tilde{T}. \end{cases}$$

Note that in the time intervals $[0, \tilde{t}_1]$ and $[\tilde{t}_2, T]$ the control $u^2(t)$ coincides with $u^1(t)$. In the middle time interval the vector field is $g(0, z)$ and the control $u^{w=0}$ is taken such that

$$g(0, z)u^{w=0} = g(-1/2, z)u^{w=-1/2}, \quad \text{for } \tilde{t}_1 \leq t \leq \tilde{t}_2. \quad (4.3)$$

In this way, the trajectories of (4.1)₁ and (4.1)₂ coincide up to time t_1 . From (4.3) we get

$$\|u^{w=0}\| \leq \frac{\|g(-1/2, z(\cdot))\| \cdot \|u^{w=-1/2}\|}{\|g(0, z(\cdot))\|},$$

where the norm $\|\cdot\|$ is the L^∞ norm in the compact $[\tilde{t}_1, t_1]$. Note that $g(-1/2, z(\cdot))$ is bounded in $[\tilde{t}_1, t_1]$ and that $g(0, z) \neq 0$ for all $z \in [\tilde{t}_1, t_1]$ because of the full generating assumption, which implies $\|g(0, z(\cdot))\| \geq c$ for some $c > 0$.

Analogously we have a similar inequality in the time interval $[t_1, \tilde{t}_2]$ using the control $u^{w=1/2}$ as reference i.e.,

$$\|u^{w=0}\| \leq \frac{\|g(1/2, z(\cdot))\| \cdot \|u^{w=1/2}\|}{\|g(0, z(\cdot))\|}.$$

In the case of k relays, similarly to (4.3), we can choose u^k such that

$$\begin{cases} g(w_k, z)u^k = g(-1/2, z)u^{w=-1/2}, & \text{for } 0 \leq t \leq t_1 \\ g(w_k, z)u^k = g(1/2, z)u^{w=1/2}, & \text{for } t_1 \leq t \leq T. \end{cases} \quad (4.4)$$

Hence the procedure above can be used when w is given by the sum of k relays bounding all controls with the norm of the controls with only one relays.

We now consider the general case where $g_i(w_i, \cdot) : \mathbb{R}^n \rightarrow \mathbb{R}^n$ for all $i = 1, \dots, m$. We exploit a similar idea to the one dimensional case. Let us start with one relays and one switching. To go from A to B we use a vector of controls (u_1^1, \dots, u_m^1) , which gives a trajectory z_1 . When we pass to the case of the sum of two relays we want to follow the same trajectory z_1 as before, that is $z_2 = z_1$. Let \bar{t}_1 be the possible first switching time for the output of one of the components of z_1 . In the time interval $[0, \bar{t}_1]$, we will use the same controls as with one switching, therefore we have that $z_1(\cdot) = z_2(\cdot)$. Let \bar{t}_2 be a possible second switching time, with output switching from w^1 to w^2 . In the time interval $[\bar{t}_1, \bar{t}_2]$ we want to use controls (u_1^2, \dots, u_m^2) such that

$$\dot{z}_1 = \sum_{i=1}^m g_i(w_i^1, z_1)u_i^1 = \sum_{i=1}^m g_i(w_i^2, z_1)u_i^2 = \dot{z}_2. \quad (4.5)$$

This is always possible if the $n \times m$ matrix G whose columns are the vector fields $g_i(w_i^2, z_1)$ has maximal rank $m \leq n$. Note that thanks to the condition (4.2), we can always assume that the vector

fields g_i of system (4.1) are linearly independent. Indeed, if they are not independent, there exists \bar{i} such that $g_{\bar{i}} = \sum_{j \neq \bar{i}} g_j$, but since condition (4.2) is satisfied, this means that the fields g_j with $j \neq \bar{i}$ alone generate the whole Lie algebra, thus system (4.1) can be rewritten, at least in a neighbourhood of the point z , with only $m - 1$ fields. Therefore we can find the controls u^2 as

$$\begin{pmatrix} u_1^2 \\ \vdots \\ u_m^2 \end{pmatrix} = G^+(w^2, z_1)(g_1(w^1, z_1) \cdots g_m(w^1, z_1)) \begin{pmatrix} u_1^1 \\ \vdots \\ u_m^1 \end{pmatrix},$$

where G^+ is the pseudoinverse of the matrix G (see [19, Chapter 19] for details). From this last relation it follows that

$$\|u^2\| \leq (\|G^+\| \cdot \|(g_1, \dots, g_m)\|) \|u^1\|, \quad (4.6)$$

where the norm of the pseudoinverse depends only on the norms of the vector fields g_j in a suitable compact set containing the trajectories. Indeed $\|G^+\|$ can be estimated by $1/\sigma$, where σ is the least singular value of G (see [19, Chapter 19]). Thus the controls used in the case of 2 relays have a norm which is bounded by a multiple of the norm of the controls used with only one relay. As in the one dimensional case, we can use this procedure at any step with k relays, and prove that the norm of the controls used with k relays are bounded by the norm of the controls used in the first step, which proves the equiboundedness with respect to k of the controls. \square

Remark 4.4. As stated in [19, Chapter 19], the pseudoinverse G^+ exists if the matrix G has maximal rank which, in our case, means that the columns are linearly independent as vectors of \mathbb{R}^n . We can certainly assume this fact. Indeed, due to the full generating assumption, for any point z and for all w , it is always possible to find a minimal number (possibly less than m) of linearly independent fields g_j in z , whose Lie algebra in z is still \mathbb{R}^n . We can choose these fields as columns of G , in particular in the right-hand side of (4.5). Finally note that norm inequality (4.6) still holds in any case, because of the boundedness of all fields g_j .

Proof of Theorem 4.2. For $A, B \in \mathbb{R}^n$, by Theorem 4.1 for every $k \in \mathbb{N} \setminus \{0\}$ there is a control $u^k = (u_1^k, \dots, u_m^k) \in L^\infty(0, T)^m$ such that the corresponding solution z_k of (4.1) _{k} satisfies $z_k(0) = A$ and $z_k(T) = B$. By standard estimates on the trajectories, by our hypotheses, z_k is bounded and Lipschitz on $[0, T]$. Moreover, by Lemma 4.3 the piecewise controls u^k are equi-bounded. This implies that the trajectories z_k are also equi-bounded and equi-Lipschitz in $[0, T]$. Hence, at least for a subsequence, as $k \rightarrow +\infty$,

$$u^k \rightarrow u \text{ weakly-star in } L^\infty(0, T)^m,$$

$$z_k \rightarrow z \text{ uniformly in } [0, T],$$

for some u, z , with z bounded and Lipschitz. By Theorem 3.1, by the fact that the trajectories z_k do not exit from a compact set of \mathbb{R}^n , by the regularity of the fields g_j , passing to the limit in the integral representation:

$$z_k(t) = A + \int_0^t \sum_{j=1}^m g_j(W_k[z_k \cdot \xi_j, w^0](s), z_k(s)) u_j^k(s) ds,$$

we get

$$z(t) = A + \int_0^t \sum_{j=1}^m g_j(\mathcal{TP}[z \cdot \xi_j, w^0](s), z(s)) u_j(s) ds.$$

Hence z is a solution of $(4.1)_{\mathcal{T}\mathcal{P}}$ such that $z(0) = A, z(T) = B$. This concludes the proof of the controllability of $(4.1)_{\mathcal{T}\mathcal{P}}$. \square

Remark 4.5. Usually the controllability of system without hysteresis (1.2) is guaranteed also using piecewise constant controls only. In the case of the controllability of $(4.1)_{\mathcal{T}\mathcal{P}}$ this fact seems to be not possible. Indeed when we are controlling the pair $(z \cdot \xi_j, w_j)$ moving constrained along the boundary of the stripe of the truncated play operator (see Figure 4), we need to change the control continuously, as we can see from the proof of Lemma 4.3 (see formula (4.4) for the construction of u_k). See also Remark 4.6.

Remark 4.6. Referring to Remark 4.5, let us note that in [8] the controllability of $(4.1)_k$ (see Theorem 4.1) is guaranteed with piece-wise constant controls (with, in general, exploding number of pieces as $k \rightarrow +\infty$). The controllability result for $(4.1)_{\mathcal{T}\mathcal{P}}$ as proven above by convergence of the problems for $(4.1)_k$ anyway shows that we can approximately steer $(4.1)_{\mathcal{T}\mathcal{P}}$ by piece-wise constant controls. Also note that in the proof of Lemma 4.3, instead of taking the first level $k = 1$ (one relay only) as reference, we can take any level with k large and hence possibly improve the rate of convergence of the controls and of the corresponding trajectories.

Remark 4.7. We notice that, in many applications, systems with a non zero drift term are also considered, that is (in the case without hysteresis) systems of the kind

$$\dot{z} = f(z) + \sum_{j=1}^m g_j(z)u_j.$$

The extension of the controllability results from the case without drift to the case with drift involves further non trivial conditions, even in the case without hysteresis. A first possible future approach to such extension in the case with hysteresis might consist in starting by considering a linear case exploiting a Kalman-type-condition.

5. On the possible extension to simple sweeping processes

Given a time-dependent law for the evolution of a closed nonempty convex set $t \mapsto C(t) \subseteq \mathbb{R}^n$, the sweeping process driven by $C(t)$ is given by the following differential inclusion in \mathbb{R}^n , for an initial status $w_0 \in C(0)$:

$$w' \in -N_{C(t)}(w(t)), \quad w(t) \in C(t), \quad t \in [0, T], \quad (5.1)$$

where $N_C(w)$ is the normal cone to the set C at the point $w \in C$. Under suitable assumptions on the regularity of the given evolution $t \mapsto C(t)$ (e.g., absolutely continuous in the Hausdorff distance), there is a unique absolutely continuous solution $t \mapsto w(t)$ of the problem (see Moreau [22]). If the evolution of the sets $t \mapsto C(t) \subseteq \mathbb{R}^n$ is interpreted as the input, then we can look to the evolution $t \mapsto w(t) \in \mathbb{R}^n$ as the corresponding output. Such an input/output relationship is a hysteresis relation (i.e., rate-independent, see for example Recupero [26], and Gudoshnikov et al. [13]) satisfying the semigroup property. In the following we specialize in some simple cases, just presenting some ideas and possible strategies for attacking the problem of the controllability with the sweeping process, leaving deeper studies to future investigations.

Let $C \subseteq \mathbb{R}^2$ be a rectangle with edges parallel to the axes x and y and, respectively, of semi-length $a > 0$ and $b > 0$. Let us denote by $t \mapsto c(t) = (c_1(t), c_2(t))$ the given continuous evolution of the center of the rectangular. We then have a “rigid and non-rotating” evolution of the rectangular

$$t \mapsto C(t) = [c_1(t) - a, c_1(t) + a] \times [c_2(t) - b, c_2(t) + b].$$

We consider the sweeping process in \mathbb{R}^2 driven by $C(t)$. In this particular case, by Krejčí et al. [18, Corollary 6.2] there exists a unique continuous function of bounded variation $w : [0, T] \rightarrow \mathbb{R}^2$ such that

$$w(t) \in C(t) \quad \forall t \in [0, T], \quad (5.2)$$

$$\int_0^T \langle w(t) - c(t) + v(t), dw(t) \rangle \leq 0 \quad \forall v \in C([0, T]; C), \quad (5.3)$$

$$w(0) = w^0 = (w_1^0, w_2^0) \in C(0), \quad (5.4)$$

where the integral in (5.3) is meant in the sense of Riemann-Stieltjes. Notice that (5.2)–(5.4) is an integral formulation of (5.1), due to the fact that w is not absolutely continuous.

Let \mathcal{P}_a and \mathcal{P}_b be the Play operators (non-truncated) with semi-amplitude a and b respectively. We have the following proposition.

Proposition 5.1. *The trajectory of (5.2)–(5.4) satisfies*

$$w(t) = (\mathcal{P}_a[c_1, w_1^0](t), \mathcal{P}_b[c_2, w_2^0](t)) \quad \forall t \geq 0. \quad (5.5)$$

Proof. If $w(t) = (w_1(t), w_2(t))$, then thanks to Krejčí [17, Corollary 2.3] we have that

$$\int_0^T (w_k(t) - c_k(t) + v_k(t)) dw_k(t) \leq 0, \quad k = 1, 2, \quad (5.6)$$

for all $v_1 \in C([0, T])$, $v_2 \in C([0, T])$ such that $v_1(t) \in [-a, a]$ and $v_2(t) \in [-b, b]$. Thus summing (5.6) with $k = 1$ and $k = 2$ we obtain (5.3) and we are done. \square

Let us note that (5.5) suggests that the solution operator of the problem (5.2)–(5.4) is a sort of vectorial play operator. Indeed in general the sweeping process driven by a moving convex set of the form $C(t) = c(t) - Z$, with $Z \subseteq \mathbb{R}^n$, is called “vectorial play operator” (see Krejčí [16]), and in the case of a set Z which is symmetric with respect to the origin, we can equivalently take $C(t) = c(t) + Z$.

A similar results as Proposition 5.1 holds in \mathbb{R}^n where $C(t)$ is the rigid non-rotating evolution of a hyper-parallelepiped with edges parallel to the axis and semi-length $a_i > 0$. If $t \mapsto c(t)$ is the evolution of the center, then

$$C(t) = [c_1(t) - a_1, c_1(t) + a_1] \times \dots \times [c_n(t) - a_n, c_n(t) + a_n].$$

We then have, for the corresponding sweeping process:

$$w(t) = (\mathcal{P}_{a_1}[c_1, w_1^0](t), \dots, \mathcal{P}_{a_n}[c_n, w_n^0](t)). \quad (5.7)$$

We then consider the controlled system in \mathbb{R}^n

$$\begin{cases} c' = \sum_{j=1}^m g_j(w, c)u_j, \\ w'(t) \in -N_{C(t)}(w(t)), \\ c(0) = c_0, w(0) = w^0 \in C(0), w(t) \in C(t) \forall t \geq 0, \end{cases} \quad (5.8)$$

where $g_j : \mathbb{R}^n \times \mathbb{R}^n \rightarrow \mathbb{R}^n$ are smooth and $C(t)$ is a hyper-parallelepiped.

As already mentioned in the introduction, here we propose the points of a work-plan for proving the controllability of system (5.8) with $C(t) = c(t) + Z$ both when Z is a hyper-parallelepiped and when it is a hyperball:

(1) We propose to deal with the case of Z hyper-parallelepiped by means of formula (5.7) by applying the controllability result Theorem 4.2 for the truncated Play operator.

(2) For the case Z hyperball we propose to split the problem into three steps.

a) *Approximation of the sweeping process with a ball Z , by sweeping processes with Z suitable intersections of a finite number of hypercubes.*

In the bi-dimensional case $n = 2$, we may think of the disc in the plane of radius r as the intersection of infinitely many squares of edge $2r$, with the same center and each one of them rotated by the angle $\theta \in [0, 2\pi]$ (see Figure 9). A point of the plane is inside the circle if and only if it is inside all those squares. Then the solution w of the sweeping process, with Z a ball, must lie inside all those squares at every t . Hence, something as the following is expected

$$w(t) \cdot (\cos \theta, \sin \theta) = \mathcal{P}_r[c(\cdot) \cdot (\cos \theta, \sin \theta), w_0 \cdot (\cos \theta, \sin \theta)](t)$$

for all $\theta \in [0, 2\pi]$ and all $t \geq 0$. Taking just a finite uniform discretization of $[0, 2\pi]$, $\{\theta^1, \dots, \theta^k\} \subseteq [0, 2\pi]$, one can consider the sweeping process w_k , with Z the intersection of the corresponding finite family of squares. Then, for such an approximating step, we should have

$$w_k(t) \cdot (\cos \theta^j, \sin \theta^j) = \mathcal{P}_r[c(\cdot) \cdot (\cos \theta^j, \sin \theta^j), w_0 \cdot (\cos \theta^j, \sin \theta^j)](t)$$

for all $j = 1, \dots, k$ and all $t \geq 0$. Similarly to what has been done in Section 3, our guess is that $w_k \rightarrow w$ as $k \rightarrow +\infty$, uniformly on the compact sets of time.

More generally, in \mathbb{R}^n , if Z is a hyperball of radius r centered at the origin, and $C(t) = c(t) - Z$, then we expect that

$$w(t) \cdot \varphi(\theta_1, \dots, \theta_{n-1}) = \mathcal{P}_r[c(\cdot) \cdot \varphi(\theta_1, \dots, \theta_{n-1}), w_0 \cdot \varphi(\theta_1, \dots, \theta_{n-1})](t), \quad (5.9)$$

where $\varphi(\theta_1, \dots, \theta_{n-1}) \in \mathbb{R}^n$ is the parametric description of Z , and similarly for the approximating step k .

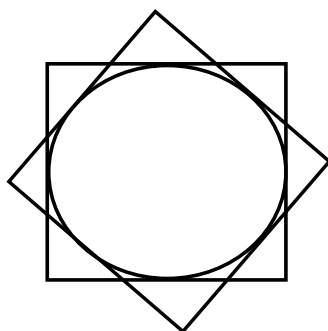

Figure 9. Circles and squares.

b) *Controllability of (5.8) when Z is the finite intersection of hypercubes.*

By point (1), we claim that one can get a positive result for such a problem.

c) *Passage to the limit.*

Arguing similarly as in Section 4 we claim that, using points a) and b) above, one can get a controllability result for (5.8) when Z is the hyperball.

We finally remark again that as a single scalar Play operator is approximated by finite weighted sums of delayed relays, similarly, here we intend to approximate sweeping processes driven by hyperballs by means of sweeping processes driven by hypercubes, which can be reduced to n scalar Play operators.

The study of the precise answers to the points above, as well as the generalization to Z a convex set, will be the subject of possible future research.

6. Conclusions

In this paper we give a controllability result for a driftless affine system with hysteretic nonlinearities of Play type. As a by-product we provide approximation results for the Play operators by means of finite sums of delayed relays. Finally, we outline a possible way to extend our results to the case of sweeping processes.

Use of Generative-AI tools declaration

The authors declare they have not used Artificial Intelligence (AI) tools in the creation of this article.

Acknowledgments

Bagaiolo and Recupero are partially supported by the GNAMPA-INdAM project 2025: Analisi e controllo di modelli evolutivi con fenomeni non locali. Zoppello is a member of INdAM group GNFM.

Conflict of interest

The authors declare no conflicts of interest.

References

1. L. Ambrosio, N. Fusco, D. Pallara, *Functions of bounded variation and free discontinuity problems*, Oxford university press, 2000.
2. A. A. Agrachev, Y. L. Sachkov, *Control theory from the geometric viewpoint*, Encyclopaedia of Mathematical Sciences, Vol. 87, Springer-Verlag, 2004. <https://doi.org/10.1007/978-3-662-06404-7>
3. F. Bagagiolo, Dynamic programming for some optimal control problems with hysteresis, *Nonlinear Differ. Equ. Appl.*, **9** (2002), 149–174. <https://doi.org/10.1007/s00030-002-8122-0>
4. F. Bagagiolo, On the controllability of the semilinear heat equation with hysteresis, *Phys. B*, **407** (2012), 1401–1403. <https://doi.org/10.1016/j.physb.2011.10.014>
5. F. Bagagiolo, K. Danieli, Infinite horizon optimal control problems with multiple thermostatic hybrid dynamics, *Nonlinear Anal.*, **6** (2012), 824–838. <https://doi.org/10.1016/j.nahs.2011.09.001>
6. F. Bagagiolo, R. Muggisto, M. Zoppello, Swimming by switching, *Meccanica*, **52** (2017), 3499–3511. <https://doi.org/10.1007/s11012-017-0620-6>
7. F. Bagagiolo, R. Muggisto, M. Zoppello, A hybrid differential game with switching thermostatic-type dynamics and costs, *Minimax Theory Appl.*, **5** (2020), 151–180.
8. F. Bagagiolo, M. Zoppello, Hysteresis and controllability of affine driftless systems: some case studies, *Math. Model. Nat. Phenom.*, **15** (2020), 55. <https://doi.org/10.1051/mmnp/2020023>
9. M. Brokate, J. Sprekels, *Hysteresis and phase transitions*, Applied Mathematical Sciences, Springer-Verlag, 1996. <https://doi.org/10.1007/978-1-4612-4048-8>
10. J. M. Coron, *Control and nonlinearity: mathematical surveys and monographs*, American Mathematical Society, 2007.
11. E. Feleqi, F. Rampazzo, Iterated Lie brackets for nonsmooth vector fields, *Nonlinear Differ. Equ. Appl.*, **24** (2017), 61. <https://doi.org/10.1007/s00030-017-0484-4>
12. C. Gavioli, P. Krejčí, Control and controllability of PDEs with hysteresis, *Appl. Math. Optim.*, **84** (2021), 829–847. <https://doi.org/10.1007/s00245-020-09663-6>
13. I. Gudoshnikov, O. Makarenkov, D. Rachinskii, Finite-time stability of polyhedral sweeping processes with application to elastoplastic systems, *SIAM J. Control Optim.*, **60** (2022), 1320–1346. <https://doi.org/10.1137/20M1388796>
14. M. A. Krasnosel'skii, A. V. Pokrovskii, *Systems with hysteresis*, Springer-Verlag, 1989.
15. M. I. Krastanov, M. Quincampoix, On the small-time controllability of discontinuous piece-wise linear systems, *Syst. Control Lett.*, **62** (2013), 218–223. <https://doi.org/10.1016/j.sysconle.2012.11.006>
16. P. Krejčí, *Hysteresis, convexity and dissipation in hyperbolic equations*, Gakuto International Series Mathematical Sciences and Applications, Vol. 8, Tokyo: Gakkotosho, 1997.
17. P. Krejčí, The Kurzweil integral and hysteresis, *J. Phys.: Conf. Ser.*, **55** (2006), 144–154. <https://doi.org/10.1088/1742-6596/55/1/014>

18. P. Krejčí, G. A. Monteiro, V. Recupero, Non-convex sweeping processes in the space of regulated functions, *Commun. Pure Appl. Anal.*, **21** (2022), 2999–3029. <https://doi.org/10.3934/cpaa.2022087>
19. J. Liesen, V. Mehrmann, *Linear algebra*, Springer, 2015. <https://doi.org/10.1007/978-3-319-24346-7>
20. I. D. Mayergoyz, *Mathematical models of hysteresis*, Springer-Verlag, 1991. <https://doi.org/10.1007/978-1-4612-3028-1>
21. A. Mielke, T. Roubíček, *Rate-independent systems: theory and application*, Springer, 2015. <https://doi.org/10.1007/978-1-4939-2706-7>
22. J. J. Moreau, Evolution problem associated with a moving convex set in a Hilbert space, *J. Differ. Equations*, **26** (1977), 347–374. [https://doi.org/10.1016/0022-0396\(77\)90085-7](https://doi.org/10.1016/0022-0396(77)90085-7)
23. T. Murphey, J. Burdick, A local controllability test for nonlinear multiple model systems, *Proceedings of the 2002 American Control Conference*, **6** (2002), 4657–4661. <https://doi.org/10.1109/ACC.2002.1025390>
24. F. Rampazzo, H. J. Sussmann, Commutators of flow maps of nonsmooth vector fields, *J. Differ. Equations*, **232** (2007), 134–175. <https://doi.org/10.1016/j.jde.2006.04.016>
25. V. Recupero, BV-extension of rate independent operators, *Math. Nachr.*, **282** (2009), 86–98. <https://doi.org/10.1002/mana.200610723>
26. V. Recupero, Sweeping processes and rate independence, *J. Convex Anal.*, **23** (2016), 921–946.
27. S. Tarbouriech, I. Queinnec, C. Prieur, Stability analysis and stabilization of systems with input backlash, *IEEE Trans. Autom. Control*, **59** (2014), 488–494. <https://doi.org/10.1109/TAC.2013.2273279>
28. A. Visintin, *Differential models of hysteresis*, Applied Mathematical Sciences, Vol. 111, Springer-Verlag, 1994. <https://doi.org/10.1007/978-3-662-11557-2>



AIMS Press

© 2025 the Author(s), licensee AIMS Press. This is an open access article distributed under the terms of the Creative Commons Attribution License (<https://creativecommons.org/licenses/by/4.0>)