

A scalable and flexible solution to evaluate the effects of the integration of photovoltaic distributed generation systems within the electrical grid

*Original*

A scalable and flexible solution to evaluate the effects of the integration of photovoltaic distributed generation systems within the electrical grid / Massano, M., Domingo, C.M., Macii, E., Patti, E., Bottaccioli, L.. - In: SUSTAINABLE ENERGY, GRIDS AND NETWORKS. - ISSN 2352-4677. - 43:(2025). [10.1016/j.segan.2025.101732]

*Availability:*

This version is available at: 11583/3000118 since: 2025-05-13T17:21:23Z

*Publisher:*

Elsevier

*Published*

DOI:10.1016/j.segan.2025.101732

*Terms of use:*

This article is made available under terms and conditions as specified in the corresponding bibliographic description in the repository

*Publisher copyright*

(Article begins on next page)



Contents lists available at ScienceDirect

## Sustainable Energy, Grids and Networks

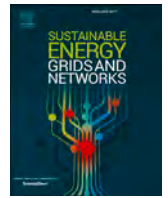
journal homepage: [www.elsevier.com/locate/segan](http://www.elsevier.com/locate/segan)

## A scalable and flexible solution to evaluate the effects of the integration of photovoltaic distributed generation systems within the electrical grid

Marco Massano<sup>a,\*</sup>, Carlos Mateo Domingo<sup>b</sup> , Enrico Macii<sup>a</sup>, Edoardo Patti<sup>c</sup>, Lorenzo Bottaccioli<sup>a,\*</sup> 

<sup>a</sup> Interuniversity Department of Regional and Urban Studies and Planning, Politecnico di Torino, Viale Mattioli, 39, Torino, 10125, Italy

<sup>b</sup> Institute for Research in Technology (IIT), School of Engineering (ICAI), Comillas Pontifical University, C. de Alberto Aguilera, 23, Madrid, 28015, Spain

<sup>c</sup> Department of Control and Computer Engineering, Politecnico di Torino, Corso Duca degli Abruzzi, 24, Torino, 10129, Italy

### HIGHLIGHTS

- The proposed methodology can generate synthetic electricity networks even when real-world data is limited.
- The high spatio-temporal granularity of the data structure enables detailed analyses of the impact of distributed PV systems on the distribution grid.
- Reasoning at the infrastructure level introduces a novel concept of spatial aggregation that promotes the creation of Energy Communities and local electricity self-consumption.
- The methodology can be used to identify and mitigate the challenges posed by distributed PV systems, such as reverse power flow, line congestion, and over-voltage problems.
- The proposed methodology can be used by a variety of stakeholders to evaluate different scenarios, test different aggregations, and design effective control strategies to ensure the stability and reliability of the distribution grid.

### ARTICLE INFO

#### Keywords:

Urban planning

PV integration

Synthetic electricity network

### ABSTRACT

This study introduces a novel methodological approach for evaluating the impacts of distributed photovoltaic (PV) generation systems within Urban Energy Systems (UES) on the distribution grid at an infrastructural level by generating synthetic electricity networks. The methodology integrates Geographic Information System (GIS)-based procedures, simulation techniques, and energy models to provide a comprehensive tool for analyzing electricity power flows at a high spatio-temporal resolution.

The study emphasizes the potential for localized energy sharing and the formation of Energy Communities. The adaptable platform supports operational and planning activities, offering detailed analyses for various urban settings. The methodology provides a valuable tool for identifying and mitigating the challenges posed by distributed PV systems, such as reverse power flow, line congestion, and over-voltage problems.

A case study focusing on the city of Turin was conducted, wherein a synthetic network of a specific urban area was created and analyzed. This detailed examination revealed critical network vulnerabilities triggered by the simulated integration of photovoltaic (PV) power, highlighting specific points that require attention to be effectively addressed. Furthermore, the study explores potential interventions to enhance the network's resilience and efficiency in accommodating distributed renewable energy sources.

The proposed methodology can be used by Energy Communities, Distribution System Operators, and other stakeholders to evaluate different scenarios, test different aggregations, and design effective control strategies to ensure the stability and reliability of the distribution grid.

\* Corresponding authors.

Email addresses: [marco.massano@polito.it](mailto:marco.massano@polito.it) (M. Massano), [lorenzo.bottaccioli@polito.it](mailto:lorenzo.bottaccioli@polito.it) (L. Bottaccioli).

## 1. Introduction

The reduction of greenhouse gas emissions is a critical challenge facing society today. To address this issue, the development of Renewable Energy Sources (RES) technologies is essential. However, green energy sources are discontinuous by nature, and current technologies suffer from suboptimal energy conversion efficiency. Consequently, a shift from a consolidated, centralized energy production model towards a more flexible and decentralized one has transpired. Advancements in Distributed Generation (DG) and smart grid management have opened the way for innovative energy management models. The integration of DG resources alters the balance of the current electricity distribution network by changing the timing and location of energy generation, as well as the methodology by allowing for the injection of electricity into the grid rather than solely extracting it. The increasing penetration of photovoltaic (PV) systems can lead to several technical challenges for the distribution grid, including:

- **Overvoltage:** Excessive injection of PV power during peak generation hours leads to voltage levels exceeding regulatory limits, potentially damaging grid infrastructure and connected devices.
- **Reverse power flow:** The bidirectional nature of PV energy, particularly in distribution networks not initially designed for such flows, causes operational instability and complicates grid management.
- **Line congestion:** Localized surges in power injection exceed the capacity of distribution lines, resulting in overheating and accelerated equipment wear.
- **Transformer overloading:** The capacity of transformers can also be exceeded during peak PV generation periods, creating thermal problems that accelerate aging and reduce the operational lifespan of these critical assets.

Addressing these challenges is critical for ensuring grid stability and operational efficiency. This study proposes a comprehensive methodology that combines synthetic grid modelling with high spatio-temporal resolution simulations. This approach enables stakeholders to identify critical bottlenecks, design effective mitigation strategies, and support the seamless integration of PV systems into the power grid.

To fulfil the European Union's (EU) commitments under the Paris Agreement [1], the European Commission introduced the "Clean Energy for All Europeans Package" (CEP) in October 2019 [2]. This reform promotes the adoption of innovative technologies and the active participation of consumers in the energy transition. This decentralization trend empowers consumers, encouraging them to generate their own electricity and reduce their reliance on the grid. Renewable energy self-consumption methods enable new collective actors and aggregators to operate in synergy according to *community* logic based on the exchange of bidirectional energy flows.

In addition to individual households' self-consumption of locally produced electricity, more advanced concepts, such as Energy Communities, have been developed [3]. Energy Communities are groups of individuals, organizations, or institutions that collaborate to produce, consume, and manage energy in a local area to benefit the economic, social, and environmental aspects of the region. They include private citizens, commercial activities, local public entities, or small and medium-sized enterprises that share the energy consumption produced by one or more renewable energy plants. Their participation, which is open and voluntary, is aimed at self-consumption, which is not directed towards profit, but towards the economic, social, and environmental benefit of the area in which they operate. Energy Communities empower *prosumers* to become active participants in the energy transition, leading to an empowered consumer and end-user centrality in the electricity market.

Regarding the regulatory framework, at the European level, the Recast Renewable Energy Directive (RED II) [4], defines the general goals for the energy transition and enables the legal establishment of

Energy Communities. However, the directive can be locally transposed with different specifics and standards, changing for different member states, and their detailed analysis is beyond the scope of this research. Two important concepts related to Energy Communities are worth highlighting. The first is that all participants of the Energy Community must be connected to the same medium-voltage substation. This concept promotes local electricity consumption, reduces the strain on the transmission grid and prevents complications that may arise from an excess of electricity being injected at the primary substation. The second concept is the introduction of a virtual regulatory model. In this setup, the excess self-produced electricity is simply injected into the distribution grid and becomes available for any other user connected to the grid. This approach incentivizes electricity consumption during the same time that it is being produced, encouraging users to synchronize their energy usage with the moments of peak generation, thereby enhancing the overall efficiency of the local energy ecosystem.

Geographic Information Systems (GIS) play a crucial role in the development of simulation and modelling tools for distributed energy systems. According to the Environmental Systems Research Institute (ESRI), GIS is "an organized collection of computer hardware, software, geographic data, and personnel designed to efficiently capture, store, update, manipulate, analyze and display all forms of geographically referenced information" [5]. GIS provides the geographical basis for simulating and modelling the smart energy systems [6]. GIS provides heterogeneous information for describing the environment of the area of interest, such as information on population distribution, buildings' presence and characteristics, localization of sensors (such as weather data) and Digital Elevation Models for reconstructing the area's morphology. GIS allows for accurate simulations in the territory for planning and evaluating power production from renewable and distributed energy sources. GIS enables the building of thematic maps, which are crucial in presenting and visualizing results for planners and decision-makers. Moreover, it is essential to work with open geospatial data, which can be freely downloaded, visualized and shared.

The primary aim of our tool is to support the initial stages of grid planning for renewable energy integration, focusing specifically on photovoltaic distributed generation (PV DG). Our tool facilitates detailed simulations and analyses to identify potential voltage and thermal limit violations that may arise from PV DG integration, providing valuable insights into the nature and location of these problems. This pre-analysis is crucial for stakeholders to understand the specific technical challenges before moving on to detailed planning phase. The paradigm shift towards a new way of conceiving energy requires the design of specific tools to support the energy transition, comprehending the impact of DG on power grids, and enabling effective storage planning and management. As the adoption of Energy Communities expands, there is a pressing need for an instrument that can facilitate the development and analysis of novel energy scenarios for both end-users and energy managers involved in short- and long-term planning activities. Innovative analyses that explore the enhancement and spatial expansion of distribution grids are essential. Scenarios simulating the energy behavior of an Energy Community must encompass elements such as the integration of RES, grid reconfiguration, demand response mechanisms, and demand-side management. This study focuses on evaluating the grid-level impacts of widespread PV integration, emphasizing infrastructural challenges and opportunities. Unlike approaches centered on dimensioning or optimizing Energy Communities, our work isolates the effects of PV integration by excluding storage systems. This decision ensures that the specific impacts of PV penetration on grid dynamics, such as reverse power flow and over-voltage, are clearly identified without interference from variables introduced by storage technologies. In recent studies, such as the evaluation of modern photovoltaic systems in Vietnam, the challenges of integrating large-scale PV systems into distribution grids have been highlighted, demonstrating the importance of addressing these issues in both preinstallation and operational phases [7].

Building upon the previous work of our research group [8], this paper proposes an enhanced design of a GIS-based distributed infrastructure for simulating energy exchanges occurring within an Urban Energy System (UES). We focus on integrating methodologies to simulate the electricity grid network and the power flows within it, paying particular attention to critical areas that could lead to bottlenecks in the evolving energy system. The proposed methodology combines various technologies and heterogeneous information to model energy flows and simulate the impact of novel control strategies in cities and distribution networks. Central to our methodology is addressing the pronounced gap in detailed electrical grid data, primarily due to the reluctance of Distribution System Operators (DSOs) to disclose comprehensive infrastructural details. This absence of granular data significantly impedes the effective integration of renewable energy resources, necessitating the development of advanced simulators that can generate plausible, synthetic representations of urban electrical grids. The generation of synthetic models is necessary when real network data is not publicly available. These realistic models can be highly beneficial for various stages of distribution network planning. By identifying critical areas and simulating the impact of PV DG integration, our tool facilitates targeted planning efforts, enabling stakeholders to determine necessary network extensions and reinforcements. Our approach transcends traditional administrative boundary-based methods by advocating for an infrastructural level of analysis centered on entities such as primary substations, facilitating a more nuanced integration of distributed generation within the urban fabric. Among these, the creation of Energy Communities and local electricity self-consumption is particularly highlighted due to their growing importance in Europe [9].

To enhance the distribution grid's operation and efficiency and support increased PV DG system penetration, stakeholders can use insights from our tool. Upgrading grid infrastructure, such as lines and transformers, can manage increased loads and mitigate overvoltage. Advanced load management strategies, like demand response programs, can balance demand and supply by shifting energy usage to times of high PV generation. Integrating storage systems, such as batteries, can store excess energy during peak production and release it during low generation or high demand, stabilizing the grid by smoothing out supply and demand variations.

To ensure an accurate representation of the energy infrastructure in the selected area, a detailed map that considers the PV-production systems, the energy demand, and the electric network is required. The platform must combine novel and existing modelling and simulation tools in an innovative simulation environment, and correlate heterogeneous information, such as census surveys describing the population, GIS data-sets, and urban cartographies. GIS-integrated systems are essential for representing the simulation environment and providing fundamental data such as the Digital Surface Model (DSM) and cadastral maps.

This comprehensive approach heralds a new paradigm in urban energy planning, enriching the strategic integration of distributed generation and accommodating the dynamism of electrical grids. Our tool focuses strictly on the technical pre-planning aspects to ensure broad applicability and flexibility. While it does not address costs, financial benefits, or public perceptions directly, it serves as a preliminary instrument to support a co-design process involving stakeholders and communities, aiming to maximize PV DG system penetration and acceptance. This approach aligns with Esposito et al. [10], which emphasizes community involvement and adaptive methodologies for successful renewable energy project implementation. The proposed methodology can generate synthetic electricity networks even when real-world data is limited. The high spatio-temporal granularity of the data structure enables detailed analyses of the impact of distributed PV systems on the distribution grid. Reasoning at the infrastructure level introduces a novel concept of spatial aggregation that supports various applications, such as urban planning, utility companies, and academic research. Among these, the creation of Energy Communities and local electricity self-consumption is particularly highlighted due to their growing importance in Europe. Energy Communities are becoming a pivotal element in the transition towards sustainable energy systems, promoting local energy production and consumption, enhancing grid resilience, and fostering community engagement, as emphasised in [9].

The rest of this work is organized as follows. Section 2 reviews relevant state-of-the-art solutions for modelling and simulating UES. Section 3 introduces the proposed methodology and the design of the simulation infrastructure. Section 4 presents the case study and the experimental results obtained by applying the proposed methodology in a real-world city. Finally, Section 5 discusses concluding remarks and future applications.

## 2. Literature review, theory and research gaps

Various methodologies have been developed to integrate PV systems in urban environments, and they have been applied to different study areas with varying spatio-temporal resolutions. To address the challenges identified in Section 1, a comprehensive review of the literature was conducted to identify the key strengths and weaknesses of solutions in this field. For all the reviewed solutions, particular attention has been paid to the granularity of both spatial and temporal resolution, enhancing those methodologies that favour a higher level of discretization. During the revision process, special attention was paid to the nature of the tools and data sources used (proprietary or open) as well as the technical structure of the methodologies (with keywords such as modularity and flexibility). The results of the literature review are summarized in Table 1, which reports all the significant features highlighted in the review.

**Table 1**

Overview of literature methodologies for assessing the impact of PV integration on the power distribution network.

Publication	GIS-based	Open dataset	Synthetic population	Synthetic network	Sub-hourly load simulation	Sub-hourly DG simulation	Dynamic grid analysis	Advanced scenario evaluation	Replicability
Liao et al. [15]	X	X	X	X	X	X	X	X	X
Birchfield et al. [16]	X	✓	X	X	X	X	X	X	✓
Soltan and Zussman [17]	✓	✓	X	✓	X	X	X	X	✓
Pisano et al. [18]	✓	✓	X	✓	X	X	✓	✓	✓
Schweitzer et al. [19]	X	✓	X	✓	X	X	X	X	✓
DINGO [20]	✓	✓	X	✓	X	X	X	X	X
Domingo et al. [21]	✓	✓	X	✓	X	X	X	X	X
Salimon et al. [22]	X	✓	X	X	X	✓	X	✓	✓
Szczesniak et al. [23]	X	✓	X	X	X	✓	✓	✓	✓
Soliman et al. [24]	X	✓	X	X	X	✓	X	✓	✓
Camargo et al. [25]	✓	✓	X	X	✓	✓	✓	✓	✓
Maghami et al. [26]	X	✓	X	X	X	✓	✓	✓	✓
Proposed solution	✓	✓	✓	✓	✓	✓	✓	✓	✓

Considering the electricity grid infrastructure becomes a key challenge when analyzing the effects of PV systems integration. However, few and limited test-cases and real-world power grid datasets are publicly and freely available [11]. To properly understand the effects of PV integration, realistic systems must be designed to accurately replicate the functioning of power grids. The integration of DG significantly alters the operation of electricity networks by enabling a reversed direction of power flow, sending power to the transmission network. High penetration of these resources on a weak grid may lead to voltage surges at the end of the distribution line, necessitating a review of voltage regulation and grid protection. To establish a functional smart grid, it is crucial to predict how the energy grid behaves when certain parameters are altered, and simulation is essential for this purpose. An electricity grid simulator must simulate the power flows between the utility and the consumers to study a wide range of planning and operational scenarios, such as power generation and transmission expansion planning.

In the literature, several works have focused on creating realistic reference networks and validation methodologies. In the field of research on synthetic networks, benchmarking networks are widely used to evaluate and compare various optimization and control algorithms, as well as for reliability calculations. Two of the most frequently employed network models for this purpose are the IEEE PES test feeder [12] and the CIGRE test network [13], which have made significant contributions to the field. However, these benchmark networks are designed for general purposes and may not be suitable for accurately representing the specific characteristics of real networks. Recently the European Commission published the *Distribution System Operators Observatory 2020* [14], which provides a comprehensive overview of the European electricity distribution system. As part of this project, large-scale and feeder-type network models based on real technical data provided by Distribution System Operators (DSOs) have been proposed. Following this approach, Liao et al. [15] proposed data-driven topology estimation methods for medium- and low-voltage urban distribution grids. These methods utilize historical smart meter measurements and capture statistical dependencies among bus voltages using probabilistic graph models. However, for unknown existing networks or to assist planners in choosing suitable routes for new lines, synthetic network simulators are necessary. Birchfield et al. [16] present a novel metric-based validation process for assessing the realism of synthetic power grids. The methodology uses data from real-world power grids to train a model that generates synthetic power grids. The data includes information about the structure of the grid, the proportions of different types of generators and loads, and the parameters of key power system elements. The metrics capture the structure, proportions, and parameters of key power system elements. The process was applied to two new public test cases, and it was found to be effective in assessing the realism of synthetic power grids.

Soltan and Zussman [17] developed an algorithm that generates synthetic spatially embedded power grid networks. Their approach employs a machine learning technique to generate a set of nodes that exhibit characteristics similar to those observed in the reference network. The methodology learns the distribution of real-world power grids, which includes factors such as the topology of the network, the location of nodes, and the length of lines. The proposed solution requires a large dataset of real-world power grids to train and is not able to generate networks with certain features, such as specific topologies or line lengths. Pisano et al. [18] propose a methodology for generating synthetic distribution networks based on open data and georeferenced information. The methodology uses a linear regression algorithm to generate load profiles from historical data, for each primary substation in the region. They used spatial databases to assign geographical coordinates to distribution network nodes and modelled a synthetic network in terms of lines, conductors, loads and generators. The methodology does not consider the impact of DG. Schweitzer et al. [19] introduce an innovative approach to automatically generate synthetic power flow scenarios using mathematical programming. The proposed methodology is based on the concept of constructing power systems by assembling constituent

parts, such as topology, generation, load, and branches. To achieve this, the methodology initially extracts these components from actual power grid data-sets. Subsequently, it formulates a Mixed Integer Linear Programming (MILP) problem to determine permutations of the sampled data that satisfy the constraints of a typical Optimal Power Flow (OPF) problem. Emphasizing a sampling approach, the methodology exclusively generates cases that accurately represent the data on which it was trained.

Amme et al. developed DINGO [20], an open-source software that utilizes the location of electricity demand in predefined areas to synthesize different grid topologies. The methodology synthesizes medium-voltage (MV) grid topologies by using a graph-based algorithm that takes into account the location of demand centres, the available MV network infrastructure, and the desired grid density. Initially, only load is considered aiming at minimizing circuit length. Subsequently, renewable power plants and additional loads are connected to the grid resulting in the cost-optimized MV distribution network. However, its applicability is limited to Germany, where it was designed and calibrated. Domingo et al. [21] introduced a methodology to reproduce a realistic quasi-optimal reference network. They design the high-, medium-, and low-voltage (HV/MV/LV) networks, including HV/MV substations and MV/LV transformers to supply the loads within a designated service area. The methodology was specifically developed to replicate the network of a geographical area of approximately 2 km<sup>2</sup> throughout Europe. Notably, the approach incorporates technical information obtained through the DSO Observatory project [14], making it an attractive tool for the electricity sector.

Recent advancements in incorporating photovoltaic systems within a distributed generation for urban energy frameworks have been significantly highlighted through studies aimed at optimizing the placement and sizing of these systems to improve grid performance. This includes focusing on reducing power losses, operational costs, and enhancing voltage stability. For example, Salimon et al. [22] explore strategies for the integration of photovoltaic technology, while Szczesniak et al. [23] and Soliman et al. [24] investigate voltage control in grids with high solar power penetration and the placement challenges of solar units in radial distribution systems, respectively. Camargo et al. [25] examine the impacts of solar power integration on urban microgrids, emphasizing the resilience and reliability of energy supply. Maghami et al. [26] assess how solar systems can be adapted across various urban layouts. Their study sheds light on merging solar systems with smart grid technologies, underlining the role of advanced metering infrastructure in optimizing solar system performance. These studies collectively highlight the need for innovative solutions to tackle the challenges in urban energy planning and grid stability, guiding our approach to fill the existing research gaps and enhance the integration of solar technologies in urban settings.

This paper introduces a comprehensive methodology that effectively bridges the observed gaps in previous research on the integration of photovoltaic (PV) systems into the urban electricity grid. Building upon our previous work [8], this approach extends the existing framework by incorporating a synthetic network and conducting a detailed power flow analysis. The synthetic network generator addresses a critical limitation in current research: the lack of publicly available, high-resolution grid data, which is often proprietary to DSOs. By synthesizing realistic network topologies, the generator enables the evaluation of future grid configurations under high PV penetration scenarios. By assimilating high-resolution spatio-temporal data on both electricity generation and consumption, our methodology leverages additional input parameters sourced from DSOs across various European regions. It integrates publicly available data, such as population census records and Open Street Map datasets, to enhance adaptability across diverse urban settings. This innovative approach ensures the feasibility of planning decisions from both an electrical and a spatial perspective, bridging technical and geographical insights within a GIS environment. By simulating realistic infrastructure-level interactions, such as reverse power

flows and line congestion, the synthetic network facilitates advanced scenario evaluations that would otherwise be impossible with existing datasets or tools. This capability positions the methodology as a pivotal instrument in advancing sustainable energy planning and grid resilience.

Our development of a distributed infrastructure that synergizes GIS with modelling and simulation techniques significantly advances the potential assessment of PV systems. This methodology, as outlined in [21], facilitates the estimation of energy generation and consumption profiles with unparalleled spatio-temporal resolution (25 cm and 10 min, respectively), identifying prime areas for PV deployment while considering environmental constraints and the shadowing effects on building rooftops. This precision allows for an accurate evaluation of solar energy production, factoring in real-world weather conditions for solar radiation estimation. The work presented in this manuscript extends [8] by integrating methodologies to generate a realistic synthetic power grid network and to simulate the intricate energy flows within a designated area. This methodology supports drawing concrete recommendations to promote knowledge and comprehension of UES and the integration of RES in the context of future smart cities. Additionally, it enables further considerations on the design and maintenance of an Energy Community, including the quantitative analysis of decentralized storage systems scenarios and strengthening of the distribution network.

Building on the foundation established in [8], the proposed solution in this paper introduces several enhancements that significantly elevate the accuracy and applicability of our methodology in urban energy system planning and development. These improvements address critical gaps in prior methodologies, as highlighted in Table 1, by integrating both energy production and grid infrastructure considerations. The key features of our approach include:

- **GIS-based:** The methodology employs GIS-based synthetic grids to accurately model urban energy systems, capturing infrastructural details essential for assessing the impacts of PV integration, such as spatial configurations and rooftop suitability.
- **Open dataset:** The framework leverages publicly available datasets, such as census and cadastral data, ensuring accessibility and adaptability across diverse urban contexts.
- **Synthetic network:** The methodology generates realistic synthetic networks to overcome the lack of real-world grid data, enabling detailed simulations of urban energy systems.
- **Synthetic population:** The framework generates a realistic synthetic population by combining census data, time-use surveys, and energy usage statistics to simulate consumption behaviors at fine-grained spatial and temporal resolutions.
- **Sub-hourly loads simulation:** The methodology uses sub-hourly temporal granularity to accurately simulate electricity consumption patterns, reflecting daily and seasonal variations in demand at both residential and non-residential levels.
- **Sub-hourly DG simulation:** By integrating sub-hourly PV generation simulations, the methodology captures real-sky conditions and shadowing effects, providing precise generation profiles for individual rooftops and aggregated areas.
- **Dynamic grid analysis:** By incorporating sub-hourly simulations, the methodology captures the dynamic interactions between PV generation and consumption, enabling detailed assessments of power flows, overvoltage risks, line congestion, and reverse power flows.
- **Advanced scenario evaluation:** The methodology facilitates the simulation of a broad range of scenarios, including varying PV penetration levels and urban energy configurations, to provide stakeholders with actionable insights for effective planning.
- **Replicability:** The framework integrates heterogeneous datasets, such as census, cadastral, and meteorological data, allowing for tailored PV deployment strategies that address the specific constraints and opportunities of different regions.

These features collectively advance the state of the art by overcoming the limitations of prior studies, which often suffer from low temporal or spatial granularity, limited replicability, or inadequate integration of energy and grid considerations. The proposed methodology offers stakeholders robust, precise, and practical tools to address critical challenges in PV integration, paving the way for a sustainable energy future.

Although existing approaches contribute significantly to specific aspects of urban energy system modelling, their methodological scope remains inherently fragmented. Table 1 provides a synthesis of recent literature [15–26], highlighting that each existing study typically addresses only a subset of functionalities. For example, Camargo et al. [25] propose a GIS-based simulation platform that incorporates sub-hourly PV generation and load dynamics but omits synthetic network modelling and detailed population behavior representation. Conversely, Pisano et al. [18] extensively utilize geospatial data for synthetic distribution network generation but do not include dynamic scenario evaluations, and Soliman et al. [24] specifically target advanced scenario analyses without integrating GIS-based spatial data or temporal load-generation dynamics. This methodological specialization limits the feasibility of a comprehensive and fair quantitative comparison across different studies, as each defines performance metrics based on its specific focus and scope.

To overcome these limitations, our methodology integrates independently validated components into a unified, coherent framework. Specifically, we leverage PV generation modelling validated against measured irradiance data [27], residential load profiling based on realistic occupant behaviors and extensively validated against empirical consumption data [28], grid power-flow simulation methods known for computational efficiency and robustness [29], and synthetic network modelling based on geospatial data and automated street map generation [21]. Furthermore, the adoption of standardized and harmonized data sources, such as the Harmonised European Time Use Surveys (HETUS) [30], enhances realism, reproducibility, and transparency of the simulated scenarios across diverse contexts. By providing an openly available, replicable simulation framework that encompasses synthetic population generation, GIS-driven network modelling, sub-hourly dynamic simulations, and detailed scenario analyses, our approach addresses current methodological gaps and facilitates broader adoption by researchers and industry practitioners.

Despite these advancements, our methodology acknowledges existing limitations and areas for future research. Even with a realistic synthetic electrical network, challenges such as the anticipated increase in electrification of consumption, and the integration of electric vehicles, batteries, and heat pumps remain. These factors, crucial for the evolving landscape of urban energy systems, underscore the continuous need for innovative strategies to address the integration of advanced energy solutions in urban settings. Our work lays the groundwork for addressing these complex challenges, pushing the boundaries of current research, and paving the way for more resilient and sustainable urban energy infrastructures.

The proposed solution presented in this paper is a valuable tool for assessing the potential of PV systems and simulating their impact on the electricity grid. It can be used to inform decision-making regarding the deployment of PV systems and the development of smart grid technologies. Thus, with this work, we aim to address the gap in literature solutions by providing a tool for designing and developing both future Energy Communities and future Smart Grids, paving the way for an integrated, sustainable urban energy future.

### 3. Materials and methods

The proposed methodology extends and enhances the previous solution presented in [8]. The design of our methodology and the deployment of simulation tools such as PV-Sim [27] and Home-Sim [28] draw upon a foundation established by rigorously validated preceding research. This prior work has not only provided us with robust

simulation frameworks but also with comprehensive datasets that critically inform our current study. Our objective extends beyond merely generating new datasets; we aim to synthesize and interpret available data to shed light on the dynamic interplay between distributed photovoltaic systems and urban electrical grids. Given the notable challenge of accessing detailed operational data from Distribution System Operators (DSOs) – a hurdle that significantly impedes the granular analysis of urban energy systems – we have developed specialized simulators. These tools are designed not as abstract models but as practical instruments capable of replicating missing or inaccessible data, thereby offering a nuanced understanding of potential impacts, and facilitating informed decision-making. In navigating these data limitations, our research prioritizes the correlation and analysis of existing data through advanced simulation techniques. This approach allows us to explore the implications of integrating renewable energy resources within urban settings, highlighting the potential for optimized energy distribution and the formation of resilient urban energy systems.

The diagram illustrated in Fig. 1 outlines the main functional layers (horizontal structure) and panels (vertical structure) of the proposed methodology. The platform’s architecture comprises three main vertical panels representing the principal components of the platform: the *Production Panel*, the *Consumption Panel* and the *Grid Panel*. To ensure the comprehensiveness and self-consistency of this paper, the beginning of this Section provides a brief overview of the referenced platform. However, we avoid getting too granular with the details because we have already extensively discussed it [8]. Subsequently, the latter part of this Section focuses on the structure of the proposed extension, offering a detailed description of the *Grid Panel* architecture.

The platform includes common layers that span across all panels, describing the various steps involved in the entire process. Each panel start with the *Data-source Layer*, where the raw urban input data (e.g., DSM, Cadastral maps, Time Use, Census data) is imported. In the *Scenario Creation Layer*, the input data-sources are processed and filtered in order to generate a georeferenced data-set. In the *Simulation Layer* the spatial and temporal distribution of electricity demand and supply is simulated and validated. Finally, in the *Application Layer*, the end-user defines aggregation geometry, various technical specifications and the main output results to generate.

The *Production Panel* estimates the electricity generation potential of PV systems in the analyzed area. It extends the GIS-based procedures for PV potential assessment by integrating advanced simulation techniques that consider both shadowing effects and real-sky conditions for solar radiation estimation. The panel conduct a nuanced analysis of potential PV electricity generation on building rooftops, by utilizing three main data sources: *i)* Cadastral maps, which are vector images containing building information such as area and location, *ii)* Digital Surface Model (DSM), which is a raster image that represents terrain elevation, considering both the morphological shape and buildings, *iii)* Real weather data, in particular solar radiation and air temperature. The *Rooftop Suitable Area* module employs high-resolution DSM to identify areas with suitable inclinations and orientations and exclude non-viable areas like chimneys and dormers. Subsequently, the *PV-Generation Simulator* generates electricity production profiles, extending the methodology of PV-Sim [27]. It uses a combination of clear-sky and real-sky condition simulations, making significant advancements in the accuracy of potential energy generation estimates. The *Consumption Panel* models and simulates the electricity consumption in the analyzed area. We developed a sophisticated simulation of residential and non-residential building energy demands. We create a comprehensive picture of urban energy consumption, by using four main data sources: *i)* Time Use surveys, used to build a user-activity model that simulates activities and behaviors of household members, *ii)* Use of Energy surveys, providing statistical distribution of appliances usage by family size, *iii)* Load Profiles of real appliances, *iv)* Census Data, which offers an overview of the population composition at various sub-geographical levels. By integrating a Synthetic Population module, we enhance the realism of our consumption profiles, ensuring they reflect the varied activities and behaviors of urban inhabitants. This module generates synthetic populations for different urban discretizations, offering a granular view of consumption patterns that align closely with real-world conditions. The *Electricity Demand Simulator* generates electricity consumption profiles for different types of buildings. For residential buildings, the methodology follows the Home-Sim approach [28] but integrates the synthetic population generated in the *Scenario-Creation Layer*. For non-residential buildings, the reference annual electrical consumption is scaled using the square meters of each non-residential building. The incorporation

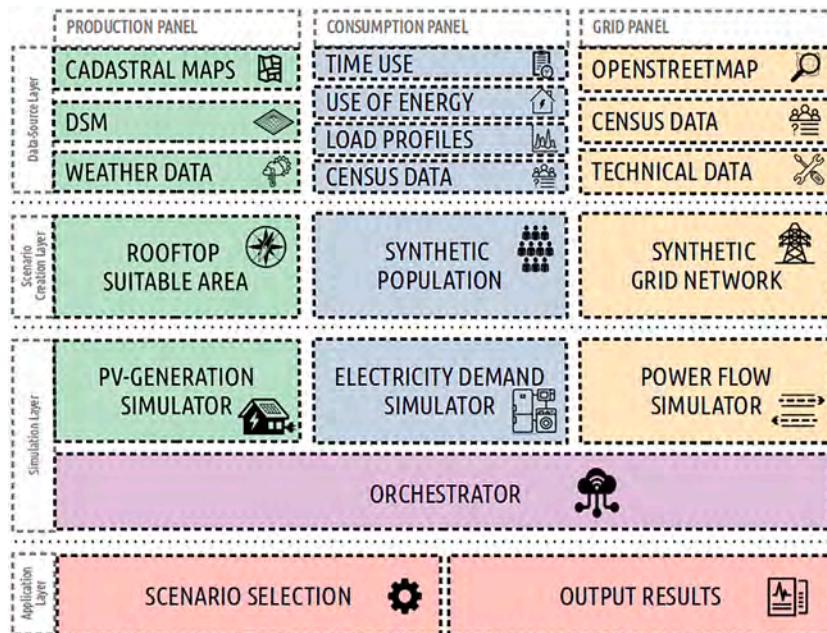

Fig. 1. Schema for the proposed platform.

**Table 2**  
Data collection insights, challenges, and mitigation strategies.

Data source	Collection time	Challenges	Mitigation strategy
GIS data	1 week	Gaps in coverage	Use OpenStreetMap or regional maps
Census data	2 weeks	Lack of granularity	Use national/regional averages
Weather data	1 week	Inconsistent formats	Standardize using public datasets
DSM	3 weeks	Restricted availability	Use synthetic models based on open-source tools and guidelines

of TUS data reflects daily and seasonal energy consumption patterns, while the use of real-time measured meteorological data dynamically adjusts for weather variations, ensuring comprehensive and realistic simulations. The *Grid Panel* evaluates the impact of PV integration on the electrical grid infrastructure. The panel reproduces the power grid infrastructure to analyze its robustness in accommodating the variable electricity generation from PV systems. The panel considers the grid topology, substation capacities, and transformer ratings, and assesses the grid's ability to handle the increased power fluctuations. The technical structure of this panel constitutes the innovation introduced in this paper, and will therefore be discussed in detail in this section.

The *Orchestrator* plays a crucial role in ensuring seamless integration and synchronization of the different simulation components within our methodology. It coordinates the operations of the *Production*, the *Consumption* and the *Grid Panels*, managing the flow of data and simulation results to produce a cohesive analysis of urban energy systems. By aggregating output results within a common GIS environment, the *Orchestrator* facilitates geospatial classification and analysis, enabling the examination of energy production and consumption at varying levels of geographical granularity. This level of coordination underscores the comprehensive nature of our approach, allowing for detailed urban energy planning and analysis. The *Scenario Selection* module provides flexibility by allowing users to specify various parameters, including the overall geographical area, spatial and temporal resolution, technical characteristics, and aggregation levels. The *Output Results* module generates instantaneous power values for PV power production, building power consumption, self-consumed power, and injected power. The platform also provides aggregated energy integrals at the end of the simulation. Two temporal indicators for PV integration are calculated: *i*) Self Consumption Ratio (SCR), which represents the share of PV electricity that can be effectively self-consumed, and *ii*) Self Sufficiency Ratio (SSR), which represents the share of electricity consumption that is fulfilled by the PV electricity.

The rest of this section describes the methodology designed to consider the electrical grid of the area of interest. The *Grid Panel* reproduces the power grid infrastructure used to distribute the electricity among buildings, substations and transformers, and analyses its robustness.

### 3.1. Data-source layer

The *Data-Source Layer* (the higher layer in Fig. 1) provides accurate information regarding the urban configuration of the area of interest. This layer gathers all the necessary data sources. Data from *OpenStreetMap* [31] (e.g., streets, buildings) are retrieved to construct the geographical structure of the area of interest. This information is required to understand the distribution network's path to optimally reproduce the actual distribution grid. *Census Data* typically provides statistics on families and populations. Within the present work, census data is used to locate synthetic families generated within the synthetic population module inside real buildings, allowing for the precise positioning of low-voltage users. *Technical Data* related to typical distribution grid specifics are also utilized. These data-sources are retrieved by the 2020 Joint Research Center Observatory [14], which collects technical information on the distribution grid system across Europe.

Our model relies on various data sources to construct a realistic simulation of energy consumption patterns. The primary data sources include

Census Data and TUS data. While obtaining complete Census datasets can be challenging, essential information can often be acquired through alternative means such as publicly available census summaries, municipal data sources, and open data portals. These national surveys are available in almost all countries and are largely comparable across countries [30]. This approach allows our methodology to remain robust and adaptable, even in data-scarce environments, ensuring comprehensive and accurate simulations.

The methodology further leverages publicly available geospatial data sources, such as *OpenStreetMap*, to enhance its adaptability and global applicability. In regions where DSM data may be inaccessible, the framework incorporates simplified, well-documented approximations to reconstruct synthetic network models. This approach ensures that the methodology remains feasible in both developed and developing contexts, addressing potential data limitations while maintaining analytical robustness.

To further illustrate the practicality of data collection and mitigation strategies for potential challenges, Table 2 summarizes the estimated time required for data acquisition, the main issues encountered, and the solutions adopted. This ensures the methodology remains robust and replicable across diverse contexts.

### 3.2. Scenario creation layer

The *Scenario Creation Layer* (the middle-low layer in Fig. 1) integrates and correlates the input data-sources provided by the *Data-Source Layer* to generate a georeferenced data-set for the *Simulation Layer*. The focus of this layer is to optimally replicate the environment where the infrastructure operates and provide the simulators with an accurate representation of reality.

The *Synthetic Grid Network* module generates a realistic quasi-optimal reference network to simulate the energy flows within the Energy Community. In this layer, there is an interaction with the Reference Network Model, described in [21], to create the synthetic grid, designed to evaluate the capabilities of the analyzed system. This model aims at planning the network while minimizing the investment, operation, maintenance and energy loss costs while respecting technical, geographical, and quality of supply constraints. It is structured into four layers, *a*) logical, *b*) topological, *c*) electrical, and *d*) quality of supply. Each of them complements the previous one with additional data, e.g., the logical layer models nodes and branches, the topological layer adds topological coordinates, the electrical layer includes electrical parameters of the equipment, and the quality of the supply layer adds information about faults and interruptions.

As shown in Fig. 2, the first step is the zonal classification that identifies settlements as part of the GIS module. This is done by detecting clusters of customers below a certain threshold (i.e., 350 m). Once the settlements have been identified, their outline is identified to differentiate urban and rural areas, as they have differential characteristics that lead us to consider topography and forbidden ways areas in rural areas, and street maps in urban areas. The case study of this paper is an urban area, and thus the model identifies all of the consumers as belonging to the same settlement. Then, the street map is generated. The procedure in [21] to construct the street map has evolved. The same algorithm is still used, but in addition to the consumers, points of the street map are also added (e.g., from *OpenStreetMap* [31]). This enables the street map to have more granularity and significantly more detail, the algorithm based

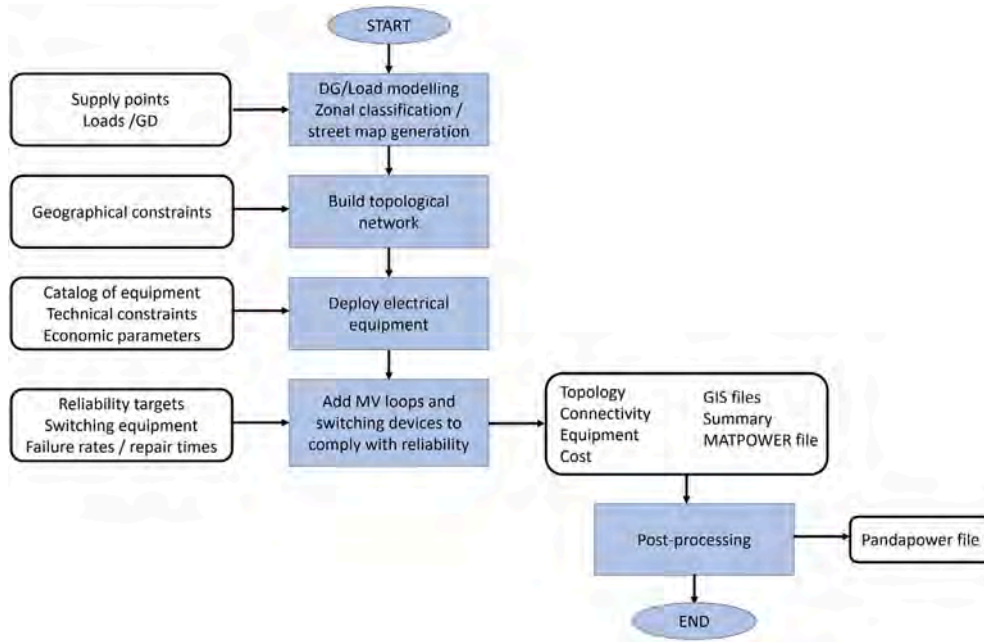

Fig. 2. Logical architecture of the Reference Network Model: steps involved and relevant input and output data.

on the Delaunay triangulation [21] still being very valuable to automatically identify branches connecting the street map points that can host power lines.

Once the geographical constraints have been modelled, the model proceeds bottom-up starting with the lower voltage levels, and then continuing with the upper voltage levels. Across all the voltage levels, there is an interaction between the GIS and the planning algorithms. In every layer, the planning algorithms optimize the network’s connectivity, and interact with the GIS (which models the geographical constraints) to obtain the potential locations for substations, and the best layout of power lines. At every voltage level, there are sources and loads. For example, in low voltage, the sources are the MV/LV transformers, and the loads are the low-voltage consumers. In medium voltage, the sources are the HV/MV substations and the loads are distribution transformers and MV consumers. In high voltage, sources are transmission substations and loads are HV/MV substations and HV consumers. For every voltage level, the sources are planned first; once all the sources and loads of the voltage levels are known, the topology is decided and the network is designed. For planning the sources (e.g., HV/MV substations, MV/LV transformers, etc.), clustering algorithms based on the minimum spanning tree are applied as described in [32]. Planning the network requires deciding the topology and the size of equipment. For the topology of power lines, the minimum spanning tree provides an initial solution, which is further improved using branch exchange. The aggregated demand and the discrete size of equipment are considered for sizing equipment. The algorithm identifies the optimal size of each power line, depending on the power flow through the power line, and considers the total cost of the power line, including its investment, maintenance, operation and energy loss costs. The last stage of the medium voltage network involves evaluating and improving reliability by installing switching devices and loops. In HV, the transmission substations are directly provided as an input, instead of being decided by the model.

The outputs of this module are the equipment and the layout of the high-, medium-, and low-voltage systems. For the network, this includes mainly HV/MV substations, MV power lines, switching devices, voltage control devices, MV/LV transformers, and LV power lines. There are additional files for consumers, street maps, etc. This information

is provided with detailed GIS files that contain the topology, the connectivity, and the main parameters of the equipment. In addition, a MATPOWER file is also outputted, enabling the computation of power flows. In this paper, we have also applied post-processing that feeds from the MATPOWER file and from complementary information like the layout of the network and its connectivity to convert the power flow model of the network into pandapower.

The methodology designs a synthetic network dimensioned by considering electricity demand values, reflecting the design principles of real-world power grids. The generated network is dimensioned to meet the electricity demand, by modelling the current scenario. Subsequently, within the *Simulation Layer* (see Section 3.3) the PV is introduced, and operational scenarios are defined to simulate prospective situations or assess PV potential.

### 3.3. Simulation layer

The *Simulation Layer* (the middle-up layer in Fig. 1) is responsible for providing the various simulation modules and defining a common structure that synchronizes and enables communication among the different software components.

The *Power Flow Simulator* is responsible for simulating the real power flows that occur within the analyzed area. The simulator takes as input the synthetic network generated in the *Synthetic Distribution Network* module and performs power flow calculations for all nodes of the grid network. The accuracy of our model in assessing the impact of photovoltaic distributed generation (PV DG) on the grid is supported by the pandapower framework [29], an open-source Python library that is well-documented for its robust and precise power flow analysis and state estimation. *Pandapower* combines the data analysis library *pandas* and the power flow solver *PYPOWER* to create a network calculation program for power system simulation. A key strength of *pandapower* lies in its ability to model and analyze large-scale power systems, encompassing both transmission and distribution networks. The *Power Flow Simulator* utilizes the Backward-Forward Sweep (BFS) method to perform power flow calculations, which is particularly well-suited for radial networks containing distributed generators [33,34]. In radial distribution grids, the reference voltage angle is dictated by the external grid, eliminating

the impact of relative voltage angle shifts of transformers on the power flow results.

This research focuses primarily on the following aspects:

- power transformer overloading, which occurs when the load exceeds the rated capacity of the transformer, can lead to potential overheating and equipment damage;
- line congestion, indicated by excessive current loading near the ampacity limit of the lines, can compromise the operation of the distribution system;
- overvoltage technical problems, where voltage levels deviate from the limits imposed by the EN50160 standard [35], can lead to equipment damage and safety concerns.

These elements serve as control parameters for the power flow analysis. As shown in Fig. 3 power flows are computed over a time-series, with a loop iterating through each time-step. For each time-step, a control loop is initiated, ensuring that the network converges while adhering to the defined boundaries and the controllers tuned by the end-user.

Power flows are computed at each node of the network, utilizing the values of power generation and consumption for each POD provided by *PV-Generation Simulator* and *Electricity Demand Simulator*. The main outputs of the simulator include:

- power profile and load utilization percentage at each transformer: this information is crucial for assessing the loading conditions of transformers and identifying potential overloading issues;
- power profile, magnitude, and phase angle of the voltage at each bus: monitoring voltage levels across the network is essential for ensuring compliance with technical standards and preventing overvoltage-related problems;

- active and reactive power flowing in each line: analyzing the power flow through each line provides insights into network congestion and potential bottlenecks.

The simulated power flows cover the entire year, enabling a comprehensive investigation of compliance with technical limits and constraints. While this simulation does not employ optimization algorithms due to the absence of economic analysis, it is important to note that *pandapower* can accommodate such analyses if required.

#### 4. Results and discussion

This section presents the main experimental results obtained through the application of the methodology described in Section 3 to the entire Municipality of Turin. This city was chosen as the case-study to test and validate the simulation of the proposed software infrastructure. Turin is a city located in Piedmont, northwest Italy, with approximately 130 km<sup>2</sup> of area and over 860,000 inhabitants [36]. The municipality is divided into 25 urban districts, 3775 census tracts, 58,461 buildings (including both residential and non-residential) and 9 main electricity transmission substations. The study considers the physical building as the fundamental unit of analysis, and the complete simulation procedure is implemented for each of the 58,461 buildings.

Three distinct scenarios were developed to highlight the diverse potential of the methodology. The selection of the following three case studies aims to demonstrate the platform's flexibility and reproducibility.

- Scenario A: *Residential Rooftops for Residential Consumption*. This scenario considers the electricity that can be generated from residential buildings to supply the electrical consumption of only residential buildings;
- Scenario B: *Total Rooftops for Residential Consumption*. This scenario considers the electricity that can be generated from all building types to supply the electrical consumption of only residential buildings.
- Scenario C: *Total Rooftops for Total Consumption*. This scenario considers the electricity that can be generated from all building types to supply both residential and non-residential consumption. The annual energy demand of all non-residential buildings is set to match the value of the tertiary classification in the Turin Energy Plan [37].

The analysis was conducted at both the District and Census Tract levels and revealed significant insights into the potential for PV system integration across different urban scales. Our findings indicated that, on a city-wide scale, the total estimated PV production capacity reached approximately 685 GWh/year, with residential buildings contributing around 353 GWh/year to this potential. Conversely, the total energy consumption within the city was estimated at approximately 592 GWh/year, emphasizing the substantial impact urban structure, and building density have on renewable energy generation capabilities. At the district level, our analysis provided a macroscopic view of potential PV integration, suggesting an overarching urban capacity for solar energy production. This broad analysis was pivotal in pinpointing districts with the highest potential for contributing to Turin's renewable energy goals. However, when the focus was narrowed to the Census Tract level, the analysis became significantly more detailed, uncovering intra-district variations that were not apparent in the district-level analysis. This finer resolution revealed specific areas within districts that were exceptionally suited for PV installation due to favourable rooftop orientations and minimal shading, among other factors. Such detailed insights were critical for identifying precise locations where PV systems could achieve optimal efficiency.

In the present study, we shift our focus towards an infrastructural-level examination. This approach delves deeper into the specifics of the urban electrical grid, analyzing how the integration of PV systems

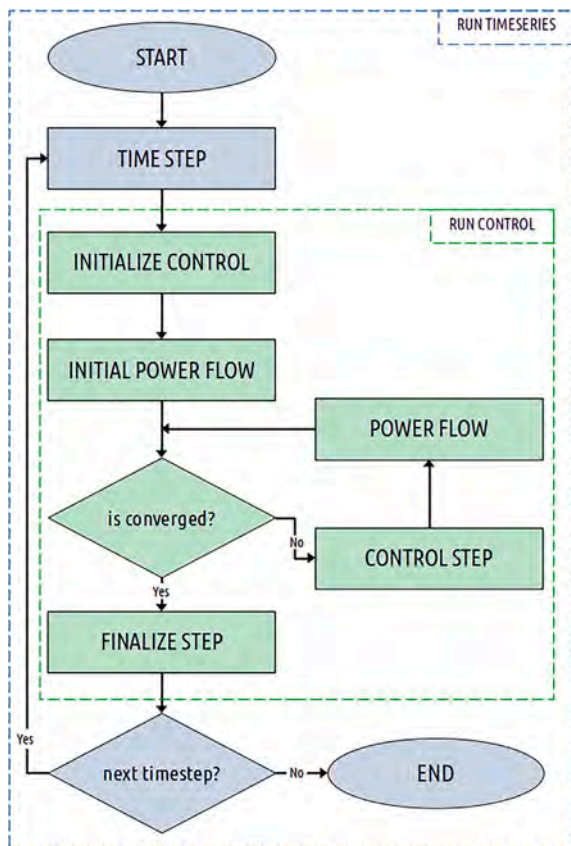

Fig. 3. Power flow time-series loop.

influences energy flows and grid stability within the intricate urban infrastructure. By building upon the generalized results of our previous work, this paper aims to provide a nuanced understanding of the operational challenges and opportunities presented by PV integration, emphasizing the critical role of detailed infrastructure analysis in enhancing urban energy resilience and sustainability.

Concerning energy transmission and distribution, the synthetic and realistic grid network generated as described in Section 3 connects the different entities within the defined aggregation geometry (e.g., physical building, census tract, city district). The main assumption is that any electricity generated by rooftop PV panels within the selected aggregation area can be instantly consumed by the buildings within that area, without considering energy losses or costs. With this assumption, self-consumed electricity can assume different meanings depending on the defined boundaries (e.g., condominium self-consumption, Energy Community self-consumption). Injected electricity, on the other hand, is the surplus energy that exceeds the instantaneous consumption needs of the area and represents the effective amount of generated electricity shared within the grid network.

The rest of this section discusses the experimental results at the infrastructure level. In this case, the aggregation geometry follows infrastructure-related boundaries rather than political ones, and the results are presented for all buildings connected to the same electrical substation. This section simulates the electricity grid network, enabling functional considerations on the integration of distributed PV systems into the actual electrical system. Fig. 4 shows the spatial distribution of the nine transmission substations located within the Municipality of Turin. Transmission substations act as supply points for the distribution networks.

The proposed methodology utilizes customer data (i.e., demand data) and transmission substation data to construct an optimal and realistic power distribution network that connects customers to the transmission system. Since detailed public data on the actual power grid's topology and topography are unavailable, the extent of each substation's influence is approximated. The synthetic distribution network interconnected with the transmission substation is generated using the methodology described in Section 3. However, the solution is flexible, and the synthetic grid can be easily replaced with the actual grid when it becomes available.

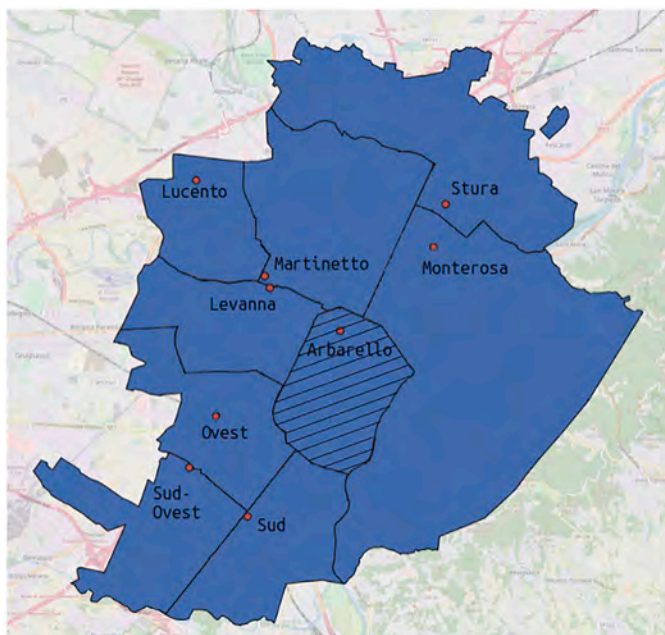

Fig. 4. Electricity substations for the Municipality of Turin.

Reasoning at the infrastructure level introduces a new concept of spatial aggregation that goes beyond traditional political boundaries. This approach offers a more robust and practical method for energy planning and integration. By simulating the area connected to each substation, it becomes possible to create Energy Communities. Concerning this aspect, it is important to highlight that the proposed solution is agnostic to regulatory frameworks. This means that changes in regulations do not affect the underlying structure of the platform. Instead, the platform itself can serve as a tool for evaluating and comparing the impacts of new rules.

The analysis presented in this section highlights the platform's capabilities in assessing the impacts of distributed PV generation on the operational performance of the electrical grid. This tool supports long-term decision-making in integrating PV generation into electrical grids, especially in light of forthcoming regulations that encourage the installation of PV arrays.

The foundation of our methodology, aimed at assessing the impact of distributed photovoltaic generation systems on the electrical grid, is based on the integration of validated approaches from our prior works [27,28]. These foundational studies have rigorously examined the performance of simulation algorithms using statistical indicators such as Mean Bias Deviation (MBD), Root Mean Square Deviation (RMSD), and the coefficient of determination ( $r^2$ ). Although this current study does not directly analyze these performance indicators, incorporating their methodologies ensures our research is based on empirically sound foundations and verified simulation principles.

Moreover, the integration of pandapower, an advanced power system simulation library, has significantly enhanced our computational efficiency. This efficiency is achieved through the integration of optimized algorithms for power flow and state estimation, which reduce the number of iterations needed for convergence and improve overall speed. These enhancements are well-supported by the performance benchmarks presented in the pandapower documentation [29]. Pandapower's ability to handle complex grid systems and perform detailed power flow analyses underpins our evaluations, providing a robust framework for our studies. This computational tool, combined with our empirical statistical assessments, forms the cornerstone of our approach, ensuring both reliability and efficiency in our simulations.

By incorporating these aspects into our methodology, we aim to provide a comprehensive and validated framework for analyzing the integration of photovoltaic systems into the electrical grid, offering valuable insights for stakeholders involved in the energy transition.

#### 4.1. Test case: Arbarello substation

To test and validate the proposed methodology, the simulation focuses on the portion of the grid network connected to the *Arbarello* substation (see the area with diagonal stripes in Fig. 4). This network is generated by considering the building's location from Cadastral Maps [38] and the street topology from OpenStreetMap [31]. Figs. 5 and 6 provide visual representations of the distribution of residential (dark blue) and non-residential (light blue) buildings within the defined area of the network infrastructure. This area is primarily composed of residential buildings (82%), with non-residential buildings (mostly commercial), accounting for the remaining 18%. The percentage distribution within the study area closely mirrors that of the municipality as a whole (78% residential, 22% non-residential), with the exception of a higher portion of industrial buildings in the rest of the city. All the buildings in the analyzed area are connected to the *Arbarello* transmission substation. Additionally, for each of the 4420 buildings, the effective suitable area for PV installation is indicated (depicted in black in the figures), which in our tests are fully deployed with PV systems.

Fig. 7 presents the synthetic electricity network interconnected with the *Arbarello* substation. Power systems can be best characterized as extensive interconnections of various subsystems that operate synchronously, encompassing generation stations, transmission substations,

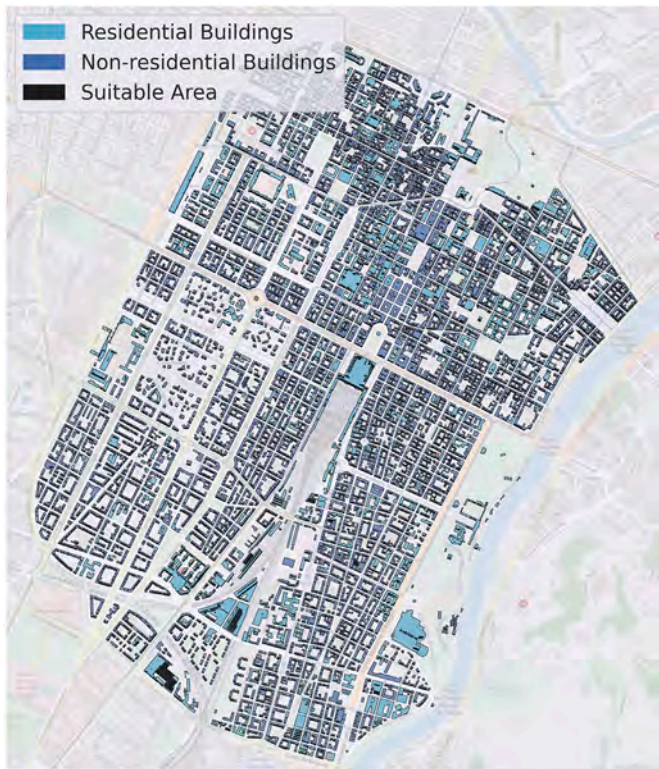

**Fig. 5.** Geographical distribution for the *Arbarello* substation: rooftops suitable areas for residential (light blue) and non-residential (dark blue) buildings. (For interpretation of the references to colour in this figure legend, the reader is referred to the web version of this article.)

and distribution systems. Their primary objective is to ensure a constant and reliable power supply, minimize energy losses, and maintain power quality indices within the EN50160 standards [35] while ensuring that distribution transformers and lines operate well within their rated capacity. In the simulated grid, each POD represents a building and is interconnected with other PODs and transformers through lines and cables. Each POD is associated with both rooftop PV production and

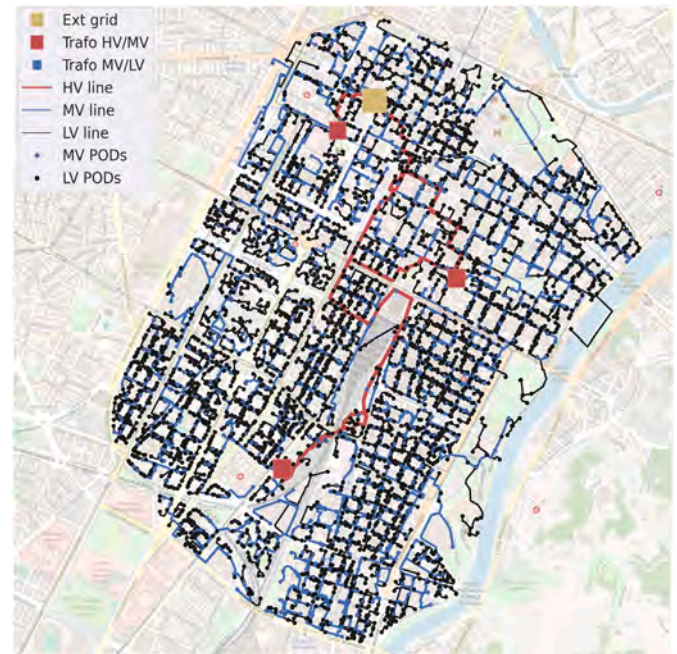

**Fig. 7.** *Arbarello* substation electrical network: external grid (yellow square), HV/MV transformers (red square), MV/LV transformers (blue square), HV lines (red line), MV lines (blue line), LV lines (black line), MV PODs (blue circle) and LV PODs (black circle). (For interpretation of the references to colour in this figure legend, the reader is referred to the web version of this article.)

electrical loads, which can include residential loads from households or non-residential loads from commercial buildings. Fig. 7 provides an overview of the high-voltage (HV), medium-voltage (MV), and low-voltage (LV) networks. This includes HV/MV and MV/LV substations, LV PODs primarily serving residential buildings, and MV PODs primarily serving non-residential buildings.

Fig. 8 provides a simplified electrical schema of the generated network, illustrating the overall structure and connections. To further understand the characteristics of the network, Tables 3 and 4 present key details regarding the transformers and lines involved. The electricity grid

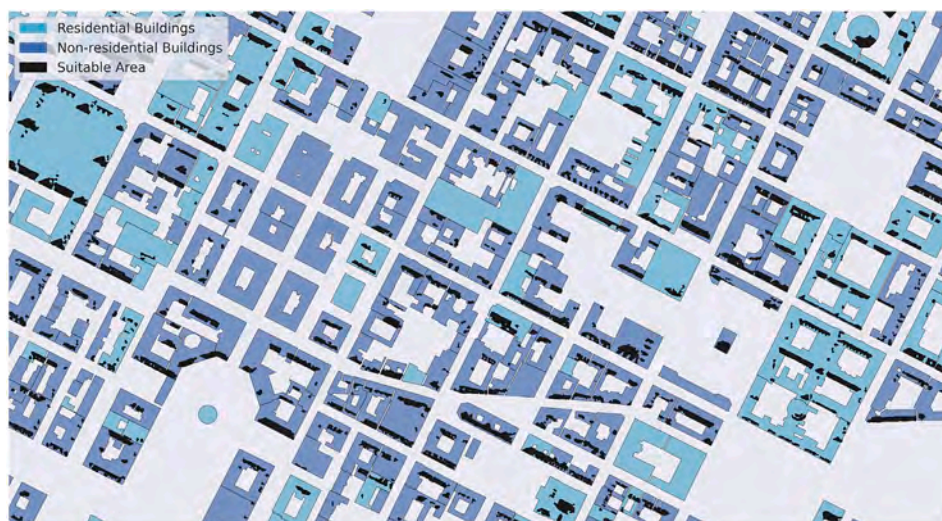

**Fig. 6.** A zoom of geographical distribution for the *Arbarello* substation: rooftops suitable areas for residential (light blue) and non-residential (dark blue) buildings. (For interpretation of the references to colour in this figure legend, the reader is referred to the web version of this article.)

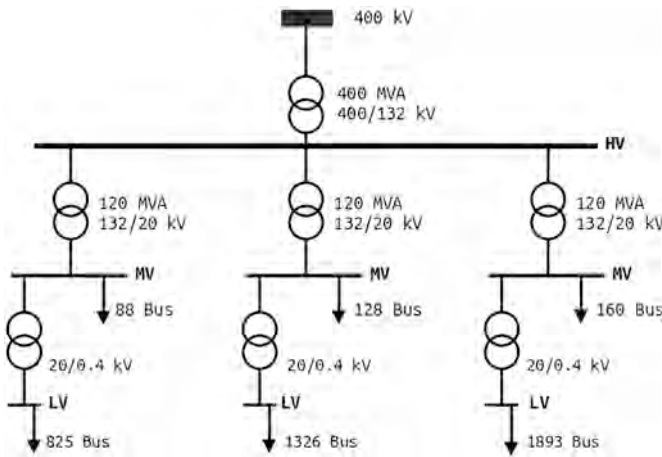

Fig. 8. Arbarello substation electrical schema.

Table 3

Key characteristics of network transformers, reporting: the number of transformers ( $n$ ), the rated voltage at high voltage bus ( $V_{n_{HV}}$ ) (kV), the rated voltage at low voltage bus ( $V_{n_{LV}}$ ) (kV), the rated power ( $S_n$ ) (MVA) and the short circuit voltage ( $v_k$ ) (%).

	$n$ [-]	$V_{n_{HV}}$ [kV]	$V_{n_{LV}}$ [kV]	$S_n$ [MVA]	$v_k$ [%]
Ext. Grid/HV	1	400	132	400	10
HV/MV	3	132	20	120	10
MV/LV	175	20	0.4	1	4.2
MV/LV	100	20	0.4	0.63	4.2
MV/LV	25	20	0.4	0.4	4.2
MV/LV	7	20	0.4	0.25	4.2

Table 4

Key characteristics of power lines and cables, reporting: the number of power lines ( $n$ ), the nominal voltage of the power line ( $V_n$ ) (kV), the mean resistance of the power line ( $R$ ) ( $\Omega$ /km), the mean inductance of the power line ( $X$ ) ( $\Omega$ /km), the total length of the power line ( $l$ ) (km) and the maximum loading capacity ( $i_{max}$ ) (kA).

	$n$ [-]	$V_n$ [kV]	$R$ [ $\Omega$ /km]	$X$ [ $\Omega$ /km]	$l$ [km]	$i_{max}$ [kA]
HV line	6	132	0.085	0.278	17.6	0.75
MV line	485	20	0.093	0.019	70.6	0.16
MV line	32	20	0.135	0.086	7.0	0.20
MV line	1	20	0.028	0.026	0.1	0.25
MV line	92	20	0.051	0.028	23.2	0.30
MV line	43	20	0.035	0.029	12.4	0.40
MV line	6	20	0.355	0.649	10.9	0.43
MV line	42	20	0.032	0.041	19.0	0.52
LV line	35	0.4	0.063	0.005	1.8	0.10
LV line	26	0.4	0.030	0.005	1.2	0.15
LV line	877	0.4	0.030	0.004	40.7	0.18
LV line	373	0.4	0.020	0.006	23.2	0.23
LV line	641	0.4	0.013	0.003	26.0	0.26
LV line	466	0.4	0.009	0.003	20.6	0.33
LV line	1626	0.4	0.006	0.003	80.5	0.42

comprises HV, MV and LV networks. The HV network receives power supply from the 400/132 kV transmission substation, which has a nameplate capacity of 400 MVA. This HV is responsible for supplying three primary substations via 18 km of HV cables. The MV network receives power from the three 132/20 kV primary substations, each with a nameplate capacity of 120 MVA. These primary substations then distribute power to 376 MV buses and 307 MV/LV secondary substations, through 143 km of MV cables and 26 main feeders, altogether. Finally, the LV network is supplied by 307 20/0.4 kV distribution transformers, with

capacities ranging from (0.25–1) MVA. These distribution transformers power 4044 LV buses, and their connection to the network is facilitated by 194 km of LV cables.

#### 4.2. Electricity generation and demand

The initial part of this result presentation focuses on the electricity generation and demand for the selected area. Table 5 summarizes the most important values and indicators, showing that the analyzed area extends over 157.5 km<sup>2</sup> and is populated by 105,297 individuals, living in 3634 residential buildings. The total electricity consumption of these buildings amounts to 89.0 GWh/year. When accounting for the 786 non-residential buildings, the overall electricity consumption rises to 290.5 GWh/year. It is observed that the PV electricity production alone is insufficient to meet the electricity demand in either scenario. However, in Scenario B, 83.9 GWh/year of electricity is generated from all buildings within the area. This production nearly covers the residential electricity consumption of 89.0 GWh/year. The electricity self-consumption in this area is slightly lower than the municipal average, accounting for approximately 20 % of the total electricity consumption and representing approximately 25 %–30 % of the total electricity production. As a result, both the SCR and SSR remain relatively low, never surpassing 46 % and 22 % respectively.

Following the examination of Table 5, we proceed with the analysis of results by briefly revisiting the definitions of the three main scenarios (A, B, and C) as outlined at the beginning of Section 4. This recap provides the necessary context to interpret the results presented in the subsequent sections.

- Scenario A: It considers the electricity that can be generated from residential buildings ( $E_{prod\_RES}$ ) to supply the electrical consumption of only residential buildings ( $E_{load\_RES}$ );
- Scenario B: It considers the electricity that can be generated from all building types ( $E_{prod\_TOT}$ ) to supply the electrical consumption of only residential buildings ( $E_{load\_RES}$ ).
- Scenario C: It considers the electricity that can be generated from all building types ( $E_{prod\_TOT}$ ) to supply both residential and non-residential consumption ( $E_{load\_TOT}$ ).

Fig. 9 illustrates the energy integrals for the entire year. Notably, the total electricity demand  $E_{load\_TOT}$  surpasses the generation capacity of a distributed rooftop PV system, even when considering all available buildings. However, a substantial portion of the total demand can still be met, which comes close to satisfying the electricity demand of the residential sector  $E_{load\_RES}$ .

Fig. 10 provides a comprehensive overview of energy flows throughout the year, offering valuable insights. The data confirm that the average monthly energy generation is not always sufficient to meet the energy requirements. Nevertheless, the data reveal that in certain months, the energy generation can satisfy the residential energy demand. This highlights the importance of considering detailed temporal aspects, as the annual integral values alone are not enough to fully understand the real energy dynamics. Specifically, in Scenario A the generated electricity could be sufficient to fulfil the residential loads only in July. In contrast, Scenario B demonstrates the ability to fulfil the demand from April to September. When considering the electricity consumption of the tertiary sector (Scenario C), it becomes evident that PV electricity production falls short of satisfying the electricity demand. However, during the summer months, PV production covers almost one-third of the total electricity consumption.

This issue becomes even more evident in Fig. 11, which shows the daily power flows of a typical day during winter (see Fig. 11(a)) and summer (see Fig. 11(b)). It is evident that PV production exceeds the electricity loads only during daylight hours when it is possible. Even on a summer day with longer daylight hours, the PV systems cannot directly supply the energy loads during the nighttime. To achieve

**Table 5**

Summary table for *Arbarelo* substation, reporting: area extension ( $S$ ) (km<sup>2</sup>), population ( $Pop.$ ), number of buildings ( $Build.$ ), suitable roof area ( $S_{avail}$ ) (km<sup>2</sup>), yearly consumed energy ( $E_{load}$ ) (GWh/year), yearly produced energy ( $E_{prod}$ ) (GWh/year), yearly self-consumed energy ( $E_{self}$ ) (GWh/year) and yearly injected energy ( $E_{inject}$ ) (GWh/year), self-consumption ratio ( $SCR$ ) (%) and self-sufficiency ratio ( $SSR$ ) (%).

SCENARIO	$S$ [km <sup>2</sup> ]	$Pop.$ [–]	$Build.$ [–]	$S_{avail}$ [km <sup>2</sup> ]	$E_{load}$ [GWh/year]	$E_{prod}$ [GWh/year]	$E_{self}$ [GWh/year]	$E_{inject}$ [GWh/year]	$SCR$ [%]	$SSR$ [%]
A	157.5	105,297	3634	29.8	89.0	57.8	20.0	37.8	33.5	19.7
B	157.5	105,297	4420	42.7	89.0	83.9	20.1	63.9	33.7	19.7
C	157.5	105,297	4420	42.7	290.5	83.9	40.7	43.3	46.1	22.0

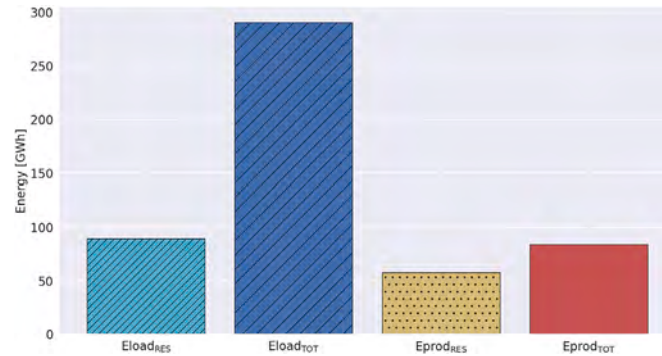

**Fig. 9.** *Arbarelo* Substation Annual Energy Integrals: yearly consumed electricity with residential buildings only ( $E_{load_{RES}}$ ) (GWh/year), yearly consumed electricity with all buildings (i.e., residential, commercial and industrial) ( $E_{load_{TOT}}$ ) (GWh/year), yearly produced electricity with residential buildings only ( $E_{prod_{RES}}$ ) (GWh/year), yearly produced electricity with all buildings (i.e., residential, commercial and industrial) ( $E_{prod_{TOT}}$ ) (GWh/year).

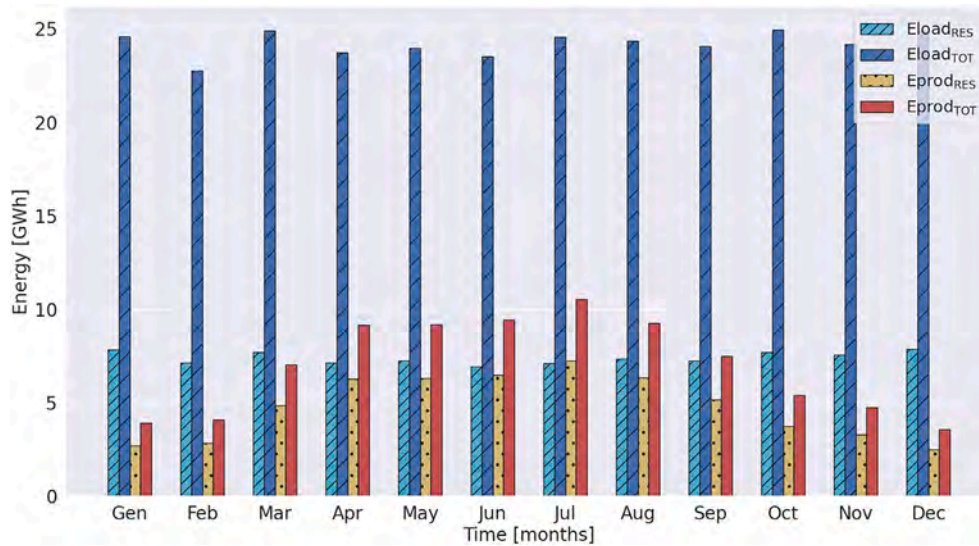
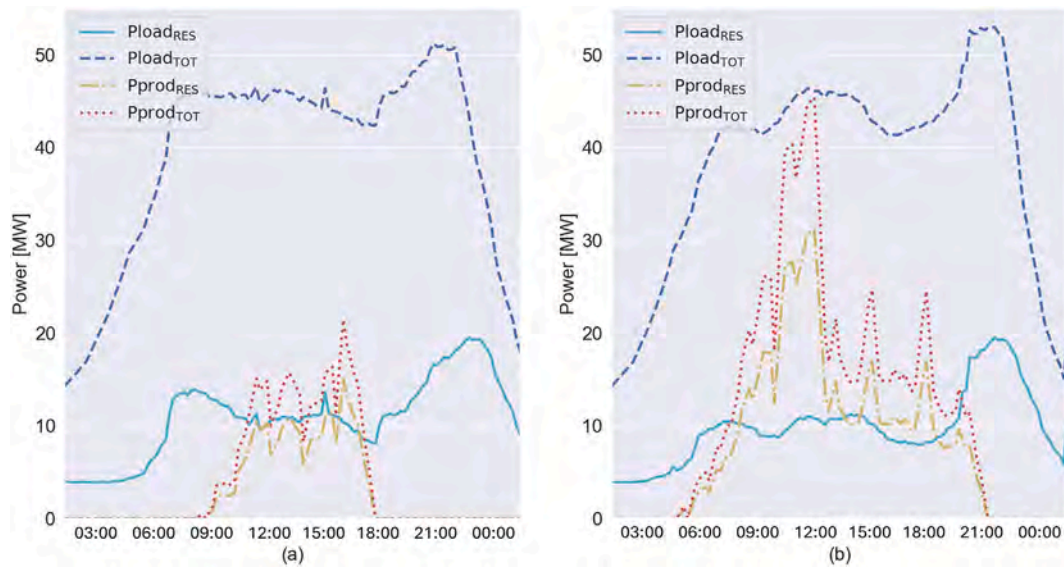

**Fig. 10.** Monthly energy integrals for *Arbarelo* substation: monthly consumed electricity with residential buildings only ( $E_{load_{RES}}$ ) (GWh/month), monthly consumed electricity with all buildings (i.e., residential, commercial and industrial) ( $E_{load_{TOT}}$ ) (GWh/month), monthly produced energy with residential buildings only ( $E_{prod_{RES}}$ ) (GWh/month) and monthly produced energy with all buildings (i.e., residential, commercial and industrial) ( $E_{prod_{TOT}}$ ) (GWh/month).

higher levels of self-sufficiency, further measures such as energy storage systems and demand-side management strategies may need to be implemented.

Scenarios A, B, and C define the framework of this analysis by differentiating the energy vectors involved in PV generation and consumption. Scenario A focuses solely on residential rooftops supplying residential consumption, while Scenario B expands the scope to include PV generation from all building types but still addresses only residential consumption. Scenario C, in contrast, incorporates PV generation from all building types and evaluates its contribution to meeting both residential and non-residential consumption.

The simulations for these scenarios span an entire year, capturing seasonal variations in PV generation and load profiles. These multi-scenario analyses provide a robust understanding of PV integration impacts across various temporal scales. Fig. 9 illustrates the annual energy integrals, highlighting the overall balance between generation and demand in different scenarios. Fig. 10 presents monthly energy flows, demonstrating seasonal variations and the degree to which PV generation meets residential and total consumption across different months. Fig. 11 provides a detailed view of daily power flows for typical winter and summer days, emphasizing the interplay between PV generation and consumption across seasons. The composition of energy vectors defining



**Fig. 11.** Daily power flows for Arbarello substation: daily consumed power with residential buildings only ( $P_{load\_RES}$ ) (MW), daily consumed power with all buildings (i.e., residential, commercial and industrial) ( $P_{load\_TOT}$ ) (MW), daily produced power with residential buildings only ( $P_{prod\_RES}$ ) (MW) and daily produced power with all buildings (i.e., residential, commercial and industrial) ( $P_{prod\_TOT}$ ) (MW).

the scenarios is embedded within these figures and can be interpreted by analyzing their details. This comprehensive approach ensures a detailed evaluation of PV system performance under varied conditions, offering actionable insights for future energy planning.

#### 4.3. The power flow analysis

This section presents a detailed analysis of the grid network based on power flow calculations for each node, taking into account the consumption and generation profiles generated by the proposed methodology. Only Scenario C, which considers the electricity consumption of both residential and the tertiary sectors, is considered. This choice is made because it would not be meaningful to simulate the network power flows considering only electrical loads from one category of buildings. Additionally, the grid network is tested with the maximum rate of PV production to assess the most stressful situation. The simulated power flow covers the entire year, enabling a thorough investigation of compliance with technical limits and constraints.

Although direct benchmarking with real-world grid data was not feasible due to data unavailability, the reliability of the results is supported by the use of extensively validated tools, such as pandapower and GIS-based modelling techniques. Pandapower, a well-documented open-source library, has demonstrated its robustness in numerous applications involving power flow simulations and state estimations for both transmission and distribution networks. Similarly, GIS-based frameworks are widely recognized for their accuracy in representing urban energy systems. Furthermore, the trends observed in this study, such as line congestion, reverse power flow, and overvoltage, are consistent with findings reported in studies such as [22,24,26]. This indirect benchmarking underscores the methodological soundness of the approach and provides further validation of the correctness of the results.

As explained in Section 3, the following aspects have received particular attention:

- power transformer overloading, which occurs when the load exceeds the rated capacity of the transformer;
- line congestion, indicated by excessive current loading near the ampacity limit of the lines;
- overvoltage technical problems, where voltage levels deviate from the limits imposed by the EN50160 standard [35].

To assess compliance with the technical constraints, a dedicated plot has been generated, offering a comprehensive analysis of the performance of various components in the grid network. This analysis involves the creation of reference daily profiles for each parameter, taking into account weekdays and weekends, as well as different seasons of the year. Each profile represents the maximum value for its respective class, allowing for a thorough evaluation of the system's performance. The detailed analysis enables a better understanding of the behavior and limitations of the grid network components under different operating conditions. By considering variations in consumption and generation patterns throughout the year, the analysis captures the most critical scenarios that the components may experience. This information is valuable in assessing the adequacy of the grid infrastructure and identifying potential areas that require attention or improvement.

##### 4.3.1. Power transformers

Fig. 12(a) and (b) illustrate the main technical results for the six different classes of transformers described in Table 3. Each plot presents the maximum profile of the analyzed parameter obtained from one transformer belonging to the respective transformer class. Fig. 12(a) displays the maximum daily electrical power profiles passing through the transformers, capturing the peak periods when the transformers experience the highest load. Fig. 12(b) illustrates the load utilization percentage relative to the rated power for all six transformer classes. This parameter indicates how effectively the transformers are being utilized, with respect to their rated capacity.

The results demonstrate that all transformers have complied with the rated power values specified in Table 3, with a maximum load utilization value of less than 70 %. This suggests that the transformers are operating within their specified limits and are capable of handling both the electrical power demand and the PV electrical power injection effectively.

##### 4.3.2. Electrical lines

Fig. 13(a) and (b) provide an overview of the main technical results for the 15 classes of lines described in Table 4. Fig. 13(a) illustrates the maximum daily current profiles flowing through the electrical cables, capturing the peak current values experienced by each line class. Fig. 13(b) showcases the line loading percentage relative to the rated

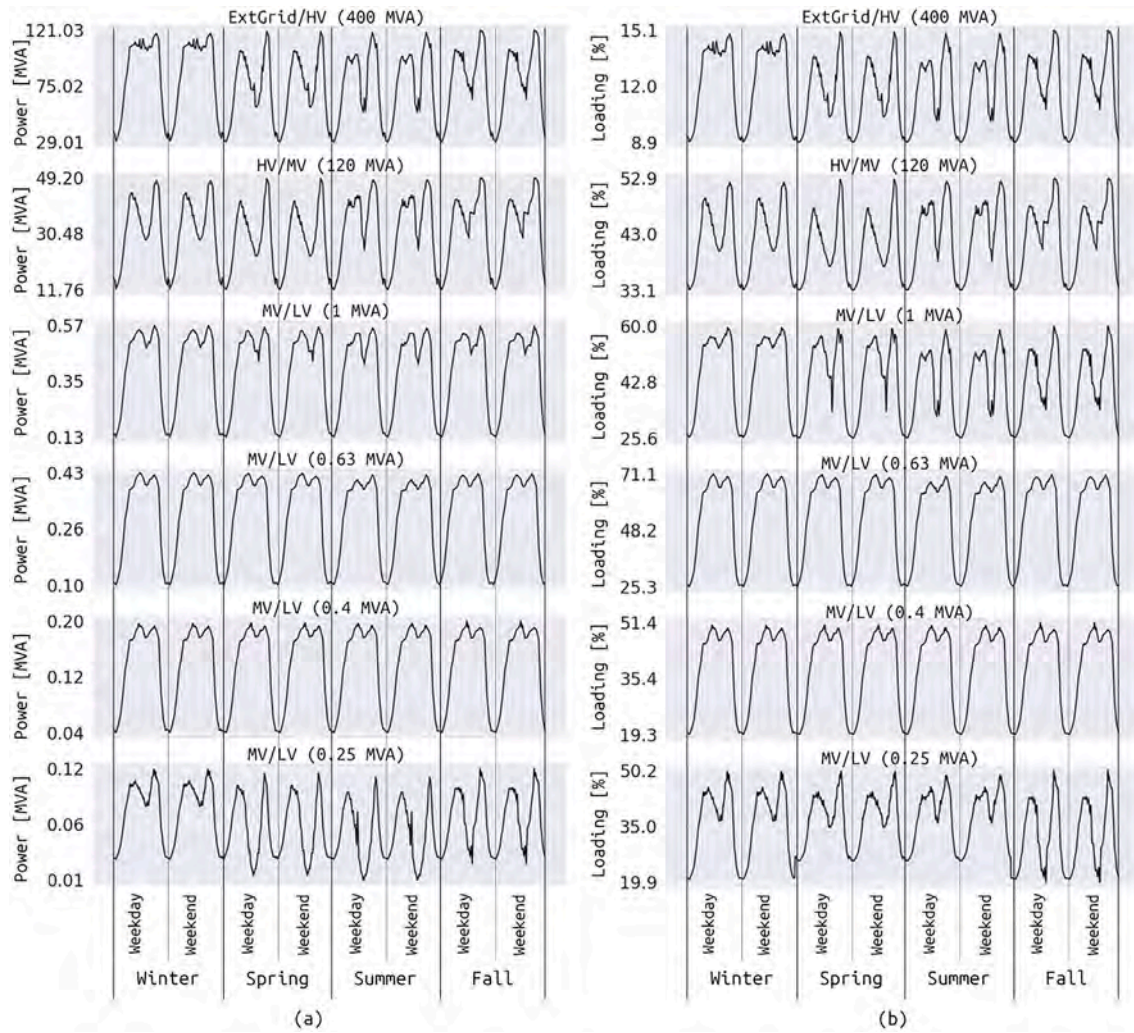

Fig. 12. Power flow results for six transformer classes: (a) maximum power daily profiles and (b) maximum load utilization daily profiles.

current for each type of line, indicating the extent to which the lines are utilized compared to their rated capacity.

It is important to note that not all line classes have met the rated current values specified in Table 4. Specifically, the line class with a rated current of 0.18 kA exceeded its capacity, reaching a maximum line current of about 0.37 kA (in red in Fig. 13(a)) and a maximum load utilization value of 213 % (in red in Fig. 13(b)). Similarly, the line class with a rated current of 0.26 kA exceeded its capacity, with a maximum line current of about 0.44 kA (in red in Fig. 13(a)) and a maximum load utilization value of 174 % (in red in Fig. 13(b)). These results indicate that the current flowing through these lines surpassed their intended capacity, which may lead to various issues such as performance degradation, overheating, or potential equipment failures.

Further investigation reveals that the violation originated from six LV lines, which experienced line congestion issues. Line congestion occurs when the current flow exceeds the rated capacity of the line, leading to adverse effects on the overall performance and reliability of the distribution grid. Identifying these problematic lines allows for targeted interventions and measures to alleviate congestion and ensure that the network operates within its technical limits.

#### 4.3.3. Buses

Fig. 14(a) and (b) present the main technical results for the two classes of buses in the network: LV and MV. Each bus represents a POD,

which corresponds to a building and is equipped with both consumption and production profiles. The analysis focuses on the net electricity passing through each bus, calculated as the instantaneous difference between electricity consumption and generation.

Fig. 14(a) illustrates that the net power can have negative values, indicating cases where electricity production exceeds consumption. This excess electricity is injected into the grid in the opposite direction, resulting in a negative sign. As shown in the lower graph of Fig. 14(a), reverse flow also occurs for MV buses, even though the higher consumed power generally surpasses the power that can be generated. These negative power values emphasize the importance of carefully controlling the network, particularly in older grids that may not have been designed to handle reverse power flow. Managing reverse power flow poses specific challenges that need to be addressed to ensure the real-time operation of the network.

Fig. 14(b) presents the voltage variation for the two bus classes. It is observed that for LV buses, the unitary voltage values reach up to 1.39 [p.u.], indicating overvoltage technical problems that exceed the limits of  $\pm 0.1$  p.u. specified by EN50160 [35]. Further analysis reveals that the 10 buses that exceeded the limits are primarily commercial buildings with no electrical consumption but only electricity generation from rooftops. As a result, there is no self-consumption, and all the PV electricity generated is injected into the grid, resulting in a dramatic increase in several bus voltages in sections of the distribution system that

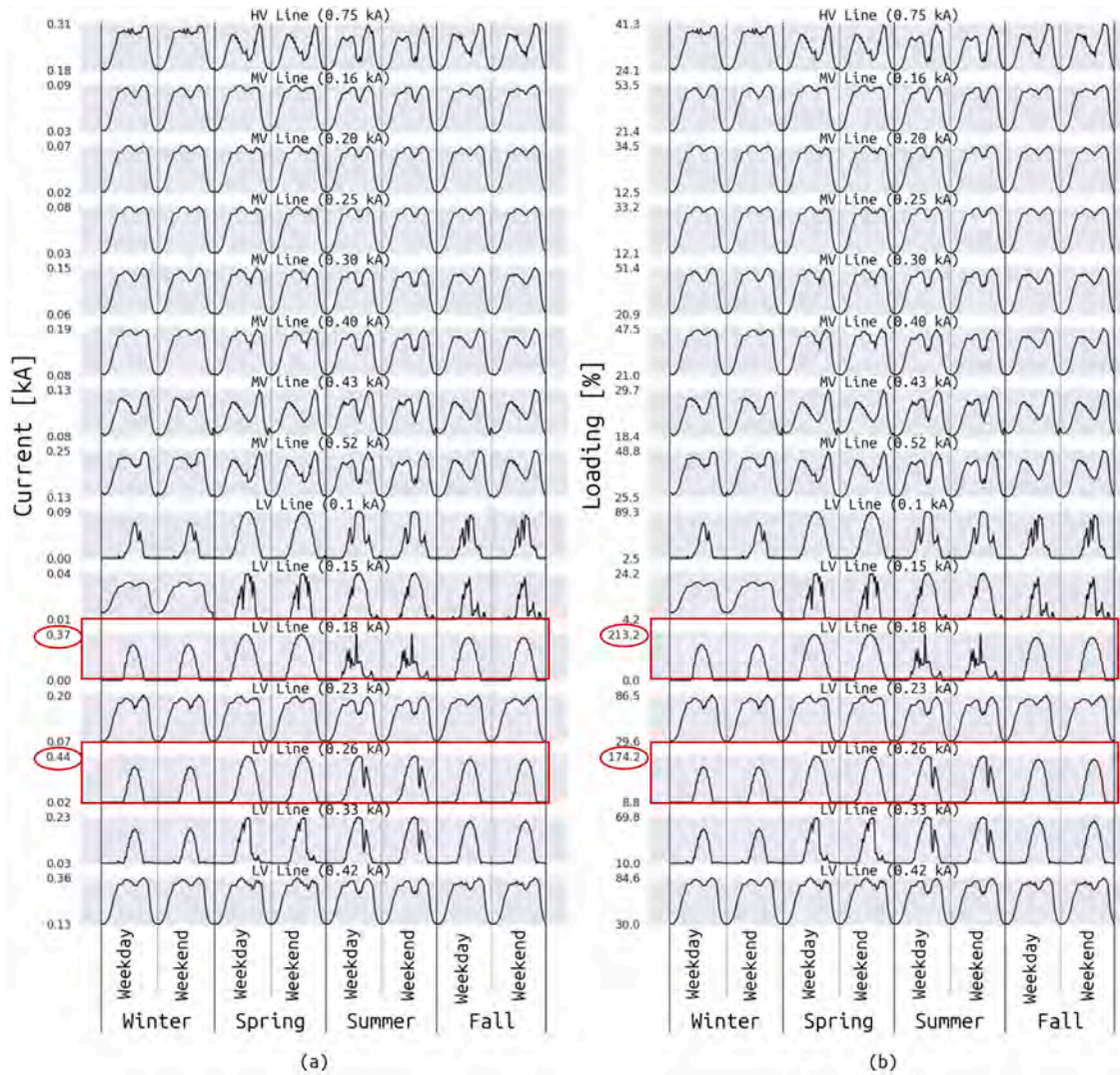

Fig. 13. Power flow results for three line classes: maximum line loading daily profiles.

were not designed to withstand these injections. Notably, these critical LV buses are connected to LV lines that suffer from line congestion, thereby exacerbating the problem.

This methodology presents a valuable tool for conducting further analysis aimed at addressing grid challenges, such as overvoltage and line congestion. Potential approaches to enhance the operation and efficiency of the distribution grid include infrastructure upgrades, load management strategies, and the implementation of electricity storage systems. By implementing these measures, the issues identified in the study can be effectively addressed, ensuring that the grid operates within the required technical limits. For instance, upgrading the line connecting the overvoltage buses could be a solution in this particular case. Indeed, the logic behind the generation of the synthetic network considers the retail nominal power of each bus, which consists of the electricity demand. Therefore, when designing a PV plant on building rooftops, careful consideration of the electrical connection and potential enhancements is necessary.

An interesting observation arises from the examination of the path covered by the reverse flow, which is absorbed within the LV lines, rather than reaching the MV/LV transformer. This suggests that excess electricity is locally utilized to meet the electricity demand of other

buses connected to the secondary substation. This localized energy sharing among neighbouring buildings, which are connected to the same transformer, presents opportunities for optimization and the formation of Energy Communities.

This section provides valuable insights into energy demand and supply patterns at the infrastructural level. It highlights the benefits of implementing distributed PV systems and emphasizes the importance of considering infrastructure-related boundaries to accurately represent energy usage patterns. By considering these factors and exploring the concept of Energy Communities, it becomes feasible to promote the integration of renewable energy sources and optimize the operation of the distribution grid.

The integration of PV into urban energy systems is a key driver of the transition to a sustainable energy future. However, the increasing penetration of PV systems can pose challenges to the distribution grid, such as overvoltage and line congestion. This study presents a methodology for evaluating the impact of distributed PV systems on the distribution grid at the infrastructural level. The results of the study highlight the importance of infrastructure-related boundaries and localized energy sharing in accurately representing energy usage patterns and designing effective grid integration strategies.

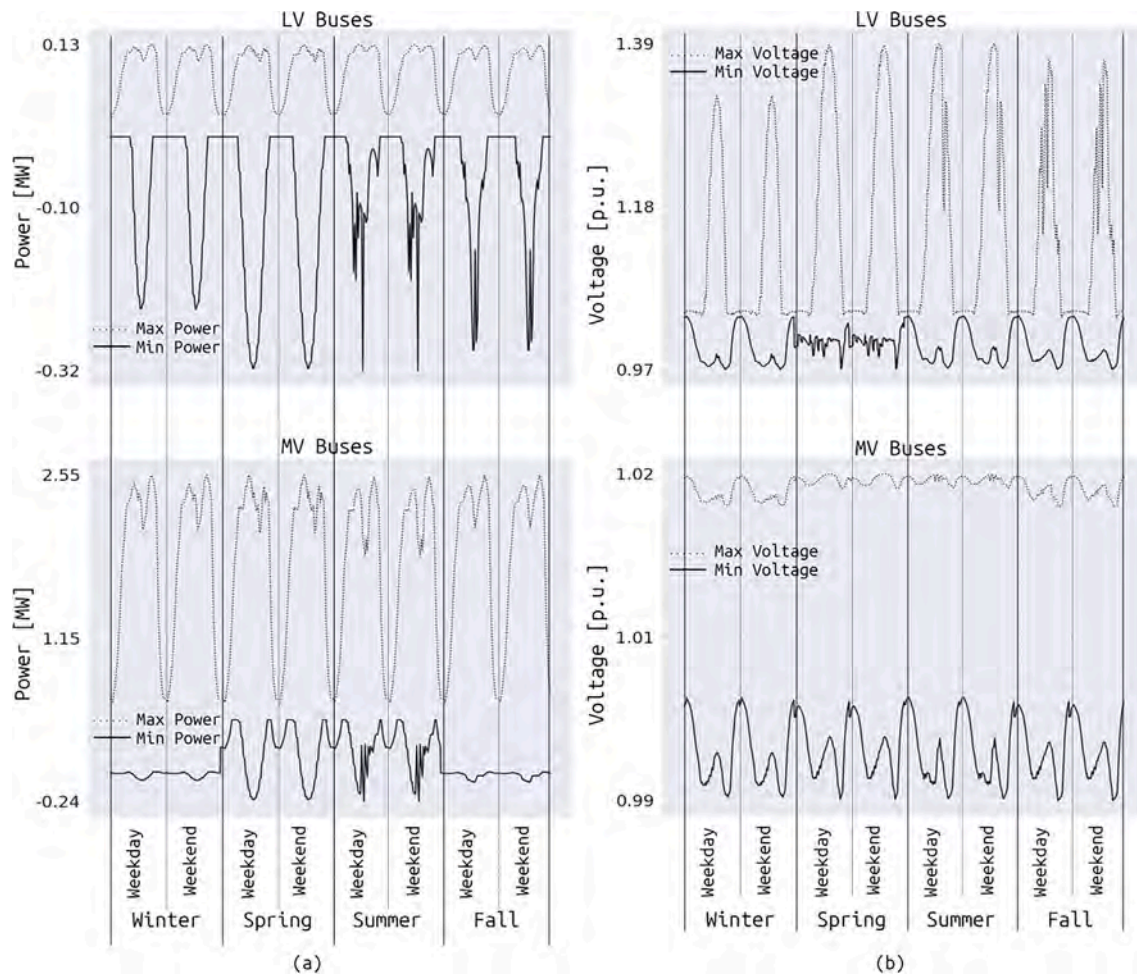

Fig. 14. Power flow results for two bus classes: (a) minimum and maximum power daily profiles and (b) minimum and maximum voltage daily profiles.

## 5. Conclusions

This paper presents a novel methodology for generating synthetic electricity networks within UES and evaluating the impact of deploying distributed PV generation systems on the grid. The proposed approach integrates GIS-based procedures, simulation techniques, and energy models to provide a comprehensive tool for analyzing electricity power flows at high spatio-temporal resolution.

One of the key strengths of this methodology lies in its ability to generate synthetic UES representations even when real-world data is limited. Additionally, these synthetic representations can be readily replaced with actual data when available, which enhances the accuracy and applicability of the platform. This adaptability allows for incorporating real-world data sources, such as building electricity consumption patterns or precise electrical grid topographies, leading to more precise and actionable results. The high spatio-temporal granularity of the data structure enables all the proposed detailed analyses, which integrate GIS-based procedures for assessing energy generation and consumption with grid management procedures. The methodology is adaptable to diverse urban settings and boundary definitions, and it is capable of generating synthetic representations of UES.

Our platform supports a range of applications, including the creation and management of Energy Communities, optimizing energy usage for individual households, aiding in urban planning, and assisting utility companies in grid management. This adaptability ensures the solution can be used by a variety of stakeholders to evaluate different scenarios and design effective control strategies, enhancing grid resilience and

fostering sustainable energy practices. Several users and applications can benefit from this infrastructure, including Energy Communities, which can evaluate different scenarios and test different aggregations, or Distribution System Operators, which can use it for network balancing and planning grid extensions.

The proposed infrastructure offers a system capable of supporting both operational and planning activities. The platform is impartial to diverse regulations, installation/maintenance costs, incentives, and energy market prices. Reasoning at the infrastructure level introduces a novel concept of spatial aggregation that goes beyond traditional political boundaries. Simulating the area connected to each substation promotes the creation of Energy Communities and local electricity self-consumption. This approach can be instrumental in reducing the strain on the transmission grid and addressing complications arising from excess injected electricity. Managing reverse power flow, line congestion, and over-voltage problems poses specific challenges that need to be addressed to ensure network stability and reliability. While this study excluded storage systems to focus on the direct impacts of PV integration and did not aim to dimension an Energy Community, future research will incorporate storage technologies. This will enable a detailed evaluation of their potential flexibility to mitigate grid challenges and optimize Energy Communities' operations.

To enhance the distribution grid's operation and efficiency and support increased PV DG system penetration, stakeholders can use insights from our tool. Upgrading grid infrastructure, such as lines and transformers, can manage increased loads and mitigate overvoltage. Advanced

load management strategies, like demand response programs, can balance demand and supply by shifting energy usage to high PV generation times. Integrating storage systems, such as batteries, can store excess energy during peak production and release it during low generation or high demand, stabilizing the grid by smoothing out supply and demand variations.

Our solution serves as a valuable tool for evaluating the impact of a distributed PV system on the electricity grid. The proposed platform can help grid managers and operators identify and address potential safety and security issues associated with the integration of distributed energy systems. By modelling various scenarios, our tool enables the proactive management of grid stability, and the identification and visualisation of the precise section of the electricity network where complications, such as reverse power flow, line congestion, and over-voltage problems, may arise. These findings offer numerous insights that can be used to develop and implement effective control strategies to mitigate these problems. For example, the methodology can be used to determine the optimal size of PV panels to deploy or the need to reinforce grid lines.

This study focuses on analyzing a single substation in detail. This demonstrates the applicability of the methodology at an infrastructural level. The approach is inherently scalable. It can be replicated over larger regions by applying the same simulation structure to multiple substations. However, such expansions fall outside the scope of this work. Similarly, demand-response strategies show potential for improving grid adaptability. Their analysis, though, is beyond the objectives of this study. The proposed framework prioritizes versatility and adaptability, laying a solid foundation for broader applications in future research.

While this methodology does not explicitly propose solutions to all network problems, it provides the technical foundation for conducting such analyses. These analyses are of paramount importance as they can be used to evaluate the impact of different control strategies on the grid, such as load shifting, Demand Side Management, or Demand Response. This information can then be used to design and implement effective control strategies that ensure the stability and reliability of the grid.

In conclusion, while our current focus is on PV systems, our model is designed to be extensible. In future work, we plan to include other renewable energy systems, such as wind and hydro, leveraging similar approaches to handle their specific data requirements. This extensibility will allow us to integrate a broader range of renewable energy sources into our simulations seamlessly, enhancing the versatility and applicability of our platform. Regarding the impact of different climate conditions, such as cooling-dominant versus warming-dominant climates, our current model includes plans for future work to simulate the thermal behavior of buildings equipped with HVAC systems. In future studies, we plan to expand our analysis to include detailed assessments of the environmental benefits and drawbacks of widespread PV DG system adoption. This will involve a comprehensive evaluation of the emission factors and their prospective evolution to accurately estimate the impact on the carbon footprint of the electrical grid.

#### CRediT authorship contribution statement

**Marco Massano:** Writing – original draft, Visualization, Validation, Software, Formal analysis, Data curation, Conceptualization. **Carlos Mateo Domingo:** Writing – review & editing, Software, Methodology, Data curation. **Enrico Macii:** Writing – review & editing, Supervision. **Edoardo Patti:** Writing – review & editing, Supervision, Methodology, Conceptualization. **Lorenzo Bottaccioli:** Writing – review & editing, Writing – original draft, Visualization, Validation, Supervision, Software, Methodology, Investigation, Conceptualization.

#### Declaration of competing interest

The authors declare the following financial interests/personal relationships which may be considered as potential competing interests:

Lorenzo Bottaccioli reports was provided by Polytechnic of Turin. Lorenzo Bottaccioli reports a relationship with Polytechnic of Turin that

includes: employment. If there are other authors, they declare that they have no known competing financial interests or personal relationships that could have appeared to influence the work reported in this paper.

#### Acknowledgement

This manuscript is part of the project NODES which has received funding from the MUR-M4C2 1.5 of PNRR funded by the European Union - NextGenerationEU (Grant agreement no. ECS00000036).

#### Data availability

Data will be made available on request.

#### References

- [1] United Nations, Paris agreement, in: UN Climate Change Conference (COP21), 2015.
- [2] European Commission, The EU clean energy package, Off. J. Eur. Union (2019).
- [3] G. Dóci, E. Vasileiadou, A.C. Petersen, Exploring the transition potential of renewable energy communities, *Futures* 66 (2015) 85–95.
- [4] European Parliament, Directive (EU) 2018/2001 of the European Parliament and of the Council of 11 December 2018 on the promotion of the use of energy from renewable sources, Off. J. Eur. Union (2018).
- [5] T. Connolly, B. College, *Understanding GIS: The ARC/INFO Method*, second ed., ESRI Press, 1998.
- [6] B. Resch, G. Sagl, T. Törnros, A. Bachmaier, J.-B. Eggers, S. Herkel, S. Narmsara, H. Gündra, Gis-based planning and modeling for renewable energy: challenges and future research avenues, *ISPRS Int. J. Geo-Inf.* 3 (2) (2014) 662–692.
- [7] M.Q. Duong, T. Le, T.H. Tran, T.M.C. Le, N.T.N. Tran, Challenge of modern photovoltaic systems under large-scale forms to distribution grid in preinstallation and operation: Vietnam study case evaluation, in: *Performance Enhancement and Control of Photovoltaic Systems*, Elsevier, 2024, pp. 259–283.
- [8] M. Massano, E. Macii, A. Lanzini, E. Patti, L. Bottaccioli, A GIS open-data co-simulation platform for photovoltaic integration in residential urban areas, *Engineering* (2022). <https://doi.org/10.1016/j.eng.2022.06.020>.
- [9] F. Ceglia, P. Esposito, E. Marrasso, M. Sasso, From smart energy community to smart energy municipalities: literature review, agendas and pathways, *J. Clean. Prod.* 254 (2020) 120118.
- [10] P. Esposito, E. Marrasso, C. Martone, G. Pallotta, C. Roselli, M. Sasso, M. Tufo, A roadmap for the implementation of a renewable energy community, *Heliyon* 10 (7) (2024).
- [11] S. Soltan, G. Zussman, Generation of synthetic spatially embedded power grid networks, arXiv:1508.04447, 2015.
- [12] K.P. Schneider, B. Mather, B. Pal, C.-W. Ten, G.J. Shirek, H. Zhu, J.C. Fuller, J.L.R. Pereira, L.F. Ochoa, L.R. de Araujo, et al., Analytic considerations and design basis for the IEEE distribution test feeders, *IEEE Trans. Power Syst.* 33 (3) (2017) 3181–3188.
- [13] K. Strunz, S. Barsali, Z. Styczynski, Developing benchmark models for integrating distributed energy resources, in: *Power Engineering Society General Meeting*, 2006.
- [14] G. Pretticco, N. Andreadou, S. Vitiello, *Distribution System Operators Observatory 2020*, Publications Office of the European Union, 2021.
- [15] Y. Liao, Y. Weng, G. Liu, R. Rajagopal, Urban MV and LV distribution grid topology estimation via group lasso, *IEEE Trans. Power Syst.* 34 (1) (2018) 12–27.
- [16] A.B. Birchfield, E. Schweitzer, M.H. Athari, T. Xu, T.J. Overbye, A. Scaglione, Z. Wang, A metric-based validation process to assess the realism of synthetic power grids, *Energies* 10 (8) (2017). <https://www.mdpi.com/1996-1073/10/8/1233>.
- [17] S. Soltan, G. Zussman, Generation of synthetic spatially embedded power grid networks, in: *2016 IEEE Power and Energy Society General Meeting (PESGM)*, IEEE, 2016, pp. 1–5.
- [18] G. Pisano, N. Chowdhury, M. Coppo, N. Natale, G. Petretto, G.G. Soma, R. Turri, F. Pilo, Synthetic models of distribution networks based on open data and georeferenced information, *Energies* 12 (2019) 4500. <https://doi.org/10.3390/en12234500>.
- [19] E. Schweitzer, A. Scaglione, A mathematical programming solution for automatic generation of synthetic power flow cases, *IEEE Trans. Power Syst.* 34 (1) (2019) 729–741. <https://doi.org/10.1109/TPWRS.2018.2863266>.
- [20] J. Amme, G. Pleßmann, J. Bühler, L. Hülk, E. Kötter, P. Schwaegerl, The eGo grid model: an open-source and open-data based synthetic medium-voltage grid model for distribution power supply systems, *J. Phys. Conf. Ser.* 977 (2018) 012007.
- [21] C.M. Domingo, T.G. San Roman, A. Sanchez-Mirallas, J.P.P. Gonzalez, A.C. Martinez, A reference network model for large-scale distribution planning with automatic street map generation, *IEEE Trans. Power Syst.* 26 (1) (2010) 190–197.
- [22] S.A. Salimon, G.A. Adepoju, I.G. Adebayo, H.O.R. Howlader, S.O. Ayanlade, O.B. Adewuyi, Impact of distributed generators penetration level on the power loss and voltage profile of radial distribution networks, *Energies* 16 (4) (2023) 1943.
- [23] P. Szcześniak, P. Powroźnik, E. Sztajmec, Selected voltage control methods in LV local distribution grids with high penetration of PV, *Prz. Elektrotech.* 99 (2023) 62–65.
- [24] A.M. Soliman, S.M. Emara, M.N. Nashed, Grid performance enhancement study under restricted placement and sizing of PV distributed generation, *J. Electr. Eng. Technol.* 18 (1) (2023) 229–237.
- [25] D. Horak, A. Hainoun, G. Neugebauer, G. Stoeglehner, A review of spatio-temporal urban energy system modeling for urban decarbonization strategy formulation.

- Renew. Sustain. Energy Rev. 162 (2022) 112426. <https://doi.org/10.1016/j.rser.2022.112426>.
- [26] M.R. Maghami, J. Pasupuleti, C.M. Ling, Impact of photovoltaic penetration on medium voltage distribution network, *Sustainability* 15 (7) (2023) 5613.
- [27] L. Bottaccioli, E. Patti, E. Macii, A. Acquaviva, Gis-based software infrastructure to model PV generation in fine-grained spatio-temporal domain, *IEEE Syst. J.* 12 (3) (2017) 2832–2841.
- [28] L. Bottaccioli, S. Di Cataldo, A. Acquaviva, E. Patti, Realistic multi-scale modeling of household electricity behaviors, *IEEE*. Access 7 (2018) 2467–2489.
- [29] L. Thurner, A. Scheidler, F. Schäfer, J. Menke, J. Dollichon, F. Meier, S. Meinecke, M. Braun, Pandapower – an open-source python tool for convenient modeling, analysis, and optimization of electric power systems, *IEEE Trans. Power Syst.* 33 (6) (2018) 6510–6521. <https://doi.org/10.1109/TPWRS.2018.2829021>.
- [30] Eurostat, Harmonised European Time Use Surveys (HETUS) 2018 guidelines, 2019, <https://ec.europa.eu/eurostat/web/products-manuals-and-guidelines/-/ks-gq-19-003>.
- [31] OpenStreetMap Contributors, Planet dump retrieved from <https://planet.osm.org>, <https://www.openstreetmap.org>, 2017.
- [32] C. Mateo, F. Postigo, F. de Cuadra, T.G. San Roman, T. Elgindy, P. Dueñas, B.-M. Hodge, V. Krishnan, B. Palmintier, Building large-scale US synthetic electric distribution system models, *IEEE Trans. Smart Grid* 11 (6) (2020) 5301–5313.
- [33] S. Petridis, O. Blanas, D. Rakopoulos, F. Stergiopoulos, N. Nikolopoulos, S. Voutetakis, An efficient backward/forward sweep algorithm for power flow analysis through a novel tree-like structure for unbalanced distribution networks, *Energies* 14 (4) (2021). <https://www.mdpi.com/1996-1073/14/4/897>.
- [34] J.-H. Teng, A direct approach for distribution system load flow solutions, *IEEE Trans. Power Delivery* 18 (3) (2003) 882–887. <https://doi.org/10.1109/TPWRD.2003.813818>.
- [35] C.E. Italiano, Caratteristiche della tensione fornita dalle reti pubbliche di distribuzione dell'energia elettrica, 2012.
- [36] ISTAT, Italian general censuses of population and housing, 2011. <https://www.istat.it/en/archive/196131>.
- [37] Città di Torino, Piano d'azione per l'energia sostenibile, 2022. [http://www.comune.torino.it/ambiente/bmdoc/report\\_terzo\\_monitoraggio\\_ec1.pdf](http://www.comune.torino.it/ambiente/bmdoc/report_terzo_monitoraggio_ec1.pdf).
- [38] Regione Piemonte, Geoportale del Piemonte, 2021. <http://www.geoportale.piemonte.it/>.