

Pesticide spraying systems for vineyards using drones

Original

Pesticide spraying systems for vineyards using drones / Raparelli, Terenziano; Ivanov, Alexandre; Eula, Gabriella. - In: INTERNATIONAL JOURNAL OF MECHANICS AND CONTROL. - ISSN 1590-8844. - ELETTRONICO. - 25:2(2024), pp. 53-60. [10.69076/jomac.2024.0028]

Availability:

This version is available at: 11583/2997408 since: 2025-02-10T12:25:14Z

Publisher:

ASTRA M B

Published

DOI:10.69076/jomac.2024.0028

Terms of use:

This article is made available under terms and conditions as specified in the corresponding bibliographic description in the repository

Publisher copyright

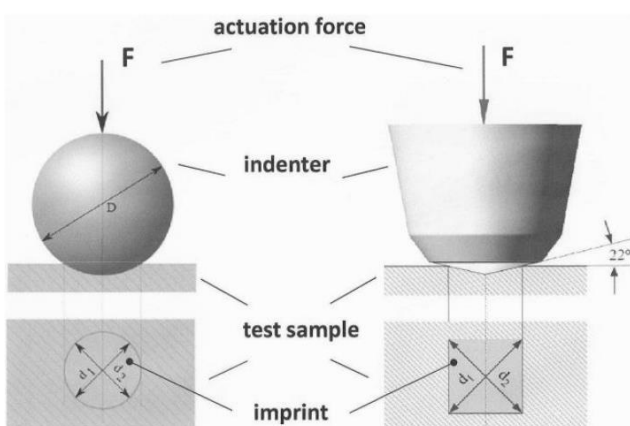
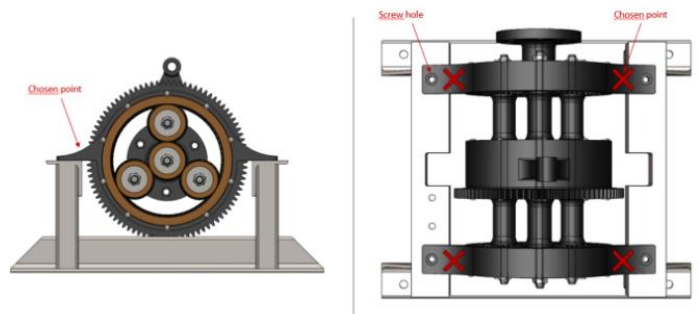
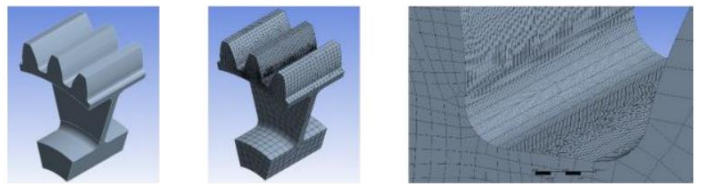
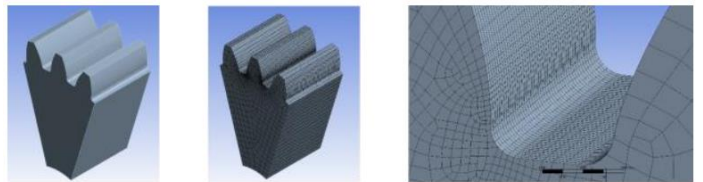
(Article begins on next page)

International Journal of Mechanics and Control

Editor: **Andrea Manuello Bertetto**

Scopus Indexed Journal

Reference Journal of IFToMM Italy
International Federation for the Promotion
of Mechanism and Machine Science



International Journal of Mechanics and Control

Associate Editors

Published by ASTRA M B S.R.L. – Torino – Italy E.C.

Honorary editors

Guido Belforte

Kazuo Yamafuji

Editor:

Andrea Manuello Bertetto

General Secretariat:

Matteo D. L. Dalla Vedova

Simone Venturini

Alessandro Aimasso

Mario Acevedo
Universidad Panamericana
Mexico City – Mexico

Giovanni Boschetti
University of Padova
Vicenza – Italy

Luca Bruzzone
Università degli Studi di Genova
Genova – Italy

Giuseppe Carbone
University of Calabria
Rende – Italy

Marco Ceccarelli
University of Cassino
Cassino – Italy

Matteo Davide Lorenzo Dalla Vedova
Politecnico di Torino
Torino – Italy

Francesca Di Puccio
University of Pisa
Pisa – Italy

Carlo Ferraresi
Politecnico di Torino
Torino – Italy

Alexey Fomin
Mechanical Engineering Research Institute of the Russian
Academy of Sciences (IMASH RAN)
Moscow – Russia

Walter Franco
Politecnico di Torino
Torino – Italy

Rafael Lopez Garcia
University of Jaen
Jaen – Spain

Viktor Glazunov
Mechanical Engineering Research Institute of the Russian
Academy of Sciences (IMASH RAN)
Moscow – Russia

Rogério Sales Gonçalves
Federal University of Uberlândia
Uberlândia – Brazil.

Kenji Hashimoto
Waseda University
Tokyo – Japan

Giovanni Jacazio
Politecnico di Torino
Torino – Italy

Juan Carlos Jauregui Correa
Universidad Autonoma de Queretaro
Queretaro – Mexico

Med Amine Laribi
University of Poitiers
Poitiers – France.

Paolo Maggiore
Politecnico di Torino
Torino – Italy

Mingfeng Wang
Brunel University
London – United Kingdom

Paolo Emilio Lino Maria Pennacchi
Politecnico di Milano
Milano – Italy

Giuseppe Quaglia
Politecnico di Torino
Torino – Italy

Aleksandar Rodic
Institute Mihajlo Pupin
Belgrade – Serbia

Shuangji Yao
Yanshan University
Qinhuangdao – China

Mauro Velardocchia
Politecnico di Torino
Torino – Italy

Renato Vidoni
Free University of Bolzano
Bolzano – Italy

Ion Visa
Transilvania University of Brasov
Brasov – Romania

Yu-Hsun Chen
National Taiwan University of Science and Technology
Taipei City – Taiwan

Jaroslav Zapomel
VSB - Technical University of Ostrava
Ostrava - Czech Republic

Leon Zlajpah
Jozef Stefan Institute
Ljubljana – Slovenia

Official Torino Italy Court Registration
n. 5390, 5th May 2000

Deposito presso il Tribunale di Torino
n. 5390 del 5 maggio 2000

Direttore responsabile:

Andrea Manuello Bertetto

PESTICIDE SPRAYING SYSTEMS FOR VINEYARDS USING DRONES

Terenziano Raparelli*

Alexandre Ivanov**

Gabriella Eula*

* Department of Mechanical and Aerospace Engineering, Politecnico of Torino – Torino – Italy

** former of Department of Mechanical and Aerospace Engineering, Politecnico of Torino – Torino – Italy

ABSTRACT

The use of drones in agriculture is often applied to the pesticide spraying processes as they allow to avoid the compaction of the tractor on the soil, to reduce the dispersion of the pesticide in the air in comparison with other aerial vehicle used in agriculture, to improve the operator safety during the treatment as he can work not in contact with the pesticide. This paper presents a numerical and an experimental study in the spraying process of the pesticides in the vineyards using drones. The analysis employed a numerical model of the airflows generated by the drone, as well as some experimental tests conducted in a purpose-built wind tunnel. This numerical study evidences the airflow trajectories and turbulences under the drone and their influence on the sprayer nozzles functioning. The simulations were then furthermore verified and analysed by means of a specific experimental bench, made of a wind tunnel and some parts simulating the drone rotors and the nozzles. The results were promising and can be used to select the optimal drone operating conditions and nozzle location for a proper pesticide distribution on the crop.

Keywords: pesticide spraying techniques using drones; pesticide spraying system for vineyards; drones used to spray pesticide in vineyards; Unmanned Aerial Vehicle (UAV); drones for precision farming

1 INTRODUCTION

With the gradual transition to precision farming and Agriculture 4.0 in recent years, new technologies have been introduced to improve the agricultural sector's efficiency. One such technology is the use of small, remotely controlled Unmanned Aerial Vehicles (UAVs), commonly known as drones [1, 2]. However, new technologies must be adapted to the specific needs of the agro-industrial complex, since using UAVs also entails its own problems, both technical and legal [3].

Drones in modern agriculture are used for multiple purposes, from soil scanning and crop health monitoring to the application of fertilizers, pesticides and herbicides.

Drones equipped with multispectral or RGB cameras process the visible and near infrared light reflected from the crop, providing information on crop health through appropriate analysis and processing

In [4] the relationships between the Normalized Difference Vegetation Index (NDVI) and different crop status indices to obtain information that can be applied in precision agriculture are investigated, while other studies based on the evaluation of vegetation indices are presented in [5-7]. A similar approach to detecting disease on vine leaves using drone images is presented in [8].

Other studies of drones equipped with sensors capable of acquiring images to create accurate three-dimensional models of crops are presented in [9-11]

UAVs are widely used to distribute pesticides by means of spray nozzles positioned on the underside of the drone [12, 13]. They undoubtedly have a number of advantages: the entire working cycle with the exception of filling the pesticide tank can be performed autonomously without personnel, crops on steep slopes can be sprayed [14], and the soil compaction that takes place when working with tractors is avoided.

Applying pesticides on trees and bushes has its own specific requirements [15-17], since spraying must be carried out mainly in a vertical plane.

This is also true of using UAVs in vineyards [18, 19], where a number of special factors must be taken into account.

Powerful airflows are formed as UAVs move [19]. These airflows act on the atomized substances and can distort or completely alter the trajectory of the pesticide droplets

Contact author: Gabriella Eula¹

¹Dept. of Mechanical and Aerospace Engineering,
Politecnico di Torino, Torino, Italy
E-mail: gabriella.eula@polito.it

(particles) released by the spray nozzles. On the other hand, these flows can create a positive effect, assisting pesticide delivery to the plant. This paper investigates techniques for spraying pesticides in the vineyard using drones in order to reduce pesticide losses and improve vine coverage. The study focused on espalier-trained vineyards and, drawing on previous work [20], a quadcopter drone design. The study's aim was thus to optimize the position of the spray nozzles. To this end, a numerical model of the airflows generated by the quadcopter was constructed, analyzed and tested experimentally.

The originality of this study is the investigation on this new application of drones in agriculture with some advantages in the pesticide spraying techniques in comparison with the traditional use of the tractors, such as: no stress and no weight on the soil, reduction of the possible pesticide diffusion. In the air as the distance of the drone flight is less than those required with others aerial vehicles, safety for the operator for the more distance from the spraying circuit, possible better distribution of the product on the crop.

2 MATERIAL AND METHODS

The modelled vineyard is espalier-trained as shown in Figures 1a and b, with the quadcopter flying above and between the rows of vines [21]. Rows are 2.10 m tall and spaced 2.40 m apart [22]. This flight pattern is preferred for vineyards located on slopes, [23], although in other cases it is possible to work across the rows [24]. So the two options for quadcopter flight during spraying are shown in Figures 1 [22]: above each row a) and between the rows b). The selected quadcopter [25] ensures a vertical and horizontal hovering accuracy of ± 0.1 m (with a strong GNSS signal and D-RTK enabled). As the flight can be continually corrected above the espalier posts along the flight path, option a) seems preferable. The quadcopter featured four 0.766 m diameter carbon fiber rotor blades [26], located at the vertices of a 1 x 1 m square as shown in Figure 2a. The ANSYS Fluent was used for all numerical simulation, the experiment model for wind tunnel and drone will be described below.

3 RESULTS AND DISCUSSION

3.1 NUMERICAL MODEL AND RESULTS

ANSYS Fluent software with the $k-\epsilon$ turbulence model for compressible gas was used as a numerical model building tool [27]. The quadcopter in its working volume is shown in Figure 2a. The green rectangle inside the volume represents the area to be sprayed (all illustrations are for illustrative purposes only, as the volume of the article and page size do not allow for detailed graph). Air velocity distributions in the drone zone were obtained for different rotor rotation and displacement speeds.

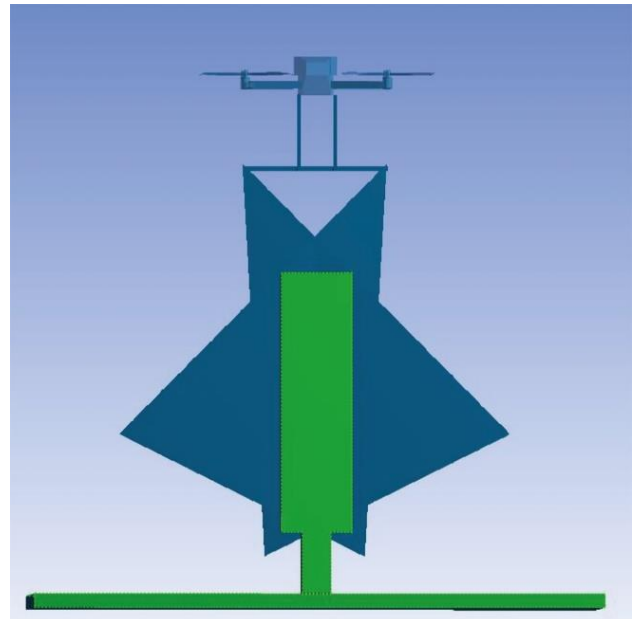


Figure 1a The quadcopter flight during spraying, above the row.

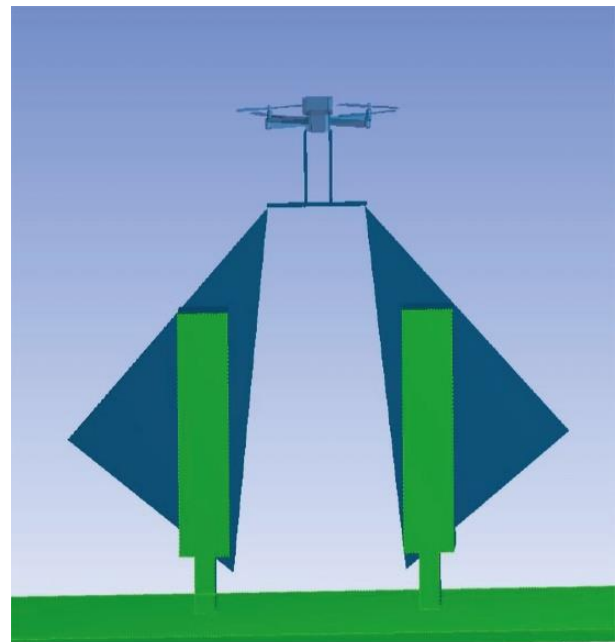


Figure 1b The quadcopter flight during spraying between the rows.

Figure 2b shows an example of pathlines generated by drone movement, coloured according to the modulus of airflow velocity. In this case, rotor directions of rotation are: front left-clockwise, front right-counterclockwise, rear left-counterclockwise, rear right-clockwise. This choice is typical for most commercial quadcopters [28, 29], although other directions of rotation are possible.

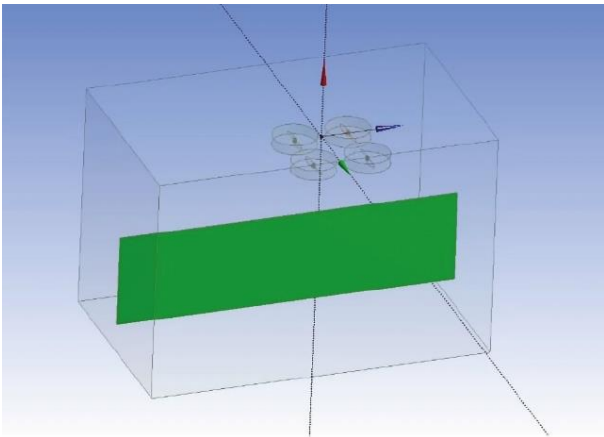


Figure 2a Numerical model schematics.

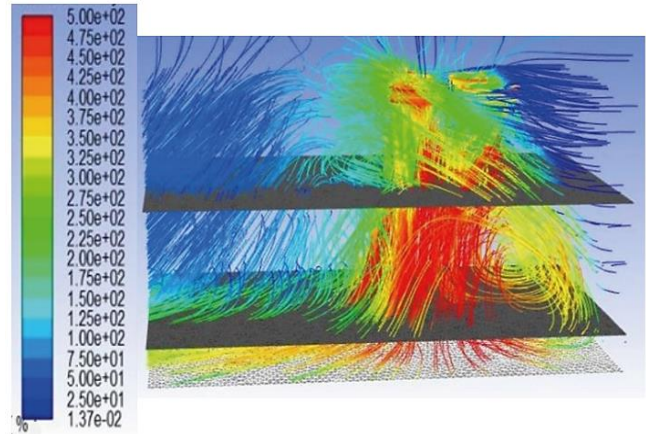


Figure 3 Pathlines coloured according to turbulence intensity (%).

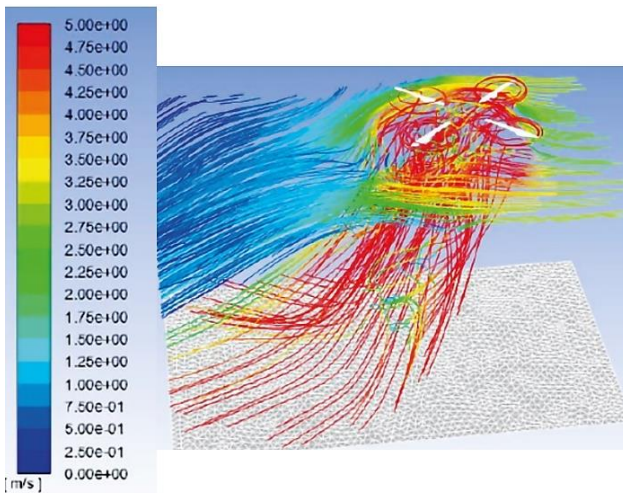


Figure 2b An example of air flow pathlines, coloured according to the modulus of velocity (m/s).

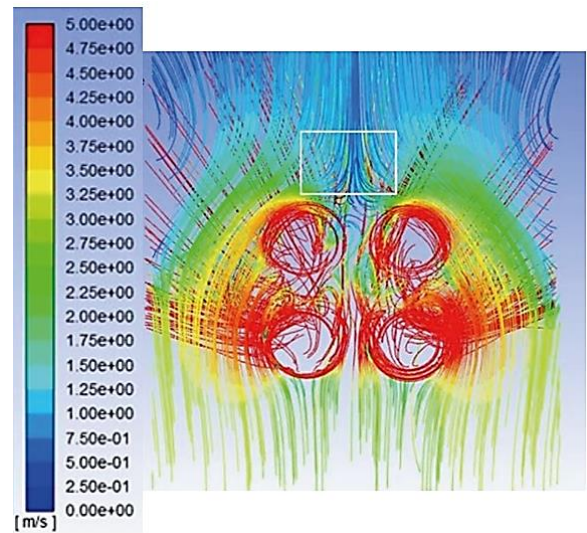


Figure 4 Top view of pathlines starting 0.50 m below the rotor planes (m/s).

When selecting the location of the pesticide spray nozzle, three parameters were taken into account: air flow velocity; trajectory curvature; turbulence intensity. The air flow velocity along a curved trajectory cannot be very high [15], since otherwise it will lead to separation of the pesticide droplets leaving the nozzle. If the trajectories are strongly curved, the inertial force acts with greater intensity on large particles than on small ones, which can cause flow stratification. The magnitude of the turbulence intensity, i.e. the ratio of the average turbulent velocity to the average velocity, is also an important factor for particle distribution. In the droplet spray zone, the turbulence intensity should not be very high, since otherwise it can lead to droplet stratification and significant dispersion. However, high turbulence intensity can be beneficial in the grape leaf zone, since it causes their movement, which facilitates pesticide deposition.

Thus, to select the optimal location of the nozzles, the intensity of turbulence in the quadcopter zone was analyzed taking into account the trajectory of the flow line, as shown in Figure 3. In the case under consideration, the characteristic values were taken to be 5 m/s and 25% intensity. The black planes represent the top and bottom of the vine rows.

Figure 4 represents the pathlines around the quadcopter as seen from above. A portion of the pathlines starting 0.50 m below the rotor is shown. This level was selected as a possible nozzle installation position on the quadcopter. As can be seen from Figure 4, the zone framed in a white rectangle features low airflow velocity and low pathline curvature. This area can thus be considered as a candidate spray nozzle location for drones following the flight path shown in Figure 1a. As for the drone overflight pattern represented in Figure 1b, Figures 3 and 4 show that all the areas where the pathlines are facing outward are in close proximity to the ground, making it difficult to use this flight path.

4 EXPERIMENTAL TESTS

The numerical model was validated using the composite modeling method [30]. Here, a downscaled copy of the real object is used for physical, mathematical and experimental models. Experimental data from the scale model experiments

are compared with data obtained with the mathematical model. If this data matches well, the results also extend to the main model. A 0.25 kg quadcopter with 0.145 m diameter propellers having a center-to-center distance of 0.17 m was used as an experimental model (drone Snaptain S5C from Snaptain Amazon.it). The drone was secured in a wind tunnel measuring 1.20 x 0.53 x 0.62 m (L x W x H) as shown in Figure 5, at a height of 0.53 m, which corresponds to a real flight at a height of 3.1 m (measured along the plane of the propellers). The direction of air movement in this case is towards the fan (fan with air flowrate range from 0.1 to 1 m³/s ANR).



Figure 5 The drone in the wind tunnel.

The numerical model was tested separately for the drone and the empty wind tunnel.

The first step was to check the possibility of using a wind tunnel for the task. For this purpose, numerical simulation of air flow in a wind tunnel was carried out and the obtained results were compared with experimental data for the measured flow speeds. After it was found that the calculated results coincided well with the experimental ones, a section with a flow heterogeneity not exceeding 5% of the flow speed was selected in the wind tunnel, in which the drone and the target representing the vineyard were subsequently placed.

The second step was to measure quadcopter rotor speed. An oscilloscope with a photodiode attached to its input (arrowed in Figure 6a) was used for this purpose (Tektronix TDS 2014B Oscilloscope from Tektronix Oregon U.S.A.). The change in luminous flux caused by propeller rotation was recorded by the oscilloscope, and the rotation frequency (5500 rpm, 576 rad/s) was used in the numerical model. Next, the lift (Figure 6b) determined with the numerical model was compared [31] with the quadcopter's weight, showing good agreement. Using numerical nozzle simulation [32] is complex, and it is not possible to simply scale the nozzle sizes geometrically. In the tests carried out, a jet of coloured fluid was used at a constant speed to visualize droplet flow. With the quadcopter in the wind tunnel, a vertical wall was positioned to representing the scale model of the vine row. After activating the wind tunnel and quadcopter motors, the coloured water (the colour used

was normal ink) was sprayed into the model from a fixed known position and at a known angle.

During the tests, the coloured water jet was used at a low speed of 1 m/s.

Tests were conducted with wind tunnel air velocities of 0.5 and 3 m/s, measured with an anemometer (Proster anemometer from Proster Store, model TL 017, range 0 ÷ 30 m/s, resolution 0,1 m/s), varying the nozzle position.

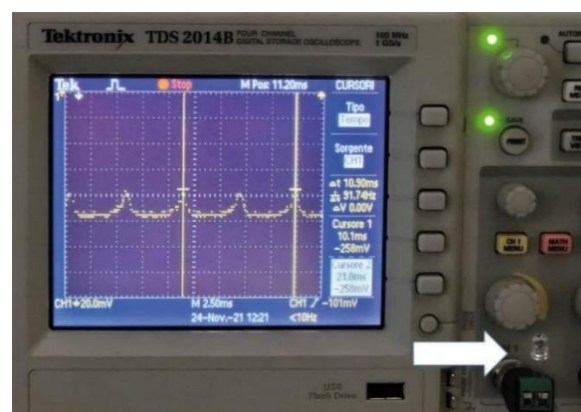


Figure 6a The signal of the oscilloscope with a photodiode.

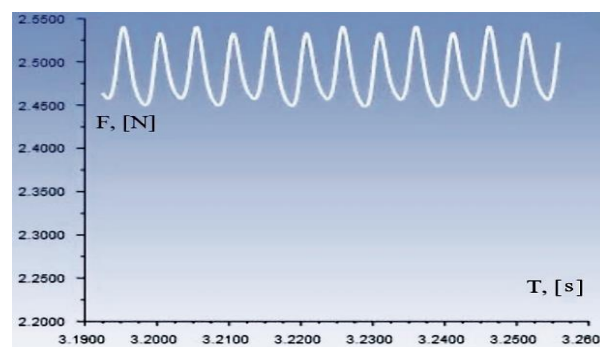


Figure 6b The lift graph.

Figures 7a and b show which parameters were changed during the wind tunnel experiments. These are the horizontal distance of the ejector from the plane of the axes of the rear propellers L , their vertical distance from the plane of the location of the propellers H and the distance from the longitudinal plane of symmetry of the quadcopter to the ejector S . All distances in the calculations were normalized to the distance between the nearest propellers, i.e. 0.17 m.

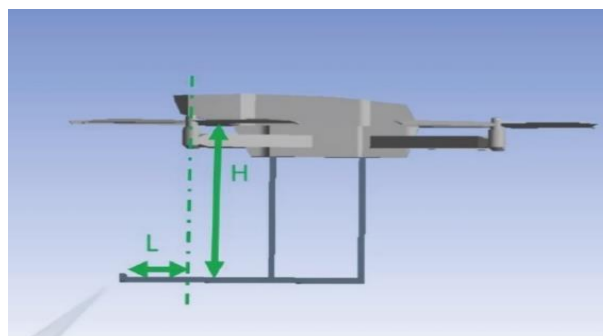


Figure 7a Spray nozzles positioning.

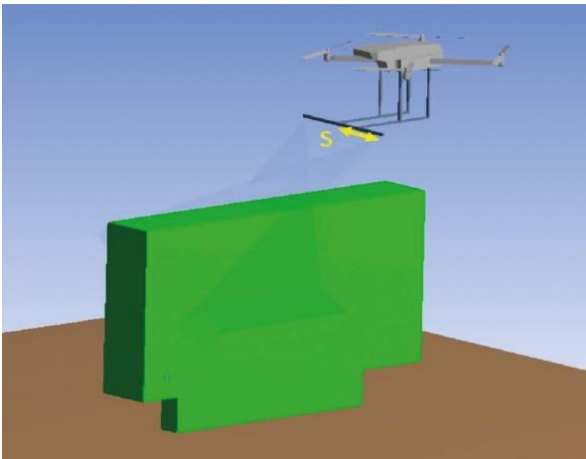


Figure 7b The Quadcopter, the spray nozzles and the vineyard.

unit the distance between the axes of the nearest propellers is taken (0.17 m). The nozzle is placed at the rear of the drone at longitudinal positions (L) corresponding to 0.70; 0.60; 0.45 and 0.30 (rows 1; 2; 3 and 4, respectively). The distance to the quadcopter longitudinal axis (S) and the propeller plane of rotation (H) was 0.5 (all dimensionless parameters). The first column in Figure 8 shows the pathlines coloured according to the velocity modulus, with a scale of 0 to 5 m/s. The second column shows the pathlines coloured according to turbulence intensity, scale 0-100%, while the third column shows images left by the coloured liquid, which falls on the target (Figure 2a, the green rectangle inside the volume represents the area to be sprayed). The location of the traces left by colored water, presented in the third column of Figure 9, corresponds to their position on the graphs shown in the first and second columns, that is, both the scale and the physical coordinates of the points on these graphs coincide. As can be seen from the Figure 8, there is a good match between the numerical and experimental data for both location and behaviour. Liquid dispersion increases along with turbulence intensity.

Results for airflow velocity at 0.5 m/s are shown in Figure 8, where all images correspond to the same area and are at the same scale. Dimensionless parameters are used, where per

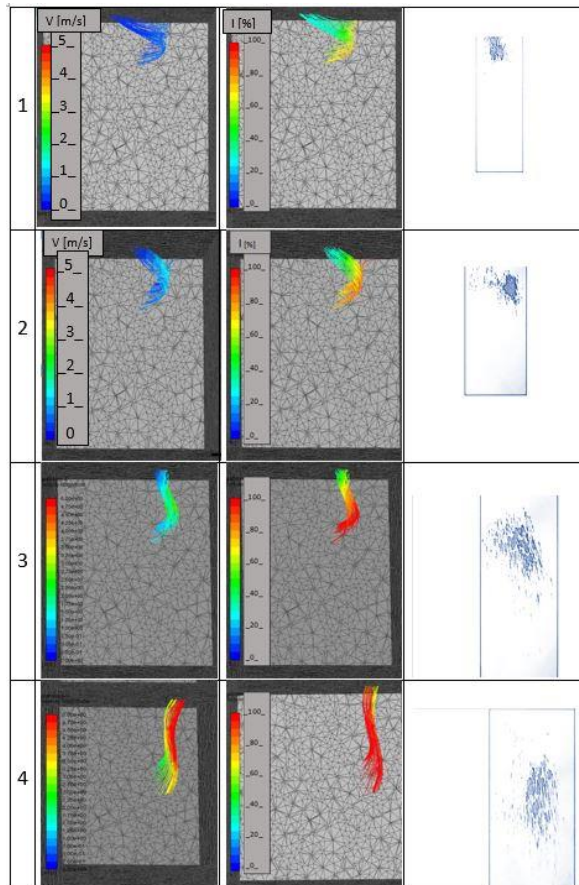


Figure 8 Pathlines coloured according to velocity modulus (m/s) and turbulence intensity (%); experimental tests with coloured liquid (column on the right).

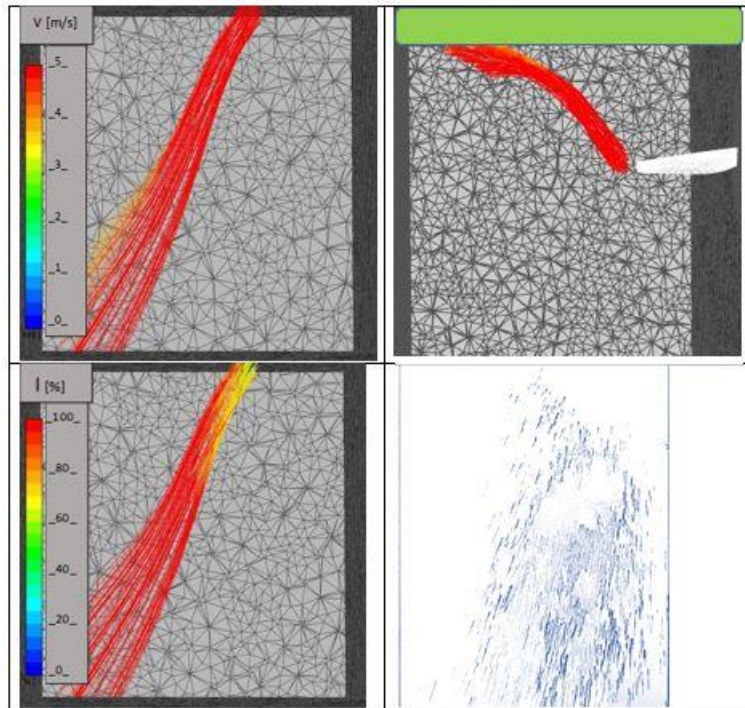


Figure 9 Top row: pathlines coloured according to velocity modulus (0-5 m/s): left - side view and right - top view; bottom row: left-pathlines coloured according to turbulence intensity (0-100%), right-test result.

Figure 9 presents the case corresponding to Line 3 in Figure 8, but with an airflow speed of 3 m/s.

The top row presents the pathlines coloured according to the 0-5 m/s velocity modulus (side view on the left, top view on the right, the green strip represents the location of the vine row).

The bottom row shows the pathlines coloured according to the turbulence intensity (0-100%) and the experimental data. As can be seen from Figure 9, the experimental results are consistent with the results obtained using the model for 3 m/s airflow velocity. Experimental tests were conducted at airflow velocities of 0.5 and 3 m/s, changing the positions of the nozzles along the quadcopter axis and the distance from the axis. The results of numerical simulations in all cases corresponded well to those obtained experimentally. Figures 10 show pathlines coloured according to the velocity modulus for a quadcopter with a propeller center-to-center distance of 1 m. Figures 10 show the rear view (a) and side view (b) of the distribution of streamlines, colored according to the modulus of airflow velocity generated by the propellers of the quadcopter.

As noted above, when placing ejectors in the zone of pathlines directed towards the plane of symmetry of the copter, liquid drops from the ejector are directed to this zone. In the case of a quadcopter for vineyard treatment, this means that the sprayed liquid will be concentrated in the treatment area and not leave it.

The control of the intensity of turbulence in the analysis of the obtained results also makes it possible to estimate the scattering of liquid drops, since, as can be seen from the experimental data, with an increase in the intensity of

turbulence, the scattering of drops also increases. Quadcopters with similar parameters are widely used for agricultural applications [25, 26]. The pathlines coloured according to the velocity modulus start from a zone located 0.5 m from the plane of the axes of the rear propellers and at 0.5 m from the propeller plane of rotation. Placing the nozzles in the area framed by a white rectangle and spraying down-back-center as was presented in Figures 7 makes it possible to bring the pesticide to the desired target area on the vine row at low speed.

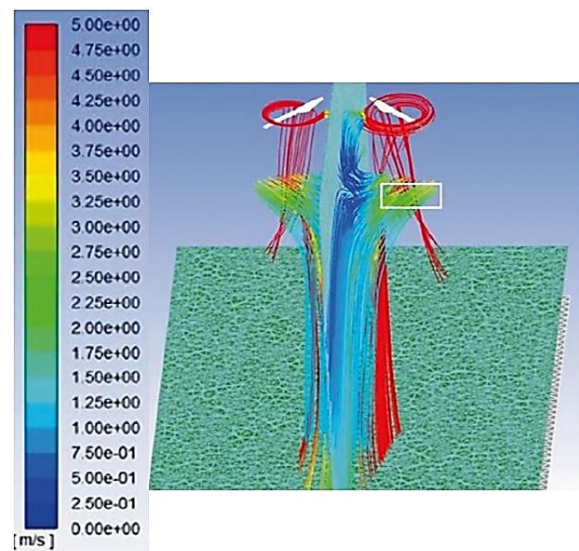


Figura 10a Pathlines coloured according to velocity modulus (m/s): a rear view.

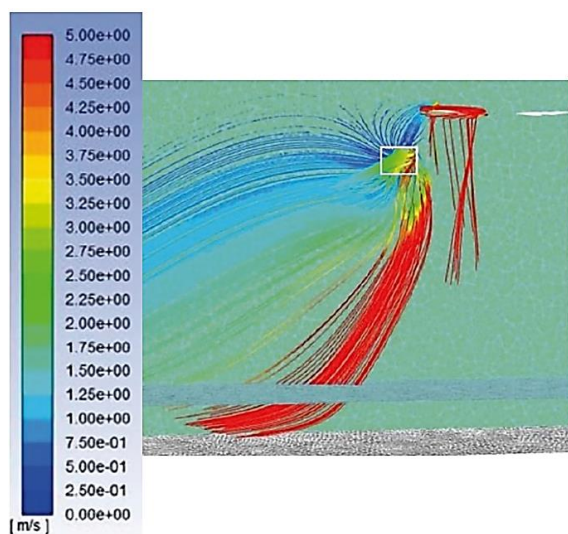


Figure 10b Pathlines coloured according to velocity modulus (m/s): a side view.

5 CONCLUSIONS

In this paper a mathematical model and experimental tests on the use of a quadcopter in the pesticide spraying treatments in the vineyard were presented. Some important and interesting results were obtained. Using digital modeling, an analysis of the air flows generated by the quadcopter was carried out and zones for the optimal placement of spray nozzles were identified. The obtained results were verified using composite modeling. For this purpose, a comparison was made of the experimental results obtained for a reduced quadcopter model with the calculated results obtained for this model. Good agreement between the experimental and theoretical results for the scaled-down quadcopter model confirmed the feasibility of the mathematical model used to analyze the quadcopter use for vineyard. The technique presented here, which employs a mathematical model for a quadcopter and a downscaled experimental copy of it, can also be used to analyse the drone behaviour in various working conditions, including crosswinds, headwinds and the drone roll. The results obtained are good and interesting both from the numerical study and from the experimental tests. Some further interesting tests can be now carried out in their laboratory by the authors on some agricultural sprayer nozzles without the drone, in order to improve the knowledge on the sprayed jets, considering the droplets diameters, the coverage area and the droplets density in a vineyard simulator constructed in a scale 1:1. In these experimental conditions the sprayer circuit can be fixed and the results obtained can be compared with those presented in this paper, in order to know the real effect of the drone rotors and movement on the spraying conditions. So all these considerations are useful to study the influence of the drone rotors and movement on the spraying nozzles jets. This allows to improve the treatment with pesticide using drones, reducing the dispersion of the product in the air and in the soil and improving the spraying techniques on the crops.

Furthermore the use of the drone avoids the stress on the soil not using a tractor and flying from a low distance from the culture. The next stage of the investigation will involve testing a quadcopter with installed nozzles, flying directly on a vineyard. This will also allow to evaluate the accuracy of the digital model used when increasing the size of the quadcopter.

ACKNOWLEDGMENTS

This research was financed with Italian MIUR funds in the PRIN Project 2017 “New technical and operative solutions for the use of drones in Agriculture 4.0” (Research projects of significant national interest).

REFERENCES

- [1] Tsouros D.C., Bibi S. and Sarigiannidis P.G., A Review on UAV-Based Applications for Precision Agriculture. *Information* 349, Vol 10, No. 11, pp.1-26, 2019.
- [2] Cocuzza S. and Doria A., Experimental vibration analysis and development of the dynamic model of a uav for aerial manipulation. *International Journal of Mechanics and Control*, Vol. 22, No. 2, pp. 71-82, 2021.
- [3] Del Cerro J., Ulloa C.C., Barrientos A. and De León Rivas J., Unmanned Aerial Vehicles in Agriculture: A Survey. *Agronomy* 203, Vol. 11. No. 2, pp.1-19, 2021.
- [4] Vega F.A., Ramírez F.C., Saiz M.P. and Rosúa F.O., Multi-temporal imaging using an unmanned aerial vehicle for monitoring a sunflower crop. *Biosystems Engineering*, Vol. 132, pp.19-27, 2015.
- [5] Lan Y.B. and Chen S.D., Current status and trends of plant protection UAV and its spraying technology in China. *Int J Precis Agric Aviat*, Vol. 1, No. 1, pp. 1-9, 2018.
- [6] Berni J.A.J., Zarco-Tejado P.Y., Suárez L., Gonzales-Dugo V. and Fereres E., Remote sensing of vegetation from UAV platforms using lightweight multispectral and thermal imaging sensors. *Int Arch Photogramm Remote Sens. Spatial Inform. Sci*, Vol. 38. No. 6, pp. 1-6, 2009.
- [7] Jannoura R., Brinkmann K., Uteau D., Bruns C. and Joergensen R.G., Monitoring of crop biomass using true colour aerial photographs taken from a remote controlled hexacopter. *Biosystems Engineering*, Vol. 129, pp. 341-351, 2015.
- [8] Kerkech M., Hafiane A. and Canals R., Deep leaning approach with colorimetric spaces and vegetation indices for vine diseases detection in UAV images. *Computers and Electronics in Agriculture*, Vol. 155, pp. 237-243, 2018.
- [9] Comba L., Biglia A., Riccauda Aimonino D., Barge P., Tortia C. and Gay P., Enhanced Vineyard Descriptors combining UAV 2D and 3D Crop Models. Proceedings of the New Engineering Concepts for Valued Agriculture. *Proceedings of European Conference on*

- Agricultural Engineering AgEng 2018*, Wageningen University The Netherlands 8th -12th July 2018, pp. 49-56, 2018.
- [10] Bietresato M., Carabin G., Vidoni R., Gasparetto A. and Mazzetto F., Evaluation of a LiDAR-based 3D-stereoscopic vision system for crop-monitoring applications. *Computers and Electronics in Agriculture*, Vol. 124, pp. 1-13, 2016.
- [11] Mack J., Lenz C., Teutrine J. and Steinhage V., High-precision 3D detection and reconstruction of grapes from laser range data for efficient phenotyping based on supervised learning. *Computers and Electronics in Agriculture*, Vol. 135, pp. 300-311, 2017.
- [12] Chen P., Lan Y., Huang X., Qi H., Wang G., Wang J., Wang L. and Xiao H., Droplet Deposition and Control of Planthoppers of Different Nozzles in Two-Stage Rice with a Quadrotor Unmanned Aerial Vehicle. *Agronomy* 303, Vol. 10, No. 2, pp.1-14, 2020.
- [13] Martin D., Singh V., Latheef M.A. and Bagavathiannan M., Spray Deposition on Weeds (Palmer Amaranth and Morningglory) from a Remotely Piloted Aerial Application System and Backpack Sprayer. *Drones* 59, Vol. 4, No. 3, pp. 1-18, 2020.
- [14] Marinello F., Pezzuolo A., Chiumenti A. and Sartori L. Technical analysis of unmanned aerial vehicles (drones) for agricultural applications. *15th International Scientific Conference on Engineering for rural development*, Vol. 15, No. 2, pp. 870-875, 2016.
- [15] Chojnacki J. and Pachuta A., Impact of the Parameters of Spraying with a Small Unmanned Aerial Vehicle on the Distribution of Liquid on Young Cherry Trees. *Agriculture* 1094, Vol. 11, No. 11, pp. 1-13, 2021.
- [16] Qin W.C., Xue X.Y., Cui L.F., Zhou Q.Q., Xu Z.F. and Chang F.L., Optimization and test for spraying parameters of cotton defoliant sprayer. *Int J Agric & Biol Eng.*, Vol. 9, No. 4, pp. 63–72, 2016.
- [17] Martinez-Guanter J.M., Agüera P., Agüera J. and Perez-Ruiz M., Spray and economics assessment of a UAV-based ultra-low-volume application in olive and citrus orchards. *Precision Agriculture*, Vol. 21, pp. 226–243, 2020.
- [18] Chen H.B., Lan Y.Bz., Fritz B.K., Hoffmann W.C. and Liu S.B., Review of agricultural spraying technologies for plant protection using unmanned aerial vehicle (UAV). *Int J Agric & Biol Eng*, Vol. 14, No. 1, pp. 38–49, 2021.
- [19] Tang Q., Zhanga R., Chena L., Dengb W., Xub M., Xub G. and Lib L., Andrew Hewitt. Numerical simulation of the downwash flow field and droplet movement from an unmanned helicopter for crop spraying. *Computers and Electronics in Agriculture* 105468. Vol. 174, pp. 1-14, 2020.
- [20] Raparelli T., Eula G., Ivanov A. and Pepe G., Macchinari agricoli per l'irrorazione di prodotti fitosanitari in vigneto e loro sviluppo. *Oleodinamica Pneumatica*, April, pp. 22-26, 2021.
- [21] Raparelli T., Eula G., Ivanov A. and Pepe G., Ugelli e sistemi di irrorazione per vigneti montati su droni. *Oleodinamica Pneumatica*, April, pp. 28-32, 2021.
- [22] Raparelli T., Eula G., Ivanov A. and Pepe G., Project of an experimental simulator designed to analyse pesticide spraying techniques in vineyard using drones. *International Journal of Mechatronics and Applied Mechanics*, Vol. 1, No. 10, pp. 64-71, 2021.
- [23] Sarri D., Martelloni L., Rimediotti M., Lisci R., Lombardo S. and Vieri M., Testing a multi-rotor unmanned aerial vehicle for spray application in high slope terraced vineyard. *Journal of Agricultural Engineering*, Vol. 50, No. 1, pp. 38-47, 2019.
- [24] Wang C., Herbst A., Zeng A., Wongsuk S., Qiao B., Qi P., Bonds J., Overbeck V., Yangf Y., Gao W. and He X., Assessment of spray deposition, drift and mass balance from unmanned aerial vehicle sprayer using an artificial vineyard, *Science of the Total Environment* 146181, Vol. 777, pp. 1-14, 2021.
- [25] AGRAS T10. *User Manual V.1.4. DJI*. ALL rights Reserved, 2021, <https://www.dji.com/t10/downloads>, Accessed on [2022-01-20].
- [26] Wen S., Hanb J., Ning Z., Lan Y., Yin X., Zhang J. and Ge Y., Numerical analysis and validation of spray distributions disturbed by quad-rotor drone wake at different flight speeds. *Computers and Electronics in Agriculture* 105036, Vol. 166, pp. 1-21, 2019.
- [27] Yang S.H., Tang Q., Zheng Y.J., Liu X.X., Chen J. and Li X.L., Model migration for CFD and verification of a six-rotor UAV downwash. *Int J Agric & Biol Eng.*, Vol. 13, No. 4, pp. 10–18, 2020.
- [28] Wen S., Zhang Q., Deng J., Lan Y., Yin X., and Shan J., Design and Experiment of a Variable Spray System for Unmanned Aerial Vehicles Based on PID and PWM Control. *Appl. Sci. (Special Issue Advanced Mobile Robotics 2482)*, Vol. 8, No. 12, pp. 1-22, 2018.
- [29] Chen Y.Y., Hou C.J., Tang Y., Zhuang J.J., Lin J.T. and Luo S.M., An effective spray drift-reducing method for a plant-protection unmanned aerial vehicle. *Int J Agric & Biol Eng.*, Vol. 12, No. 5, pp. 14–20, 2019.
- [30] Gerritsen H., Sutherland J., Deigaard R., Sumer M., Fortes C.J.E.M., Sierra J.P. and Schmidtke U., Composite modelling of interactions between beaches and structures, *Journal of Hydraulic Research* 49 (Issue sup1: *HYDRALAB III: LARGE-SCALE EXPERIMENTS AND COMPOSITE MODELLING*), Vol. 39, Issue sup 1, pp. 2-14, 2011.
- [31] Lei Y. and Cheng M., Aerodynamic Performance of Hex-Rotor UAV Considering the Horizontal Airflow. *Appl. Sci.* 4797, Vol. 9, No. 22, pp. 1-11, 2019.
- [32] Kashani A., Parizia H. and Mertins K.H., Multi-step spray modelling of a flat fan atomizer. *Computers and Electronics in Agriculture* 144, pp. 58–70, 2018.

International Journal of Mechanics and Control – JoMaC
Published by ASTRA M B S.R.L.
TRANSFER OF COPYRIGHT AGREEMENT

<p>NOTE: Authors/copyright holders are asked to complete this form signing section A, B or C and mail it to the editor office with the manuscript or as soon afterwards as possible.</p>	<p><i>Editorial Secretary address:</i> Andrea Manuello Bertetto Matteo D. L. Dalla Vedova, Simone Venturini, Alessandro Aimasso <i>Dept. of Mechanical and Aerospace Engineering</i> <i>Politecnico di Torino</i> <i>C.so Duca degli Abruzzi, 24 – 10129 Torino – Italy</i> <i>e_mail: jomac@polito.it</i> <i>fax n.: +39.011.090.6999</i></p>
--	--

The article title:

By: _____

To be Published in *International Journal of Mechanics and Control JoMaC*
Official legal Turin court registration Number 5320 (5 May 2000) - reg. Tribunale di Torino N. 5390 del 5 maggio 2000

A Copyright to the above article is hereby transferred to the JoMaC, effective upon acceptance for publication. However the following rights are reserved by the author(s)/copyright holder(s):

1. All proprietary rights other than copyright, such as patent rights;
2. The right to use, free or charge, all or part of this article in future works of their own, such as books and lectures;
3. The right to reproduce the article for their own purposes provided the copies are not offered for sale.

To be signed below by all authors or, if signed by only one author on behalf of all co-authors, the statement A2 below must be signed.

A1. All authors:

SIGNATURE _____ DATE _____ SIGNATURE _____ DATE _____

PRINTED NAME _____ PRINTED NAME _____

SIGNATURE _____ DATE _____ SIGNATURE _____ DATE _____

PRINTED NAME _____ PRINTED NAME _____

A2. One author on behalf of all co-authors:

"I represent and warrant that I am authorised to execute this transfer of copyright on behalf of all the authors of the article referred to above"

PRINTED NAME _____

SIGNATURE _____ TITLE _____ DATE _____

B. The above article was written as part of duties as an employee or otherwise as a work made for hire. As an authorised representative of the employer or other proprietor. I hereby transfer copyright to the above article to *International Journal of Mechanics and Control* effective upon publication. However, the following rights are reserved:

1. All proprietary rights other than copyright, such as patent rights;
2. The right to use, free or charge, all or part of this article in future works of their own, such as books and lectures;
3. The right to reproduce the article for their own purposes provided the copies are not offered for sale.

PRINTED NAME _____

SIGNATURE _____ TITLE _____ DATE _____

C. I certify that the above article has been written in the course of employment by the United States Government so that no copyright exists, or by the United Kingdom Government (Crown Copyright), thus there is no transfer of copyright.

PRINTED NAME _____

SIGNATURE _____ TITLE _____ DATE _____

CONTENTS - Special Issue of the International Journal of Mechanics and Control (JoMaC) dedicated to the 6th International Tunisian Conf. on Mechanics (COTUME 2023)

- 01 **Preface Special Issue – Guest Editorial**
G. Carbone, M.A. Laribi, T. Bouraoui, A. Znaidi, T. Benameur, N. Ben Moussa, F. Zemzmi, R. Ennetta, N. Aifaoui
- 03 **Human-robot interoperability for end of life disassembly lines of mechatronic products**
I. Belhadj, M.Aicha, M. Hammadi, N. Aifaoui
- 09 **Design for selective assembly and disassembly process optimization**
A. Allagui, I. Belhadj, R. Plateaux, M. Hammadi, O. Penas, N. Aifaoui
- 15 **A new LAsQEM and LaWQEM approaches for stability and free vibration analysis of a strain gradient elastic euler-bernoulli**
M. A. Argoubi, M. Trabelssi, M. Hili Chiboub
- 33 **Design of experiments for numerical simulations on the NiTi orthodontic archwires superelastic behaviour**
M. Laroussi, H. Gzara, T. Bouraoui
- 39 **Effect of friction coefficients and extrapolation laws on springback prediction of HSLA420 steel**
S. Ben-Elechi, S. Shiri, M. Guerich
- 47 **The influence of 3D printing process parameters in the dimension accuracy, roughness, and weight**
N. Ben Hariz, A. Boulila, M. Ayadi

CONTENTS – Regular Issue

- 53 **Pesticide spraying systems for vineyards using drones**
T. Raparelli, A. Ivanov, G. Eula
- 61 **Some proposals for modelling the main components of a drone-mounted vineyard pesticide sprayer circuit**
T. Raparelli, N. Filippi, G. Eula
- 77 **Synthesis method of algorithms for dynamic state estimation of maneuvering objects based on quasi-optimal motion models using reduction of the Lagrange problem**
A. A. Kostoglotov, A. S. Penkov
- 87 **Strain fields and bending crack failure analysis in standard and thin-rim spur gears using the digital image correlation method**
F. M. Curà, A. Mura, L. Corsaro
- 95 **Electrical bioimpedance and mechanical penetrometry tests for remotely detecting the tissue damage due to mis-management of the cold chain in oblong red chicory**
A. Manuello Bertetto, A. Fois, F. Tocco, F. Velluzzi, A. Deledda, F. Farris, D. Vacca, G. Picci, A. H. Dell’Osa, R. Marcello, S. Melis, A. Concu
- 113 **Biomechanical and cardiometabolic changes in a skilled kayaker after 41 days of cruising around the island of Sardinia: a case study (Part 1)**
F. Tocco, M. Massidda, G. Ghiani, M. Palmas, M. Ruggiu, F. Velluzzi, R. Solinas, A. Masala, A. Fois, L. Melis, A. Manuello Bertetto, A. H. Dell’Osa, A. Cerina, C. Cappagli, S. Melis, V. Loi, R. Marcello, A. Concu
- 121 **Use of optical sensors for electro-mechanical actuators torque estimation**
A. Aimasso, P. C. Berri, M. Bertone, M. D. L. Dalla Vedova

NEWS FROM THE JOMAC EDITORIAL BOARD:

Starting from the June 2024 issue, JoMaC provides an Open Access service to our authors.
You are invited to visit the JoMaC website (<http://www.jomac.it>) for further details.