

Accurate resistance comparators with ratiometric digital multimeters

Original

Accurate resistance comparators with ratiometric digital multimeters / Ortolano, M., Marzano, M., Durandetto, P., D'Elia, V., Enrico, E., Callegaro, L. - ELETTRONICO. - (2024), pp. 1-2. (Conference on Precision Electromagnetic Measurements (CPEM) Denver, CO (USA) 08-12 July 2024) [10.1109/cpem61406.2024.10646107].

Availability:

This version is available at: 11583/2992337 since: 2024-09-10T07:43:39Z

Publisher:

IEEE

Published

DOI:10.1109/cpem61406.2024.10646107

Terms of use:

This article is made available under terms and conditions as specified in the corresponding bibliographic description in the repository

Publisher copyright

IEEE postprint/Author's Accepted Manuscript

©2024 IEEE. Personal use of this material is permitted. Permission from IEEE must be obtained for all other uses, in any current or future media, including reprinting/republishing this material for advertising or promotional purposes, creating new collecting works, for resale or lists, or reuse of any copyrighted component of this work in other works.

(Article begins on next page)

Accurate resistance comparators with ratiometric digital multimeters

M. Ortolano¹, M. Marzano², P. Durandetto², V. D'Elia², E. Enrico², and L. Callegaro²

¹Politecnico di Torino, Torino, Italy

massimo.ortolano@polito.it

²Istituto Nazionale di Ricerca Metrologica INRIM, Torino, Italy

Abstract—This summary paper describes and characterizes two resistance comparators exploiting long-scale digital multimeters operating in ratiometric mode and compares the results obtained in the measurement of resistance ratios of $12.906 \text{ k}\Omega : 10 \text{ k}\Omega$ and $10 \text{ k}\Omega : 1 \text{ k}\Omega$ against those obtained with a direct current comparator. The comparators herewith described are suitable for primary resistance metrology with accuracy at the 10^{-8} – 10^{-7} level, depending on the resistance ratio.

Index Terms—Metrology, calibration, electrical resistance measurement

I. INTRODUCTION

The DC realization of the ohm from the quantum Hall effect and its dissemination from National Metrology Institutes (NMIs) to calibration laboratories require accurate resistance comparators.

Cryogenic current comparators (CCCs) can compare resistance standards with the best accuracy to date, at the 10^{-9} level, but may not be afforded by small NMIs and by most calibration laboratories due to their cost and complexity of operation in a cryogenic environment. Room-temperature direct current comparators (DCCs) are simpler to operate and can compare resistances at the 10^{-8} level but, though less expensive than CCCs, they still may not be afforded by many calibration laboratories. The potentiometric method [1], [2] can also be employed to compare resistances at the 10^{-8} level. However, the implementation of this method requires high-isolation switches and stable voltage or current sources. The potentiometric method has been simplified by employing digital multimeters (DMMs) (see e.g. [3], [4] for relatively recent examples), but stable current sources and high-isolation switches are still needed.

In [5], [6] we presented a simpler system for 1 : 1 ratios, with an accuracy of a few parts in 10^8 , using the ratiometric operation of a Keysight 3458A. Since the voltages across the two resistance standards in this setup are measured in quick succession, the stability requirement of the driving current source is less demanding with respect to other published comparators.

Here we report the performance of the system for ratios up to 1 : 10, determining the nonlinearity of the 3458A in ratio measurements against a programmable Josephson voltage standard (PJVS). We also present a similar approach with the DMM Fluke 8588A.

II. COMPARATOR SETUP AND MEASUREMENT MODEL

Fig. 1 shows the schematic diagram of the resistance comparator with the DMM Keysight 3458A directly measuring the

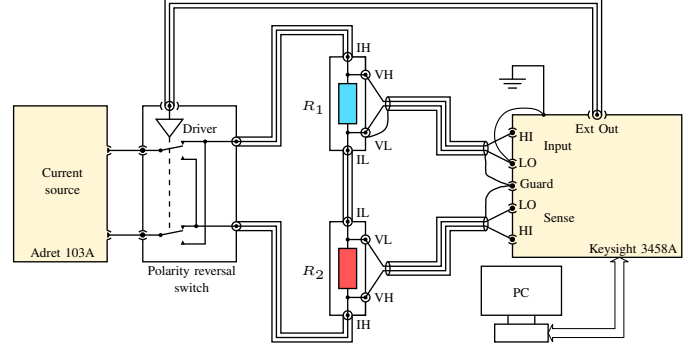

Fig. 1. Schematic diagram of the comparator with the two resistors R_1 and R_2 connected in the forward configuration.

voltage ratio between the input and sense terminals. The two four-terminal resistance standards under comparison, R_1 and R_2 , are connected in series at the low current terminals and driven at the high current terminals by an Adret Electronique 103A programmable current source. The voltage terminals of R_1 and R_2 are connected to the DMM input and sense terminals: to compensate the DMM gain error, R_1 and R_2 are first connected in the *forward* configuration, as shown in Fig. 1; then, in the *reverse* configuration, the two standards are exchanged. The current direction is periodically reversed by a switch controlled by the DMM Ext Out signal to eliminate the offset error. The resistance ratio is determined according to the model

$$\frac{R_1}{R_2} = \frac{\sqrt{Q^F/Q^R}}{1 + \epsilon + \frac{1}{2}(R_2 - R_1)(R_{11}^{-1} + R_{12}^{-1})}, \quad (1)$$

where Q^F is the average of the measurements in the forward configuration, Q^R is the average for the reverse configuration, ϵ is a term accounting for the DMM nonlinearity and the transfer uncertainty between the forward and reverse configurations, and R_{11} and R_{12} are the DMM input resistances at the input and sense terminals, respectively.

The setup with the Fluke 8588A is simpler because this DMM can directly measure resistance ratios, with an internal connection similar to that of Fig. 1. However, also in this case we exchange the resistances to compensate for the gain errors of the two channels and, as discussed in Sec. III, this improves the measurement accuracy.

To achieve the best accuracy, the voltage measurements at the input and sense terminals should be performed in the same range. This limits the 3458A setup to a ratio of about 1 : 10 due to the autoranging feature that cannot be disabled when

TABLE I
RESULTS OF THE COMPARISON OF THE DMM-BASED RESISTANCE COMPARATORS AND A DCC.

Ratio	δ^{DCC}	I^{DCC}	δ^{3458A}	I^{3458A}	δ^{8588A}	I^{8588A}	$\delta^{3458A} - \delta^{\text{DCC}}$	$\delta^{8588A} - \delta^{\text{DCC}}$
	$\mu\Omega \Omega^{-1}$	μA	$\mu\Omega \Omega^{-1}$	μA	$\mu\Omega \Omega^{-1}$	μA	$\mu\Omega \Omega^{-1}$	$\mu\Omega \Omega^{-1}$
12.906 k Ω : 10 k Ω	-112.55(1)	50	-112.69(3)	50	-112.83(25)	100	-0.14(3)	-0.28(25)
10 k Ω : 1 k Ω	54.42(1)	50	53.76(44)	10	53.86(44)	10	-0.66(44)	-0.56(44)
10 k Ω : 1 k Ω	54.82(7)	10			55.28(38)	10		0.46(39)

the DMM measures the voltage at the sense terminals; the 8588A setup can instead operate at higher ratios.

III. RESULTS

The resistance ratio measurements obtained with both DMM setups were compared with those of a DCC (Measurements International AccuBridge 6010D), considered as reference. Table I reports the results for two ratio measurements, 12.906 k Ω : 10 k Ω and 10 k Ω : 1 k Ω . The quantity δ represents the relative deviation of the measured ratio value with respect to the nominal ratio: the superscript labels either the result with the DCC, that with the 3458A setup or that with the 8588A setup. For the 12.906 k Ω : 10 k Ω , the DCC measurement was performed by individually measuring the 12.906 k Ω and the 10 k Ω standards against a 1 k Ω transfer standard. The reported standard uncertainties are the type A components only. These were evaluated for each average ratio measurement from the Allan deviation of the data points. For both the 3458A and the 8588A setups, the ratio noise can be considered as white noise. The duration of the measurements is about 4.5 h for the 3458A setup and 1.5 h–3 h for the 8588A setup. All results but one are compatible with the DCC results within the type A uncertainty, for a coverage factor $k = 2$. The individual forward or reverse measurements deviate instead by one or two parts in 10^6 , for both the 3458A and the 8588A setups. Thus, the exchange of the resistance standards is actually effective in improving the overall accuracy, beyond the DMMs specifications.

For what concerns the other sources of uncertainty, the main one is the nonlinearity of the DMM, between the forward and reverse configurations, represented by ϵ in (1). We performed a preliminary measurement of the nonlinearity of the 3458A by generating reference voltage ratios from a PJVS and a calibrated Fluke 732B direct voltage standard, used as 1.018 V fixed reference. The measurement procedure is as follows: i) the PJVS is connected to the input terminals of the 3458A and the 732B to the sense terminals, with like polarity and the low potential terminals of the 3458A grounded; ii) the polarities of the PJVS and of the 732B are manually reversed, while the ground is kept at the low potential terminals of the 3458A; iii) and iv) like i) and ii) but connecting the PJVS

to the sense terminals of the 3458A and the 732B to the input terminals. The measured ratios are then averaged and combined according to the numerator of (1). Table II reports the results of this characterization for voltage ratios 1 : 1, 1.2906 : 1 and 5 : 1. The quantity $\delta_{3458A} - \delta_{\text{REF}}$ is the relative deviation of the measured ratio with respect to the generated ratio by the PJVS and the 732B.

IV. CONCLUSION AND OUTLOOK

The results show that the simple resistance comparators herewith presented, assembled from instrumentation of popular use in test and measurement laboratories, can achieve accuracy performances in line with those of specialized primary resistance bridges. A full evaluation of the uncertainty is in progress and will be presented at the conference. However, taking into account the preliminary results presented in [5], [6] and those presented in this work, it can be tentatively concluded that these setups can compare resistance standards at the 10^{-8} level for 1 : 1 ratios and at the 10^{-7} level for ratios up to 10 : 1. The operating resistance range is also under investigation, but taking into account the input resistances of both DMMs it is reasonable to consider an upper limit of about 100 k Ω at the above stated level of uncertainty.

ACKNOWLEDGEMENT

This work has been supported by the project CAPSTAN *Quantum electrical Italian national capacitance standard* funded by the MIUR *Progetti di Ricerca di Rilevante Interesse Nazionale* (PRIN) Bando 2020, grant 2020A2M33J.

REFERENCES

- [1] L. Blik *et al.*, “High precision measurements of the quantized Hall resistance at the PTB,” *IEE Proc. Sci. Meas. Tech.*, vol. IM-34, pp. 304–305, 1985.
- [2] G. Marullo Reedtz and M. E. Cage, “An automated potentiometric system for precision measurement of the quantized Hall resistance,” *J. Res. Natl. Bur. Std.*, vol. 92, pp. 303–310, 1987.
- [3] C. Rietveld and C. J. Van Mullem, “Uncertainty analysis of a DVM-based quantum Hall measurement set-up,” in *Conference on Precision Electromagnetic Measurements Digest CPEM 2000*, Sydney, NSW, Australia, 2000, pp. 90–91.
- [4] P. Svoboda, P. Chrobok, and P. Vašek, “A simple DMM-based measuring system for QHE resistance measurements,” in *2000 Conference on Precision Electromagnetic Measurements (CPEM 2000)*, Sydney, NSW, Australia, 2000, pp. 566–567.
- [5] M. Marzano, V. D’Elia, M. Ortolano, and L. Callegaro, “A resistance comparator based on a long-scale digital voltmeter,” in *2022 Conference on Precision Electromagnetic Measurements*, Wellington, New Zealand, 2022, pp. 1–2.
- [6] —, “A simple and accurate resistance comparator with a long-scale ratiometric digital multimeter,” in *26th IMEKO TC4 International Symposium and 24th International Workshop on ADC/DAC Modelling and Testing*, 2023, pp. 39–42.

TABLE II
NONLINEARITY OF THE KEYSIGHT 3458A IN VOLTAGE RATIO MODE.

Ratio	V^{732B}/V	V^{PJVS}/V	$\delta^{3458A} - \delta^{\text{REF}}$
1 : 1	1.018 188 59	1.018 188 59	-0.11
1.2906 : 1	1.018 188 59	0.788 901 86	0.10
5 : 1	1.018 188 59	0.203 637 72	0.33