

Conjointly active and passive modelings with deep neural networks as fully automated optimizations for upper-mid band 6G communications

*Original*

Conjointly active and passive modelings with deep neural networks as fully automated optimizations for upper-mid band 6G communications / Kouhalvandi, L., Matekovits, L.. - In: SCIENTIFIC REPORTS. - ISSN 2045-2322. - ELETTRONICO. - 14:1(2024). [10.1038/s41598-024-68011-8]

*Availability:*

This version is available at: 11583/2991911 since: 2024-08-24T09:52:34Z

*Publisher:*

Springer Nature

*Published*

DOI:10.1038/s41598-024-68011-8

*Terms of use:*

This article is made available under terms and conditions as specified in the corresponding bibliographic description in the repository

*Publisher copyright*

(Article begins on next page)



OPEN

# Conjointly active and passive modelings with deep neural networks as fully automated optimizations for upper-mid band 6G communications

Lida Kouhalvandi<sup>1</sup> & Ladislau Matekovits<sup>2,3,4</sup>✉

Today wireless systems include the fifth and sixth generations (5G and 6G) technologies and are growing day by day that result in exponentially increasing data traffic. For providing a reliable and high performance radio frequency (RF) designs especially for 6G networks, amplifiers and antenna as active and passive components play important roles. In the 5G/6G communication systems, the propagation loss is considerably large and its compensation requires high output power generated from the amplifiers for guaranteeing the satisfied quality of transmitted signal. From another point of view, the installed antennas must be able to optimally manage the radiated signals and handle/compensate nonlinear performances of the RF circuitry. Hence, advanced modeling and multi-objective optimization algorithms are required for designing and optimizing high performance amplifiers and antennas in terms of output power, gain, efficiency, linearity, and bandwidth. Concurrently optimizing active and passive components is not straightforward and typically it requires additional efforts by the RF designers. To tackle this drawback, a two-step methodology is proposed: (1) configuring the initial structure of active and passive devices, and (2) sizing the configured devices. In this work, various methods are introduced for structuring the topology of circuits and then artificial intelligence, including machine learning and neural networks, is preferred among other surrogate modelling for sizing the designs. These neural networks are satisfied due to the accurate modeling responses and are able to provide an automated optimization process leads to employ multi-objective optimization methods. In this work, an automated optimization process for comprehensive design of high-performance amplifiers with antennas through bottom-up optimization (BUO) method and long short-term memory (LSTM)-based deep neural networks (DNNs) is proposed. At the output layer of DNNs, the multi-objective multi-verse optimizer (MOMVO) method is employed for optimizing various specifications of active device (i.e., amplifier), and passive device (i.e., antenna), concurrently. In the presented method, all the electromagnetic (EM) design rules are implemented which results in reducing simulation time in the harmonic balance simulation environment that also provides ready to fabricate layouts. The novelty consists of the all-inclusive style that (1) reduces the manual breaks, aka time-to-market, and (2) delivers ready-to-fabricate layouts of the device that exhibits global optimum performances, automatically. The validation of the proposed method is verified by designing and optimizing high power amplifier (HPA) with antenna in the frequency band from 9.0 GHz to 9.6 GHz, suitable for upper-mid band 6G communications.

In the fifth generation (5G) and next-generation (i.e., sixth generation (6G)) communication systems, high-order modulations are playing important roles as they are useful for transferring high-data rate in the broadband

<sup>1</sup>Department of Electrical and Electronics Engineering, Dogus University, Istanbul 34775, Turkey. <sup>2</sup>Department of Electronics and Telecommunications, Politecnico di Torino, Turin 10129, Italy. <sup>3</sup>Istituto di Elettronica e di Ingegneria dell'Informazione e delle Telecomunicazioni, National Research Council of Italy, Turin 10129, Italy. <sup>4</sup>Faculty of Electronics and Telecommunications, Politehnica University Timișoara, Timișoara 300006, Romania. ✉email: ladislau.matekovits@polito.it

complex radio frequency (RF) systems<sup>1–4</sup>. The 5G technology is developing on the 450 MHz–1 GHz (low band), 1 GHz–7 GHz (Mid band), 7 GHz–24 GHz (upper-mid band), and 24 GHz–52 GHz (High band/mmWave) in the recent years regarding the announcement from the international telecommunication union (ITU)<sup>5–8</sup>. In these telecommunication systems, antennas and amplifiers are significant components that are influencing the coverage (radiation performances) and figure of merit (FoM) of RF circuits<sup>9,10</sup>. Transmitting high-power signal in the communication systems (i.e., combinational of active and passive devices) is a challenging task where intelligent methods including proper optimization methods are required<sup>11,12</sup>. Figure 1 presents the design of wireless system that can include important RF designs as: low pass filter (LPF), amplifier (AMP), monolithic microwave integrated circuit (MMIC), and antenna, where various high performance circuits are required to have successful complex system.

In the above mentioned wireless communication systems, amplifiers as low-noise amplifiers (LNAs) with high power amplifiers (HPAs) and antennas play an important role in receiving and transferring large signals. For this case, active device (i.e., amplifiers) and passive component (i.e., antenna) must have very satisfied output performance in the determined band frequency. The design and optimization of these components can face with the problems due to the nonlinear behavior of used transistor models in the amplifiers, quality factor of passive components, environment effects, etc. Hence, strong and multi-objective optimization algorithms are required to help engineers in designing these circuits. In a recently published papers, applying nonlinear optimizations gets the attention of engineers in optimizing RF circuits<sup>13</sup>. In designing these circuits, the more accurate platform for applying the optimization algorithms must be selected considerably. Optimizations as support vector machine (SVM)<sup>14</sup>, Kriging<sup>15</sup>, polynomial-based surrogate modeling<sup>16</sup>, particle swarm optimization<sup>17–19</sup>, and genetic algorithm<sup>20–22</sup> are suitable optimization methods for designing RF designs; however, when the design parameters with circuit designs are lot and complex these methods can not be powerful enough. To tackle this problem, intelligent-based optimization approach can be a powerful one<sup>23–26</sup>.

Artificial neural networks (ANNs) are presented as an accurate modeling network that can model the non-linear circuits in a remarkably successful way<sup>27</sup>. In<sup>28</sup>, the optimization process based on the ANN is applied for designing the active antenna that can be suitable for 5G networks. These methods can help electronic design automation (EDA) tools in improving the modeling problems. The DNN (network includes multi hidden layers) is used in<sup>29</sup> for designing and optimizing a receiver that is suitable for low earth orbit (LEO) satellite communications. The works in<sup>28,29</sup> present optimization methods for designing either antenna or power amplifier by just considering the effect of individual components. However, in the communication systems both the antenna section and HPA device must be optimized concurrently in order to achieve high performance output responses which lack in the recently published works. Another problem that exists in the recent works is the provided computer-aided design (CAD) tools that may not be suitable for concurrent simulations. Hence, a universal and strong optimization environment is required that can be the combination of EDA tool and the numerical analyzer together.

This paper devotes to present such an intelligent-based optimization method for designing and optimizing the communication systems including active and passive devices concurrently which is lacking in the previous studies. It provides an optimization-oriented process for designing and optimizing nonlinear circuits as HPA and antennas that can be employed for 5G/6G networks. In the first phase, the initial structure of active and passive devices are constructed automatically. Afterwards, the configured HPA and antenna are optimized concurrently

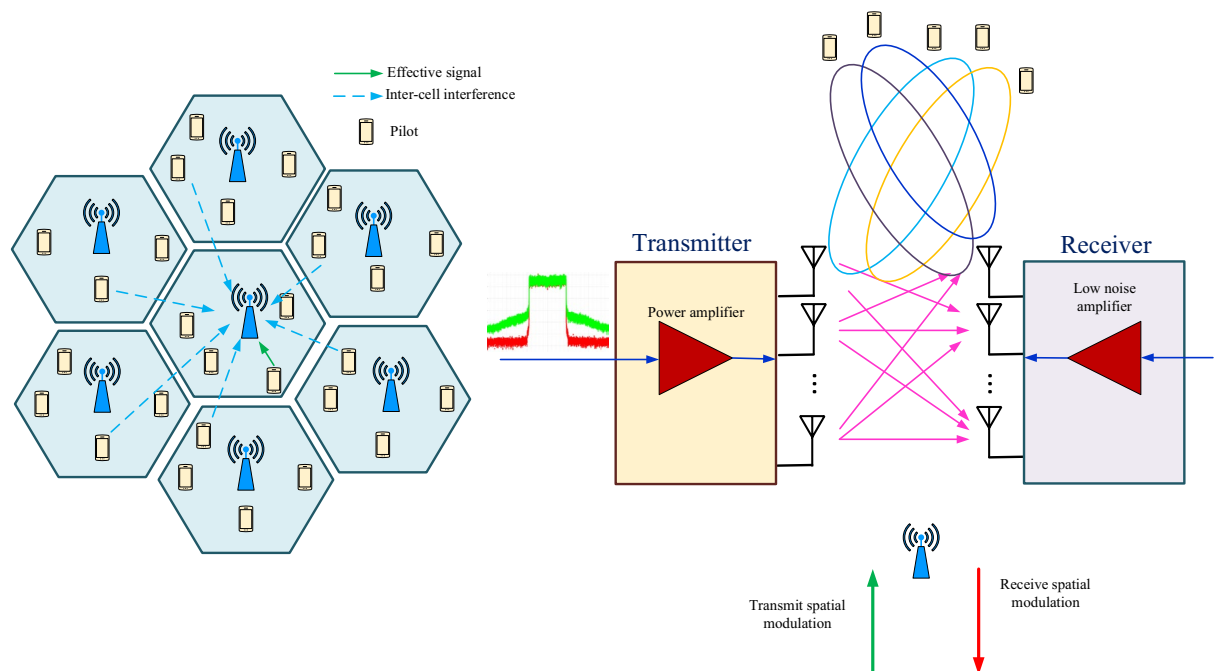

**Figure 1.** Complete multi-technology wireless system design.

in their related design specifications and in a fully automated environment. In particular, the HPA is optimized in terms of power gain, output power, efficiency, and linearity and the antenna is optimized in terms of gain and bandwidth. Typically, optimizing both nonlinear circuits as HPA and antenna is not straightforward and requires additional manual interruptions. Hence, combinational of EDA tools and numerical analyzers provide a strong co-simulation environment. In this work, the whole optimization process is implemented in an automated environment that is the combination of EDA tool and the numerical analyzer: (1) a script for controlling the nonlinear simulation results of HPA and antenna, (2) a mathematical solver for dealing with the generated huge amount of data. After creating an automated environment, the initial structures of devices are generated: here bottom-up optimization (BUO) method is employed<sup>30</sup>. Then it is time for employing the multi-objective optimization methods for optimizing various specifications of configured active and passive devices, concurrently. Recently combination of multi-objective optimizations with deep neural networks (DNNs), (i.e., multi-layer neural networks), have proved their validity in designing and optimizing nonlinear circuits<sup>31</sup>. Hence, employing DNNs with implementation of multi-objective optimization methods are proposed. In this work, the multi-objective multi-verse optimizer (MOMVO)<sup>32</sup> method with long short-term memory (LSTM) DNNs are used due to the effectiveness of function in approximating the Pareto-optimal front (POF) for more than three objectives<sup>32</sup>. Respectively, the LSTM-based DNNs are used for predicting output specifications in a large bandwidth.

The novelty of this work is divided into five subsections: (1) providing a reliable simultaneous co-operation of EDA tools and mathematical analyzer; (2) configuring the initial structure of active and passive devices; (3) constructing and employing multi-objective strong algorithms for optimizing various design specifications; (4) implementing these algorithms to the LSTM-based DNNs for optimizing the model and sizing the nonlinear circuits such as HPA and antenna; (5) optimizing the HPA and antenna concurrently that can be suitable for next generation networks.

The remained part of this manuscript is structured as follows: section “Literature review” presents the literature review and section “Proposed method” describes the proposed method. The detail descriptions with employed steps are provided in section “Detailed descriptions for the employed steps in the proposed optimization method”. Simulation results of the proposed method are provided in section “Practical implementation of proposed method” and finally section “Conclusions” concludes this manuscript.

## Literature review

Over the last decade, ultrafast wireless communication systems are required where these systems must be optimized in terms of power, gain, efficiency, linearity, and so on<sup>33</sup>. However, it is a challenging task to concurrently optimize the FoM of active and passive devices<sup>34–38</sup>. Recently, various studies have been presented and this section devotes to provide the literature review where optimization methods are employed for enhancing the overall performance of system.

In<sup>39</sup>, a joint design methodology for designing antenna and amplifier is presented where a common parametric space is employed for realizing the targeted specifications of the system. In the presented method, intermediate and potentially lossy components are not used leading to achieve optimal impedance interface between active and passive devices. Typically, the big challenging task is to directly matching the the transistor drain output to its optimal load impedance. In<sup>40</sup>, circuit-electromagnetic codesign methodology is applied leading to find the optimal interface impedance between antenna and amplifier. Another solution is provided in<sup>41</sup>, where for each of the channels existed between antenna and amplifier, low pass matching networks are employed. From another point of view, in<sup>42</sup> the optimization algorithm is employed for achieving design parameters of the load modulator circuit leading to improve the its energy-efficiency.

Artificial neural network (ANN) is employed in<sup>28</sup>, for optimizing the radiating part of active antennas in 5G services. For considering and computing the nonlinear characteristics of system, the harmonic neural network (modelled for the antenna) is designed and simulated leading to reduce the consumed-time of electromagnetic (EM)-simulations.

Through the joint optimization design methodology, in<sup>43</sup> this method is employed for designing wideband, and high efficiency active integrated array element that is interfaced with the antenna. In this study, a metal cavity-backed bowtie slot is applied to achieve the optimal interface impedance.

By reviewing the recently published literature on the combination of active and passive devices, it is recognized that concurrently optimizing various specifications such as output power, gain, linearity, noise, and so on is missing. Hence, we propose the following methodology for improving the overall performance of systems in terms of various specifications.

## Proposed method

Concurrently optimizing active and passive components, existed in 5G/6G communication systems, is not straightforward and typically requires the additional efforts by the RF designers. For reducing the designers' interruptions and providing an automated optimization process, artificial intelligent, is selected in accurately modeling responses<sup>44</sup>. This sections devotes to describe and give introduction about the proposed method.

In the 5G/6G communication systems the propagation loss is considerably large, and request high output power generated from the amplifier for guaranteeing the satisfied quality of the signal. Hence, providing the reliable and high-performance amplifiers and antenna as active and passive components play important roles. All the design process is executed in an automated environment where the numerical analyzer is the main core for handling all simulation process. The overall automated environment is depicted in Fig. 2.

After generating the automated environment, we propose two-step automated methodology where firstly the initial structures of HPA and antenna are generated, and afterwards the optimal size of design parameters through LSTM-based DNNs are predicted. Figure 3 presents the general flowchart of the proposed method.

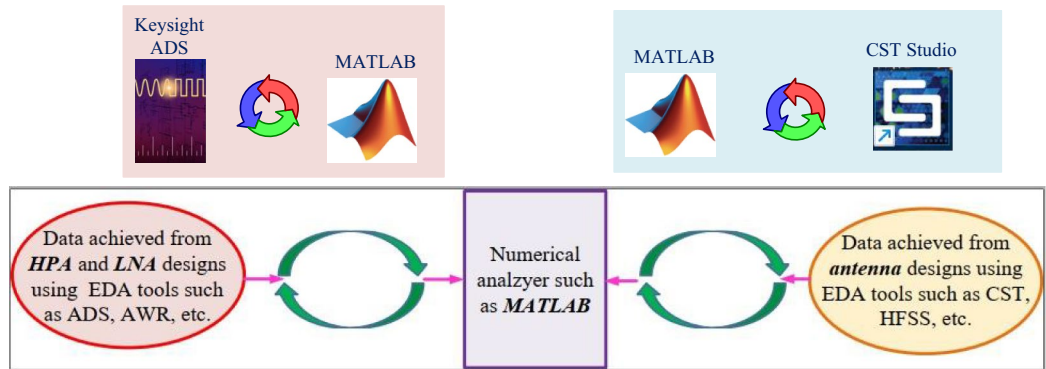

**Figure 2.** Proposed approach for optimizing concurrently the nonlinear circuits where the numerical analyzer is the main core of optimization process.

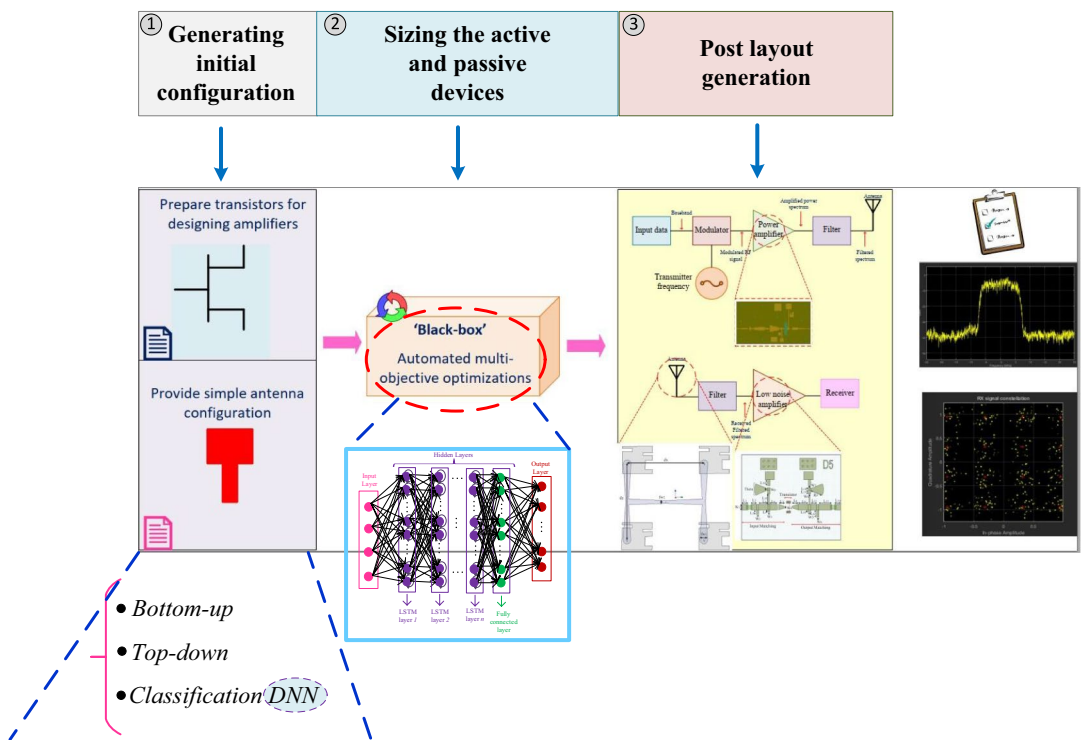

**Figure 3.** General description of the proposed automated optimization process results in ready-to-fabricate layouts.

For the active devices (i.e., amplifier) and passive device (i.e., antenna), the transistor model with transmission lines (TLs) are selected and prepared, respectively. Afterwards the combination of multi-objective optimization with DNN is employed for sizing the various existed parameters in devices, leads to optimize active and passive designs in various specifications. As presented in Fig. 3, the first phase (i.e., generating the initial structure) can include various methods as: bottom-up optimization (BUO)<sup>30</sup>, top-down optimization (TDO)<sup>45</sup>, simplified real-frequency technique (SRFT)<sup>46</sup>, and classification DNN<sup>12</sup> where the suitable method can be selected regarding the overall system specification. At the second phase (i.e., sizing the design parameters), the LSTM-based regression DNN can be employed for achieving the optimal design parameters. Some of the various targeted specifications for the 5G/6G communication systems are presented in Fig. 4. As it is clear, the installed antennas must be able to optimize the radiated signals and nonlinear performances. Hence, advanced modeling and multi-objective optimization algorithms are required for designing and optimizing high performance HPAs, LNAs, and antennas in terms of various specifications.

For providing high performance system, each of the determined circuits must work properly. Hence after designing and optimizing each passive and active device with the proposed method, all these circuits are combined together and the automated optimization is performed for the overall system. The set of data can be varied as the duty of DNN is to predict the output of the new generated data. The proposed optimization method

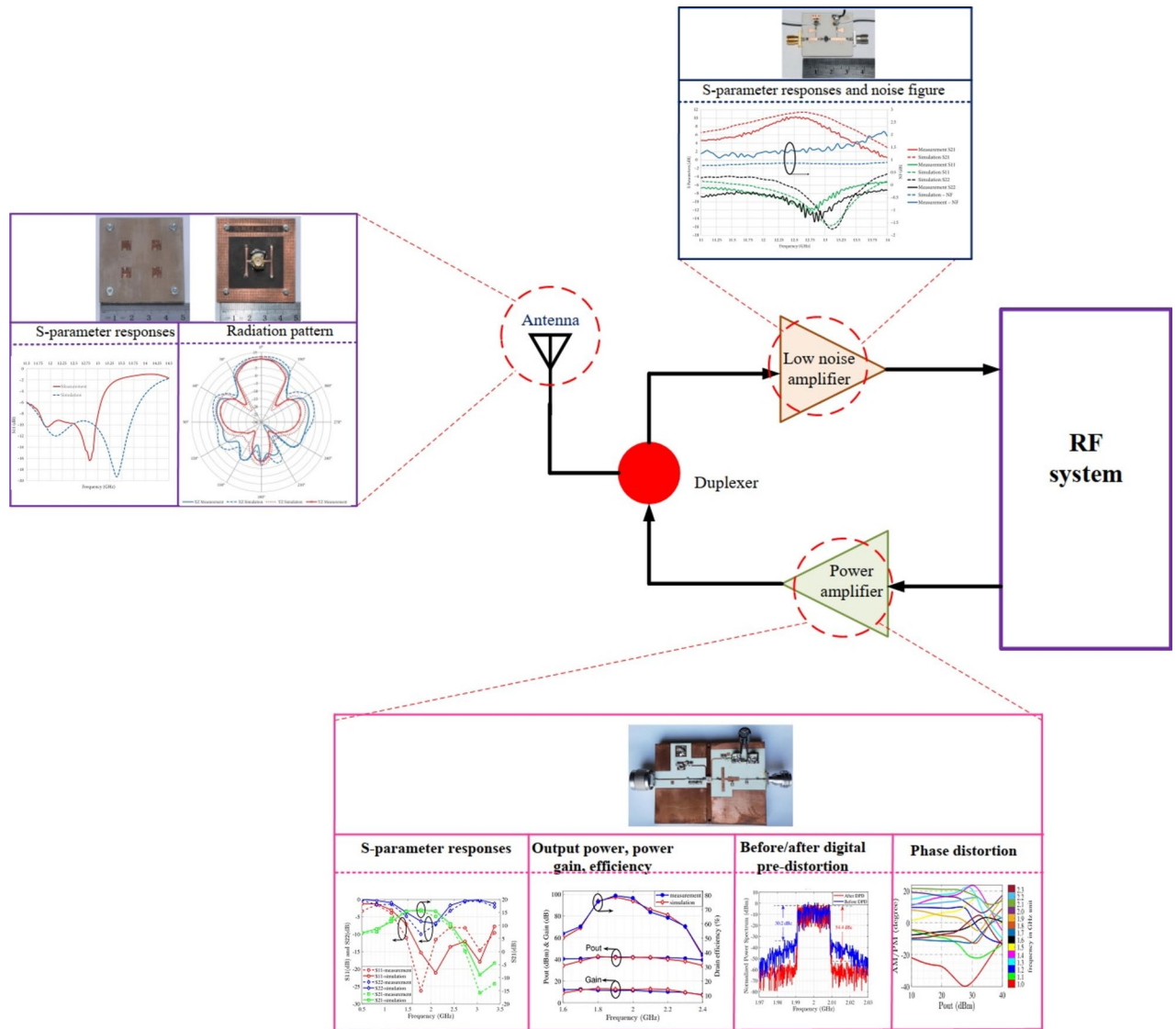

**Figure 4.** Typical blocks of communication systems include HPA, LNA, and antenna designs.

optimizes the whole system in terms of various nonlinear specifications as return loss, power gain, output power, efficiency, linearity, stability, and thermal of HPA, gain and noise figure of LNA, bandwidth, gain and beam direction of antenna, (if any). In the presented method, all the electromagnetic (EM) design rules are implemented which provides ready to fabricate layouts.

The problem is solved by:

- Providing a fully automated optimization environment without any manual interruptions;
- Using multi-layer neural networks (i.e., DNN) for optimizing determined various nonlinear specifications as return loss, power gain, output power, efficiency, linearity, stability, and thermal, gain and noise figure specifications, bandwidth, gain and beam direction, (if any) concurrently;
- Applying multi-objective optimizations to be employed in the DNNs;
- Employing the fabrication rules and constraints inside the optimization process that results in passing EM simulations and prepares ready-to-fabricate layouts. In simple words, it must be clarified as follows: The layout of each circuit in order to be sent for fabrication in any companies, needs passing the existed EM simulations in the EDA tools. The EM simulations do not give acceptance proof when we as designers do not pay attention to some existed rules and constraints in circuits. For example: if the ratio between length and width of components is less or more than the defined design rules, the EM simulation does not give us acceptance news. Therefore inside the optimization coding, the design rules that are determined for each component must be implemented for having acceptance proof from EM simulations;
- Concurrently optimizing various nonlinear circuits which results in optimizing various and many design specifications once together.

## Detailed descriptions for the employed steps in the proposed optimization method

In the presented method, concurrently amplifier and antenna designs are optimized together. For each design, the suitable optimization process is provided and then these devices are combined together. The general description of the proposed method is as follows:

### Step 1: Providing an automated environment that is the combination of EDA tools and the numerical analyzer

This step is to just create an automated environment and the optimization process is not stated yet. Firstly, a co-simulation environment between EDA tools and numerical analyzer is created for achieving the related simulation results of the nonlinear designs and also for mathematically dealing with the huge amount of data that are generated by EDA tools<sup>47,48</sup>. Figure 2 presents the general overview of the co-simulation environment for start optimizing both active and passive devices concurrently. The numerical analyzer is the main core of the process that handles the generated huge amount of data from both amplifier and antenna designs.

In this co-simulation environment, the EDA tools are working in the background and the numerical analyzer is handling the optimization process by the generated data from the EDA tools. Hence, all the optimization process is performed automatically without any interruption of humans. In simple words, EDA tools are used as an environment for: (1) designing amplifiers and antenna circuits; (2) generating design specifications as return loss, power gain, output power, efficiency, linearity, stability, and thermal of amplifier, gain and noise figure of LNA, bandwidth, gain and beam direction of antenna, (if any). One can note, that while designing any circuit, in the EDA tools these specifications can be achieved as they are the output results of any circuit. From beside, the numerical analyzer is collecting the generated large amount of data from EDA tools and settling the platform for performing multi-objective optimizations through the DNNs.

In summary, a multi-surface combination of EDA tools and numerical analyzers for designing and optimizing amplifiers and antennas is generated. The optimization is employed in a multi-surface environment as amplifiers (i.e., HPAs and LNAs) are designed in the ADS, AWR, etc. simulation tools and antennas are designed and simulated in HFSS, CST, etc. Hence, the simulation environments of determined circuits are different and there is not one common tool for simulating all circuits. In addition, it must be noted that one numerical analyzer such as MATLAB, Python, etc. is used as a connection tool between ADS/ AWR and CST/HFSS softwares (see Fig. 2).

### Step 2: Designing the initial configuration of amplifier and antenna

After constructing the automated environment where EDA tools and numerical analyzer is working together, it is time to construct the initial configuration/ topology/ geometry of both the active and passive devices, i.e., HPA/LNA and antenna, respectively. The initial configuration of active and passive devices are generated using various optimizations as presented in section “Proposed method”: BUO, TDO, SRFT, and/or classification DNN.

### Step 3: Applying multi-objective optimization algorithms

Mathematically, the optimization term refers to methods for finding the optimal solutions of functions in diverse conditions. For either single or multiple functions, various variables can be determined by arranging the set of constrains. In any system design the initial guess for the variables is executed, and then with respect to the interrelationships between various specifications, the optimal parameters are achieved. In single objective functions, only one single objective function is optimized. In contrast, multi-objective optimization is executed for optimizing two or more that two objective functions.

Typically in multi-objective optimization, the POF is the set of all Pareto efficient possibilities. Hence, employing POF set is presented in this work and the general definition is illustrated in Eq. (1). Figure 5 shows the concept of POF for any two functions as  $f_1$  and  $f_2$ .

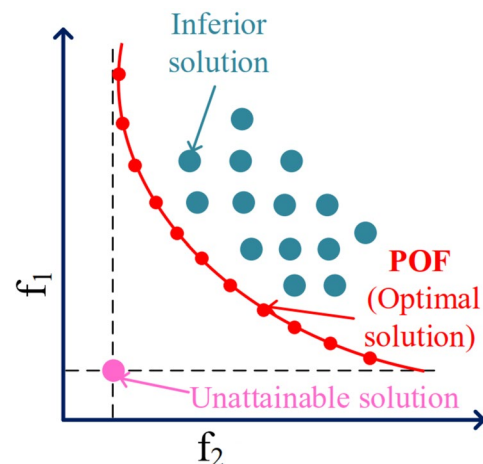

**Figure 5.** POF presentation for multi-objective functions as  $f_1$  and  $f_2$ .

$$\text{minimize}_{x \in \chi \subseteq \mathbb{R}^d} G(x) = [g_1(x), g_2(x), \dots, g_m(x)] \quad (1)$$

where  $\chi$  is the design space,  $x$  is the decision vector and  $G$  is a vector of  $m$  objective functions ( $g_i(x)$ ).

In the presented method an oriented optimization process is constructed to optimize active and passive devices concurrently in terms of many specifications, presented in section “Proposed method”, for determined various designs. Some of the various multi-objective functions can be: multi-objective particle swarm optimization (PSO)<sup>49</sup>, multi-objective pareto front using modified quicksort (PFUMQ)<sup>50</sup>, Thompson Sampling Efficient Multiobjective Optimization (TSEMO) algorithm<sup>51</sup>, MOMVO method, and so on. These multi-objective optimization methods lead to optimize various nonlinear design specifications.

#### Step 4: Training and constructing DNNs with the multi-objective optimization algorithms

Implementation of multi-objective algorithms requires a reliable platform. Surrogate modeling (i.e., modeling with artificial neural networks) is a reliable method for employing the multi-objective methods where artificial intelligence is one type of the surrogate modeling and includes deep learning. The use of DNN has recently become popular due to its merit in the accurate modeling. The regression LSTM-based DNNs are used for modeling the nonlinear circuits as amplifiers and antennas. As Step-2 presents, the initial configuration of active and passive devices are constructed. Then in the constructed automated environment, the design parameters such as: width ( $W$ ) and length ( $l$ ) of design elements, inductors, capacitors, TL sizes, etc. are altered using Latin hypercube sampling technique within the specific range<sup>52</sup>. Hence, large amount of data that will be divided into training, validation, and testing data are achieved automatically as all the process is performed in an automated environment. This data are used for modeling the nonlinear circuits with DNNs.

Figure 6 presents the general structure of the LSTM-based DNN: it consists of the input layer, hidden layer, and output layer. The input layer presents the set of variables from the active and passive devices and the output layer presents the output specifications of designs. Since it is targeted to achieve the ready-to-fabricate layouts, for passing the EM simulations successfully the constraints presented in<sup>53</sup> must be employed where TLs are used. For any of the passive devices, included inductors and capacitors, the constraints during the optimization can be provided by designers due to the availability of components in the process design kit (PDK).

The hyperparameter of hidden layers can be achieved through Bayesian optimization, rule of thumb, Thompson sampling (TS) algorithm, and so on<sup>31,31</sup>. For optimizing the passive and active devices, the suitable DNNs are trained as presented in Fig. 6. With respect to the prepared data, the DNN is trained using Eq. (2) where  $X_{\text{Train}}$  is the sampling data and  $Y_{\text{Train}}$  corresponds to the output responses of trained input data. The accuracy of the trained DNN is calculated by considering the difference between  $Y_{\text{Test}}$  (i.e., data generated through testing data) and  $Y_{\text{Pred}}$ , that is achieved through Eq. (3).

$$\text{net} = \text{trainNetwork}(X_{\text{Train}}, Y_{\text{Train}}, \text{layers}, \text{options}) \quad (2)$$

$$Y_{\text{Pred}} = \text{predict}(\text{net}, X_{\text{Test}}) \quad (3)$$

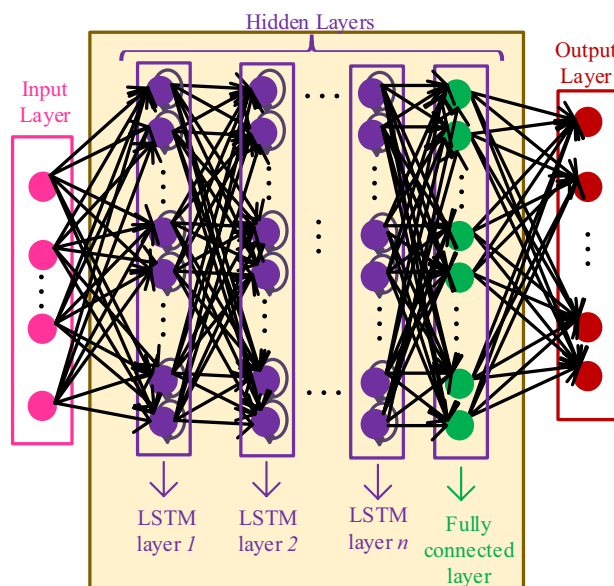

**Figure 6.** The general structure of DNN.

**Step 5: Combination of active and passive designs for generating the high performance 5G/6G communication system**

After modeling and constructing the related DNNs for active devices (i.e., amplifiers) and passive devices (i.e., antennas), these devices are located in their own position in the receiver and transmitter sides. By simulating all these devices together, the simulation results can be altered somehow due to the existence of nonlinear components such as transistors. Hence, some pruning iterative optimization (i.e., increasing/decreasing the values of parameters) can be required. The proposed optimization method can itself do this iteration optimization and finally provide a 5G/6G communication system that have optimal and desired output performance. As presented in the previous section, numerical analyzer as MATLAB can handle this iteration process for both active and passive devices. The final generated outcomes are the ones that any designer would wish to achieve.

## Practical implementation of proposed method

In this paper, transceiver section of any communication system is designed and optimized where for the design of HPA and antenna, ADS and CST softwares are used, respectively. The general flowchart of the proposed method is presented in Fig. 7. The overall optimization process is performed on the CPU execution environment, with detailed information as Intel Core i7-4790 CPU @ 3.60 GHz with 64.0 GB RAM. In this platform, the total computational time for performing the proposed methodology is around 12 h and 35 min.

The HPA and antenna designs are configured through the BUO method, in this work. Figure 11 presents the general overview of the BUO method for generating the initial structure of the HPA where the optimization is started by one inductor-capacitor (LC) ladder and then increasing in the number of LC ladders, sequentially<sup>30,54</sup>. The employed transistor model is WIN 0.25  $\mu\text{m}$  GaN process and it is biased as 28 V and 100 mA/mm. For the antenna designs based on the BUO method, the initial structure is started with one TL and then increased in the number of TLs<sup>55</sup> (see Fig. 12)<sup>54</sup>.

After generating the initial structures for both HPA and antenna, the multi-objective optimization as MOMVO method is employed for constructing objective functions as PoF representations for the HPA design. In this work, the objective functions are power gain ( $G_p$ ), and power added efficiency (PAE) specifications of HPA. As Fig 9 presents the MOMVO method is employed in the output layer of LSTM-based DNN for improving the performance of HPA. The multi-objective optimization is employed for  $G_p$  and PAE functions presented over the frequency band with the target of maximizing the PO of  $(G_p)^{2-\alpha} \times (PAE)^{2(1-\alpha)}$  function where  $\alpha$  takes values between 0 and 1 values.

Respectively, Fig. 8 shows the general structure of LSTM-based DNN for predicting the optimal impedances leading to match the HPA and antenna designs in the transceiver section of 5G/6G communication systems.

For constructing these two DNNs, suitable amount of data is required. For this case, the design parameters of configured HPA (i.e., values of inductors and capacitors) and antenna (i.e., width and length of TLs) are iterated randomly and with respect to each variable, the related output specification is gathered<sup>56</sup>. The design parameters of each active and passive devices are iterated within the range of  $[\pm 5\% - \mp 50\%]$  with step size of 5%. In generation of DNNs, 5000 data with multi-segment output responses are generated. The hyperparameters of DNNs, includes number of neurons and hidden layer, are achieved through the bayesian optimization<sup>57</sup>. For the HPA design, 4 hidden layers with 200 neurons and for the antenna design, 5 hidden layers with 150 neurons are estimated. Figure 13 presents the normalized root mean square error (RMSE) performance for the trained HPA where it demonstrates that in 200th neuron it achieves 0.073 accuracy. Additionally, the loss result of trained HAP over

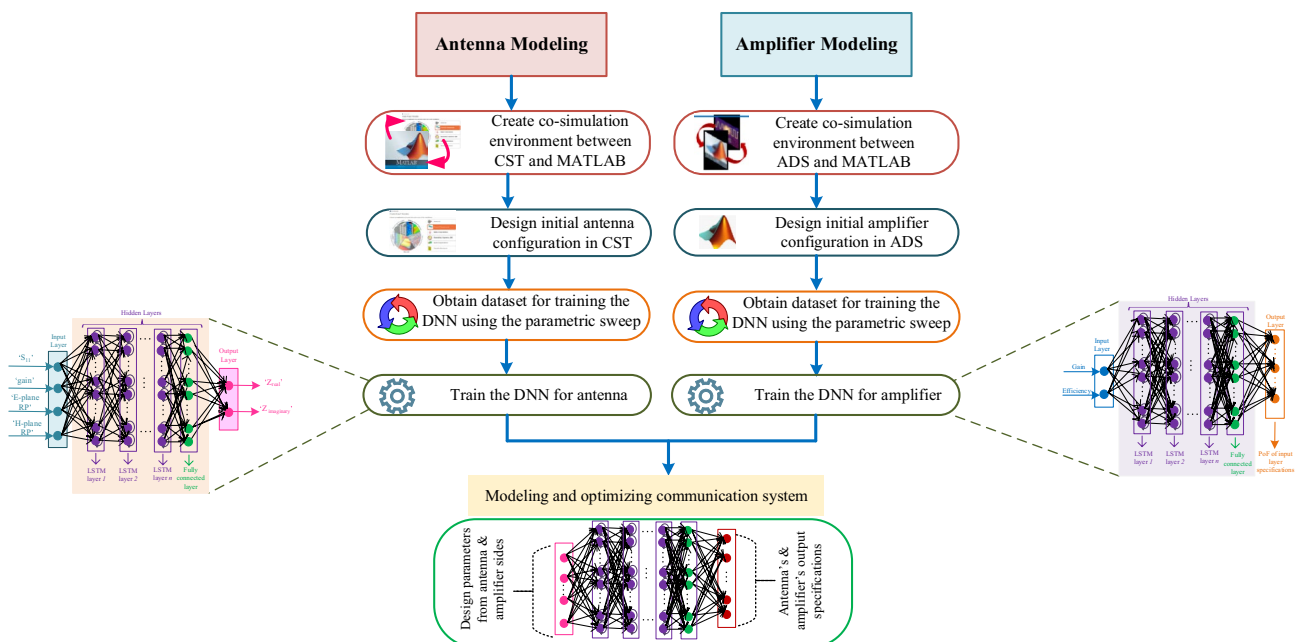

**Figure 7.** Flowchart for designing and optimizing the transceiver section of any communication system.

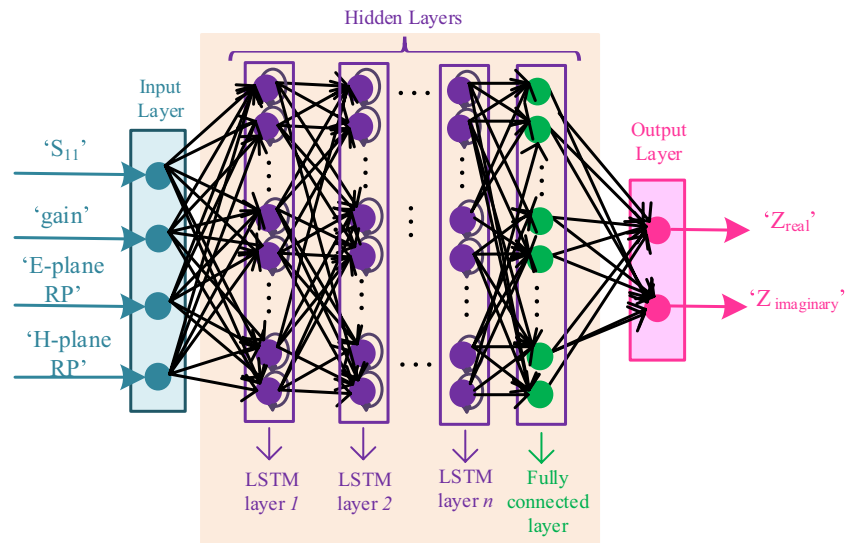

**Figure 8.** Modelled antenna with LSTM-based DNN.

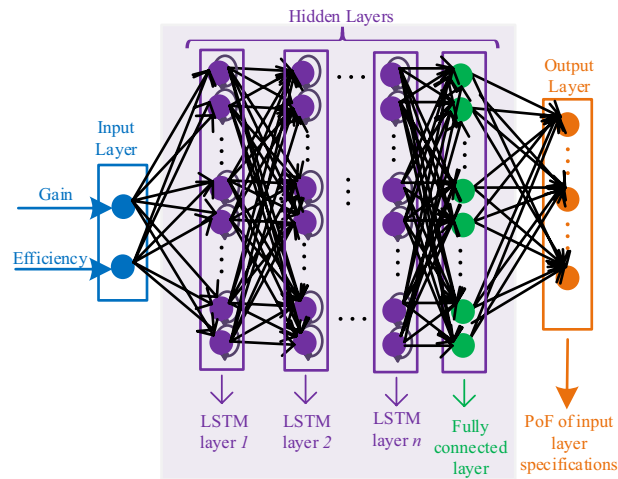

**Figure 9.** Modelled amplifier with LSTM-based DNN.

the iteration is presented in Fig. 14. The proper DNN is constructed for the antenna as well that achieves 0.081 normalized RMSE specification in 150th neuron. For both of the DNNs, learning rate, dropout rate, and batch size are 0.005, 0.5, and 1, respectively.

Figure 10a shows HPA configuration with the design parameters achieved from the BUO method. Figure 10b presents the initial configuration with design parameters obtained from BUO method. After employing the proposed LSTM-based DNNs for both initial active and passive devices separately, these circuits are optimizing together leading into better and satisfied performance. Figure 10.c presents the overall transceiver system design that have passed the EM simulation; hence they can be fabricated easily. The proposed method can generate the ready-to-fabricate layouts where the industry companies can fabricate these layouts easily.

Figure 15a also presents the bandwidth of the optimized antenna with the various generated impedance from the antenna side leading to optimize the HPA with respect to these data (see Fig. 15b). The related various output results of the HPA design before and after optimization are shown in Fig. 16. These figures demonstrate that the output responses after the optimization is much more better than the results before the optimization. Lastly for proving the linearity performance of the proposed method, DPD performance is provided in Fig. 17.

Table 1 summarizes the various presented optimization processes in the recently published literature. By comparing our methodology it can be observed that: concurrently optimizing active and passive devices through the DNNs and multi-objective methods is presented for the very first time leading results in enhancing the overall performance of communication systems.

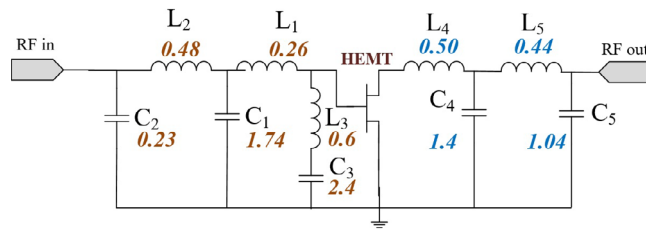

a)

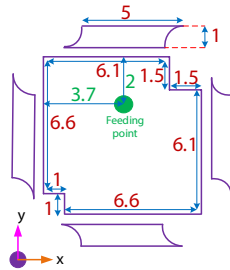

b)

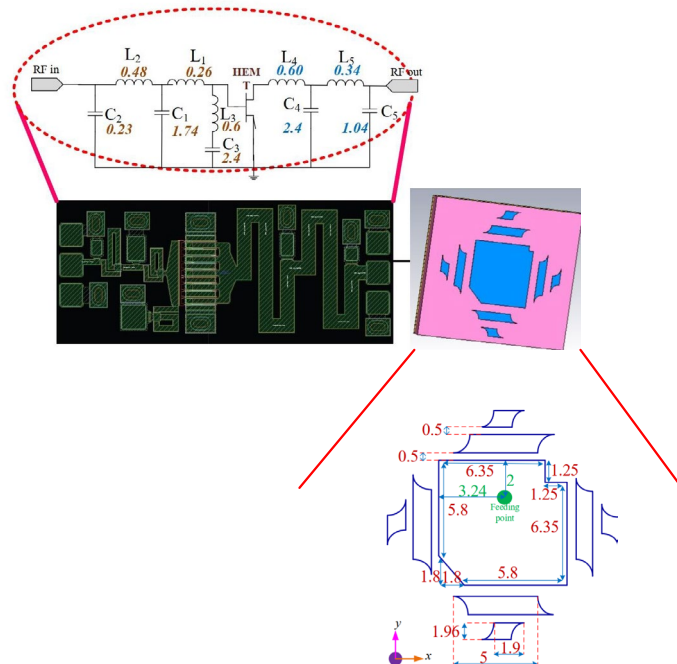

c)

**Figure 10.** (a) HPA design using BUO method, (b) antenna design using the BUO method, (c) optimized antenna with optimized HPA through proposed method.

### Conclusions

This work is based on presenting the all-inclusive style that (1) reduces the manual breaks, aka time-to-market, and (2) delivers ready-to-fabricate layouts of the device that exhibits global optimum performances. An automated optimization process for comprehensive design of high-performance amplifiers with antennas through LSTM-based DNNs is proposed. Firstly, an automated environment with the combination of EDA tools and

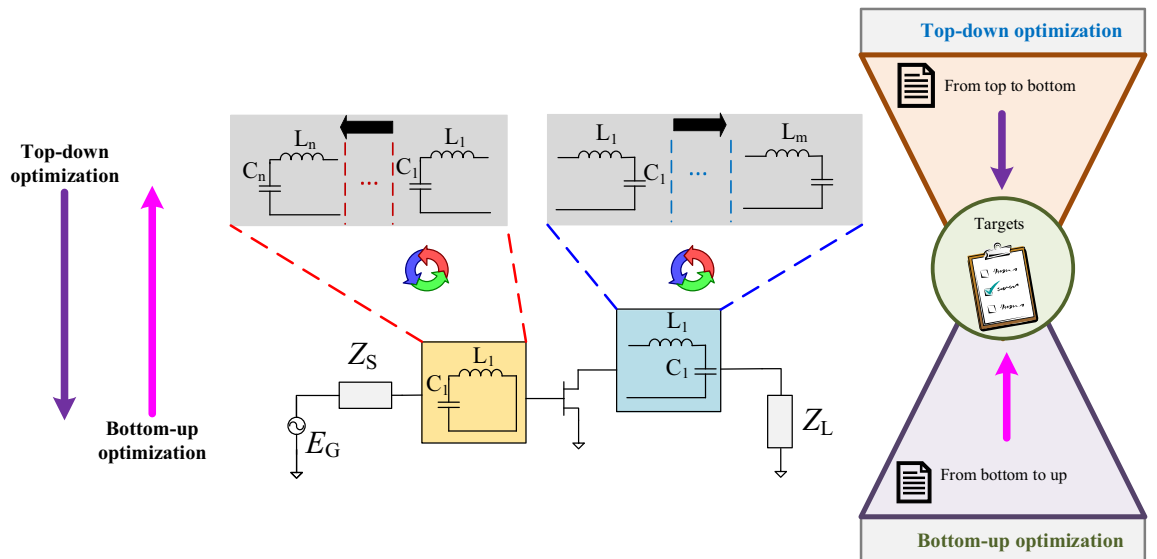

**Figure 11.** Illustration of BUO and TDO methods in configuring the initial structures of the amplifiers.

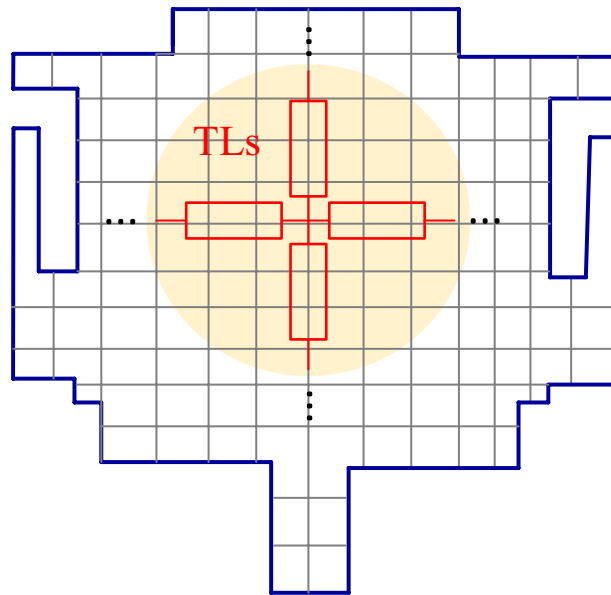

**Figure 12.** Implementation of BUO method in designing a single antenna.

numerical analyzer is provided. Then, the initial structures of active and passive devices are configured through BUO method and afterwards the DNNs are employed for achieving the optimal design parameters. In the presented method, all the EM design rules are implemented which results in reducing simulation time in the harmonic balance simulation environment and provides ready to fabricate layout.

The output of this study can be summarized as follows:

- Generating the initial configurations of active and passive devices;
- Reducing the human interruptions and minimizing some created technical errors by designers;
- Reducing the time consuming EM simulation due to the implemented fabrication constraints;
- Generating ready-to-fabricate layout of RF integrated design which lighten the application in the industry.

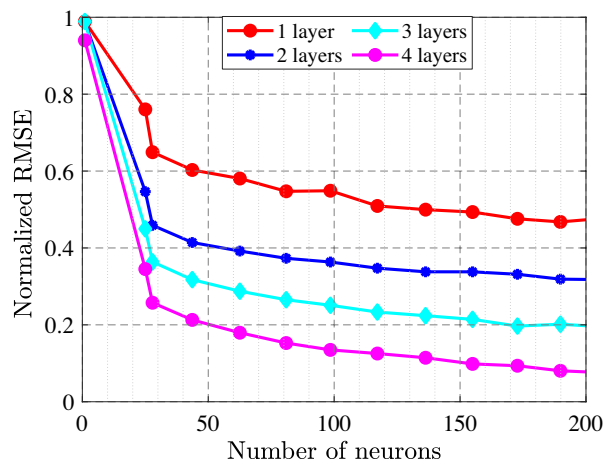

Figure 13. Normalized RMSE performance for the trained HPA in terms of number of neurons.

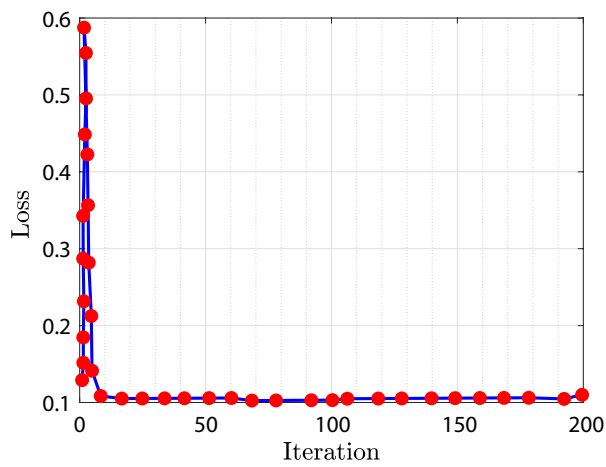
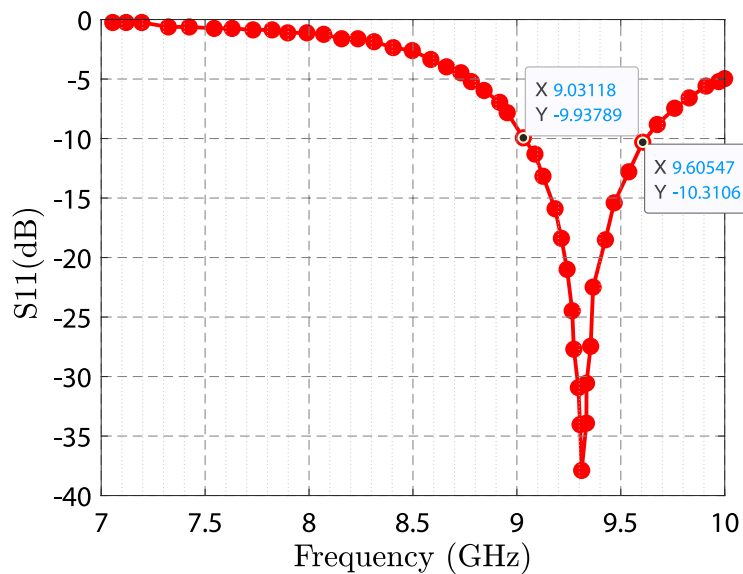
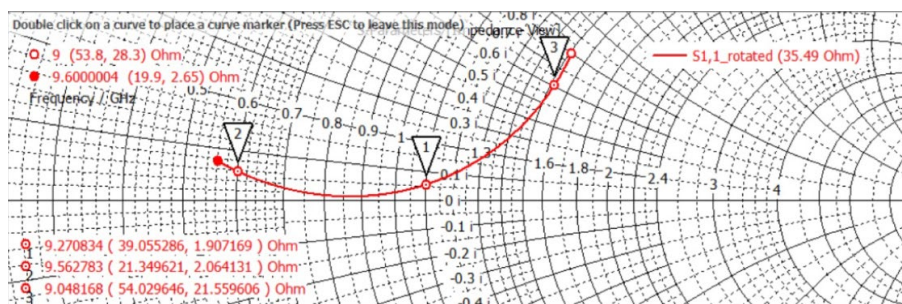

Figure 14. Loss performance of trained HPA over the iteration.



a)



b)

**Figure 15.** Antenna specification; (a) bandwidth of antenna, (b) generated impedance from antenna side.

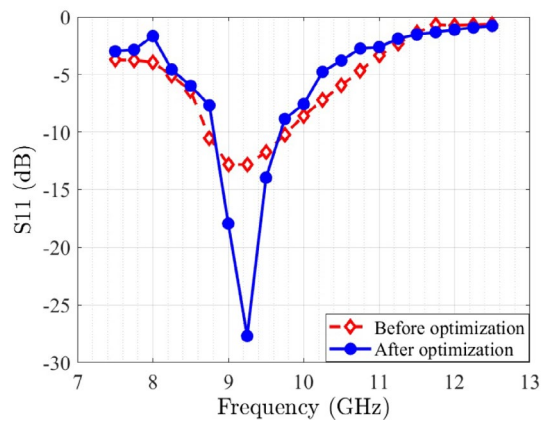

a)

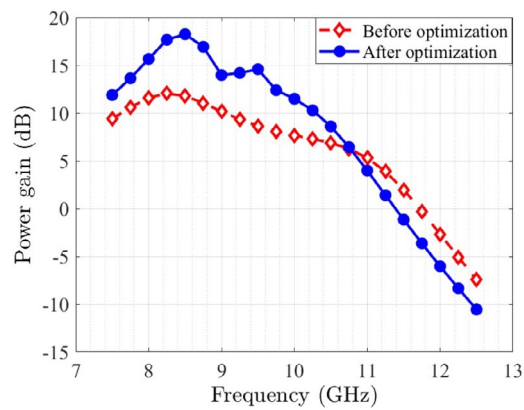

b)

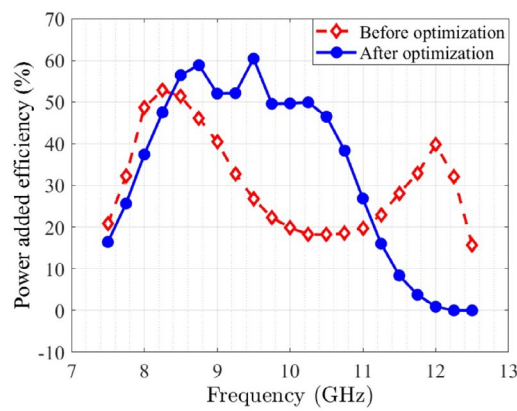

c)

**Figure 16.** Overall performance with the existence of antenna and amplifier before and after optimization; (a)  $S_{11}$ , (b) gain, (c) efficiency.

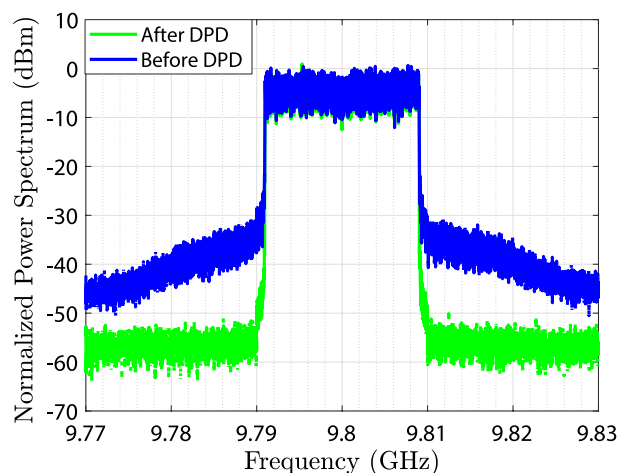

**Figure 17.** Output spectrum presentation with 20 MHz LTE signal: before and after DPD.

Refs.	Design	Method	Contribution
39	Compact Doherty power amplifier with antenna	Codesign and joint optimization	Power efficiency Bandwidth
40	K-band antenna with GaN amplifier	Codesign method	Gain Radiation characteristics
58	Phase-tunable amplifier-antenna array system	Non-linear optimizer in MATLAB	Effective isotropic radiated power
42	64-QAM I/Q modulator that is based on load modulation	Genetic algorithm	$S_{21}$ parameter
28	Millimeter-wave active antenna	Harmonic balance optimization loop with neural network	Bandwidth Polarization
59	Optimal matching networks used in mm-wave applications	Joint optimization based on the load-pull simulation	Efficiency Bandwidths
43	Active integrated array element with antenna-power amplifier interface	Joint optimization based on the parametric sweep	Power efficiency Effective isotropic radiated power
60	Scalable planar 2-D active array antenna configuration	Optimization located in the EDA tools	Gain Overall size
26	Wireless power transfer system	Machine learning approach	Power supply
This work	Active and passive devices concurrently	Deep neural networks with multi-objective optimizations	Bandwidth Power gain PAE Linearity

**Table 1.** Summary of various methodologies and the optimization goals presented recently for communication systems.

### Data availability

The datasets used and/or analysed during the current study are available from the corresponding author on reasonable request.

Received: 7 February 2024; Accepted: 18 July 2024

Published online: 03 August 2024

### References

- Kouhalvandi, L., Ceylan, O. & Ozoguz, S. Multi-objective efficiency and phase distortion optimizations for automated design of power amplifiers through deep neural networks. In *2021 IEEE MTT-S International Microwave Symposium (IMS)* 233–236. <https://doi.org/10.1109/IMS19712.2021.9574937> (2021).
- Chen, J., Li, S., Xing, J., Wang, J. & Fu, S. Multiple nodes access of wireless beam modulation for 6g-enabled internet of things. *IEEE Internet Things J.* **8**, 15191–15204. <https://doi.org/10.1109/JIOT.2020.3045084> (2021).
- Basar, E. Reconfigurable intelligent surface-based index modulation: A new beyond mimo paradigm for 6g. *IEEE Trans. Commun.* **68**, 3187–3196. <https://doi.org/10.1109/TCOMM.2020.2971486> (2020).
- Alsabah, M. *et al.* 6g wireless communications networks: A comprehensive survey. *IEEE Access* **9**, 148191–148243. <https://doi.org/10.1109/ACCESS.2021.3124812> (2021).
- ITU-T: Setting the standard (2024, accessed 6 Feb 2024). <https://www.itu.int/en/mediacentre/backgrounders/Pages/itu-t-setting-the-standard.aspx>.

6. Lee, K., Kim, J., Jin, E. W. & Kim, K. S. Extreme massive mimo for upper-mid band 6g communications. In *2022 13th International Conference on Information and Communication Technology Convergence (ICTC)* 997–999. <https://doi.org/10.1109/ICTC55196.2022.9952850> (2022).
7. Cui, Z., Zhang, P. & Pollin, S. 6g wireless communications in 7–24 ghz band: Opportunities, techniques, and challenges (2024). [arXiv:2310.06425](https://arxiv.org/abs/2310.06425).
8. 6G mid-band spectrum technology explained (2024, accessed 6 Jun 2024). <https://www.nokia.com/about-us/newsroom/articles/6g-mid-band-spectrum-technology-explained/>.
9. Ali, S. M. A. & Hasan, S. M. R. A 38-ghz millimeter-wave double-stacked HBT Class-F-1 high-gain power amplifier in 130-nm SiGe-BiCMOS. *IEEE Trans. Microw. Theory Tech.* **68**, 3039–3044. <https://doi.org/10.1109/TMTT.2020.2988874> (2020).
10. Zhang, P., Yang, B., Yi, C., Wang, H. & You, X. Measurement-based 5g millimeter-wave propagation characterization in vegetated suburban macrocell environments. *IEEE Trans. Antennas Propag.* **68**, 5556–5567. <https://doi.org/10.1109/TAP.2020.2975365> (2020).
11. Mir, F., Kouhalvandi, L. & Matekovits, L. Deep neural learning based optimization for automated high performance antenna designs. *Sci. Rep.* **12**, 16801. <https://doi.org/10.1038/s41598-022-20941-x> (2022).
12. Kouhalvandi, L., Ceylan, O. & Ozoguz, S. Automated deep neural learning-based optimization for high performance high power amplifier designs. *IEEE Trans. Circ. Syst. I Regul. Pap.* **67**, 4420–4433. <https://doi.org/10.1109/TCSI.2020.3008947> (2020).
13. Kutinlahti, V.-P., Lehtovuori, A. & Viikari, V. Optimizing rf efficiency of a vector-modulator-driven antenna array. *IEEE Antennas Wirel. Propag. Lett.* **19**, 2507–2511. <https://doi.org/10.1109/LAWP.2020.3037755> (2020).
14. Angiulli, G., Cacciola, M. & Versaci, M. Microwave devices and antennas modelling by support vector regression machines. *IEEE Trans. Magn.* **43**, 1589–1592. <https://doi.org/10.1109/TMAG.2007.892480> (2007).
15. Koziel, S., Couckuyt, I. & Dhaene, T. Robust variable-fidelity optimization of microwave filters using co-kriging and trust regions. <https://doi.org/10.1002/mop.27447> (2013).
16. Chávez-Hurtado, J. L. & Rayas-Sánchez, J. E. Polynomial-based surrogate modeling of rf and microwave circuits in frequency domain exploiting the multinomial theorem. *IEEE Trans. Microw. Theory Tech.* **64**, 4371–4381. <https://doi.org/10.1109/TMTT.2016.2623902> (2016).
17. Wan, J., Xu, C., Qiao, Y. & Zhang, X. Error constraint enhanced particle filter using quantum particle swarm optimization. *IEEE Sens. J.* **21**, 24431–24439. <https://doi.org/10.1109/JSEN.2021.3113364> (2021).
18. Tehsin, S. *et al.* Self-organizing hierarchical particle swarm optimization of correlation filters for object recognition. *IEEE Access* **5**, 24495–24502. <https://doi.org/10.1109/ACCESS.2017.2762354> (2017).
19. Bi, L., Cao, W., Hu, W. & Wu, M. Intelligent tuning of microwave cavity filters using granular multi-swarm particle swarm optimization. *IEEE Trans. Industr. Electron.* **68**, 12901–12911. <https://doi.org/10.1109/TIE.2020.3040658> (2021).
20. Choi, K. *et al.* Hybrid algorithm combining genetic algorithm with evolution strategy for antenna design. *IEEE Trans. Magn.* **52**, 1–4. <https://doi.org/10.1109/TMAG.2015.2486043> (2016).
21. Madapatha, C. *et al.* On topology optimization and routing in integrated access and backhaul networks: A genetic algorithm-based approach. *IEEE Open J. Commun. Soc.* **2**, 2273–2291. <https://doi.org/10.1109/OJCOMS.2021.3114669> (2021).
22. Sasatani, T., Narusue, Y. & Kawahara, Y. Genetic algorithm-based receiving resonator array design for wireless power transfer. *IEEE Access* **8**, 222385–222396. <https://doi.org/10.1109/ACCESS.2020.3044224> (2020).
23. Alavi, R. R. & Mirzavand, R. Range extension in partial spherical near-field measurement using machine learning algorithm. *IEEE Antennas Wirel. Propag. Lett.* **19**, 2003–2007. <https://doi.org/10.1109/LAWP.2020.3025724> (2020).
24. Qian, G., Li, Z., He, C., Li, X. & Ding, X. Power allocation schemes based on deep learning for distributed antenna systems. *IEEE Access* **8**, 31245–31253. <https://doi.org/10.1109/ACCESS.2020.2973253> (2020).
25. Wu, Q., Chen, W., Yu, C., Wang, H. & Hong, W. Multilayer machine learning-assisted optimization-based robust design and its applications to antennas and array. *IEEE Trans. Antennas Propag.* **69**, 6052–6057. <https://doi.org/10.1109/TAP.2021.3069491> (2021).
26. Clerckx, B., Huang, K., Varshney, L. R., Ulukus, S. & Alouini, M.-S. Wireless power transfer for future networks: Signal processing, machine learning, computing, and sensing. *IEEE J. Sel. Top. Signal Process.* **15**, 1060–1094. <https://doi.org/10.1109/JSTSP.2021.3098478> (2021).
27. Mir, F., Kouhalvandi, L., Matekovits, L. & Gunes, E. O. Automated optimization for broadband flat-gain antenna designs with artificial neural network. *IET Microwaves Antennas Propag.* **15**, 1537–1544. <https://doi.org/10.1049/mia2.12137> (2021).
28. Aliakbari, H. *et al.* Far-field-based nonlinear optimization of millimeter-wave active antenna for 5g services. *IEEE Trans. Microw. Theory Tech.* **67**, 2985–2997. <https://doi.org/10.1109/TMTT.2019.2909898> (2019).
29. Zhang, Y. *et al.* Deep neural network-based receiver for next-generation leo satellite communications. *IEEE Access* **8**, 222109–222116. <https://doi.org/10.1109/ACCESS.2020.3044321> (2020).
30. Kouhalvandi, L., Ceylan, O. & Ozoguz, S. Automated matching network modeling and optimization for power amplifier designs. In *2019 11th International Conference on Electrical and Electronics Engineering (ELECO)* 510–513. <https://doi.org/10.23919/ELECO47770.2019.8990407> (2019).
31. Kouhalvandi, L. & Matekovits, L. Hyperparameter optimization of long short-term memory-based forecasting dnn for antenna modeling through stochastic methods. *IEEE Antennas Wirel. Propag. Lett.* **21**, 725–729. <https://doi.org/10.1109/LAWP.2022.3144046> (2022).
32. Mirjalili, S., Jangir, P., Mirjalili, S. Z., Saremi, S. & Trivedi, I. N. Optimization of problems with multiple objectives using the multi-verse optimization algorithm. *Knowl.-Based Syst.* **134**, 50–71. <https://doi.org/10.1016/j.knsys.2017.07.018> (2017).
33. Shen, K. *et al.* Optimizing the focusing performance of non-ideal cell-free mmimo using genetic algorithm for indoor scenario. *IEEE Trans. Wireless Commun.* **21**, 8832–8845. <https://doi.org/10.1109/TWC.2022.3170433> (2022).
34. Domouchtsidis, S., Tsinos, C. G., Chatzinotas, S. & Ottersten, B. Constant envelope mimo-ofdm precoding for low complexity large-scale antenna array systems. *IEEE Trans. Wireless Commun.* **19**, 7973–7985. <https://doi.org/10.1109/TWC.2020.3018431> (2020).
35. Moon, S.-R., Sung, M., Lee, J. K. & Cho, S.-H. Cost-effective photonics-based thz wireless transmission using pam-n signals in the 0.3 thz band. *J. Lightwave Technol.* **39**, 357–362. <https://doi.org/10.1109/JLT.2020.3032613> (2021).
36. Nasir, A. A., Tuan, H. D., Dutkiewicz, E. & Hanzo, L. Finite-resolution digital beamforming for multi-user millimeter-wave networks. *IEEE Trans. Veh. Technol.* **71**, 9647–9662. <https://doi.org/10.1109/TVT.2022.3180786> (2022).
37. Tsinos, C. G., Arora, A., Chatzinotas, S. & Ottersten, B. Joint transmit waveform and receive filter design for dual-function radar-communication systems. *IEEE J. Sel. Top. Signal Process.* **15**, 1378–1392. <https://doi.org/10.1109/JSTSP.2021.3112295> (2021).
38. Yang, J., Aubry, A., De Maio, A., Yu, X. & Cui, G. Multi-spectrally constrained transceiver design against signal-dependent interference. *IEEE Trans. Signal Process.* **70**, 1320–1332. <https://doi.org/10.1109/TSP.2022.3144953> (2022).
39. Iupikov, O. A. *et al.* A cavity-backed patch antenna with distributed multi-port feeding, enabling efficient integration with doherty power amplifier and band-pass filter. *IEEE Trans. Antennas Propag.* **69**, 4412–4422. <https://doi.org/10.1109/TAP.2020.3048529> (2021).
40. Liao, W.-C. *et al.* A directly matched pa-integrated k-band antenna for efficient mm-wave high-power generation. *IEEE Antennas Wirel. Propag. Lett.* **18**, 2389–2393. <https://doi.org/10.1109/LAWP.2019.2937235> (2019).
41. Findelee, C. Array noise matching via the scattering matrix. *IEEE Trans. Antennas Propag.* **67**, 2344–2353. <https://doi.org/10.1109/TAP.2019.2893229> (2019).
42. Kasem, F., Winter, R., Feghhi, R., Rambabu, K. & Krzymien, W. A. Design of a low-cost low-profile energy efficient 64-qam load modulator. *IEEE Trans. Microw. Theory Tech.* **70**, 2246–2257. <https://doi.org/10.1109/TMTT.2022.3148359> (2022).

43. Liao, W.-C. *et al.* mmwave metal bowtie slot array element integrating power amplifier mmic via on-chip probe to enhance efficiency and bandwidth. *IEEE Trans. Antennas Propag.* **70**, 8110–8121. <https://doi.org/10.1109/TAP.2022.3177524> (2022).
44. Montaser, A. M. & Mahmoud, K. R. Design of intelligence reflector metasurface using deep learning neural network for 6g adaptive beamforming. *IEEE Access* **10**, 117900–117913. <https://doi.org/10.1109/ACCESS.2022.3220701> (2022).
45. Kouhalvandi, L., Ceylan, O. & Ozoguz, S. Automated top-down pruning optimization approach in rf power amplifier designs. *Analog Integr. Circ. Sig. Process* **106**, 525–534. <https://doi.org/10.1007/s10470-020-01730-w> (2021).
46. Yarman, S. *Design of Ultra Wideband Power Transfer Networks* (Wiley, 2010). <https://doi.org/10.1002/9780470688922>.
47. Kouhalvandi, L., Ceylan, O. & Yagci, H. B. Power amplifier design optimization with simultaneous cooperation of eda tool and numeric analyzer. In *2018 18th Mediterranean Microwave Symposium (MMS)* 202–205. <https://doi.org/10.1109/MMS.2018.8611955> (2018).
48. Mir, F., Kouhalvandi, L., Matekovits, L. & Gunes, E. O. Electromagnetic bottom-up optimization for automated antenna designs. In *2020 IEEE Asia-Pacific Microwave Conference (APMC)* 792–794. <https://doi.org/10.1109/APMC47863.2020.9331411> (2020).
49. Multi-objective particle swarm optimization (MOPSO) (2023, accessed 18 Mar 2023). [http://www.mathworks.com/matlabcentral/fileexchange/62074-multi-objective-particle-swarm-optimization-mopso?s\\_tid=FX\\_rc1\\_behav](http://www.mathworks.com/matlabcentral/fileexchange/62074-multi-objective-particle-swarm-optimization-mopso?s_tid=FX_rc1_behav).
50. Find multi-objective pareto front using modified quicksort (PFUMQ) (2023, accessed 18 Mar 2023). <http://www.mathworks.com/matlabcentral/fileexchange/73089-find-multi-objective-pareto-front-using-modified-quicksort>.
51. Bradford, E., Schweidtmann, A. M. & Lapkin, A. Efficient multiobjective optimization employing gaussian processes, spectral sampling and a genetic algorithm. *J. Glob. Optim.* **71**, 407–438. <https://doi.org/10.1007/s10898-018-0609-2> (2018).
52. Zhu, H., Liu, L., Long, T. & Peng, L. A novel algorithm of maximin latin hypercube design using successive local enumeration. *Eng. Optimiz.* **44**, 551–564. <https://doi.org/10.1080/0305215X.2011.591790> (2012).
53. 2-terminal physical transmission line (2022, accessed 5 May 2022). <http://edadocs.software.keysight.com>.
54. Kouhalvandi, L. & Matekovits, L. *Multi-objective Optimization Methods for Passive and Active Devices in mm-Wave 5G Networks* 337–371 (Springer International Publishing, 2022).
55. Kouhalvandi, L., Mir, F. & Matekovits, L. Patch antenna array design through bottom-up and bayesian optimizations. In *2021 IEEE International Symposium on Antennas and Propagation and USNC-URSI Radio Science Meeting (APS/URSI)* 779–780. <https://doi.org/10.1109/APS/URSI47566.2021.9703781> (2021).
56. Chen, P., Merrick, B. M. & Brazil, T. J. Bayesian optimization for broadband high-efficiency power amplifier designs. *IEEE Trans. Microw. Theory Tech.* **63**, 4263–4272. <https://doi.org/10.1109/TMTT.2015.2495360> (2015).
57. Cho, H. *et al.* Basic enhancement strategies when using bayesian optimization for hyperparameter tuning of deep neural networks. *IEEE Access* **8**, 52588–52608. <https://doi.org/10.1109/ACCESS.2020.2981072> (2020).
58. Kutilahti, V.-P., Lehtovuori, A. & Viikari, V. Analyzing and optimizing the eirp of a phase-tunable amplifier-antenna array. *IEEE J. Microwaves* **3**, 52–59. <https://doi.org/10.1109/JMW.2022.3207952> (2023).
59. Chappidi, C. R. & Sengupta, K. Globally optimal matching networks with lossy passives and efficiency bounds. *IEEE Trans. Circuits Syst. I Regul. Pap.* **65**, 257–269. <https://doi.org/10.1109/TCSI.2017.2720179> (2018).
60. Nallandhigal, S. N., Bayat-Makou, N. & Wu, K. Scalable planar active array antenna integrated with distributed amplifying transistors for high-power applications. *IEEE Trans. Microw. Theory Tech.* **69**, 3425–3437. <https://doi.org/10.1109/TMTT.2021.3073405> (2021).

## Author contributions

Conceptualization, L.K.; methodology, L.M.; investigation, L.K. and L.M.; resources, L.M.; data curation, L.K.; writing—original draft preparation, L.K.; writing—review and editing, L.M.; visualization, L.K.; supervision, L.M.; project administration, L.M.; funding acquisition, L.M. All authors have read and agreed to the published version of the manuscript. All authors reviewed the manuscript.

## Competing interests

The authors declare no competing interests.

## Additional information

**Correspondence** and requests for materials should be addressed to L.M.

**Reprints and permissions information** is available at [www.nature.com/reprints](http://www.nature.com/reprints).

**Publisher's note** Springer Nature remains neutral with regard to jurisdictional claims in published maps and institutional affiliations.



**Open Access** This article is licensed under a Creative Commons Attribution-NonCommercial-NoDerivatives 4.0 International License, which permits any non-commercial use, sharing, distribution and reproduction in any medium or format, as long as you give appropriate credit to the original author(s) and the source, provide a link to the Creative Commons licence, and indicate if you modified the licensed material. You do not have permission under this licence to share adapted material derived from this article or parts of it. The images or other third party material in this article are included in the article's Creative Commons licence, unless indicated otherwise in a credit line to the material. If material is not included in the article's Creative Commons licence and your intended use is not permitted by statutory regulation or exceeds the permitted use, you will need to obtain permission directly from the copyright holder. To view a copy of this licence, visit <http://creativecommons.org/licenses/by-nc-nd/4.0/>.

© The Author(s) 2024