

POLITECNICO DI TORINO  
Repository ISTITUZIONALE

On site data gathering by a collaborative network to assess durability, reliability, service life, and maintenance performance

*Original*

On site data gathering by a collaborative network to assess durability, reliability, service life, and maintenance performance / Villa, Valentina; Piantanida, Paolo; Vottari, Antonio. - In: TEMA. - ISSN 2421-4574. - ELETTRONICO. - 9:2(2023), pp. 149-159. [10.30682/tema090011]

*Availability:*

This version is available at: 11583/2990862 since: 2025-02-16T18:46:57Z

*Publisher:*

Bologna University Press

*Published*

DOI:10.30682/tema090011

*Terms of use:*

This article is made available under terms and conditions as specified in the corresponding bibliographic description in the repository

*Publisher copyright*

(Article begins on next page)



VOL. 9, NO. 2 (2023)

**KNOWLEDGE AND SCIENCE ON BUILDING TECHNOLOGIES.  
MEANS, INSTRUMENTS AND MODELS**

**TEMA**  
Technologies  
Engineering  
Materials  
Architecture

e-ISSN 2421-4574  
DOI: 10.30682/tema0902

**Journal Director:** R. Gulli

**Assistant Editors:** R. Albatici, A. Ferrante, G. Margani

**Cover illustration:** Stereotomic helical staircase in Villa D'Este, Tivoli, Italy.  
© Riccardo Gulli (2022)



e-ISSN 2421-4574

ISBN online 979-12-5477-367-3

DOI: 10.30682/tema0902

Vol. 9, No. 2 (2023)

Year 2023 (Issues per year: 2)

**Editor in chief**

Riccardo Gulli, Università di Bologna

**Associated Editors**

Annarita Ferrante – Università di Bologna

Enrico Quagliarini – Università Politecnica delle Marche

Giuseppe Margani – Università degli Studi di Catania

Fabio Fatiguso – Università Politecnica di Bari

Rossano Albatici – Università di Trento

**Editorial Board Members**

Ihsan Engin Bal, Hanze University of Applied Sciences – Groningen

Cristiana Bartolomei, University of Bologna

Antonio Becchi, Max Planck Institute – Berlin

Marco D’Orazio, Università Politecnica delle Marche

Vasco Peixoto de Freitas, Universidade do Porto – FEUP

Stefano Della Torre, Politecnico di Milano

Giuseppe Di Giuda, Università di Torino

Luca Guardigli, Università di Bologna

José Luis Gonzalez, UPC – Barcellona

Alfonso Ippolito, Sapienza University of Rome

Francisco Javier Neila Gonzalez, UPM Madrid

Alberto Grimoldi, Politecnico di Milano

Antonella Guida, Università della Basilicata

Santiago Huerta, ETS – Madrid

Richard Hyde, University of Sydney

Tullia Iori, Università di Roma Tor Vergata

Raffaella Lione, Università di Messina

John Richard Littlewood, Cardiff School of Art & Design

Camilla Mileto, Universidad Politecnica de Valencia UPV – Valencia

Renato Morganti, Università dell’Aquila

Antonello Sanna, Università di Cagliari

Matheos Santamouris, University of Athens

Enrico Sicignano, Università di Salerno

Lavinia Chiara Tagliabue, Università di Torino

Simone Helena Tanoue Vizioli, University of São Paulo

Claudio Varagnoli, Università di Pescara

Emanuele Zamperini, Università di Firenze

**Assistant Editors**

Cecilia Mazzoli, Università di Bologna

Davide Prati, Università di Bergamo

Anna Chiara Benedetti, Università di Bologna

**Journal director**

Riccardo Gulli, Università di Bologna

---

**Publisher:**

Ar.Tec. Associazione Scientifica per la Promozione dei Rapporti tra Architettura e Tecniche per l’Edilizia

c/o DICATECH - Dipartimento di Ingegneria Civile, Ambientale, del Territorio, Edile e di Chimica - Politecnico di Bari

Via Edoardo Orabona, 4

70125 Bari - Italy

Phone: +39 080 5963564

E-mail: [info@artecweb.org](mailto:info@artecweb.org) - [tema@artecweb.org](mailto:tema@artecweb.org)

**Publisher Partner:**

Fondazione Bologna University Press

Via Saragozza 10

40123 Bologna - Italy

Phone: +39 051 232882

[www.buonline.com](http://www.buonline.com)

**TEMA: Technologies Engineering Materials Architecture****Vol. 9, No. 2 (2023)**

e-ISSN 2421-4574

|   |           |
|---|-----------|
| <b>Editorial</b>  | <b>5</b>  |
| <b>Knowledge and science on building technologies. Means, instruments and models</b><br><i>Riccardo Gulli</i><br>DOI: 10.30682/tema090013   |           |
| <b>Compressed-air foundations in Italy: HBIM-aided study of the Tiber River embankments (1876-1900)</b><br><i>Ilaria Giannetti, Stefania Mornati</i><br>DOI: 10.30682/tema090005  | <b>6</b>  |
| <b>Autarky metal roofing at the Mecenate Paper Mill in Tivoli: an unseen application of Gino Covre's patents</b><br><i>Edoardo Currà, Andrea De Pace, Riccardo Rocchi, Alessandro D'Amico, Martina Russo, Marco Angelosanti, Ana Cardoso De Matos, Vicente Julian Sobrino Simal</i><br>DOI: 10.30682/tema090007 | <b>19</b> |
| <b>Digital representation strategies to reveal the cultural significance of Canadian Post-war Architecture</b><br><i>Davide Mezzino, Pierre Jouan</i><br>DOI: 10.30682/tema090002   | <b>33</b> |
| <b>Beyond the appearance. Overwritten heritage communication</b><br><i>Alfonso Ippolito, Giulia Luffarelli, Simone Helena Tanoue Vizioli</i><br>DOI: 10.30682/tema090009  | <b>46</b> |
| <b>Architecture and civic engagement. An ethical balance between social, architectural, structural, and energy issues in the redevelopment of existing building stock</b><br><i>Barbara Angi, Alberto Soci</i><br>DOI: 10.30682/tema090010  | <b>58</b> |
| <b>Greenery as a mitigation strategy to urban heat and air pollution: a comparative simulation-based study in a densely built environment</b><br><i>Graziano Salvalai, Juan Diego Blanco Cadena, Enrico Quagliarini</i><br>DOI: 10.30682/tema090003   | <b>67</b> |
| <b>Green roof as a passive cooling technique for the Mediterranean climate: an experimental study</b><br><i>Stefano Cascone, Federica Rosso</i><br>DOI: 10.30682/tema090006   | <b>84</b> |

|  |            |
|--|------------|
| <b>Virtual reality as a new frontier for energy behavioural research in buildings: tests validation in a virtual immersive office environment</b><br><i>Arianna Latini, Elisa Di Giuseppe, Marco D'Orazio</i><br>DOI: 10.30682/tema090001    | <b>95</b>  |
| <b>Construction Productivity Graph: a comprehensive methodology based on BIM and AI techniques to enhance productivity and safety on construction sites</b><br><i>Francesco Livio Rossini, Gabriele Novembri</i><br>DOI: 10.30682/tema090008 | <b>108</b> |
| <b>A genetic algorithm-based approach for the time, cost, and quality trade-off problem for construction projects</b><br><i>Marco Alvise Bragadin, Kalle Kähkönen, Luca Pozzi</i><br>DOI: 10.30682/tema090012                                | <b>121</b> |
| <b>Managing people's flows in cultural heritage to face pandemics: identification and evaluation of combined measures in an Italian arena</b><br><i>Marco D'Orazio, Gabriele Bernardini, Enrico Quagliarini</i><br>DOI: 10.30682/tema090004  | <b>135</b> |
| <b>On site data gathering by a collaborative network to assess durability, reliability, service life, and maintenance performance</b><br><i>Valentina Villa, Paolo Piantanida, Antonio Vottari</i><br>DOI: 10.30682/tema090011               | <b>149</b> |

# ON SITE DATA GATHERING BY A COLLABORATIVE NETWORK TO ASSESS DURABILITY, RELIABILITY, SERVICE LIFE, AND MAINTENANCE PERFORMANCE

Valentina Villa, Paolo Piantanida, Antonio Vottari

DOI: 10.30682/tema090011



e-ISSN 2421-4574  
Vol. 9, No. 2 - (2023)

This contribution has been peer-reviewed.  
© Authors 2023. CC BY 4.0 License.

## Abstract

Any maintenance service could benefit from automatic and intelligent fault detection and diagnostics (intelligent AFDDs) to monitor building systems. Here, a system for FCUs (fan coils) is tailor-made to take full advantage of Collaborative Networking 4.0. Big data is collected by interconnected Internet of Things sensors and transferred to the cloud after local intelligence has identified which data is really significant for cloud transmission: to avoid network overload, anomaly detection and fault diagnostics are entrusted to local intelligence, cloud sending only out-of-range data and a very low-frequency sampling for standard data.

By feeding the network with only the relevant processed data and sharing the information at each level, the resulting AFDD system becomes a collaborative network capable of extending the diagnostic process to the entire building, making it accessible through integration into an appropriate BIM model.

Real-time data monitoring is vital to managing the facility maintenance service sustainably, but collecting big data on a wide scale enables other possibilities. For example, component service life rating (to support a procurement service) and maintenance effectiveness by comparing the after-service values with the data recorded at the component's acceptance.

## Keywords

BIM modelling, Big data, Automated Fault Diagnostic, Fan Coil Unit, Smart sensors.

## Valentina Villa\*

*DISEG - Dipartimento di Ingegneria Strutturale, Edile e Geotecnica, Politecnico di Torino, Torino (Italy)*

## Paolo Piantanida

*DISEG - Dipartimento di Ingegneria Strutturale, Edile e Geotecnica, Politecnico di Torino, Torino (Italy)*

## Antonio Vottari

*DISEG - Dipartimento di Ingegneria Strutturale, Edile e Geotecnica, Politecnico di Torino, Torino (Italy)*

\*Corresponding author:  
e-mail: [valentina.villa@polito.it](mailto:valentina.villa@polito.it)

## 1. INTRODUCTION

Nowadays, new possibilities in terms of cognitive and decision-making processes for building facilities management are supported by the latest technological advances as well as the development of emerging paradigms such as collaborative networks 4.0 (CN 4.0), Internet of Things (IoT) platforms and Big Data management [1].

In particular, facility maintenance service (FMS) could benefit from an integrated approach between facility managers (FM) and decision-makers (DM), provided

that this type of method is based on data collection and immediate integration and interoperability.

IoT platforms allow FMs, FMSs and facility managers to share the same open IoT environment that enables the convergence of various technologies (building management systems, sensors and connectivity), resulting in more sustainable building management [2]. Furthermore, the adoption of IoT enables FMS, DM and FM operators to recognise and apply new state-of-the-art techniques. Indeed, the idea of an IoT platform is growing rapidly,

as it can provide a single, integrated framework for data management, provided that operators, and the FMS in particular, accept and collaborate on the concept of centralising data.

For instance, according to Katipamula, S. & Brambley [3], poorly managed and degraded machinery wastes between 15% and 30% of the electricity used in commercial building systems, and we can suppose a similar impact in the other kinds of buildings. However, most of this waste could be avoided if state-based automated maintenance requests were adopted on a large scale. Most of the research on AFDD is focused on heating, ventilation and air conditioning (HVAC) systems or, more specifically, air handling units (AHU) and fan coil units of buildings. Over the last few decades, extensive study in the field of AFDD has been undertaken to classify various techniques that are appropriate for building HVAC and AHU systems by authors of [4–6], considering physical redundancy, heuristics or statistical bands, including the control chart approach, pattern recognition techniques, and innovation-based methods or hypothesis testing on physical models to detect faults. For fault isolation, the authors use information flow diagrams, expert systems, semantic networks, artificial neural networks, parameter estimation methods, and various AFDD software and hardware that have been produced as study results. However, assessing the reliability of various AFDD systems is a challenging task, and developing a more reliable AFDD system for building facility management involves professionals and practitioners from different areas working in collaboration [7].

Basically, AFDD is intended to help with facility maintenance service (FMS). So far, we have not had any significant spillover into the design process or procurement phase. Expected Service Life data in real working conditions could actively support the decisional process, e.g., which components are the best choice.

This paper illustrates the design of a collaborative network AFDD system intended for building facility maintenance, its preliminary testing on a fan-coil, and the potential long-term extension of the use of the acquired data in statistical terms to feed a possible national database on the reliability of individual components in specific usage situations. The paper is organised as fol-

lows: after introduction, faults detection methodology on local sensor node is introduced, and then the IoT & BIM-based fault diagnostic approach is outlined, and a possible statistic fallout towards a national ESL rating and maintenance rating are summarised. The collected data from sensors are integrated into the BIM model and linked in real-time to a dashboard for trend visualisation. The BIM model is used to visualise the location of the element and get an overview of the building; in the future, it could also be used to verify the ESL history of any specific component or technology choice, checking the effectiveness of procurement after the fact, and the efficacy and effectiveness of the maintenance intervention.

## 2. WHAT FOR SMART & DISTRIBUTED FAULT DETECTION?

The research first focused on the need for an effective failure and performance degradation detection system.

Two strategies were possible.

The first, typical of building management sensing, would have employed sensors specific to indoor environmental control to monitor the evolution of environmental parameters, whose deviation from design values would have identified the fault condition or, rather, the effect of the fault condition on the environmental system.

The second, typical of machine control in industry, would have required dedicated sensing to monitor the component behavior (FCU), with the advantage of having an AFDD system embedded in the component and autonomous from the building. In addition, the system can directly detect the actual fault condition on the component and not its impact on the internal environmental parameters.

In this way, the influence of environmental conditions is all but eliminated, and detected anomaly conditions (e.g., the FC does not heat) do not interfere with any management anomaly conditions (e.g., insufficient room temperature for FC off or open windows).

The second option has been set as a goal to design the AFDD system.

Facilities' elements must be equipped with sensors to detect faults in building systems automatically. One of the most common components in building structures is the fan coil unit (FCU), which is part of the heating, ven-

| Sensor node                                       | Sensor name            | Location and variable names on the fan coil | Max. and Min. Measuring ranges | Accuracy | Units      |
|---|------------------------|---|--------------------------------|----------|------------|
| RPIZCT4V3T2 (Raspberry Pi Zero W and Arduino MCU) | Current (SCT-013-000)  | i1, i2, i3                                  | 0-100A                         | ±3       | Ampere(A)  |
|   | Voltage (77DE-06-09)   | v1, v2, v3                                  | 0-230 (50Hz)                   | ±5       | Volt(V)    |
|   | Temperature DS18B20    | T1, T2, T3, T4                              | 0°– 90°C                       | ±0.5     | Celsius(C) |
|   | Temperature RTD(PT100) | T5  | -200° to 550°C                 | ±0.05    | Celsius(C) |

Tab. 1. Implemented sensor board and sensors specifications.

tilation and air conditioning (HVAC) system and uses a water coil and fan to heat or cool rooms. A fan coil unit with motor model FC83M - 2014/1 in 3-speed version (high, medium and low) was used as a case study. At maximum speed, the FC motor runs at 1100 revolutions per minute (RPM) counterclockwise. In addition, the FC is equipped with a single cooling/heating coil and filters to protect the blower and coil from dust clogging.

Specific sensors are required to develop a sensor-based fan coil monitoring for an automatic fault detection system. The measuring parameters and measuring ranges of the sensors vary depending on the internal components of the fan coil. Considering these features, specific sensors and sensor boards that host all sensors are selected for this project and described in Table 1.

In addition, sensor sampling rates are important so as not to lose key features, while the storage of incoming data in the database is tailored to avoid overloading the system by reiterating stable and redundant parameters. Configured data acquisition sampling frequencies of each sensor are listed in Table 2.

| Sensors    | Frequency  | Sensor allocation                 |
|------------|------------|-----------------------------------|
| T1         | 180"       | water in                          |
| T2         | 180"       | water out                         |
| T3         | 180"       | air intake                        |
| T4         | 180"       | air outlet                        |
| T5         | 10"        | motor case                        |
| v1, v2, v3 | 0,1"       | motor voltage (speed I, II, III)  |
| i1, i2, i3 | 0,05" / 3" | Motor currents (speed I, II, III) |

Tab. 2. Sampling frequencies of sensors.

T1, T2 and T4 sensors (see Fig. 1) measure temperature in the range between  $0 \div 90^\circ\text{C}$ . T3 is applied to measure the air temperature in the range  $0 \div 50^\circ\text{C}$  and T5 is devoted to monitoring the motor case temperature in the range between  $0^\circ$  to  $200^\circ\text{C}$ . Voltage and current sensors are connected to the fan coil's power line to monitor the motor's behaviour at each of the three speeds. The RPIZCT4V3T2 board is programmed so that coming data from sensors are sorted according to the importance of the data and locally stored or delivered to the cloud database.

The RPIZCT4V3T2 board is equipped with an Arduino microcontroller (MCU) and connected to the temperature sensors. Current and voltage sensors are connected to the MCU through an amplifier and analog-to-digital converter (ADC). Additionally, on the RPIZCT4V3T2 board, MCU is connected to the Raspberry Pi (Rpi) Zero W via general-purpose input-output (GPIO) pins. RPi Zero W is a single-board computer with an integrated Wi-Fi module. The board is programmed to collect raw data from sensors, and then the MCU processes the necessary values and sends the final computation to the Rpi Zero W using the Universal Asynchronous Receiver-Transmitter (UART) serial port.

A Node-Red is installed on the Rpi Zero W, providing real-time access to the sensors' data through serial protocols and displaying them on local dashboards. MQTT flow on the Rpi Zero W is intended to send (Publishing) a message to the cloud server, which will act as a receiver (Subscriber) using Message Queue Telemetry Transport

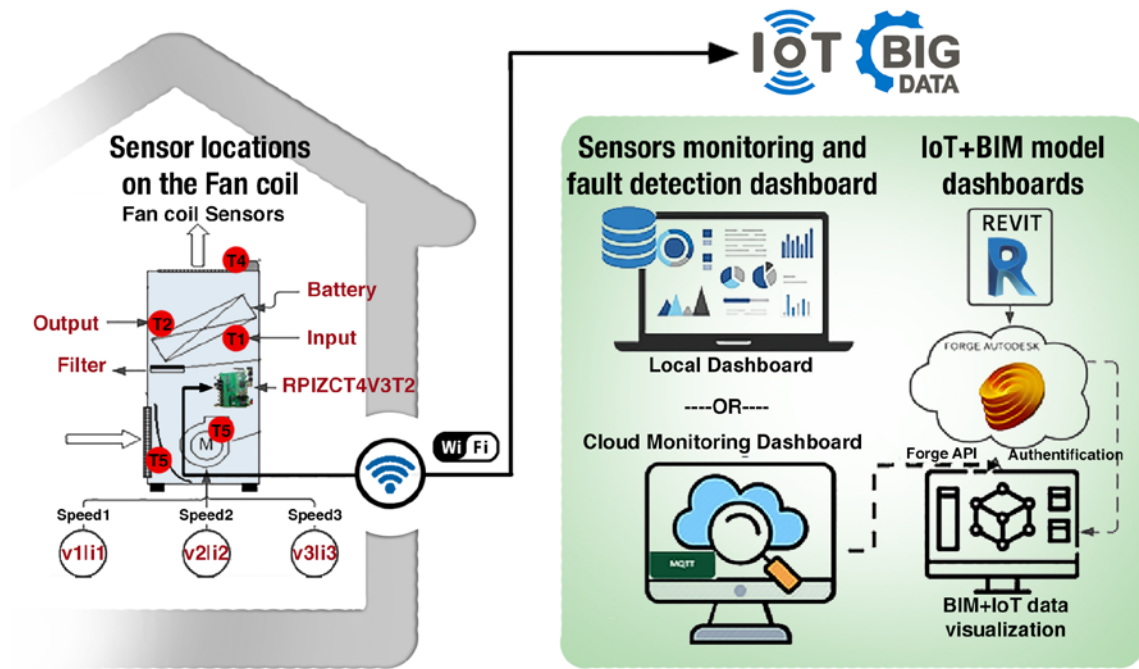

Fig. 1. From distributed local smart sensors to cloud monitoring and BIM 3D model integrated dashboard.

(MQTT) protocol, an OASIS standard messaging protocol for IoT (so light that is ideal for connecting remote devices with a small code footprint and minimal network bandwidth [8]).

Moreover, DNSmasq free software is installed to use the Rpi Zero W as a router, providing a communication bridge between internal sensors and external components by protocol (IP) addresses.

MySQL database, PHP interpreter, and Apache web server are utilised to store sensor data locally on the Rpi Zero W. The Connection diagram between components and sensors of the local fault detection system based on the RPIZCT4V3T2 board is summarised in Fig. 2.

While running the system, all sensors start to collect data from the FCU, and the accounted end-user can access the Rpi Zero W using the static IP address of the board. On the board, Node-Red and MQTT provide access to the external devices. Moreover, MySQL database flow is installed and configured to the PHP interpreter to store collected data locally using the Apache web server. By powering the Rpi Zero W, MySQL gets the IP address, opens the configured port, and waits for Node-Red to send data that must be collected and allocated to the linked tables. Collected MySQL data can be connected to the BIM using a data-driven approach or directly using Forge nodes on the Node-Red.

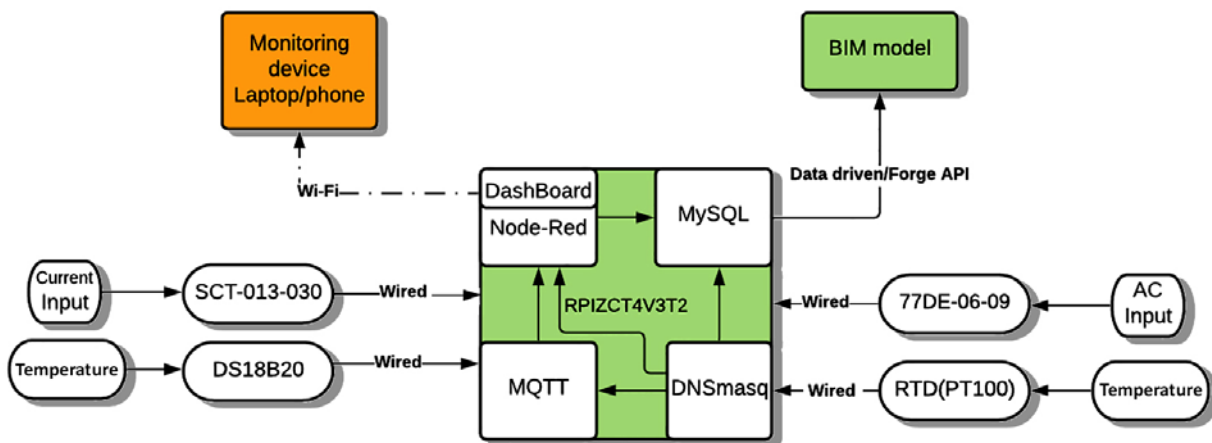

Fig. 2. Anomalies detection network: local and cloud monitoring [9].

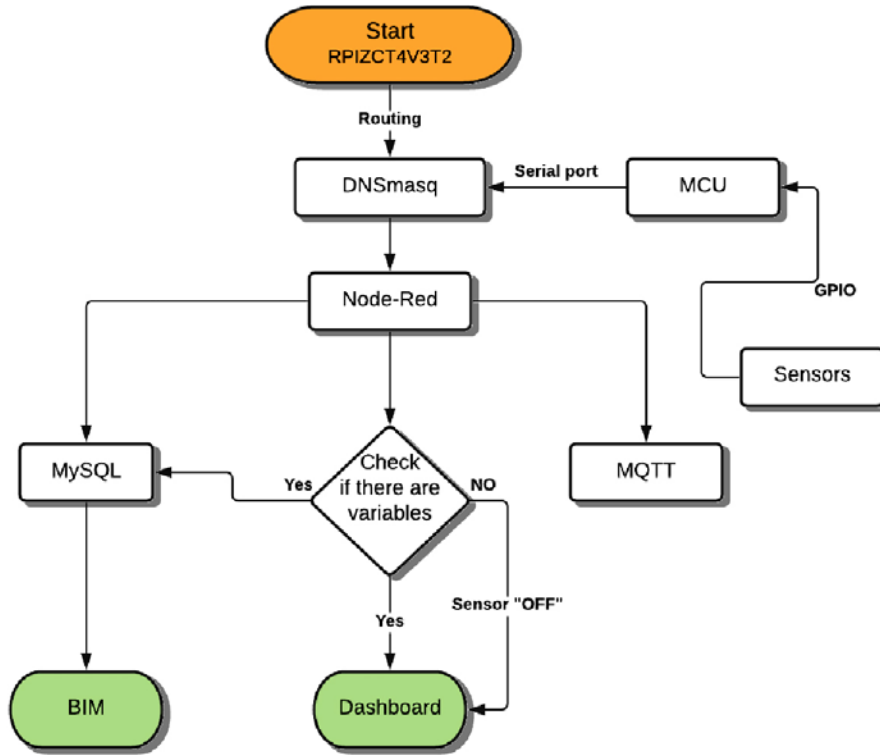

Fig. 3. Functional diagram of the data acquisition system [9].

The research work developed customised add-ons on the Visual Studio Code for Autodesk Forge Viewer so that collected IoT data and the 3D building model of Revit can be visualised together on the Forge Viewer using URL and PORT provided by Forge API. The fault

detection system connectivity diagram with sensors and related components is shown in Fig 3.

FCU condition monitoring dashboard was realised on the Rpi Zero W Node-Red graphical user interface (GUI). Node red flows were created to develop a fan-coil

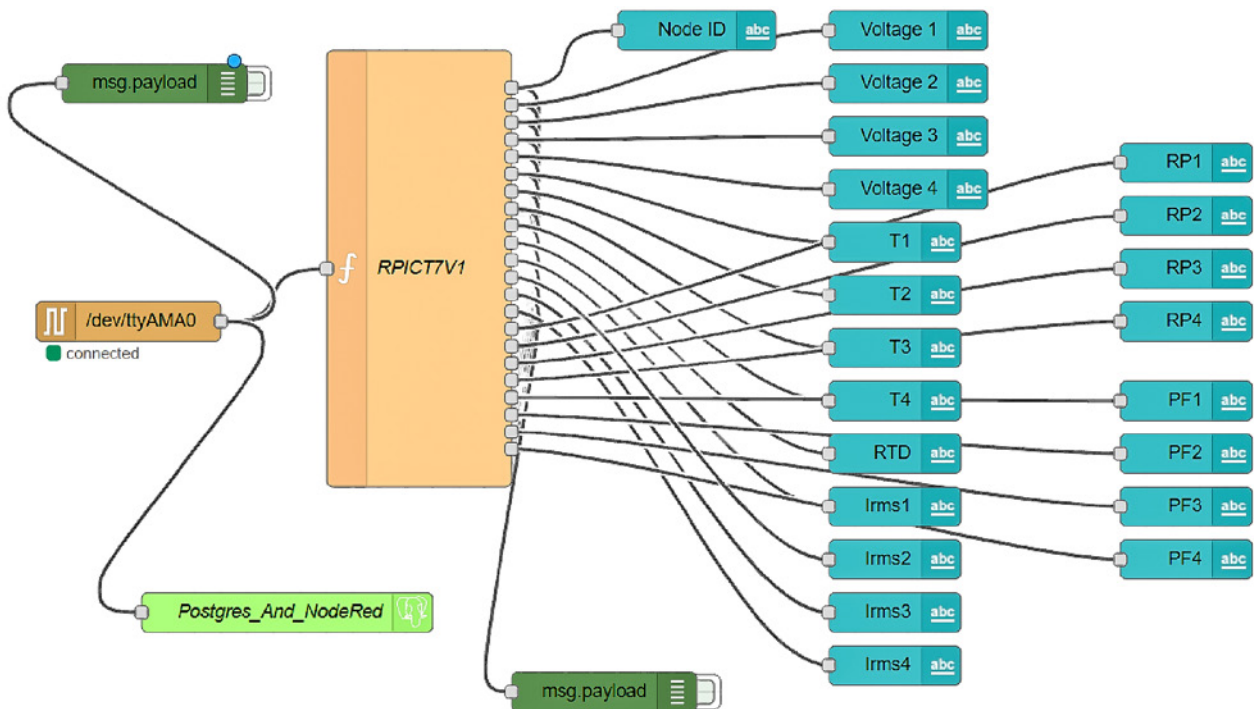

Fig. 4. Node-red Fan coil monitoring flow [9].

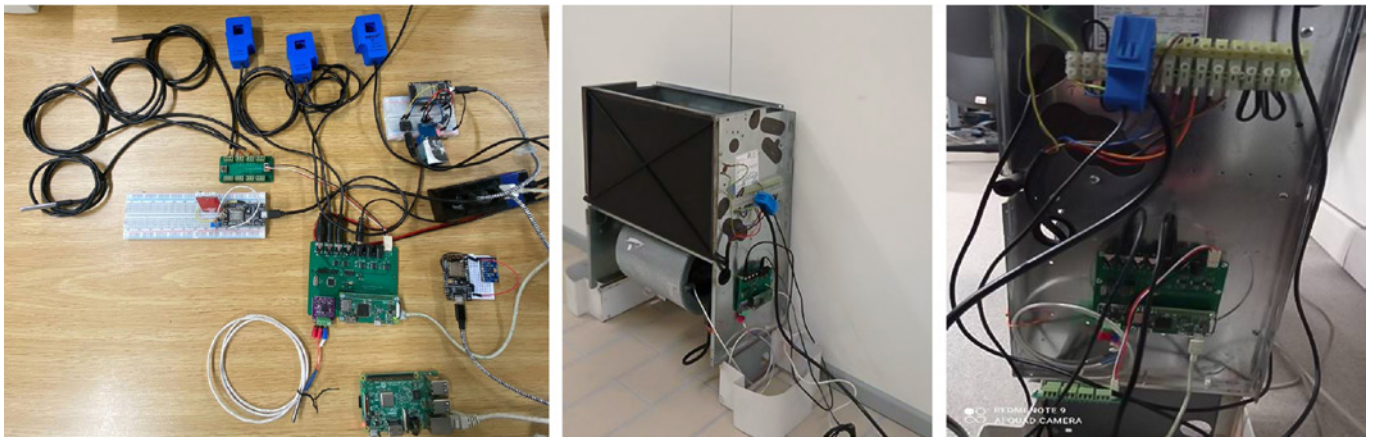

Fig. 5. (a) sensing system; (b) sensors equipped FCU; (c) Raspberry board and Arduino microcontroller.

dashboard. By using the serial port node, sensors' data coming to the MCU are registered as a string. Special functions on the Node-Red flow were developed to split and convert the data from the serial port into the dashboard. Fig. 4 shows the fan coil monitoring flow on the Node-red.

### 3. FAULT DIAGNOSTIC THROUGH IOT

#### 3.1. RELIABILITY IN FAULT MANAGEMENT

Failure or abnormal operation of an FC unit may be due to external causes (e.g., lack of or poor water flow, or water temperature insufficient to cover thermal loads; supply voltage anomalies, etc.) or internal causes (e.g., clogged air passages, slowed or blocked motor, etc.).

Automatic and unambiguous fault detection is a necessary condition for reliable fault management, subsequent corrective actions, and consequent statistical data collection for quality assessment. Otherwise, there would be false alarms and idle interventions that would likely turn off the system and, more importantly, run against the sustainability of the maintenance-by-repair vs. maintenance-by-replacement model.

The situation is monitored through a set of sensors. Particularly, five temperature sensors are available (T1 for supply water temperature, T2 for return water temperature, T3 for inlet air temperature, T4 for outlet air temperature, T5 for motor casing temperature), three voltage sensors are available (v1 for power supply voltage at motor speed 1, v2 for power supply voltage at

motor speed 2, v3 power supply voltage at motor speed 3), and three current sensors are available (i1 for current absorbed by the motor at speed 1, i2 for current absorbed by the motor at speed 2, i3 current absorbed by the motor at speed 3). Each sensor was selected according to the accuracy class of the measurement, considering its sensitivity and accuracy, as shown in Table 1.

#### 3.2. DIGITAL TWIN'S ID

In an ideal situation, as soon as the FCU pass the acceptance test, the sensors provide the control system with data of the original situation, that is, a kind of ID card of the digital twin under those particular operating conditions. The FM service can easily update this identity card if something has changed (components, operating conditions, facility update, etc.), e.g., similar to what happens whenever tires are changed and a tire monitoring system is involved, with the permission of the FM supervisor (and the change recorded in the database).

Once the ID card for that FCU is acquired, its values are continuously compared with those detected by the sensors in real-time and their drifts are processed to detect anomalies and faults.

#### 3.3. WHAT'S WRONG?

An FCU that works appropriately meets the heat load on time and operates without harassing vibrations.

A temperature difference between the water inlet and outlet must be evaluated in relation to the temperature of

the air entering the coil (room air). If this is in the normal range, the water-side thermal drop should also be comparable to the original one: smaller thermal gaps indicate decreased exchange capacity of the coil (low air flow or scaled coil); larger thermal gaps indicate decreased water circulation.

This excluded, a temperature difference between inlet and outlet air that is significantly greater than the original one, indicating reduced airflow, either due to filter clogging or poor fan performance. The latter case, in turn, can be verified by examining the trend of the steady-speed current and the temperature of the motor, depending on the operating speed: if the motor temperature (single-phase with the capacitor permanently on) continues to rise, the capacitor is not working and needs to be replaced; if the steady-speed current is higher than the original one, the fan encounters abnormal resistance, for example, caused by bearing wear or presence of foreign objects in the blower.

But the start-up phase can also provide interesting data: first, checking that the voltage is correct and resets to zero during stops (eddy current detection) and, most importantly, that the start-up phase does not extend beyond the appropriate time mapped in the ID card: in the latter case, this would be excessive friction or capacitor decay. With proper reading accuracy, impeller imbalances can also be detected by estimating the higher current required in the half-turn in which the heavier part of the rotating mass is moved upward and comparing it with the lower current required when the same unbalanced mass “falls” downward, dragging the impeller’s rotation with it.

So, to diagnose the faults, the procedure reported in Fig. 6 in the form of a BPMN diagram is followed [10].

#### 4. REPRODUCING THE NETWORK OF SENSORS ON THE BIM

The sensor board memory is insufficient for Big Data storage: to avoid the overloading of the local memory, only daily maximum and minimum variables are permanently recorded and sent to the cloud and BIM server. The fault detection diagram described in the previous section is integrated into the system.

If any sensor has out-of-range values, the detecting system is designed to send real-time alarm signals or notifications to the accounted end-users, facility managers or maintenance services, depending on the kind of anomaly. Conditional data of the FCU has been transported to the BIM model of the building to support facility managers. This implementation was tested in a section of the Department of Structural, Building and Geotechnical Engineering (DISEG) at Politecnico di Torino (Italy). The local CPU and its set of sensors were installed simultaneously on one fan-coil unit to test whether their operation and calibration were replicable and reliable. Fault detection was almost always adequately sensitive, except for the current sensors used, which proved to require very accurate and specific calibrations for each motor. For this reason, the testing of the detection system is still ongoing and being improved. To visualise conditional data of the FCU on the 3D model of the building, sensors’ data are implemented to the BIM using the Forge Reference Application and two NPM modules (React UI components and Client-Server Data-Module-Components). The final custom application, IoT and BIM, developed on the JavaScript and Forge Platform, is shown in Fig. 8. The application supports a heatmap function, which changes the color of the 3D model of the fan coil according to the data coming from the sensor board. The color is “green” if the fan coil is ok, “red” if the motor is overheated, and “blue” if the fan coil is in poor working condition.

### 5. BIG DATA GATHERING: A PERSPECTIVE FOR LIFE CYCLE ASSESSMENT

#### 5.1. DIGITAL TWINS’ BIG DATA & MAINTENANCE SCHEDULING

The availability of big data handled through BIM (methodological) modelling is useful for improving maintenance strategies and activities. In the building process, the management phase is in some respects replicative of the building design process (prototyping and one-to-one relationships). It exploits the continuous monitoring of the degree to which the behaviour of components matches their digital twins in order to plan maintenance services, all taking into account the data for that specific

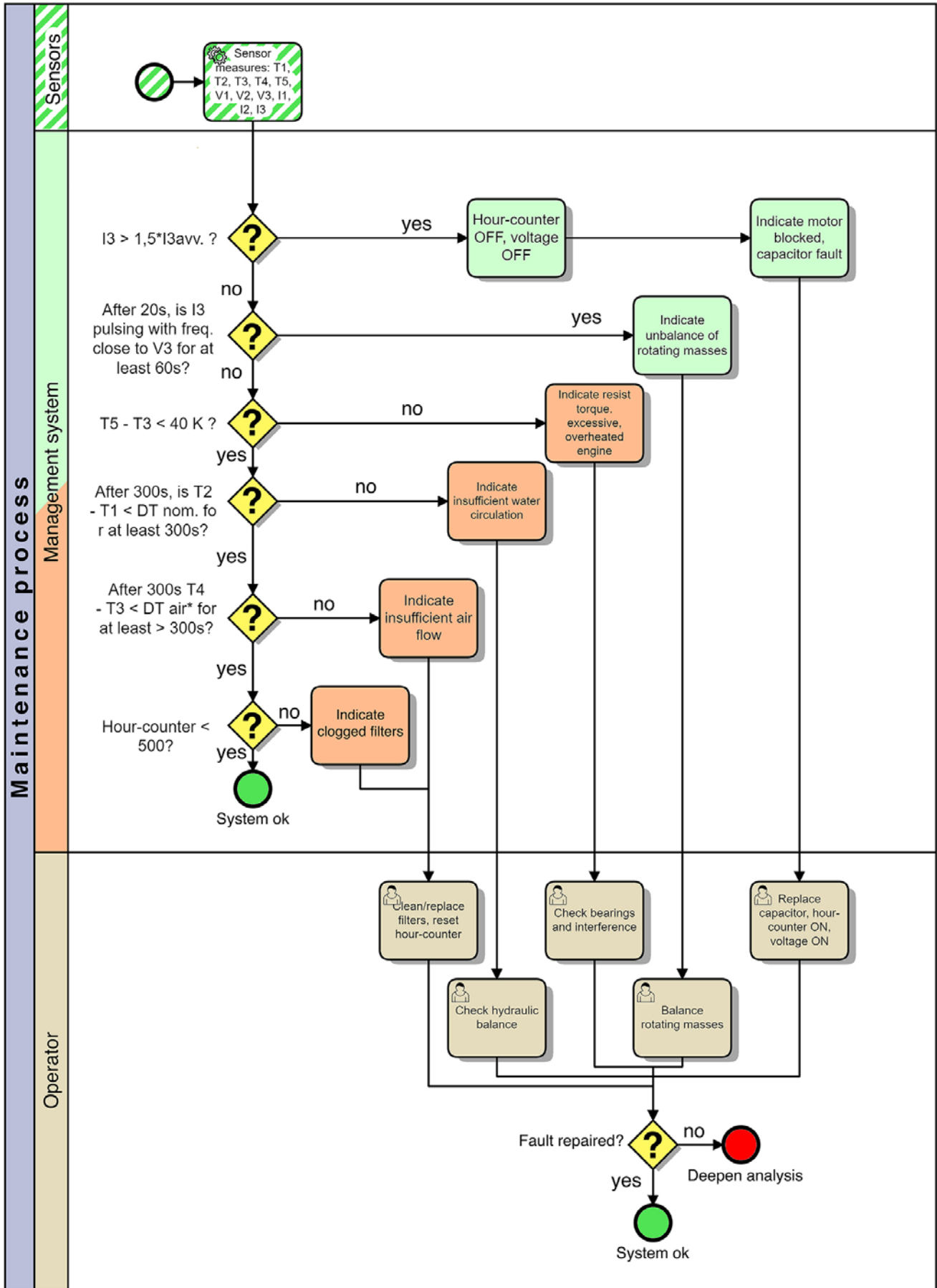

Fig. 6. Anomalies detection & maintenance controls flow chart.

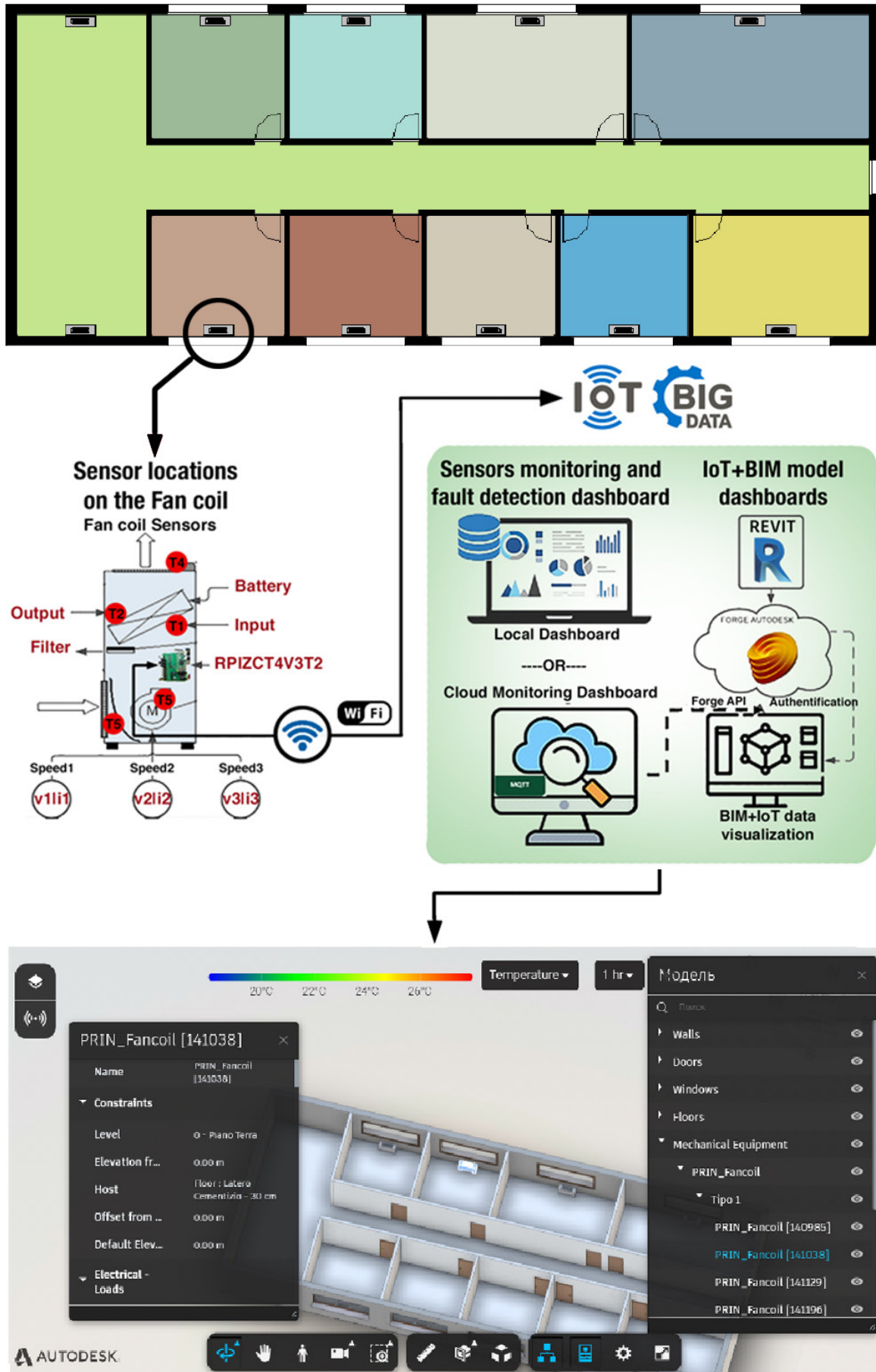

Fig. 7. Illustrative application of the BIM model with real-time FCUs monitoring to a wing of the DISEG (Politecnico di Torino).

situation in that particular building. That increases the sustainability of building components because it enhances their service lifespan by predictive maintenance, thus assisting both active (those who do it) and passive (those who suffer it) facility management. Better maintenance planning results in reduced wait for repair, the impact of outages, and idle visits (during periods of pandemic also associated with unwanted people-to-people contacts and quarantine restrictions).

## 5.2. DIGITAL BROTHERS' BIG DATA & PRODUCT PROCUREMENT

In the authors' opinion, collected data that now remain confined to the building or the appointed maintainer can instead open up to an innovative, integrated, holistic procurement slant, at least on a national market level, that will drive a shift in the building management approach.

As a matter of fact, if buildings remain for the vast majority prototypes of themselves, they integrate a significant number of components from industrial production, e.g., HVAC elements or lighting systems. Moreover, precisely, these components have a shorter service life than the building, and their performance decay to the point of failure determines a good deal of corrective maintenance, often inclined to replacement rather than on-site repair.

In the design process, there is a great deal of need to evaluate the service life of products, as the results will depend on both material properties and the environment in which the material is working. In the procurement process, the need is even greater: a sound working strategy towards this goal could be based on a good knowledge in the field of reliability of products in real-life conditions, similarly to what the AQC's Sycodés (*Système de collecte d'informations sur les désordres de la construction*, System for collecting information on construction disorders by the Agence Qualité Construction, Building Quality Agency) did in France [11] even helping the premium management of building insurance policies.

Big data gathering can feed such a new approach in building components' Life Cycle assessment towards a

favorable shift, recording not only that component's behavior but the Real Service Life of every same component in an analogous context, that is to say, nourishing the database with all of its digital 'brothers'. The statistical analysis of the digital brothers' data can lead to a sustainable holistic procurement: component selection is no longer a matter of price or performance in itself. It must be a carefully blended mix of adequate reliability (service lifespan) and serviceability. A 'never-fail' reliability will carry out of the market all the servicemen and their local knowledge and crafts, but also unserviceable components will lead to the same point because the maintenance strategy will be substitutive (the new component being probably made abroad) instead of reparative (the servicemen are necessarily local). Both lead to the same unsustainable general and permanent loss of workforce and skills.

## 5.3. DIGITAL GRANNIES' BIG DATA & MAINTENANCE RATING

Once the database has been populated with the data from the digital ID cards of the components in service, this data can also be used to verify and rate a service intervention. In fact, if, after the maintenance task, the data collected by the sensors are not at least as good as the original levels (i.e., the newborn 'digital twin' does not conform to his retired digital 'grandfather'), the maintenance intervention can be automatically rated as not fully effective, and if their decay is faster than the original, not fully efficient. In this way, the level of compatibility of new components with obsolete ones can also be classified with positive fallout on the quality of the procurement.

## 6. CONCLUSIONS

The new availability of big data in building information modelling is recognised as useful for improving maintenance strategies and activities that, possibly integrated into a digital (methodological) model, improve the environmental impact and sustainability of buildings' service life and their components. IoT sensor platform and wireless AFDD methodology to monitor and detect

faults require to be designed together: in particular, sensing strategy for building management (e.g., room temperature) should not be confused with the right sensing strategy for building maintenance (e.g., temperature in the components).

The actual behavioral model of the management phase is in some respects replicative of the building design process (prototyping and one-to-one relationships) and takes advantage of the continuous monitoring of the behavior of the components: if one of the best-known courses of sustainable action is in fact ‘think globally, act locally’, the building maintenance ethic till now pursued sound rather as ‘think locally, act locally’, very different from the industrial ethic which, facilitated by the seriality and generalised diffusion of its production, is oriented in the direction of ‘think globally, act globally’ (e.g. the general product recalls for construction defects). Big data managed towards Life Cycle Assessment can fill up this gap.

The proposed framework’s structure, which includes an IoT sensors dashboard, an IoT and BIM combined program, and a server-based preventive maintenance methodology for building facilities, demonstrates the framework’s applicability and the possibility of feeding big data analytics, such as a national database on building components to have reliability rating strategy for each of them or a local maintenance assessment and surveillance system (e. g. in terms of effectiveness and efficacy).

### Authors contribution

Conceptualisation, V.V., P.P.; data curation, A.V.; formal analysis, A.V. and P.P.; funding acquisition, V.V.; investigation, V.V. P.P. and A.V.; methodology, V.V. and P.P.; resources, A.V., P.P.; software, A.V. and V.V.; supervision, V.V.; validation, P.P.; visualisation, A.V.; writing-review & editing, V.V., P.P., A.V.

All authors have read and agreed to the published version of the manuscript.

### Funding

This research was funded by the Italian government, through the PRIN2017 project of the Ministero dell’Istruzione, dell’Università e della Ricerca (MIUR). The title of the project is “Distributed Digital Collaboration Framework for Small and Medium-Sized Engineering and Construction Enterprises”.

### References

- [1] Villa V, Naticchia B, Bruno G, Aliev K, Piantanida P, Antonelli D (2021) IoT Open-Source Architecture for the Maintenance of Building Facilities. *Appl Sci* 11:5374
- [2] Villa V, Bruno G, Aliev K, Piantanida P, Corneli A, Antonelli D (2022) Machine Learning Framework for the Sustainable Maintenance of Building Facilities. *Sustainability* 14(2):681. <https://doi.org/10.3390/su14020681>
- [3] Katipamula S, Brambley M R (2005) Methods for fault detection, diagnostics, and prognostics for building systems - a review, part I. *Hvac&R Research* 11(1):3–25
- [4] Yu Y, Woradechjumroen D, Yu D (2014) A review of fault detection and diagnosis methodologies on air-handling units. *Energy and Buildings* 82:550–562
- [5] Katipamula S, Brambley M R (2005) Methods for fault detection, diagnostics, and prognostics for building systems - A review, part II. *Hvac&R Research* 11(2):169–187
- [6] Talamo C (2020) Digital Transformation in Facility Management (FM). IoT and Big Data for Service Innovation. In: Daniotti B, Gianinetto M, Della Torre S (eds) *Digital Transformation of the Design, Construction and Management Processes of the Built Environment*, Research for Development. Springer, Cham, pp 267–278. [https://doi.org/10.1007/978-3-030-33570-0\\_24](https://doi.org/10.1007/978-3-030-33570-0_24)
- [7] Pourarian S, Wen J, Veronica D, Pertzborn A, Zhou X, Liu R (2017) A tool for evaluating fault detection and diagnostic methods for fan coil units. *Energy and Buildings* 136:151–160
- [8] MQTT: The Standard for IoT Messaging. <https://mqtt.org/>. Accessed on June 29, 2022
- [9] Aliev K, Antonelli D, Bruno G, Piantanida P, Villa V (2021) Building system diagnostics through a network of smart local sensors. In: *Design Automation, Computer Engineering, Computer Networks and Social Media Conference (SEEDA-CECNSM)*, 2021 6th South-East Europe. IEEE, Piscataway NJ
- [10] Object Management Group Business Process Model and Notation. <https://www.bpmn.org/>. Accessed on June 29, 2022
- [11] Agence Qualité Construction (2019) *Observatoire de la qualité de la construction*, AQC, Paris