

Development of a Mobility Platform Aiming to Achieve User-Friendly
Functionality

Original

Development of a Mobility Platform Aiming to Achieve User-Friendly
Functionality / Baglieri, Lorenzo; Matsuura, Daisuke; Kobayashi, Tsune; Quaglia, Giuseppe. - ELETTRONICO. -
7:(2024), pp. 103-110. (The 7th Jc-IFTToMM International Symposium Kitakyushu (Japan) 22-23/06/2024).

Availability:

This version is available at: 11583/2989802 since: 2024-06-24T05:33:45Z

Publisher:

Japanese Council of IFTToMM

Published

DOI:

Terms of use:

This article is made available under terms and conditions as specified in the corresponding bibliographic description in
the repository

Publisher copyright

(Article begins on next page)

Development of a Mobility Platform Aiming to Achieve User-Friendly Functionality

Lorenzo Baglieri

Department of Mechanical and Aerospace Engineering, Politecnico di Torino, Italy,
lorenzo.baglieri@polito.it

Daisuke Matsuura

Department of Mechanical Engineering, Tokyo Institute of Technology, Japan,
matsuura.d.aa@m.titech.ac.jp

Tsune Kobayashi

JTEKT Corporation and Dept. of Mech. Eng. Tokyo Institute of Technology, Japan,
kobayashi.t.cs@m.titech.ac.jp

Giuseppe Quaglia

Department of Mechanical and Aerospace Engineering, Politecnico di Torino, Italy,
giuseppe.quaglia@polito.it

Abstract

This paper presents the working principle and development of a personal mobility platform that is a part of a hand-free wheelchair project. The wheelchair design integrates two control levels, motor steering wheels, cameras, and IMUs, enabling precise motion control based on the rider's movements on a seat. The mobility platform, comprising two motor steering wheels and a passive caster wheel, is designed to satisfy wheelchair requirements of omnidirectional maneuverability. In this article, detailed descriptions of the platform components, including dimensions and functionality, are provided. Additionally, the motor steering wheel design is discussed, emphasizing its crucial role in providing motion and supporting the platform's weight. A preliminary experimental test result demonstrates the platform's capability to navigate in the environment. The results highlight the system's potential to enhance independent mobility and address challenges faced by individuals with mobility limitations.

Keywords: mobility platform, motion control, motor steering wheel, independent mobility.

1. Introduction

The population of medium age is constantly increasing and linked also people with walking diseases. In the European zone, the number of people with mobility limitations is over 120 million people by 2020 [1]. According to studies, people with severe disabilities have a very hard time learning how to operate a traditional power wheelchair. Up to 10% of people find it difficult or impossible to use a power wheelchair, another 10% find it impossible to steer without help, and 40% struggle with steering [2]. Moreover, omnidirectional movements perform better in narrow indoor environments [3].

Nowadays the use of new Human-Machine Interfaces (HMI) enables the development of intelligent wheelchairs. Various approaches developed innovative ways of wheelchair control with a free-hand interface: using EEG [4], voice commands [5], hand gestures [6], eye gaze [7], tactile information [8], Sip-and-Puff (the use of air pressure variation by inhaling or exhaling via a tube-like object, to generate command signals) [9], tongue [10]. The actual challenge in the research

environment is developing a wheelchair that fits with human life standards, developing HMI adapted to user disability and capability to assist the user in navigation (i.e. obstacle avoidance allows more safety operation of the wheelchair).

This article describes the development of an omnidirectional mobility platform aiming for personal use. It permits the development of the hand-free wheelchair that gives back independent mobility, inclusivity and social interaction thanks to a hand-free and side-by-side wheelchair. This aim also follows the Sustainable Development Goals of the UN in Good Health and Well-Being and Reducing Inequalities. The following sections detail the hardware and the software components that compose the platforms, the working principle and some demonstrative tests.

2. Wheelchair hand-free and Mobility Platform working principle

The working principle of the hand-free wheelchair, which contains the mobility platform, is shown in Fig. 1. The main components are two control levels, two motor steering wheels, a passive castor wheel, two cameras (Cam_R, Cam_L) and two IMU (IMU1 and IMU2). The control is split between high-level and low-level; the first one is executed in a PC with ROS and the second one is an Arduino microcontroller that performs as an I/O interface for the PC. Each motor steering wheel (L, left and R, right) has a powerful motor, controlled in PWM, to manage the wheel rotation speed $\omega_{R/L}$ and a second motor connected to the steering subsystem to manage the steering angle $\theta_{R/L}$. The motion command from the rider's movements that are obtained from cameras and IMU. These signals are elaborated from the PC and become the platform motion planar speeds v_x , v_y and ω .

The mobility platform requirements are related to hand-free wheelchair tasks. The developed mobility platform is shown in Fig. 2 and it is composed of two motor steering wheels and a passive

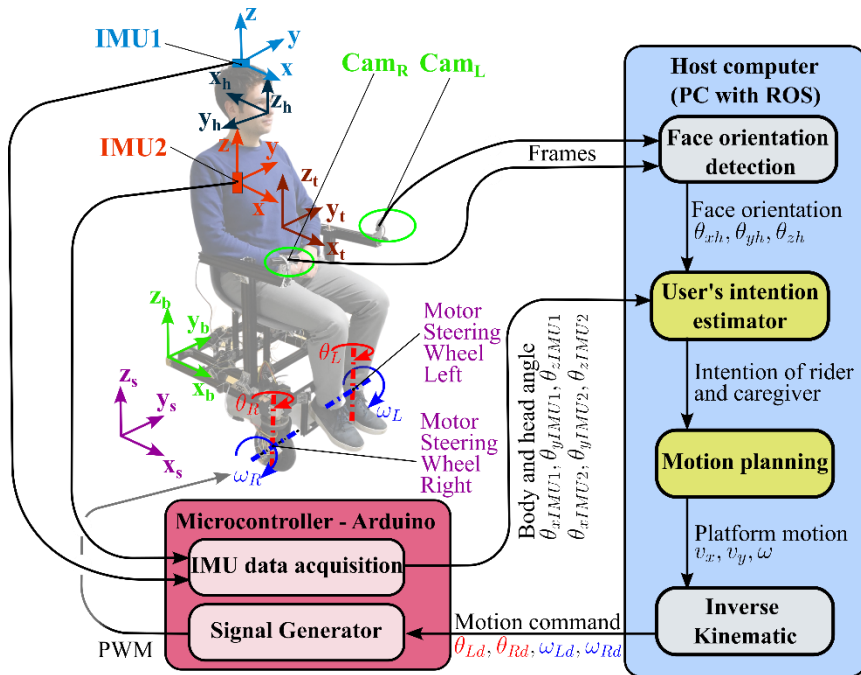

Fig. 1 Hand-free wheelchair working principle.

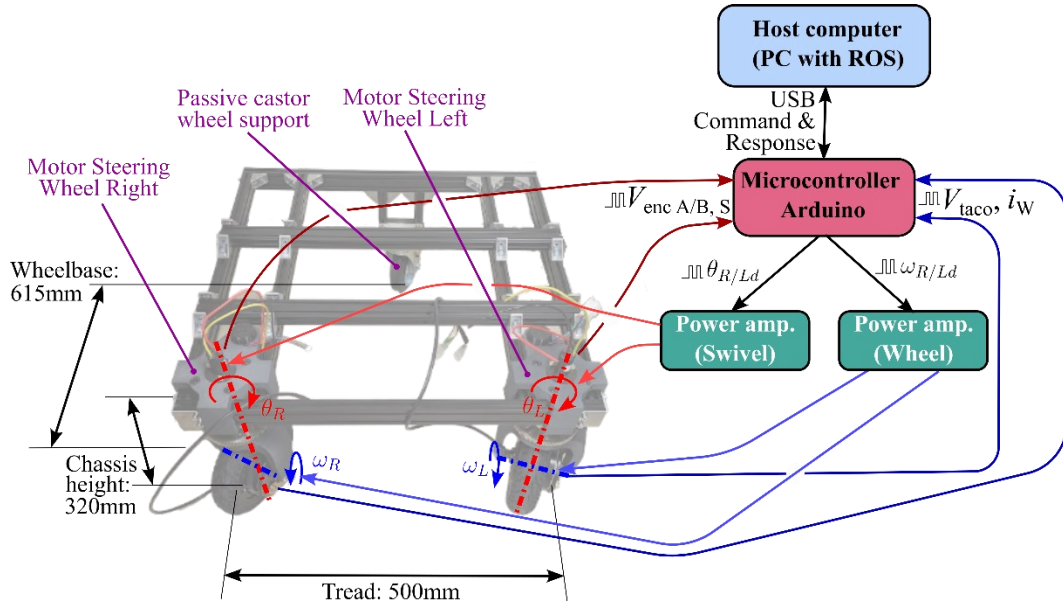

Fig. 2 Composition, dimension and functioning of the mobility platform.

caster wheel. It receives the three planar speeds and through the inverse kinematic module inside the PC generates the four different inputs for the motor steering wheels, θ_{Ld} , θ_{Rd} , ω_{Ld} and ω_{Rd} . Where θ_{Ld} and θ_{Rd} represent the two rotations of the swivel axis while ω_{Ld} and ω_{Rd} are the two speeds of the traction motors. The wheelchair requires high maneuverability in narrow indoor environments because it should be as similar as possible to the human movement range. For that reason, the mobility platform has all three planar speeds and small overall dimensions.

3. Platform development

3.1 The Wheelchair platform

This section details the components, dimensions and function of the omnidirectional platform that composes a hand-free wheelchair. The overall dimensions of the platform are 615x615x320 mm, as written in Fig. 2, and between the two motor steering wheels there is a thread of 500mm. These dimensions respect the limits imposed by ISO for wheelchair dimensions of 1200x700 mm [11], especially for the width. The thread dimension is chosen to be bigger than the chair dimension but also more compact as possible. The diameters of the wheels are 200 mm for the active and 150 mm for the passive, which results in the biggest part out of the 320 mm of platform height, the additional 120 mm hosts the fork, the bearing and the chassis support. These characteristics lead to a reduction of inertia and an increase in agility and maneuverability.

The chassis of the platform is composed of aluminum frames to be lighter and presents a square shape because is the simpler and more rigid shape to build. In the chassis, some additional inner aluminum frames are present to increase the rigidity and to fasten components including a seat for a rider such as sensors, microcontrollers, PC and future devices to extend the functionality, in customizable positions. The bigger aluminum frames as a section of 40x20 mm, while the smaller ones are only 20x20 mm and they are all linked to each other with iron support to increase rigidity and robustness.

The motor wheel module is composed of an in-wheel Brushless 24 V DC (BLDC) motor that can express a mechanical power of 300 W and it is used for traction. The swivel motor is a 12 V DC motor with a mechanical power of 18 W, and it presents a built-in encoder and a planetary reducer with a gear ratio of 1:264, this guarantees precision but also additional power loss and for this reason is used for steering function.

Fig. 2 also details the PWM signals that are exchanged between the microcontroller and the signal generator of the power amplifier. From the motor point of view, they receive a voltage and a current proportional to the PWM signal. The motor's feedback is a PWM signal that is read directly from the microcontroller, it gives the rotation speed of the traction motor and the position of the swivel motor. Thanks to the feedback the microcontroller can close the command loop and have a more accurate control.

3.2 The motor steering wheel design

This is the most important module of the platform because it provides the motion and also supports an important part of the weight of the platform. As detailed in Fig. 3, it is composed of 11 components that are summarized in Table 1.

Table 1 Components of the motor steering wheel

N°	Component name	N°	Component name
1	Swivel DC motor with encoder	7	Bearing support
2	Traction BLDC motor	8	Steering shaft
3	Fork	9	Spur gear Mecha Lock
4	Pinion gear	10	Pinion gear Mecha Lock
5	Spur gear	11	Slip ring
6	Support frame		

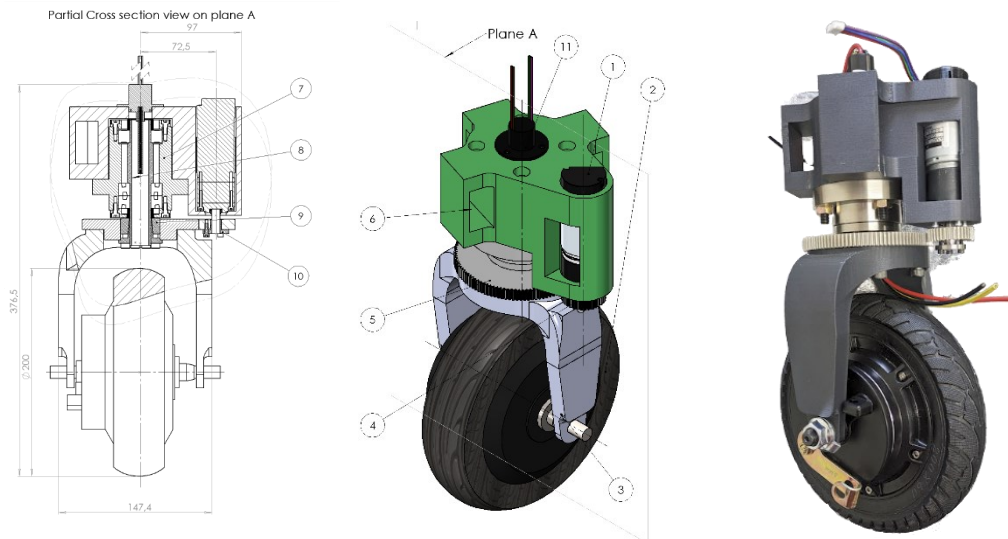

Fig. 3 Design of the motor steering wheel module (L, M) and developed prototype (R).

The Traction BLDC motor is inside the wheel mounted on a steering axle through a fork. A spur gear, having 110 teeth and a module of 1mm, is fixed on the steering axle by a “Mecha Lock” so that it meshes with a pinion gear. The pinion gear having 35 teeth, again is fixed to a driving shaft of a Swivel DC motor by a “Mecha Lock”. The driving system of the steering axle thus has a gear ratio of 3.14. The bearing support and the support frame are the components that link the chassis of the platform to the steering axle. The bearing support holds two angular bearings, in the bottom part, and a radial bearing above. They are useful for supporting the weight load while permitting the rotation of the steering axle itself. The last component, the slip ring, is useful to permit infinite rotation of the axle while establishing electric conductivity to the traction motor.

Most of the components are acquired from the commercial market and assembled, but the fork and the support frame need to be specifically designed for our purpose and are 3D manufactured. The support frame presents three rectangular holes that can hold the aluminum frames, to support the platform. It has also a cylindrical hole to hold the correct position of the swivel motors. Finally, the support frame has some screw holes to fasten the swivel motors and the bearing support.

The fork is a simpler component because it only requires a set of four screw holes to fasten with the spur gear in addition to a central hole that houses the gear itself and lets pass the cable from the slip ring to the BLDC motor. The fork is the most stressed component because in its arms, all the weight passes from the chassis to the wheel and then to the ground. Typically, the vertical force that each wheel has to support is around 400 N, if the generated weight force by the platform with rider, microcontroller and other equipment is 12000 N and is roughly distributed to the three wheels. Moreover, that could be some tangential force due to the dynamic of the platform to be considered. For this reason, the worst scenario that the fork should face was investigated through a FEM analysis. Fig. 4 shows the forces considered in this case, they simulate an overload condition of 800 N of weight force and 150 N of tangential force for each fork’s arm. The results of this overloading configuration are encouraging because they present a safety higher than 6 except for some very small zones that are in contact with the BLDC motor shaft. According to their position and their dimension, the Hertzian contact theory is most appropriate for describing the stress concentration, so the FEM results can be ignored because not enough representative.

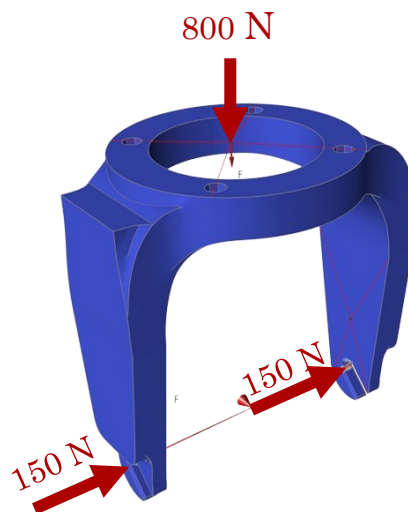

Fig. 4 FEM analysis of the fork stress concentration in the worst

4. Motion control experiment

The platform motion capabilities are tested through two simple cases, one requires a frontal movement, and the other requires a lateral movement. The platform demonstrates the capability to maintain the same trajectory, and not suffer disturbances bound to the backlash of all the assembled parts. Moreover, it demonstrates also good stability because the center of mass is symmetrical to the lateral frames, but more shifted to the frontal frames and so, above the traction motors. Fig. 5a details the equipment used for the experiment: a DC supply to give power to the motors and the power amplifiers, a microcontroller to generate the driving signal and receive the feedback and a PC only for monitoring purposes. Fig. 5b and Fig. 5c show respectively the lateral and the forward and backward tests. In this and following tests, an open-loop basis was taken, namely, a constant PWM duty was given to the motor drivers of traction wheels among a pre-determined time window while holding the steering axles in an initial configuration. Both were successful tests, in which the trajectory was maintained easily and without divergences, even under the open-loop basis.

Another test is conducted to acquire experimental data and Fig. 6 shows the results. This test investigates three different movements, in 0° , 45° and 90° directions. In the first two, the orientation angle divergence was less than 5 degrees during the movement. In the 90° traveling case, there are more rotation effects possibly because of the imperfect alignment of the wheel which easily describes a circumference. The same errors due to the open-loop behavior are present in the velocity value. In fact, despite the PWM signal given is always the same, the reached velocity was different because of the dynamic and inertia effects of the platform, in such a way that the acceleration in the 0° case is suddenly decreases, in the other two cases is more constant. For that reason, the difference in distance traveled is related to the difference in velocity reached and time duration.



(a) Overview of the setup



(b) Lateral movement.



(c) Forward and backward movement.

Fig. 5 Platform motion control experiment.

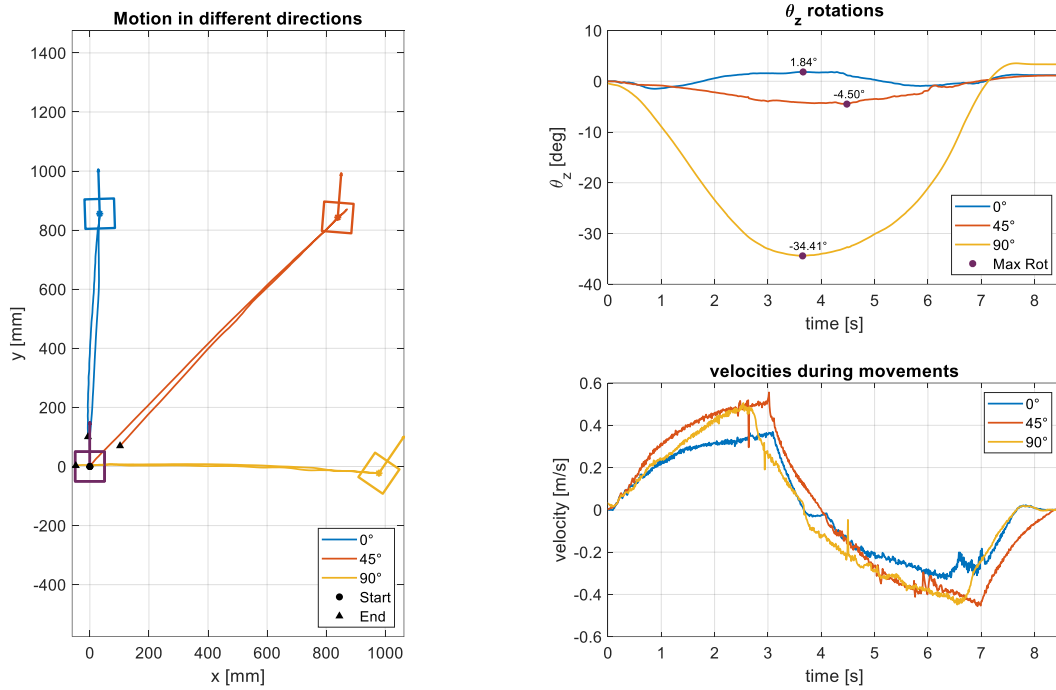

Fig. 6 Experimental data acquired: position, rotation and velocities in each case.

5. Conclusion

Summing up the obtained results, the mobility platform successfully achieved in the experimental test:

- The load test highlights that the structure is well-dimensioned and enough robust to hold the rider's weight;
- The moving test shows the ability of the system to navigate in a narrow environment, using all the possible directions, like people when walking. It is also a good benchmark test to see the driving performance of motors and drivers.
- The open-loop control is enough to demonstrate the feasibility of the movements, but it should be improved with a closed-loop control to achieve better and more reliable results.

The most suitable improvements are doing more dynamic tests, such as roto-translation and or overweight tests, this helps also to develop the closed-loop controller. Moreover, try to drive the platform with the HMI described in the introduction section.

Acknowledgment

This publication is part of the project PNRR-NGEU which has received funding from the MUR – DM 351/2022 and has been supported by a joint research contract between JTEKT Corporation and Tokyo Institute of Technology.

References

- [1] “Persons with Disabilities - Employment, Social Affairs & Inclusion - European Commission.” Retrieved 26 February 2024. <https://ec.europa.eu/social/main.jsp?catId=1137>
- [2] Fehr, L., Langbein, W. E., and Skaar, S. B., “Adequacy of Power Wheelchair Control Interfaces for Persons with Severe Disabilities: A Clinical Survey,” Vol. Fehr, Linda, W. Edwin Langbein, and Steven B. Skaar. “Adequacy of power wheelchair control interfaces for persons with severe disabilities: A clinical survey.” *Journal of rehabilitation research and development*, 2000.
- [3] Tagliavini, L., and Quaglia, G., “On the Design of MoviWE.Q: An Omnidirectional Electric-Powered Wheelchair for Indoor Mobility,” Cham, 2023. https://doi.org/10.1007/978-3-031-45770-8_31
- [4] Iturrate, I., Antelis, J., and Minguez, J., “Synchronous EEG Brain-Actuated Wheelchair with Automated Navigation,” presented at the 2009 IEEE International Conference on Robotics and Automation, 2009. <https://doi.org/10.1109/ROBOT.2009.5152580>
- [5] Pacnik, G., Benkic, K., and Brecko, B., “Voice Operated Intelligent Wheelchair - VOIC,” In *Proceedings of the IEEE International Symposium on Industrial Electronics, 2005. ISIE 2005.*, Vol. 3, 2005, pp. 1221–1226 vol. 3. <https://doi.org/10.1109/ISIE.2005.1529099>
- [6] Manawadu, U. E., Kamezaki, M., Ishikawa, M., Kawano, T., and Sugano, S., “A Hand Gesture Based Driver-Vehicle Interface to Control Lateral and Longitudinal Motions of an Autonomous Vehicle,” presented at the 2016 IEEE International Conference on Systems, Man, and Cybernetics (SMC), 2016. <https://doi.org/10.1109/SMC.2016.7844497>
- [7] Matsumoto, Y., Ino, T., and Ogasawara, T., “Development of Intelligent Wheelchair System with Face and Gaze Based Interface,” presented at the Proceedings 10th IEEE International Workshop on Robot and Human Interactive Communication. ROMAN 2001 (Cat. No.01TH8591), 2001. <https://doi.org/10.1109/ROMAN.2001.981912>
- [8] Matsuura, D., Kiyomoto, K., and Kobayashi, T., “Development of a Simple Human-Cooperative Transportation System Based on Tactile Information,” Vol. Proceedings of the 19th International Conference on Precision Engineering.
- [9] Mougharbel, I., El-Hajj, R., Ghamlouch, H., and Monacelli, E., “Comparative Study on Different Adaptation Approaches Concerning a Sip and Puff Controller for a Powered Wheelchair,” presented at the 2013 Science and Information Conference, 2013.
- [10] Lund, M. E., Christensen, H. V., Caltenco, H. A., Lontis, E. R., Bentsen, B., and Andreasen Struijk, L. N. S., “Inductive Tongue Control of Powered Wheelchairs,” presented at the 2010 Annual International Conference of the IEEE Engineering in Medicine and Biology, 2010. <https://doi.org/10.1109/IEMBS.2010.5627923>
- [11] 14:00-17:00, “ISO 7193:1985,” ISO. Retrieved 4 April 2024. <https://www.iso.org/standard/13810.html>