

Experimental Study of RC Frames with Window and Door Openings Under Cyclic Loading

Original

Experimental Study of RC Frames with Window and Door Openings Under Cyclic Loading / Khan, N. A.; Zhou, L.; Di Trapani, F.; Demartino, C.; Monti, G.. - 236:(2023), pp. 293-303. (2nd International Workshop on Energy-Based Seismic Engineering, IWEBSE 2023 Porto (Portugal) July 3-6 2023) [10.1007/978-3-031-36562-1_23].

Availability:

This version is available at: 11583/2987870 since: 2024-04-17T06:13:37Z

Publisher:

Springer Science and Business Media Deutschland GmbH

Published

DOI:10.1007/978-3-031-36562-1_23

Terms of use:

This article is made available under terms and conditions as specified in the corresponding bibliographic description in the repository

Publisher copyright

Springer postprint/Author's Accepted Manuscript

This version of the article has been accepted for publication, after peer review (when applicable) and is subject to Springer Nature's AM terms of use, but is not the Version of Record and does not reflect post-acceptance improvements, or any corrections. The Version of Record is available online at: http://dx.doi.org/10.1007/978-3-031-36562-1_23

(Article begins on next page)

Experimental study of RC Frames with window and door openings under cyclic loading

Nisar Ali Khan^{1,2}[0000-0002-4765-2773], Lin Zhou³[0000-0002-6018-4927],
Fabio Di Trapani⁴[0000-0002-7578-0633], Cristoforo Demartino^{5,6}[0000-0002-9364-5160] and
Giorgio Monti⁷[0000-0002-5673-5706]

¹ Department of Architecture, University Roma Tre, Largo Giovanni Battista Marzi, 10, 00153 Roma, Italy

² Department of Civil Engineering, Faculty of Engineering & Technology, International Islamic University, Sector H-10, Islamabad 44000, Pakistan

³ College of Civil Engineering and Architecture, Zhejiang University, Hangzhou, China
linzhou1990@zju.edu.cn

⁴ Politecnico di Torino, Dipartimento di Ingegneria Strutturale Edile e Geotecnica, Corso Duca degli Abruzzi 24, 10129, Turin, Italy

⁵ Zhejiang University- University of Illinois at Urbana Champaign Institute, Zhejiang University, Haining, Zhejiang, China

⁶ Department of Civil and Environmental Engineering, University of Illinois at Urbana-Champaign, Urbana, IL 61801, USA

⁷ Sapienza Università di Roma, Dipartimento di Ingegneria Strutturale e Geotecnica, Rome, Italy

Abstract: This paper aims to experimentally investigate the effect of different types of openings on the cyclic response of masonry infilled reinforced concrete frames. Six 2/3-scale square specimens, consisting of bare frame, fully infilled walls, and walls with door or window openings arranged with hollow clay bricks were tested under quasi-static lateral cyclic loading up to large drifts. The experimental responses were analyzed in terms of strength, stiffness, ductility, energy dissipation, equivalent damping and damage mechanisms and compared against those observed in the reference bare frame and fully infilled frame. Results indicated that the typology of the openings significantly alter the resisting mechanisms, although without substantial modification to the lateral resistance capacity. Furthermore, the limit state thresholds were shown to be achieved at substantially different inter-storey drifts, suggesting differing damage metrics.

Keywords: Infilled RC Frames, Openings, Masonry, Experimental testing, Energy dissipation, Cyclic response

1 Introduction

The vital role played by masonry infills in determining the seismic performance of reinforced concrete (RC) frame structures has been the subject of extensive research through post-earthquake damage observations. Reflecting this, numerous researchers have conducted comprehensive experimental studies in this area over the last 50

years. The field of RC frames with solid infills has seen numerous valuable experimental campaigns, including those by [1-10]. These studies have made a significant contribution to the understanding of the behavior of RC frames with solid infills under seismic loading. However, tests conducted on infilled frames with openings are considerably fewer than those carried out on solid ones [11]. Among these tests, [12-14] investigated one-storey steel-infilled frames, while most of the experimental studies concentrated on RC infilled frames [15-25]. Moreover, [26-28] tested full-scale reinforced concrete multi-storey frames that included both solid infills and infills with openings. Based on the experimental test results, various authors have proposed empirical relationships to modify the equivalent strut approach to account for the reduction in strength and stiffness caused by the presence of openings. However, most existing empirical relationships only consider the opening area as an input parameter and do not account for the effect of opening typology on the seismic response of infilled frames. This simplified assumption is due to the limited knowledge of underlying damage mechanisms. Thus, further research is needed to develop more comprehensive models that take into consideration these factors. To achieve this, a more thorough understanding of the damage mechanisms related to infilled frames is crucial.

The study involved comparing the cyclic responses of infilled frames with openings to those of the bare frame and the specimens with solid infills, based on strength, stiffness, ductility, energy dissipation, equivalent damping and damage mechanisms. The aim was to gain a better understanding of how the mechanical response of infilled frames with window and door openings is modified, focusing on overall response parameters and damage mechanisms that are activated based on the typology of the openings within the infill.

2 Experimental program

2.1 Specimen details

In the experimental program, eight 2/3 scaled specimens were tested using a cyclic loading protocol. The specimens tested in this study included a bare frame, a fully infilled frame, and six infilled frames with openings. The latter were classified into three types: central window openings (CW), side window openings (SW), and central door openings (CD). Two replicas of each type, identified as F1 and F2, were arranged. Geometric details of specimens shown in Fig. 1.

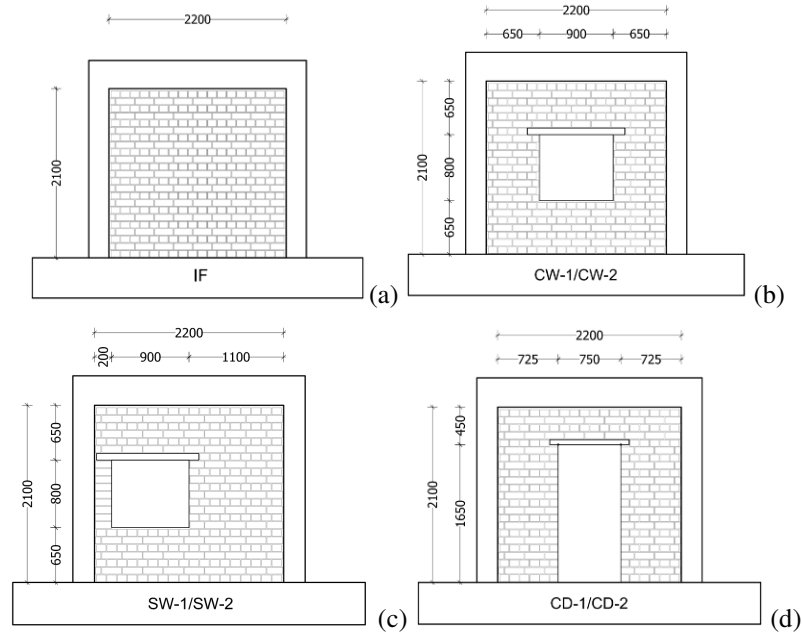

Fig. 1. Geometric details of specimens: (a) IF; (b) CW; (c) SW; (d) CD. Dimensions in mm.

The infills consisted of two wythes of hollow clay masonry bricks (Fig. 2). The mortar courses were approximately 10 mm thick. The RC frame used in all tests had geometrical and reinforcement details shown in Fig. 2.

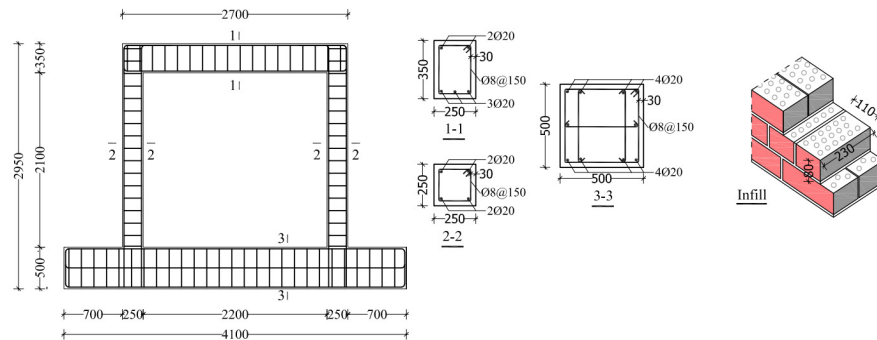

Fig. 2. Reinforcement details of the frame and arrangement of the masonry (dimensions in mm).

2.2 Material properties

Comprehensive material testing was conducted, which included compressive tests on 150x150x150 mm concrete cubes and 50x50x50 mm mortar cubes, tensile tests on steel rebars, and compressive tests on bricks with a 20% opening percentage. The

compressive tests on the bricks were carried out in the direction parallel to the holes. Table 1 present the results of these tests.

Table 1. Mechanical properties of materials.

Specimen	Concrete	Steel		Brick	Mortar
	(Compr. strength) f_c (MPa)	(Tensile strength) f_y (MPa) f_t (MPa)		(Compr. strength) f_b (MPa)	(Compr. strength) f_{mr} (MPa)
#1	13.78	441	638	10.5	5.0
#2	13.95	438	618	11.6	2.6
#3	13.33	431	668	12	3.4
#4	13.87	420	202	8.7	3.4
#5	13.65	491	616	13.2	4.4
#6	12.62	428	585	12.2	1.6
#7				26.9	3.8
#8				14.4	3.6
#9				14.6	2.3
#10				20.2	2.2
#11					2.5
#12					4.2
Mean	13.53	441.50	554.5	14.43	3.25
Std. Dev.	0.50	25.37	174.8	5.35	1.02
COV	4%	6%	32%	37%	31%

2.3 Masonry properties

Masonry prisms measuring 900x750x230 mm were subjected to compression tests along the direction of the holes in the bricks, which is perpendicular to the mortar bed joints. The average compressive strength of the masonry specimens (f_{mm}) was found to be 3.36 MPa, and the average elastic Young's modulus (E_m) was 3730 MPa. Diagonal shear tests were also conducted on masonry wall specimens with dimensions of 620 x 620 x 230 mm, an average shear resistance in the absence of compressive loads ($f_{vm}=0.356$ MPa) and an average shear modulus ($G_m=318.8$ MPa).

2.4 Test setup and instrumentation

All specimens were tested at the structural laboratory of Zhejiang Technical University in Hangzhou, China. A pictures of a specimen in the testing apparatus is shown in Fig. 3. The horizontal lateral load was applied to the mid-height of the beam using a double-action hydraulic actuator connected to the reaction wall and hinged to the steel beam. The hydraulic jack had a stroke of ± 250 mm and a nominal load capacity of ± 2000 kN. To transfer the horizontal force to the frame during reverse loading cycles, a system comprising two steel plates and eight prestressed rebars was employed on the steel beam. Furthermore, the vertical load was constant and equally distributed between the two columns (195 kN per column) via two independent hydraulic jacks, corresponding to an axial load ratio of 0.2. The distribution of the vertical load to the columns was facilitated through two steel plates that enabled replication of the effects of gravity loads.



Fig. 3. Test setup and instrumentation.

Each specimen underwent a cyclic displacement protocol consisting of 30 cycles, with each cycle repeated three times for every target displacement level. The testing procedure for displacements is beginning at ± 10 mm and increasing by increments of 10 mm after completing each set of three cycles until reaching a maximum displacement level of 100 mm. This resulted in interstorey drift ranges from 0.47% to 4.7%. During all tests, measurements were taken for lateral force versus top displacement (mid-height of the RC frame beam) response while following the same testing protocol.

3 Experimental results

The study compared and analyzed the results in terms of strength, stiffness, ductility, energy dissipation, equivalent damping and damage mechanisms. Specifically, the investigation focused on how opening typology influenced the response of the specimens, with a particular emphasis on comparing them to bare frame and fully infilled frame cases. The cyclic responses of all specimens are depicted in Fig. 4, while the damage patterns in correspondence of the peak load are shown in Fig. 5. Detailed interpretation of these outcomes is provided in subsequent sections for better understanding.

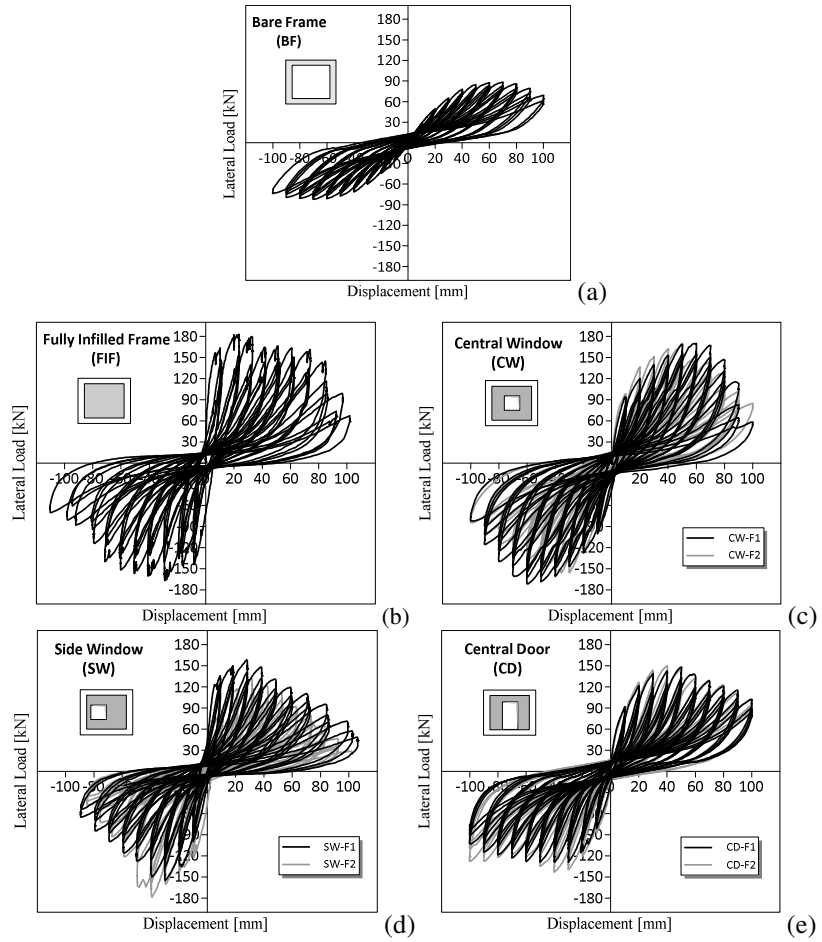

Fig. 4. Cyclic responses of the specimens: (a) Bare frame (BF); (b) Fully infilled frame (FIF); (c) Central window (CW); (d) Side window (SW); (e) Central door (CD).

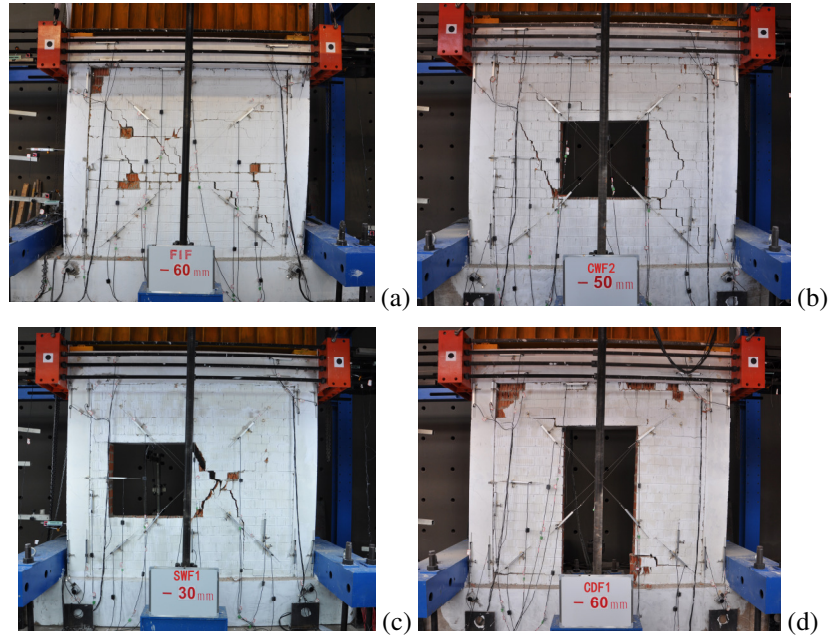

Fig. 5. Damage patterns of the specimens at the peak load: (a) Fully infilled frame (FIF); (b) Central window (CW); (c) Side window (SW); (d) Central door (CD).

3.1 Strength, stiffness, ductility

Fig. 6 shows the backbone curves of the different specimens, displaying their strength and stiffness more clearly. The initial stiffness (K_0) was determined by calculating the slope of the line connecting the origin to the point where the first change in slope occurs, indicating the initial cracking stage. Table 2 summarizes the initial stiffness values for each specimen, along with the ratios of these values for infilled frames compared to bare frames (K_0/K_{B0}) and for infilled frames with openings compared to fully infilled frames ($K_0/K_{FI,0}$). The fully infilled frame had a significantly higher initial stiffness (about 21 times) than the bare frame, while the presence of openings reduced this initial stiffness by about 70% compared to the fully infilled frame. Despite variations in opening typology, the initial stiffness of infilled frames with openings remained similar, averaging 27% of the fully infilled frame's initial stiffness (as shown in Table 2).

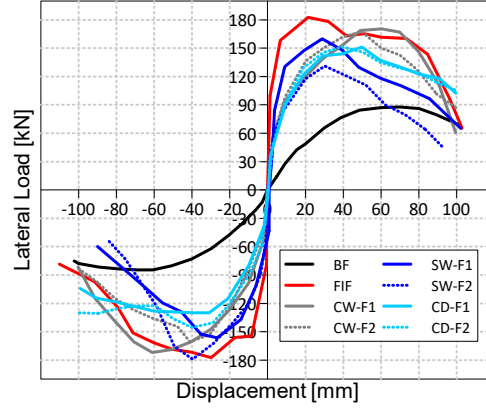

Fig. 5. Backbone curves: positive and negative envelopes.

Table 2. Initial stiffness and initial stiffness ratios of the specimens.

Specimen	K_0 (kN/mm)	$K_0/K_{B,0}$ (-)	K_0/K_{FI} (-)
BF	3.3	-	-
FIF	70.8	21.25	1.00
CW-F1/2	17.6	5.28	0.25
SW-F1/2	21.0	6.30	0.30
DW-F1/2	19.6	5.87	0.28

Table 3 reports the peak resistances (R_{peak}), displacements (d_{peak}), interstorey drifts ($d_{r,peak}$); ultimate resistances (R_{ult}), displacements (d_{ult}) and interstorey drifts ($d_{r,ult}$) of the specimens. Several considerations can be drawn from the experimental data. Firstly, infilled frames with openings may develop alternative mechanisms to resist loading and achieve peak resistances comparable to fully infilled frames. Secondly, the peak and ultimate drifts of infilled frames with openings vary significantly depending on the opening typology. Central openings shift the peak and ultimate drifts relative to fully infilled frames, with central door opening specimens showing a ductile behavior.

Table 3. Peak and ultimate resistances and displacements of the specimens.

Specimen	$R_{peak}/$		$d_{peak}/$			$d_{ult}/$			
	R_{peak} (kN)	$R_{B,peak}$ (-)	d_{peak} (mm)	$d_{r,peak}$ (%)	$d_{B,peak}$ (-)	R_{ult} (kN)	d_{ult} (mm)	$d_{r,ult}$ (%)	$d_{B,ult}$ (-)
BF	86	1.00	60.0	2.86%	1.00	73.1	100	4.76%	1.00
FIF	178	2.07	31.0	1.48%	0.52	151.3	73	3.48%	0.73
CW-F1/2	163	1.90	49.0	2.33%	0.82	138.6	76	3.62%	0.76
SW-F1/2	152	1.77	28.0	1.33%	0.47	129.2	51	2.43%	0.51
DW-F1/2	142	1.65	40.0	1.90%	0.67	120.7	90	4.29%	0.90

3.2 Energy dissipation and equivalent damping

The assessment of energy dissipation involved the evaluation of various energy-related parameters, including the energy dissipation per cycle (W_d), the cumulative energy dissipation (ΣW_d), and the average energy dissipation per unit length ($W_d/2\delta$). The latter was determined by dividing the energy dissipation per cycle by the total peak-to-peak displacement variation for each cycle (2δ). The results are presented in Fig. 6. The infilled frame specimens exhibited significantly higher energy dissipation than the bare frame at each cycle (Fig. 6a), regardless of the presence of openings. Each displacement level consists of three cycles and as the number of cycles increases, the energy dissipation in cycles with the same displacement decreases, indicating a degradation of the mechanical behavior (Fig. 4, Fig. 6a). Different energy dissipation trends were observed across the various cases. The fully infilled frame demonstrated the highest average dissipation up to 1.5% interstorey drift, but decreased rapidly up to 0.5% drift (Fig. 6b). Beyond 2.0% drift, $W_d/2\delta$ stabilized at a constant value. Infilled frame specimens with central window (CW) and door openings (CD) displayed a more stable trend. For these specimens, the average energy dissipation per unit length was initially significantly lower than the FI specimen, but it remained constant from 1 to 3.5% drift. In this range, the CW specimen exhibited approximately double the energy dissipation capacity of the CD specimen. A different response was recognized from the specimen with the eccentric window (SW). The latter had a similar energy dissipation capacity to the CW specimen up to 1.5% drift (Fig. 15b). Beyond this point, the energy dissipation constantly decreased. This is also evident in terms of cumulative energy dissipation (Fig. 6c). It is also noteworthy that beyond 1.5% drift, the CW specimen dissipated more energy than the FIF (Fig. 6b). It can be generally noted that specimens with higher stiffness (FI), and therefore subjected to earlier damage, exhibited higher energy dissipation at lower drifts, which was reduced when the displacement demand increased. Conversely, specimens with lower initial stiffness (CW and CD) exhibited a stable energy dissipation capacity, which was maintained even in response to high drift demands.

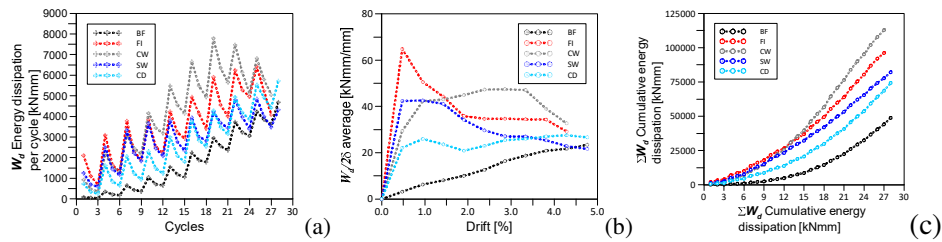

Fig. 6. Energy dissipation: (a) Energy dissipation per cycle; (b) Average energy dissipation per unit length. (c) Cumulative energy dissipation.

The equivalent viscous damping (ξ_{eq}) at the different cycles was also evaluated as Eq. (1):

$$\xi_{eq} = \frac{W_d}{2\pi(|W_e^+| + |W_e^-|)} \quad (1)$$

where W_d is the dissipated energy per cycle, and W_e^+ and W_e^- are the elastic energy at the positive and negative peak displacements, respectively. Fig. 7 show that the infilled frame behaved differently from the bare frame: while the bare frame had a steady increase between 2% and 6% drifts (Fig. 7b), the infilled frame showed a trend characterized by a decrease up to 2%-2.5% drifts, followed by an increase at higher drift levels. For the FI, CW and SW specimens, the average values of ξ_{eq} were relatively similar, primarily falling between 3.8% and 6%, while the BF and CD specimens had lower values in the range of 2.5-4.5%.

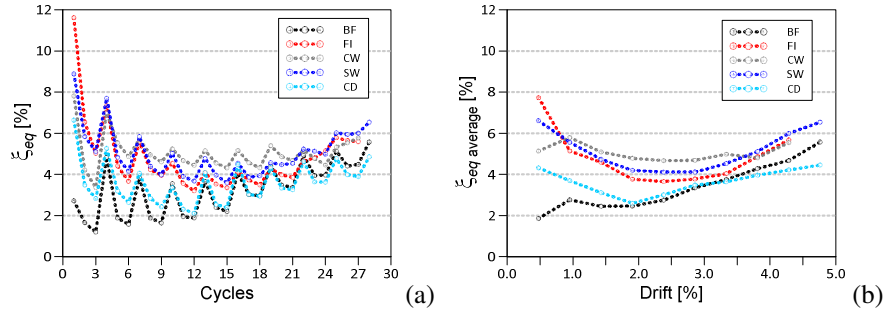

Fig. 7. Equivalent viscous damping: (a) equivalent viscous damping per cycle; (b) average equivalent viscous damping at the different drifts.

4 Conclusions

In this study, eight 2/3 scale infilled frames constructed with hollow clay brick masonry and one bare frame were experimentally investigated under quasi-static cyclic lateral loading. The specimens included solid infills as well as those with central door and window openings. The paper analyzed the effect of opening typology on strength, stiffness, ductility, energy dissipation, equivalent damping and damage mechanisms. Based on the comprehensive findings, the following conclusions can be drawn:

- The existence of openings in masonry infills substantially alters the overall response compared to fully infilled frames. Nonetheless, a strong interaction between the infill and frame persists due to the emergence of alternative resisting mechanisms.
- The tested infilled frames with openings exhibited a lower initial stiffness (-70%) compared to fully infilled frames. However, the initial stiffness of infilled frames with openings was still six times greater than that of bare frames.
- The peak resistance of the tested infilled frames with the considered opening ratios did not exhibit significant reductions when compared to the fully infilled frame case.

- The presence of openings substantially affected both the peak and ultimate drifts. Specimens with central openings, CW and DW, displayed a shift in peak drifts of +58% and +29%, respectively, whereas their ultimate drifts were similar to that of the fully infilled frame.
- All infilled frame specimens, displayed a substantially greater energy dissipation capacity compared to the bare frame. Infilled frames with central openings exhibited a consistent dissipation capacity, even when subjected to significant drift.

References

1. Mehrabi, A.B., Shing, P.B., Schuller M.P., Noland, L.: Experimental Evaluation of Masonry-Infilled RC Frames. *J Struct Eng (ASCE)* 122(3):228-237 (1996).
2. Calvi, G.M., Bolognini, D.: Seismic response of reinforced concrete frames infilled with weakly reinforced masonry panels. *J Earthq Eng* 5(02):153-85 (2001).
3. Al-Chaar, G., Issa M, Sweeney, S.: Behavior of Masonry-Infilled Nonductile Reinforced Concrete Frames. *J Struct Eng*, 128:1055-1063 (2002).
4. Papia M, Cavaleri L, Fossetti M. Infilled frames: developments in the evaluation of the stiffening effect of infills. *Structural engineering and mechanics* 16(6): 675-93 (2003).
5. Colangelo F.: Pseudo-dynamic seismic response of reinforced concrete frames infilled with non-structural brick masonry. *Earthq Eng Struct Dyn* 34:1219-1241 (2005).
6. da Porto F, Guidi M, Dalla Benetta N, Verlato F. Combined in-plane/out-of-plane experimental behaviour of reinforced and strengthened infill masonry walls. 12th Canadian Masonry Symposium, June 2-5, Vancouver, Canada (2013).
7. Cavaleri L, Di Trapani F. Cyclic response of masonry infilled RC frames: Experimental results and simplified modeling. *Soil Dyn Earthq Eng* 65:224-242 (2014).
8. Bergami, A., and C. Nuti. 2015. Experimental tests and global modeling of masonry infilled frames. *Earthquake Struct.* 9 (2): 281-303.
9. Verderame GM, Ricci P, Del Gaudio C, De Risi MT.: Experimental tests on masonry infilled gravity- and seismic-load designed RC frames. In: 16th international brick and block masonry conference, IBMAC 2016; 2016. p. 1349-58
10. Morandi P, Hak S, Magenes G. In-plane Experimental Response of Strong Masonry In-fills. *Eng Struct* 156:503-521 (2018).
11. Mohammadi M, Nikfar F. Strength and Stiffness of Masonry-Infilled Frames with Central Openings Based on Experimental Results. *J. Struct. Eng.* 2013.139:974-984.
12. Dawe, J. L., and Seah, C. K.. Behaviour of masonry infilled steel frames. *Can. J. Civ. Eng.*, 16(6), 865-876 (1989).
13. Mosalam, K. M., White, R. N., and Gergely, P.: Static response of infilled frames using quasi-static experimentation. *J. Struct. Eng.*, 123(11), 1462-1469 (1997).
14. Tasnimi, A. A., and Mohebkah, A.: Investigation on the behavior of brick-infilled steel frames with openings, experimental and analytical approaches. *Eng. Struct.*, 33(3), 968-980 (2011).
15. Kakaletsis, D. J., and Karayannis, C. G.: Experimental investigation of infilled R/C frames with eccentric openings. *Struct. Eng. Mech.*, 26(3), 231-250 (2007).
16. Kakaletsis, D. J., and Karayannis, C. G.: Influence of masonry strength and openings on infilled R/C frames under cycling loading.: *J. Earthquake Eng.*, 12(2), 197-221 (2008).
17. Kakaletsis, D. J., and Karayannis, C. G.: Experimental investigation of infilled reinforced concrete frames with openings. *ACI Struct. J.*, 106(2), 132-141 (2009).

18. Blackard B, Willam K, Mettupalayam S.: Experimental Observations of Masonry Infilled Reinforced Concrete Frames with Openings. ACI Symposium Paper 2009, 265:199-122.
19. Sigmund, V., and D. Penava.: Influence of openings, with and without confinement, on cyclic response of infilled R-C Frames-An experimental study.: J. Earthquake Eng. 18 (1): 113–146 (2014).
20. Zhai, C., J. Kong, X. Wang, and Z. Chen. Experimental and finite element analytical investigation of seismic behavior of full-scale masonry infilled RC frames.” J. Earthquake Eng. 20 (7): 1171–1198 (2016).
21. Mansouri, A., M. S. Marefat, and M. Khanmohammadi.: Experimental evaluation of seismic performance of low-shear strength masonry infills with openings in reinforced concrete frames with deficient seismic details.” Struct. Des. Tall Special Build. 23 (15): 1190–1210 (2014).
22. Morandi, P., S. Hak, and G. Magenes.: Performance-based interpretation of in-plane cyclic tests on RC frames with strong masonry infills.” Eng. Struct. 156 (Feb): 503–521 (2018).
23. Basha SH, Surendran S, Kaushik HB. Empirical Models for Lateral Stiffness and Strength of Masonry-Infilled RC Frames Considering the Influence of Openings J. Struct. Eng., 146(4): 04020021 (2020).
24. Di Trapani, F., Giordano, L, Mancini, G.: Progressive Collapse Response of Reinforced Concrete Frame Structures with Masonry Infills. Journal of Engineering Mechanics 146 (31), 04020002 (2020).
25. Di Trapani, F., Cavaleri, L., Ferrotto, M.F.: FE modeling of Partially Steel-Jacketed (PSJ) RC columns using CDP model. Computers and Concrete 22(2): 143 – 152 (2018).
26. Carvalho EC, Coelho E. Seismic assessment, strengthening and repair of structures. radECOEST2-ICONS report no. 2, European Commission - training and mobility of researchers programme (2001).
27. Al-Chaar G, Lamb GE, Issa M.: Effect of Openings on Structural Performance of Unreinforced Masonry Infilled Frames. ACI Symposium Paper 211: 247-262 (2003).
28. Stavridis A, Koutromanos I, Shing PB.: Shake-table tests of a three-story reinforced concrete frame with masonry infill walls. Earthquake Engng Struct. Dyn. (2011).