

Real time control developments at JET in preparation for deuterium-tritium operation

Original

Real time control developments at JET in preparation for deuterium-tritium operation / Lennholm, M.; Carvalho, I. S.; Cave-Ayland, K.; Chagnard, A.; Challis, C.; Felton, R.; Frigione, D.; Garzotti, L.; Goodyear, A.; Graves, J. P.; Guillemaut, C.; Harrison, J. R.; Lerche, E.; Lomas, P. J.; Mooney, R.; Rimini, F.; Sips, A. C. C.; Sozzi, C.; Subba, F.; Valcarcel, D.; Vega, J.. - In: FUSION ENGINEERING AND DESIGN. - ISSN 0920-3796. - 123:(2017), pp. 535-540.
[10.1016/j.fusengdes.2017.05.023]

Availability:

This version is available at: 11583/2986889 since: 2024-03-12T16:10:22Z

Publisher:

ELSEVIER SCIENCE SA

Published

DOI:10.1016/j.fusengdes.2017.05.023

Terms of use:

This article is made available under terms and conditions as specified in the corresponding bibliographic description in the repository

Publisher copyright

(Article begins on next page)

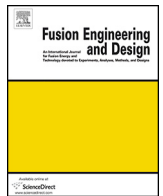

Real time control developments at JET in preparation for deuterium–tritium operation



M. Lennholm^{a,b,k,*}, I.S. Carvalho^{c,d,k}, K. Cave–Ayland^{d,k}, A. Chagnard^{e,k}, C. Challis^{d,k}, R. Felton^{d,k}, D. Frigione^{f,k}, L. Garzotti^{d,k}, A. Goodyear^{d,k}, J.P. Graves^{g,k}, C. Guillemaut^{c,d,k}, J.R. Harrison^{d,k}, E. Lerche^{d,h,k}, P.J. Lomas^{d,k}, R. Mooney^{d,k}, F. Rimini^{d,k}, A.C.C. Sips^{a,b,k}, C. Sozzi^{i,k}, D. Valcarcel^{d,k}, J. Vega^{j,k}, JET contributors¹

^a European Commission, B-1049 Brussels, Belgium

^b JET Exploitation Unit, Culham Science Centre, Abingdon OX14 3DB, UK

^c Instituto de Plasmas e Fusão Nuclear, Instituto Superior Técnico, Universidade de Lisboa, P-1049-001 Lisboa, Portugal

^d CCFE, Culham Science Centre, Abingdon OX14 3DB, UK

^e Ecole Centrale de Lille, 59651 Villeneuve d'Ascq, France

^f ENEA, C.R. Frascati, Roma, Italy

^g EPFL, CRPP, CH-1015 Lausanne, Switzerland

^h Laboratory for Plasma Physics, Koninklijke Militaire School, Ecole Royale Militaire Renaissancelaan, 30 Avenue de la Renaissance, B-1000 Brussels, Belgium

ⁱ Istituto di Fisica del Plasma, CNR, Milano, Italy

^j Laboratorio Nacional de Fusión, CIEMAT, Madrid, Spain, Spain

^k EUROfusion Consortium, JET, Culham Science Centre, Abingdon OX14 3DB, UK

HIGHLIGHTS

- Real time control schemes have been developed to optimise JET performance in DT with ITER like wall.
- Detachment control via impurity injection.
- ELM frequency control via gas/Pellet injection.
- Sawtooth pacing using ICRH.

ARTICLE INFO

Article history:

Received 29 September 2016

Received in revised form 3 February 2017

Accepted 5 May 2017

Available online 17 May 2017

Keywords:

Real time control
Tritium operation
Plasma termination
ELMs
Sawteeth
Detachment
Isotope control

ABSTRACT

Robust high performance plasma scenarios are being developed to exploit the unique capability of JET to operate with Tritium and Deuterium. In this context, real time control schemes are used to guide the plasma into the desired state and maintain it there. Other real time schemes detect undesirable behaviour and trigger appropriate actions to assure the best experimental results without unnecessary use of the limited neutron and Tritium budget. This paper discusses continuously active controllers and event/threshold detection algorithms triggering a variety of actions. Recent advances include: (i) Control of the degree of plasma detachment via impurity injection; (ii) ELM frequency control via gas/Pellet injection; (iii) Sawtooth pacing using ICRH modulation, (iv) control of the Hydrogen to Deuterium isotope ratio through gas injection and (v) the determination that a discharge is not evolving as desired, triggering a cascade of actions attempting to stop the plasma rapidly and safely, eventually triggering massive gas injection if a disruption is deemed unavoidable. For high power Deuterium–Tritium operation these control schemes need to be integrated into the plasma scenarios ensuring that they are mutually compatible.

© 2017 The Authors. Published by Elsevier B.V. This is an open access article under the CC BY-NC-ND license (<http://creativecommons.org/licenses/by-nc-nd/4.0/>).

1. Introduction

The JET tokamak is the only currently operating tokamak which can operate with the Deuterium–Tritium fuel mix required in a nuclear fusion reactor. The current JET plan envisages operation with pure Tritium (TT) plasma in 2018 followed by Deuterium–

* Corresponding author at: JET Exploitation Unit, Culham Science Centre, Abingdon OX14 3DB, UK.

E-mail address: morten.lennholm@jet.uk (M. Lennholm).

¹ See the Appendix of F. Romanelli et al., Proceedings of the 25th IAEA Fusion Energy Conference 2014, Saint Petersburg, Russia.

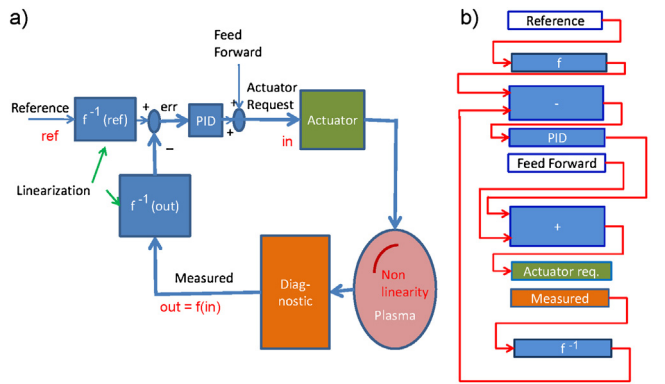

Fig. 1. (a) A simple closed loop algorithm with compensation for static nonlinearity. (b) Schematic illustration of the implementation of this controller in the RTCC language.

Tritium (DT) operation in 2019. Gaining further experience in operating a nuclear tokamak is considered essential for the success of ITER and the current and future JET programme is strongly focused on gathering the maximum information and experience from the upcoming TT and DT campaigns. The information sought encompasses the isotope scaling of H-mode threshold, confinement, ELM frequency etc. best gathered through TT experiments. The DT operation will provide valuable information on the physics of a plasma with significant alpha particle heating and neutron production. JET has undergone major changes since the previous DT experiments in 1997 [1], the most important of which is the installation of the all metal ITER like wall in 2010–11, using Beryllium as first wall material in the main chamber and Tungsten in the Divertor, as foreseen for ITER [2–4]. Operation with DT fuel and with the ITER like wall poses a series of specific challenges as described in Section 3. The current paper investigates the role that real time control can play in meeting these challenges.

2. JET real time control architecture

Two core control systems are required for the routine operation of the JET machine: The Plasma Position and Current Control system (PPCC) uses the poloidal coils as actuators while the plasma density feedback control system (PDF) uses gas injection as its actuator. Though these systems are not discussed further, it is understood that they are active together with all the controllers discussed. The controllers described in the following are running in a central controller (RTCC) which receives data, in real time, from a large number of JET measurement systems and real time processors [5]. RTCC can output request signals to various actuators, notably heating and gas introduction systems but also to PPCC and PDF. The programming of controllers in RTCC is done in a high level, block diagram language where each block in a standard block diagram is translated into a line in the programme. The user can program a control algorithm without having to worry about interface issues and as a consequence simple control algorithms can be implemented rapidly – even ‘on the fly’ during sessions.

Fig. 1a shows a simple single input single output (SISO) control scheme which is representative of a number of the controllers used at present at JET. The controller includes a nonlinear function which corrects for a known static nonlinearity in the input output map. The simple implementation in the RTCC high level language is shown schematically in Fig. 1b. For a robust implementation a few bells and whistles have to be added including things like limits and anti-windup.

Four separate control algorithms can run simultaneously within RTCC. Multi input multi output (MIMO) controllers with up to 3

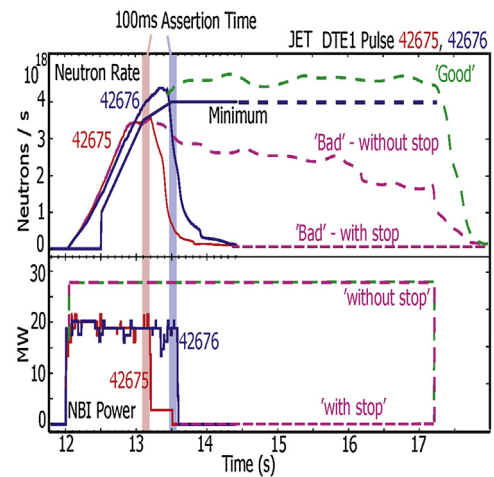

Fig. 2. ‘Dud’ detection. Two discharges from the 1997 JET Deuterium-Tritium experiments which were stopped when the neutron yield no longer exceeded the required minimum. The dashed lines sketch discharges planned for the next JET Deuterium-Tritium campaign.

inputs and 3 outputs have been implemented in a single algorithm and this is close to the current limit of the system capabilities. The possibility of upgrading the system to allow more complicated algorithms, while simplifying the interface for the operators, is under investigation.

3. Operational challenges and the role of real time control in meeting them

3.1. Tungsten influx

The dominant change associated with the installation of the ITER like wall on JET, already documented on ASDEX-Upgrade [6], is the tendency of tungsten to accumulate near the plasma centre [7,8]. Such accumulation can lead to a radiation collapse invariably causing a disruption. Several techniques have been developed to avoid or counter this accumulation. It turns out that ELMs, while sputtering tungsten from the divertor, also help to expel tungsten from the plasma edge. As a consequence a high ELM frequency can help limit impurity influx [9]. Once the tungsten has moved beyond the reach of the ELMs it moves towards the centre of the plasma. Here sawteeth are seen to expel tungsten effectively towards the outer part of the plasma [10,11]. A final tool, effective in preventing excessive tungsten accumulation, is central electron heating [12]. On JET such heating can be provided by ICRH, whereas ECRH has been shown to be effective on ASDEX-Upgrade. Effective avoidance of tungsten accumulation using these tools is readily achievable on JET, but a heavy price can be paid in terms of confinement if ELM and sawtooth frequencies are increased excessively [13–15]. Real time control of ELM and sawtooth frequencies can play an important role in achieving the optimal compromise, avoiding tungsten accumulation while maintaining good confinement.

3.2. Divertor energy handling

A second, though linked, challenge posed by the metal wall is its limited power and energy handling. Maintaining a sufficiently high ELM frequency is again desirable, though other techniques also need to be employed. These techniques include sweeping the divertor strike-point location and the introduction of light impurities into the divertor region to radiate energy locally, creating a partially or fully detached plasma. Finally a reduction in the input power may prove necessary. Real time control can play a crucial role in con-

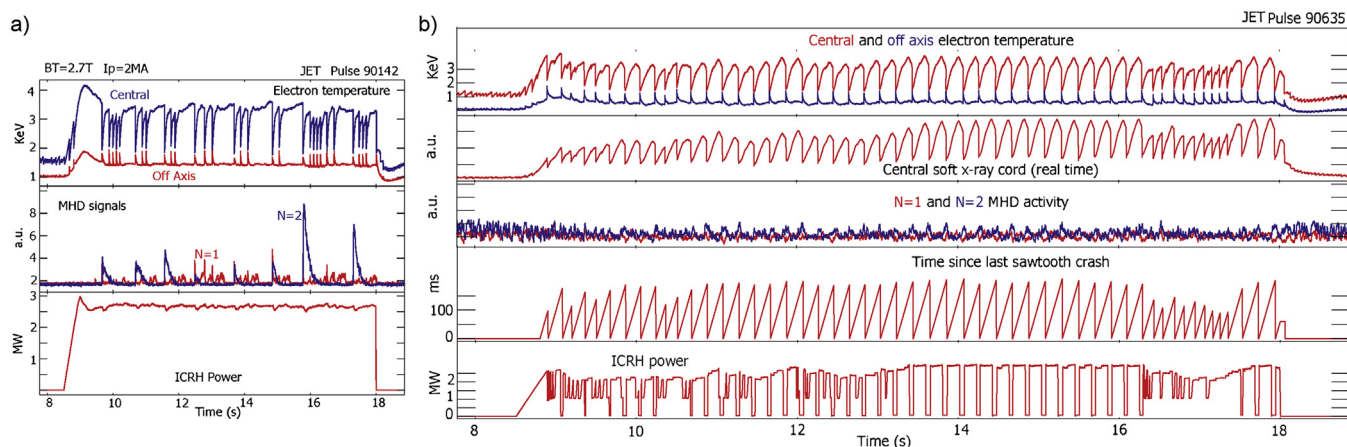

Fig. 3. Sawtooth and N=2 activity for two discharges: (a) Constant ICRH power. Long sawteeth trigger N=2 tearing modes. (90142); (b) Effective sawtooth pacing leading to the avoidance of the N=2 modes.

trolling radiation, detachment and divertor heat load allowing the best possible plasma performance while staying within the limits imposed by the divertor power and energy handling capability.

3.3. Disruptions

A less obvious complication in the operation with the metal wall is the fact that disruption forces have increased significantly in comparison with carbon wall operation [16,17]. This is exacerbated by the beryllium walls in the main chamber being prone to flash melting during disruptions. Prevention, prediction and mitigation of disruptions have therefore become even more important. Avoiding tungsten accumulation is probably the most important prevention action, though preventing the triggering of NTMs through sawtooth shortening and limitation of beta are also important. Early prediction that the plasma is heading towards a disruption may allow the disruption to be prevented by initiating a predetermined termination scenario [18,19]. A range of termination scenarios have been developed, each optimised for the specific conditions triggering the initiation of the termination. Once it is clear that a disruption is imminent the main mitigating action at JET is the firing of the disruption mitigation valve injecting a large amount of gas terminating the discharge rapidly while radiating most of the plasma energy.

3.4. Dud detection

The main concern when operating with tritium, especially in active operation with deuterium-tritium plasmas, is to make optimal use of the limited amount of tritium available and to consume the severely restricted neutron budget wisely. Determining, in real time, when a discharge is unlikely to be of scientific value and, if so, terminating it safely can result in significant reduction in neutron production and Tritium consumption. In DT discharges the simplest way to do this, already exploited during the JET DTE 1 experiments in 1997, is to monitor whether the neutron rate remains above a predetermined curve. Fig. 2 shows two hot ion ELM free H-mode discharges from 1997 when this method was used [1]. The best of these two pulses reached a peak fusion power of ~ 12 MW. Even for the short pulses in question a significant neutron saving was achieved by stopping one pulse early. Note that the second pulse was also stopped by the system, but only after the giant ELM which always terminated the high fusion yield phase of these discharges. Fig. 2 also includes a projection to the more steady discharges planned for the upcoming deuterium-tritium campaign, showing that a large neutron saving can be obtained by stopping ‘bad’ pulses

early. In the planned discharges higher NBI power, compared to 1997, will be required to achieve the same fusion power due to the need to run with regular ELMs. Other signals, such as impurity content and heating power can also be used to determine whether a discharge should be terminated early. At the detection of a ‘dud’ a termination similar to the normal end of a healthy pulse is instigated. During such a termination, other events may instigate more draconian actions in a progressing hierarchy of severity. An example could be the detection of wall overheating triggering a change of configuration. Later; the detection of an increased risk of disruption may trigger prevention and mitigations actions as described above.

3.5. Isotope control

A second issue, which will be more important during DT operation, is the control of the isotope ratio as required to achieve maximum fusion power. Controllers developed for this purpose are closely related to existing minority concentration controllers used in ICRH heated discharges.

4. Real time controllers in use at JET

A number of real time controllers have been developed at JET, each contributing to meeting one or more of the challenges outlined above. In the following, experimental evidence of the effectiveness of each of these controllers is discussed.

4.1. ELM frequency control

An ELM frequency controller is routinely used at JET. This controller exploits the fact that, under most conditions, the ELM frequency increases with gas injection rate. This controller, effective in its own right, is also regularly used as a ‘safety net’, only acting when the ELM frequency drops below a threshold. When this happens the controller injects gas to maintain the frequency at the required minimum. When triggering ELMs through pellet injection, this is particularly useful due to the variability in the pellet ELM triggering efficiency [13,20].

4.2. Sawtooth pacing

Controlling the sawtooth period with a view to preventing large sawtooth crashes from triggering of Neoclassical Tearing Modes (NTMs) has been investigated on JET over the last decade [21–24]. All the techniques developed in this research rely on locating the

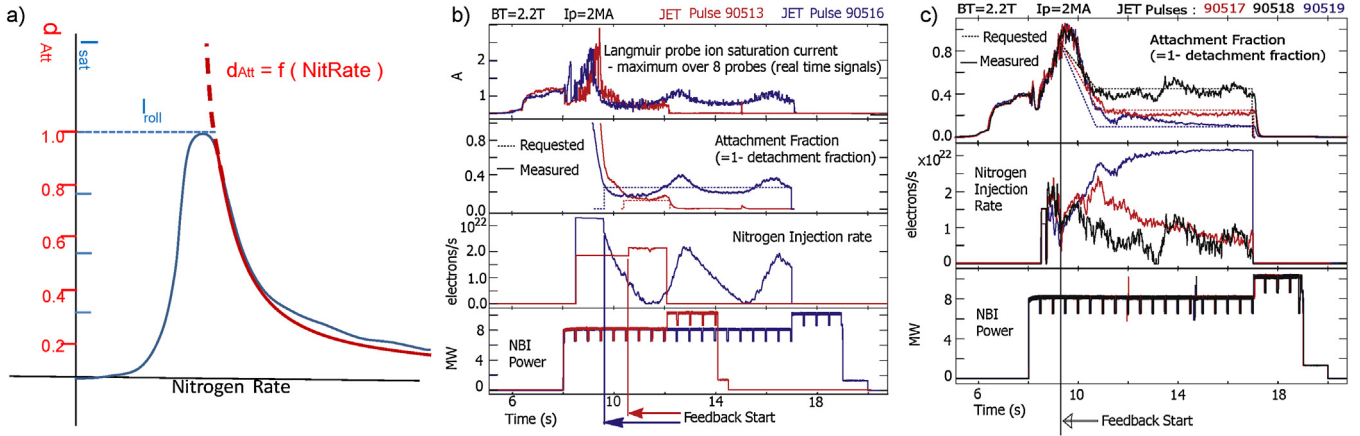

Fig. 4. (a) Sketch showing attachment fraction $d_{Att} = I_{sat}/I_{roll}$ as a function of input gas flow rate (blue) and an exponential curve matching this for nitrogen rates beyond the rollover (red). (b) and (c) Closed loop detachment control without (b) and with (c) compensation for the non-linearity seen in (a). Note that in the discharges in (c) the feedback was activated when the attachment fraction reached 0.8 as determined through prior knowledge of I_{roll} . (For interpretation of the references to color in this figure legend, the reader is referred to the web version of this article.)

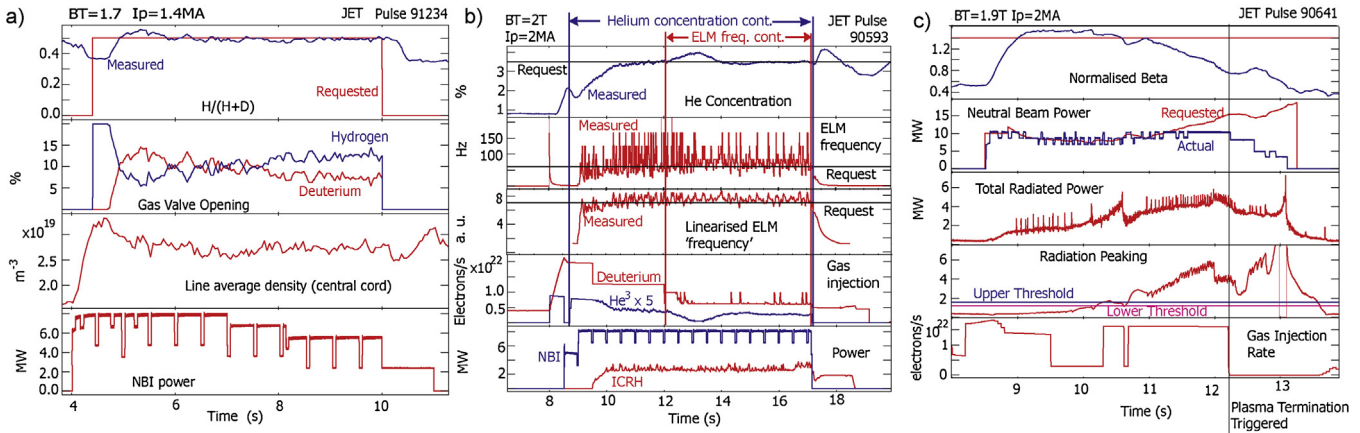

Fig. 5. (a) Hydrogen-Deuterium mixture control. (#91234). The controller compensates for the disturbance introduced by variations in the deuterium neutral beam power. The valve openings are limited by the controller to 20% of 'fully open'. (b) Simultaneous control of the ELM frequency and He_3 concentration by injection of Deuterium and He_3 gas. The third trace shows the behaviour of the 'linearized frequency' achieved by applying f^{-1} to both the requested and measured frequency as illustrated in Fig. 1(c). (c) Simultaneous operation of a normalised beta controller by NBI and a bang/bang control scheme aimed at reacting to radiation peaking. At 12.2 s a discharge termination is triggered due to the detection of MHD activity.

ICRH deposition near the $q=1$ surface to destabilise the $m,n=1,1$ mode, inducing more frequent sawteeth. Similar techniques using ECRH have been explored on other Tokamaks [25–28]. TCV has also demonstrated the pacing of sawteeth using modulation of centrally deposited ECRH [29,30]. Given the strong stabilising effect of central ICRH, pacing sawteeth using modulated centrally deposited ICRH should be very effective [31]. This has indeed been proven by recent experiments on JET [32]. In these experiments the ICRH modulation was controlled in real time, switching the ICRH power off when the time since the previous sawtooth crash exceeded a threshold and switching it back on when a new sawtooth crash is detected. Fig. 3 shows two pulses, (a) without sawtooth pacing and (b) with sawtooth pacing. In (a) long sawteeth lead to the triggering of $N=2$ modes (probably weak tearing modes) while sawteeth are effectively paced in (b) leading to the complete absence of long sawteeth and $N=2$ modes. In (b) the threshold for switching off the ICRH is set to 0.15s. The time between the request to switch off ICRH and the triggering of a sawtooth is ~ 50 ms in this pulse, leading to a sawtooth period < 0.2 s throughout the pulse. Note that the real time control means that the ICRH is not switched off when the natural sawtooth period is sufficiently short. The real time control therefore maximises the ICRH duty cycle allowing the optimal

use of ICRH for central heating and effective tungsten screening, while assuring NTM avoidance and tungsten flushing by keeping the sawtooth period low.

4.3. Detachment control

A feedback controller, controlling the divertor detachment fraction has recently been developed at JET [33]. The controller uses the ion saturation current (I_{sat}) measurements from an array of Langmuir probes, situated in the divertor, to determine the degree of detachment in real time. The detachment is controlled, in feedback, by injecting nitrogen into the divertor. Fig. 4a shows a sketch of the steady state map relating input gas to ion saturation current for the Langmuir probe situated closest to the divertor strike point. This curve exhibits a maximum and the value at this point is termed the 'roll over' saturation current I_{roll} . The degree of detachment d_{Det} at this point is zero by definition. At higher impurity injection rates the degree of detachment is defined as $d_{Det} = (I_{roll} - I_{sat})/I_{roll}$, which reaches one when the ion saturation current drops to zero. For simplicity the controlled value is the 'attachment fraction': $d_{Att} = 1 - d_{Det} = I_{sat}/I_{roll}$. With this definition Fig. 4a directly translates into showing attachment fraction as a function of gas injection

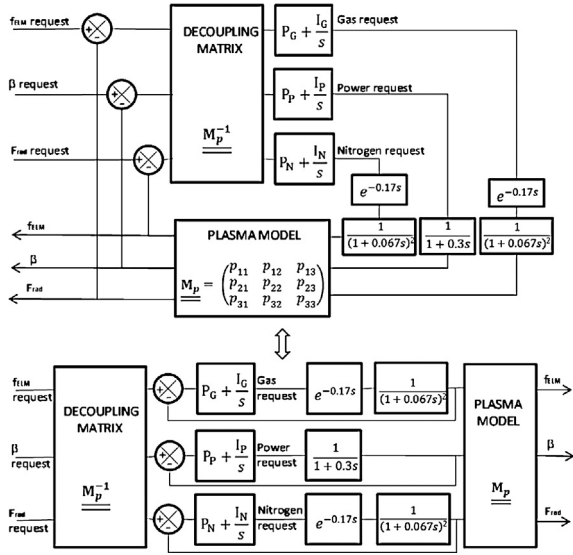

Fig. 6. MIMO controller – Top) 3 × 3 control block diagram. The decoupling matrix is the inverse of the steady state plasma matrix in the linearization point. Bottom) Equivalent block diagramme, showing how the decoupling, if perfect, results in 3 independent SISO control loops.

rate. As the input output map is non monotonic the controller sign must change when moving from left to right of the roll over point. This is handled by starting with a constant, large, gas flow, continuously detecting the maximum I_{sat} which has been reached since the start of the discharge. Once I_{sat} drops clearly below this maximum the controller assumes that the right hand side of the input output map, where d_{Att} decreases with increased gas injection, has been reached and closed loop control is started.

Fig. 4b shows the result of two similar discharges, one shortened for operational reasons, using this controller with different requested attachment fractions but with identical controller settings. In the case with a large requested attachment fraction, strong controller oscillations occur. The discharge with a smaller attachment fraction request shows no such oscillations. The short duration of this discharge makes it difficult to ascertain with certainty that no oscillation would develop in a longer pulse. The observation that the nitrogen injection actuator hardly varies in this discharge in sharp contrast to the significant variation seen in the early part of the oscillating discharge, leads us to surmise that the controller is stable in the case of low attachment request. The fact that low attachment fraction leads to stable controller behaviour while a higher attachment fraction results in controller oscillations is caused by the static non-linearity in the input output map. This can readily be confirmed through simple controller simulations. The non-linearity can be eliminated from the closed loop by introducing a non-linear compensating block in the control diagram as suggested in Fig. 1 resulting in stable operation over a range of attachment fractions as illustrated by Fig. 4c. The exponential curve used to produce the linearization, valid for nitrogen injection larger than the rollover value, is shown schematically by full and dashed red lines in Fig. 4a.

4.4. Plasma composition control

As mentioned in Section 2 it is desirable to control the isotope ratio, especially during DT operation. Fig. 5a shows an example where the isotope mix is maintained efficiently at 50% Hydrogen, 50% Deuterium by such a controller. Two gas injection modules, one injecting deuterium and one injecting hydrogen, are used simultaneously varying the ratio of the two gas injection rates, while

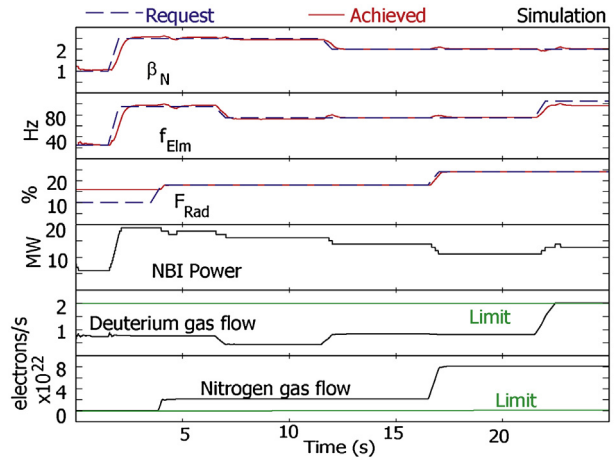

Fig. 7. MIMO controller simulation, including periods when one actuator touches a limit.

keeping the total injection rate constant. The isotope ratio is determined in real time using spectroscopic signals [34]. Similar control schemes are also used to control the He₃ minority fraction for optimisation of ICRH absorption.

5. Multi input multi output control

The previous section described a number of individual single input single output controllers. When moving on to Deuterium Tritium operation it is important that these controllers can operate together. Experience with the simultaneous operation of the controllers required for high power ILW operation remains very limited. Fig. 5b shows the JET ELM frequency and He₃ controllers operating together. It should be noted that the ELM frequency controller rapidly reaches saturation level and it is not clear whether the two controllers, which are likely to exhibit a not insignificant coupling, would have operated satisfactorily if neither of them had been running against their limits. Fig. 5c shows the operation of the JET standard beta controller using NBI power as actuator combined with a bang/bang controller which steps up the gas injection strongly when the plasma radiation peaking, defined as the ratio between a central and an off axis bolometer channel, is seen to exceed a certain threshold and reduces the gas injection again when the peaking returns below another, lower, threshold. In the discharge shown the gas helps to keep the plasma alive for a while but, eventually, strong MHD activity triggers a plasma termination.

The combination of controllers in Fig. 5 only scratches the surface of the likely future requirement for combining controllers. A study investigating the simultaneous use of deuterium injection D_{inj} , NBI power P_{NBI} and nitrogen injection N_{inj} to control ELM frequency f_{ELM} , normalised beta β_N and radiated fraction F_{Rad} , has been undertaken and a decoupled MIMO controller has been developed. The principle used in developing this controller is based on the observation that the main time constants in this system can be associated with the individual actuators. Around a certain operating point this allows us to describe the plasma as a 3 × 3 matrix \underline{M}_p :

$$\begin{pmatrix} f_{ELM} \\ \beta_N \\ F_{Rad} \end{pmatrix} = \underline{M}_p \cdot \begin{pmatrix} D_{inj} \\ P_{NBI} \\ N_{inj} \end{pmatrix}$$

By inserting \underline{M}_p^{-1} into the controller, as illustrated in Fig. 6 (top), we can eliminate the cross coupling terms. Fig. 6 (bottom) shows that this is equivalent of controlling the linear combinations $\begin{pmatrix} y_a \\ y_b \\ y_c \end{pmatrix} = \underline{M}_p^{-1} \cdot \begin{pmatrix} f_{ELM} \\ \beta_N \\ F_{Rad} \end{pmatrix}$ towards the ref-

$$\begin{pmatrix} r_a \\ r_b \\ r_c \end{pmatrix} = \underline{\underline{\mathbf{M}}}^{-1} \cdot \begin{pmatrix} f_{ELM_Request} \\ \beta_{N_Request} \\ F_{Rad_Request} \end{pmatrix}$$

in three independent SISO control loops. Fig. 7 shows a simulation of the behaviour of such a controller. Though the matrix used for determining the decoupling matrix is based on a specific operating point, the model used for the simulation does take into account, albeit crudely, the nonlinear plasma response. The simulation also takes into account that the NBI power can only be varied in steps of ~ 1 MW and it handles the case where an actuator reached a limit. In this case the control variable most closely associated with the limiting actuator is removed and the controller becomes a 2×2 controller until such time that the full controller would request the limiting actuator to move back off the limit.

6. Conclusions

Operation of JET with the all metal ITER like wall together with the planned operation with Deuterium Tritium plasma poses a variety of challenges. A number of real time controllers have been developed to help meeting these challenges, including ELM and sawtooth frequency controllers, detachment controllers and mixture controllers. Assuring that these controllers can be combined effectively remains the main real time control task to be completed in preparation for the upcoming Deuterium Tritium experimental campaigns.

Acknowledgments

This work has been carried out within the framework of the EUROfusion Consortium and has received funding from the Euratom research and training programme 2014–2018 under grant agreement No. 633053. The views and opinions expressed herein do not necessarily reflect those of the European Commission. The work of A. Chagnard received the support of the French Embassy in London.

References

- [1] M. Keilhacker, et al., Nucl. Fusion 39 (1999) 209.
- [2] F. Romanelli, et al., Nucl. Fusion 53 (2013) 104002.
- [3] G.F. Matthews, et al., Phys. Scr. (2011) 014001.
- [4] R. Neu, et al., Phys. Plasmas 20 (2013) 056111.
- [5] Q. King, H. Brelen, JET preprints JET-P(98) (1998). <http://www.euro-fusionscipub.org/wp-content/uploads/2014/11/JETP980241.pdf>.
- [6] R. Neu, et al., Plasma Phys. Control. Fusion 49 (12B) (2007) B59–B70.
- [7] E. Joffrin, et al., Nucl. Fusion 54 (2014) 013011.
- [8] M. Beurskens, et al., Plasma Phys. Control. Fusion 55 (2013) 124043.
- [9] T. Pütterich, et al., Plasma Phys. Control. Fusion 55 (2013) 124036.
- [10] J. Graves, et al., Plasma Phys. Control. Fusion 57 (2015) 014033.
- [11] I. Chapman, et al., Nucl. Fusion 50 (2010) 102001.
- [12] E. Lerche, et al., Nucl. Fusion 56 (2016) 036022.
- [13] M. Lennholm, et al., Nucl. Fusion 56 (2016) 016008.
- [14] G. Saibene, et al., JNM 241–243 (476) (1997).
- [15] M.N.A. Beurskens, et al., Nucl. Fusion 54 (2014) 043001.
- [16] P.C. de Vries, et al., Phys. Plasmas 21 (2014) 056101.
- [17] C. Reux, et al., Fusion Eng. Des. 88 (2014) 1101.
- [18] J. Vega, et al., Fusion Eng. Des. 88 (6–8) (2014) 1228.
- [19] R. Moreno, J. Vega, et al., Fusion Sci. Technol. 69 (2016) 485.
- [20] M. Lennholm, et al., Nucl. Fusion 55 (2015) 063004.
- [21] L.-G. Eriksson, et al., Phys. Rev. Lett. 92 (2004) 235004.
- [22] J.P. Graves, et al., Nat. Commun. 3 (2012) 626.
- [23] J.P. Graves, et al., Phys. Rev. Lett. 102 (2009) 065005.
- [24] M. Lennholm, et al., Nucl. Fusion 51 (2011) 073032.
- [25] C. Angioni, et al., Nucl. Fusion 43 (2003) 455.
- [26] A. Mück, et al., Plasma Phys. Control. Fusion 4 (3) (2005) 1633.
- [27] J.I. Paley, et al., Plasma Phys. Control. Fusion 51 (2009) 055010.
- [28] M. Lennholm, et al., Phys. Rev. Lett. 102 (2009) 115004.
- [29] T.P. Goodman, et al., Phys. Rev. Lett. 106 (2011) 245002.
- [30] M. Lauret, et al., Nucl. Fusion 52 (2012) 062002.
- [31] M. Lauret, et al., Plasma Phys. Control. Fusion 58 (2016) 124004.
- [32] E. Lerche, et al., Nucl. Fusion 57 (2017) 036027.
- [33] C. Guillemaut, et al., Submitted PPCF, Plasma Phys. Control. Fusion 59 (2017) 045001.
- [34] D. Valcarcel et al., in preparation.