

Upgrade of the tangential gamma-ray spectrometer beam-line for JET DT experiments

Original

Upgrade of the tangential gamma-ray spectrometer beam-line for JET DT experiments / Curuia, M., Craciunescu, T., Soare, S., Zoita, V., Braic, V., Croft, D., Fernandes, A., Figueiredo, J., Goloborod'Ko, V., Gorini, G., Griph, S., Kiptily, V., Lengar, I., Mianowski, S., Naish, J., Naish, R., Nocente, M., Pereira, R.C., Riccardo, V., Schoepf, K., et al.. - In: FUSION ENGINEERING AND DESIGN. - ISSN 0920-3796. - 123:(2017), pp. 749-753. [10.1016/j.fusengdes.2017.05.064]

Availability:

This version is available at: 11583/2986885 since: 2024-03-12T16:02:00Z

Publisher:

ELSEVIER SCIENCE SA

Published

DOI:10.1016/j.fusengdes.2017.05.064

Terms of use:

This article is made available under terms and conditions as specified in the corresponding bibliographic description in the repository

Publisher copyright

(Article begins on next page)

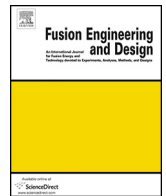

Upgrade of the tangential gamma-ray spectrometer beam-line for JET DT experiments



Marian Curuia^{a,*}, Teddy Craciunescu^a, Sorin Soare^a, Vasile Zoita^a, Viorel Braic^a, David Croft^b, Ana Fernandes^c, Joao Figueiredo^{c,h}, Victor Goloborod'ko^d, Giuseppe Gorini^e, Sverker Griph^b, Vasily Kiptily^b, Igor Lengar^f, Slavomir Mianowski^g, Jonathan Naish^b, Richard Naish^b, Massimo Nocente^e, Rita Costa Pereira^c, Valeria Riccardo^b, Klaus Schoepf^d, Bruno Santos^c, Marco Tardocchi^e, Victor Yavorskij^{d,2}, Izabella Zychor^g, JET contributors¹

^a Institute of Atomic Physics, Magurele, Ilfov, Romania

^b Culham Centre for Fusion Energy, Culham Science Centre, Abingdon, United Kingdom

^c Instituto de Plasmas e Fusao Nuclear, Instituto Superior Tecnico, Universidade de Lisboa, Lisboa, Portugal

^d University of Innsbruck, Fusion@Österreichische Akademie der Wissenschaften, Austria

^e Istituto di Fisica del Plasma "Piero Caldirola", Consiglio Nazionale delle Ricerche, and Dipartimento di Fisica "G. Occhialini", Università degli studi di Milano Bicocca, Milano, Italy

^f Slovenian Fusion Association, Jozef Stefan Institute, Reactor Physics Department, Ljubljana, Slovenia

^g Narodowe Centrum Badań Jądrowych (NCBJ), 05-400 Otwock, Poland

^h EUROfusion Programme Management Unit, Culham Science Centre, Abingdon, United Kingdom

H I G H L I G H T S

- The upgraded beam-line for the JET tangential gamma-ray spectrometer (KM6T) will provide a clear definition of the spectrometer field-of-view inside a DT plasma.
- The components of the RFCA will also define and control the neutron and gamma-ray fields at the KM6T detector.
- The fast neutron flux at the detector location can be attenuated by a factor of about 275 for high power DT pulses.

A R T I C L E I N F O

Article history:

Received 3 October 2016

Received in revised form 12 May 2017

Accepted 12 May 2017

Available online 20 May 2017

Keywords:

Tokamak

Diagnostics

Gamma-rays

Gamma-ray spectrometer

Neutron attenuators

A B S T R A C T

The JET tangential gamma-ray spectrometer is undergoing an extensive upgrade in order to make it compatible with the forthcoming deuterium-tritium (DT) experiments. The paper presents the results of the design for the main components for the upgrade of the spectrometer beam-line: tandem collimators, gamma-ray shields, and neutron attenuators. The existing tandem collimators will be upgraded by installing two additional collimator modules. Two gamma-ray shields will define the gamma-ray field-of-view at the detector end of the spectrometer line-of-sight. A set of three lithium hydride neutron attenuators will be used to control the level of the fast neutron flux on the gamma-ray detector. The design of the upgraded spectrometer beam-line has been supported by extensive radiation (neutron and photon) transport calculations using both large volume and point radiation sources.

© 2017 The Authors. Published by Elsevier B.V. This is an open access article under the CC BY-NC-ND license (<http://creativecommons.org/licenses/by-nc-nd/4.0/>).

1. Introduction

Gamma-ray emission of tokamak plasmas is the result of the interaction of fast ions (fusion reaction products, including alpha particles, neutral beam injector ions, ICRH-accelerated ions) with main plasma impurities (e.g., carbon, beryllium). For the JET tokamak, gamma-ray diagnostics has been used to provide information

* Corresponding author.

E-mail addresses: marian.curuia@icsi.ro, marian@icsi.ro (M. Curuia).

¹ See the Appendix of F. Romanelli et al., Proceedings of the 25th IAEA Fusion Energy Conference 2014, Saint Petersburg, Russia.

² Deceased.

on the characteristics of the fast ion population in plasmas [1]. The applicability of gamma-ray diagnostics to high performance deuterium and deuterium-tritium JET discharges is strongly dependent on the fulfillment of rather strict requirements for the definition and characterization of the neutron and gamma radiation fields. It is thus necessary to define clearly the gamma-ray detector field of view, to provide adequate radiation collimation, shielding and attenuation, and to identify parasitic gamma-ray sources. Design solutions aimed at fulfilling such requirements have been developed for the beam-line of a major component of the JET gamma-ray diagnostics: the gamma-ray spectrometer with a quasi-tangential line of sight (KM6T in JET nomenclature).

The upgrade of the JET tangential gamma-ray spectrometer beam-line consists of the design, manufacturing and installation of a Radiation Field Components Assembly (RFCA), a complex system of shields and attenuators for both neutron and gamma radiations. The RFCA extends over a distance of about 25 m from the main horizontal vacuum port in octant 8 to the gamma-ray detector inside a bunker behind the south wall of the JET experimental hall [2]. The main purpose of the RFCA is to provide a suitable definition for the spectrometer field-of-view. At the same time the RFCA should reduce the gamma-ray background at the spectrometer detector and thus improve its signal-to-background ratio. For the KM6T spectrometer this ratio is defined in terms of the plasma-emitted gamma radiation and the gamma-ray background [3].

The Radiation Field Components Assembly has the following main components, from the plasma to the detector:

- Two tandem collimators [4] which define the spectrometer field-of-view inside the JET plasma. The tandem collimators, Fig. 1, are provided with additional collimator modules in order to fulfil the requirements for DT operation;
- Two gamma-ray shields (a Movable Gamma-Ray Shield, MGRS, and a Fixed Gamma-Ray Shield, FGRS, Fig. 2) for minimizing the flux of parasitic gamma radiation reaching the detector. This parasitic radiation will be produced by the interaction of the fast neutron flux with components inside the spectrometer bunker;
- A set of three LiH neutron attenuators (NA in Fig. 2) whose the aim is to reduce the fast neutron flux at the gamma-ray detector position.

The design of the new KM6T spectrometer beam-line evolved through several stages. During a first stage (conceptual design, [2]) selected materials were chosen for their nuclear properties and approximate dimensions of the active components were obtained by analytical calculations. The nuclear performance of the resulted system was evaluated by radiation transport calculations using the MCNP6 code [5] and ENDF/B-VII, a general purpose library suitable for fusion application [6]. Based on the numerical results, the design went to a second stage, scheme design, during which the main components were defined. The performance was again evaluated by another series of MCNP numerical simulations (presented below in chapter 5) before going to the final stage of the design, the detailed design.

2. Design of the gamma-ray shields

The gamma-ray shields are positioned inside a bunker on the south wall of the JET experimental hall, behind an X-ray spectrometer chamber (KX1 spectrometer, in Fig. 2). A first gamma-ray shield is vertically movable with three equidistant working positions, while a second shield is bolted onto a metal sheet placed on the vertical bunker wall. For the Movable Gamma-Ray Shield the materials of choice were stainless-steel (SS 304) metal sheet for the casings and slabs of nuclear grade lead for the shielding mate-

rial. The two lids which close the movable shield assembly are also made of SS metal sheet. The casing structure is reinforced by two SS rings welded to it towards both ends. The casing elements are bolted. The shield is securely fixed to a cradle which is bolted to a U-channel that transfers the load to an electro-mechanical driver system. The vertical movement is driven by a jack system powered by an electric motor, Fig. 3.

The electrical motor and movable shield assembly is supported by a frame fixed onto the bunker wall and floor. MGRS has the following working positions and corresponding functions (Fig. 3):

- Bottom: maximum neutron attenuation thickness, for DT discharges;
- Middle: middle working position, for gamma-ray shutter;
- Top: minimum attenuation thickness, for DD discharges.

MGRS has to be moved to the top or to the bottom positions as required by experiments. MGRS in its middle position is to be used as a gamma-ray shutter for the measurement of the gamma-ray background at the detector location during a JET pulse.

The movable shield assembly is an all-welded casing the only detachable part being the lid which is bolted.

The movable shield CAD model (CATIA, [7]) was transferred into commercially available finite element analysis (FEA) software (ANSYS, [8]) to evaluate the mechanical behaviour during installation procedure and long-time operation.

The FEA results have shown that during operation the assembly shows no signs of excessive deformation nor did it experience high levels of stress (distributed or concentrated) compared to the tensile yield of SS304.

The fixed gamma-ray shield is bolted onto a steel plate that is attached to the spectrometer bunker wall. The fixed shield is an all-welded structure made of SS304 sheet housing a nuclear grade lead slab cut at an angle of 22.5deg to match the bunker wall configuration. The central bore is designed to accommodate the protruding end of a neutron attenuator (flange side) and its sleeve.

A similar finite element analysis was also done for the fixed shield. The FEA model shows neither excessive deformation nor high levels of equivalent stress compared with the tensile yield of SS304.

3. Control and monitoring of the movable shield operation

The Movable Gamma-Ray Shield can be locally controlled and monitored by the JET Control and Data Acquisition System (CODAS) through a dedicated Programmable Logic Controller (PLC), Fig. 4.

An operator unit interface connected to the PLC provides an easy way to initiate the MGRS movements. These are initiated by using the operator unit interface, the position of the shield being monitored by CODAS. The PLC can also be controlled remotely by means of an Ethernet connection (Eth, in Fig. 4). The position of the movable shield is detected with three photoelectric sensors, corresponding to the three shield working positions. Based on the signal provided by these sensors the PLC commands the electric motor that drives the jack system. The electric motor is equipped with a brake that is activated when the motor is not energized and thus keeps the shield in position.

4. Design of the neutron attenuators

The 14.1 MeV neutron flux at the KM6T detector location should be significantly reduced in order to perform proper gamma-ray measurements. This will be achieved by the manufacturing and installation of a set of lithium hydride (LiH) neutron attenuators. The choice of LiH material has the advantage of avoiding carbon-

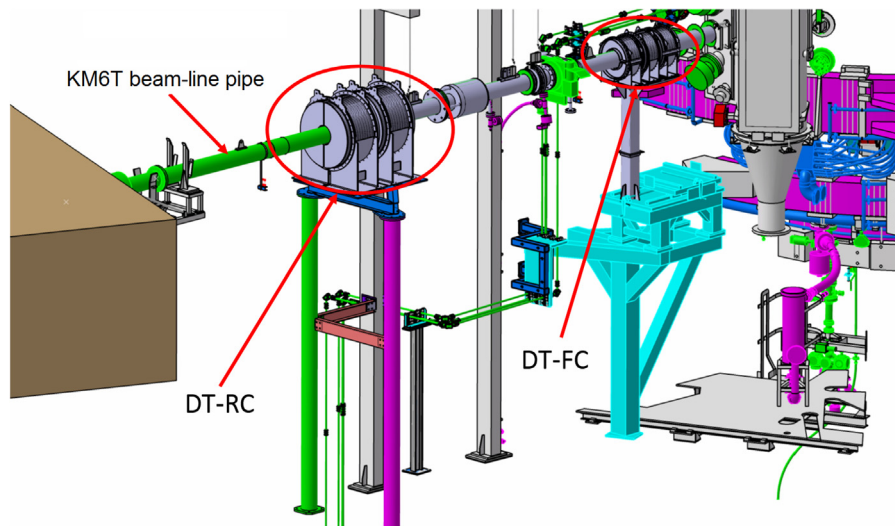

Fig. 1. Upgraded KM6T tandem collimators. DT-FC: Front Collimator for DT pulses. DT-RC: Rear Collimator for DT pulses.

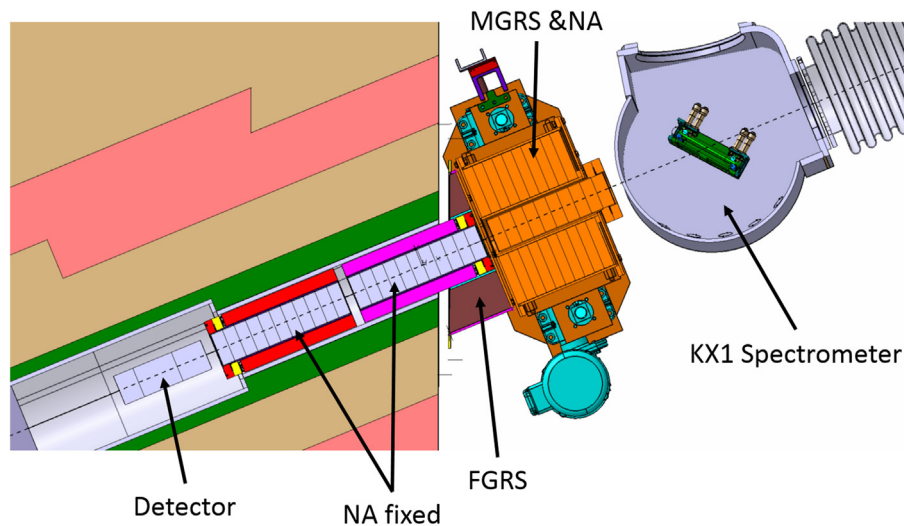

Fig. 2. Radiation Field Components Assembly at the detector end of the KM6T beam-line. MGRS: Movable Gamma-Ray Shield; FGRS: Fixed Gamma-Ray Shield; NA: Neutron Attenuator.

containing materials which lead to the production of inelastic scattering neutrons with energies $E > 5$ MeV from $^{12}\text{C}(n,n'\gamma)^{12}\text{C}$ reactions and, consequently, to a high background of 4.44 MeV gamma-rays. LiH with a natural Li composition is compact, effective and well transparent to the plasma-emitted MeV gamma-rays. It does not produce interfering gamma-rays in the high-energy range of interest to gamma-ray plasma diagnostics.

The KM6T LiH attenuators, Fig. 5, are made of a stack of LiH discs placed inside a cylindrical high vacuum stainless steel enclosure, closed by ConFlat Flanges. The KM6T spectrometer beam-line will contain three LiH neutron attenuators. One attenuator is placed inside the movable gamma-ray shield and thus it can be moved in and out of the detector line-of-sight depending on the planned experiment. Another two LiH attenuators will sit, one after another, in front of the gamma-ray detector. These attenuators were designed to provide in their full-length configuration (three attenuators in line) a reduction of the neutron flux at the KM6T detector by at least a factor of 10^4 for 2.45 MeV neutrons and 10^2 for 14.1 MeV neutrons, respectively.

5. Radiation transport calculations for the beam-line design

The performance of the designed KM6T beam-line has been evaluated by radiation transport calculations using the MCNP numerical code. The full structure of the Radiation Field Components Assembly from the plasma end of the beam-line to the detector and beyond have been taken into account. These calculations cannot be performed in a straightforward manner due to the extreme decline of the neutron flux from the plasma to the KM6T detector position (this decline amounts to several orders of magnitude). Therefore the problem has been split into two parts. First, the neutron field along the JET Torus Hall part of the KM6T beam-line was computed. The neutron flux on a circular surface located at the entrance into the JET Torus Hall south wall penetration was estimated.

This estimation based on a large volume radiation source (part of a JET DT plasma) is used afterwards in a second stage of transport calculations to construct circular planar neutron and gamma-ray sources, emitting particles perpendicular to the south wall penetration, in a cone characterized by an angle of 10° . These point sources

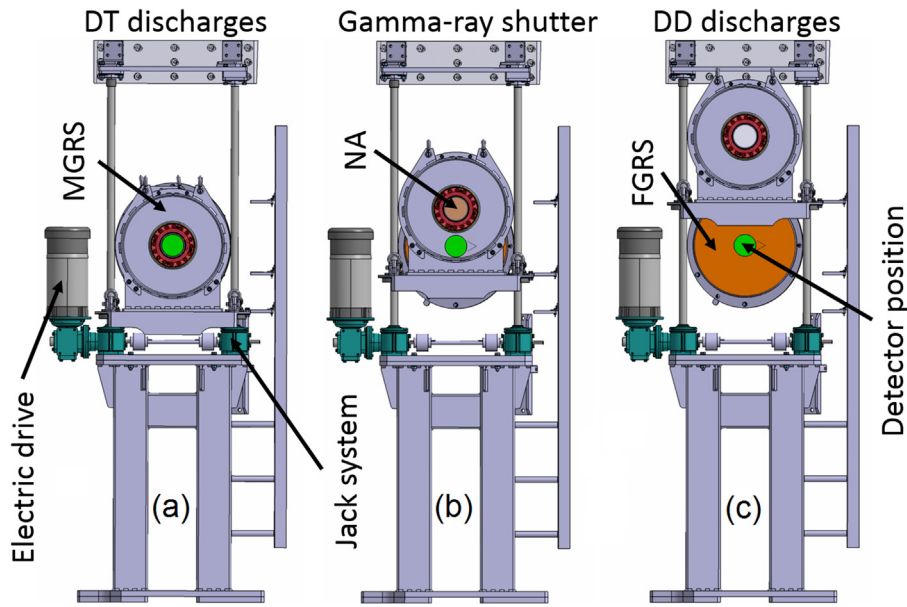

Fig. 3. Movable Gamma-Ray Shield (MGRS) working positions: (a): lower position for DT discharges; (b): middle position for gamma-ray shutter; (c): top position for DD discharges. FGRS: Fixed Gamma-Ray Shield. NA: Neutron Attenuator. The green disc (Detector position) represents the projection of the KM6T detector front face. (For interpretation of the references to colour in this figure legend, the reader is referred to the web version of this article.)

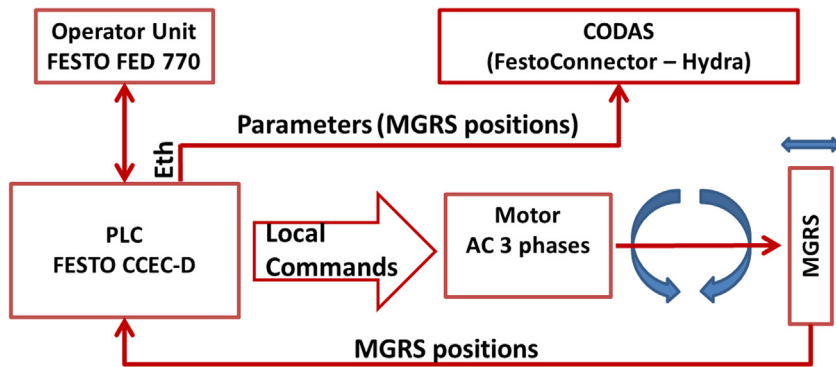

Fig. 4. Movable Gamma-Ray Shield (MGRS) command and control. PLC: Programmable Logic Controller; Eth: Ethernet connection; CODAS: Control and Data Acquisition System.

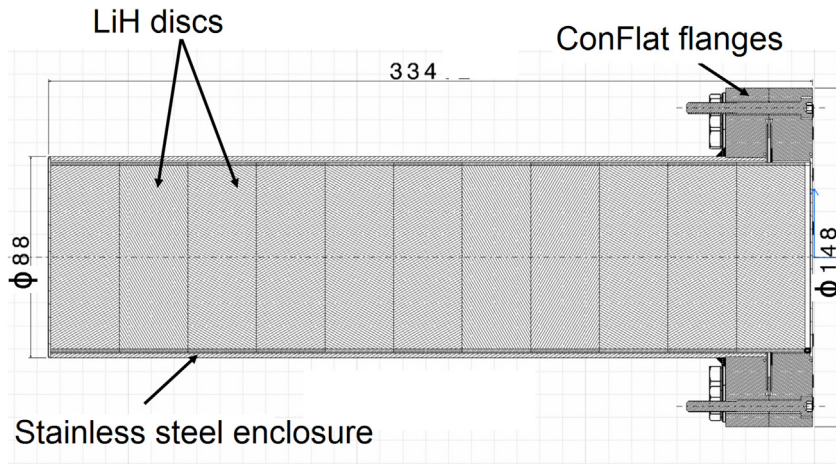

Fig. 5. Cross-section showing the structure of a neutron attenuator.

have been used to restart the MCNP simulation and to evaluate the radiation field at the detector position. Several variance reduction techniques were used in order to obtain satisfactory results.

One of the results of the first stage of computation was a clear illustration of the radiation emitting regions defined by the upgraded KM6T beam-line inside a DT JET plasma. In Fig. 6 the blue

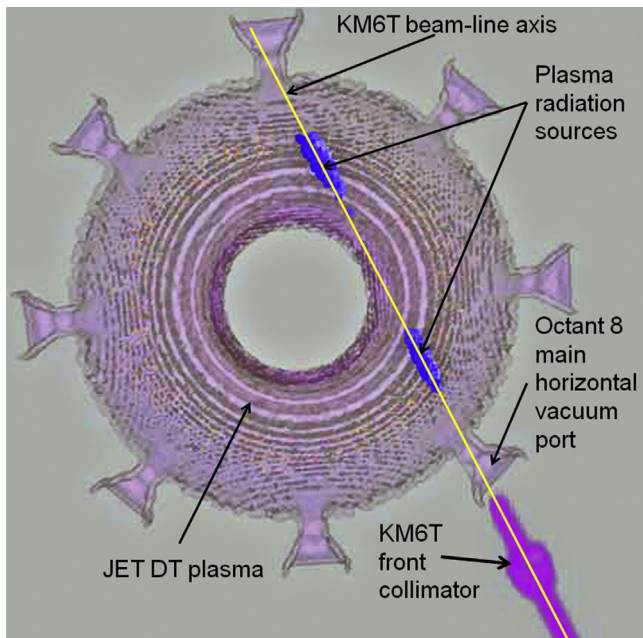

Fig. 6. Horizontal cross-section through the JET plasma showing the radiation sources (the blue elongated areas) for the KM6T tangential gamma-ray spectrometer. The spectrometer beam-line axis is shown by the yellow line. (For interpretation of the references to colour in this figure legend, the reader is referred to the web version of this article.)

elongated areas represent horizontal cross-sections through the neutron emitting regions of the plasma seen by the KM6T detector. This confirms previous estimations [3] for the KM6T field-of-view inside the JET plasma. Eventually the MCNP calculations provided an estimate for the neutron attenuation factor for the LiH attenuators for two energy ranges of interest for the JET DD and DT discharges. The procedure for the evaluation of a neutron attenuator performance by means of MCNP transport calculations was presented in detail in [9]. It has been developed for a different type of neutron attenuator (water as the active material) and for a different JET diagnostics (gamma-ray cameras). In the case of the KM6T spectrometer for deuterium discharges (neutron energy peak at 2.45 MeV) the attenuation factor is estimated at approximately 900 for neutrons in the energy range (1.9–2.8) MeV. For deuterium-tritium JET discharges (neutron energy peak at 14.1 MeV) the attenuation factor the estimate is approximately 275 for neutrons in the energy range (13.9–15) MeV. This shows that the values of the required neutron attenuation factor for the upgraded KM6T beam-line can be easily attained with the new design.

6. Conclusions

The upgraded beam-line for the JET tangential gamma-ray spectrometer (KM6T) will provide a clear definition of the spectrometer field-of-view inside a DT plasma. The components of a radiation field components assembly will also define and control the neutron and gamma-ray fields at the KM6T detector. The fast neutron flux at the detector location can be attenuated by a factor of about 275 for high power DT pulses. Lower attenuation factors can be set for deuterium pulses and low power DT ones. This is made possible by a set of three LiH neutron attenuators and a remotely controlled movable gamma-ray shield comprising one of the three attenuators. The same movable gamma-ray shield can be used as a gamma-ray shutter in front of the KM6T detector.

Acknowledgments

This work has been carried out within the framework of the EUROfusion Consortium and has received funding from the EURATOM research and training programme 2014–2018 under grant agreement No 633053. The views and opinions expressed herein do not necessarily reflect those of the European Commission.

References

- [1] V.G. Kiptily, et al., Gamma ray diagnostics of high temperature magnetically confined fusion plasmas, *Plasma Phys. Control. Fusion* 48 (2006) R59–R82.
- [2] V. Zoita, et al., Upgrade of the JET tangential gamma-ray spectrometer, in: *Conceptual Design 23rd Symposium on Fusion Engineering*, San Diego, California, May–June, 2009.
- [3] V. Zoita, et al., Definition of the radiation fields for the gamma-ray spectrometer diagnostics, *Fusion Eng. Des.* 88 (2013) 1366.
- [4] S. Soare, et al., Tandem Collimators for the JET tangential gamma-ray spectrometer, *Fusion Eng. Des.* 86 (2010) 1359.
- [5] T. Goorley, et al., Initial MCNP6 release overview, *Nucl. Technol.* 180 (2012) 298–315.
- [6] M.B. Chadwick, et al., ENDF/B-VII.1: nuclear data for science and technology: cross sections, covariances, fission product yields and decay data, *Nucl. Data Sheets* 112 (2011) 2887.
- [7] CATIA Dassault Systèmes HQ10, Rue Marcel Dassault 78140, Vélizy-Villacoublay, France.
- [8] ANSYS product of ANSYS Inc., Canonsburg, PA 15317, USA.
- [9] V. Zoita, et al., Design of the JET upgraded gamma-ray cameras, *Fusion Eng. Des.* 84 (2009) 2052.