

Enhancing resilience by reducing critical load loss via an emergent trading framework considering possible resources isolation under typhoon

Original

Enhancing resilience by reducing critical load loss via an emergent trading framework considering possible resources isolation under typhoon / Wu, Y.j., Liu, C.j., Lin, Z.w., Ru, Y.t., Huang, T.. - In: IET GENERATION, TRANSMISSION & DISTRIBUTION. - ISSN 1751-8687. - ELETTRONICO. - 17:14(2023), pp. 3184-3197. [10.1049/gtd2.12888]

Availability:

This version is available at: 11583/2983622 since: 2023-11-06T12:20:29Z

Publisher:

INST ENGINEERING TECHNOLOGY-IET

Published

DOI:10.1049/gtd2.12888

Terms of use:

This article is made available under terms and conditions as specified in the corresponding bibliographic description in the repository

Publisher copyright

(Article begins on next page)

IET Generation, Transmission & Distribution

Special issue Call for Papers

**Be Seen. Be Cited.
Submit your work to a new
IET special issue**

Connect with researchers and experts in your field and share knowledge.

Be part of the latest research trends, faster.

[Read more](#)



Enhancing resilience by reducing critical load loss via an emergent trading framework considering possible resources isolation under typhoon

Yingjun Wu¹  | Chengjun Liu¹ | Zhiwei Lin¹ | Yingtao Ru¹ | Tao Huang²

¹Department of Electrical Engineering, College of Energy and Electrical Engineering, Hohai University, Nanjing, China

²Department of Energy, Politecnico di Torino, Turin, Italy

Correspondence

Yingjun Wu, Department of Electrical Engineering, College of Energy and Electrical Engineering, Hohai University, Nanjing, China.
Email: yingjunwu@hotmail.com

Funding information

Fundamental Research Funds for the Central Universities, Grant/Award Number: B230201048

Abstract

Leveraging distributed resources to enhance distribution network (DN) resilience is an effective measure in response to natural disasters. However, the willingness and economy of distributed resources are typically ignored. To address this issue, this paper proposes an emergent trading framework that uses parking lots (PLs) as resources to provide power support to critical loads (CLs) in a blackout due to typhoons. In this trading framework, an evolutionary Stackelberg game-based trading model is established to consider maximizing all stakeholders' economic benefits, considering possible resources isolation under typical fault scenarios caused by typhoons, and a benefit allocation mechanism is proposed for all stakeholders to motivate all stakeholders to participate in the trading. This framework allows that critical loads could reduce their load loss, parking lots could receive adequate compensation to stimulate them to participate in the trading, and distribution utility could ensure its economic benefits. Furthermore, an iterative evolutionary-Stackelberg solution set-up is applied to obtain the equilibria of the proposed framework. Simulation results on the modified IEEE 69-bus test system and IEEE 123-bus test system reveal the validity of the proposed method.

1 | INTRODUCTION

Frequent natural disasters have exposed the vulnerability of the power system under unpredictable extreme weather in recent years [1–4], which could lead to a large-scale and long-playing outage of the power system. In this context, not only the reliability of the power system in the conventional sense needs to be improved, but also the resilience of the entire distribution network (DN) needs to be enhanced.

To analyse the impact of extreme weather on the power system, it is necessary to classify and model extreme weather [5]. As one of the most frequent happening extreme weather, the wind hazard has been studied by scholars for many years [6–10]. Reference [7] analyses the impact of a hurricane on a real power system, and proposes a hurricane modelling approach. Reference [8] models wind storms and analyse their impact on the DN in the northeast United States. Reference [9] proposes a probabilistic typhoon model and assesses the impact

on transmission systems. Reference [10] analyses the effect of typhoon track uncertainty on power system lines. Obviously, wind hazards, as one of the most frequent and high destructive natural hazards, should be prioritized in the consideration for the improvement of the power system resilience.

In the context of power systems, resilience could be defined as the grid's ability to withstand extraordinary and high-impact low-probability events [1]. Power system resilience covers the entire process from grid preparation before a disaster, emergency operation during a disaster, and rapid recovery after a disaster. The development of the smart grid brings higher flexibility, security, and self-healing capacity. Especially, distributed energy resources bring more flexible and effective fault response strategies to the power system and make it possible to actively improve the resilience of the DN. The rapid restoration of power supply in the DN after a disaster is a research hotspot [11, 12]. The rapid restoration operation utilizes novel technologies to leverage existing distributed energy resources

This is an open access article under the terms of the [Creative Commons Attribution-NonCommercial-NoDerivs](https://creativecommons.org/licenses/by-nc-nd/4.0/) License, which permits use and distribution in any medium, provided the original work is properly cited, the use is non-commercial and no modifications or adaptations are made.

© 2023 The Authors. *IET Generation, Transmission & Distribution* published by John Wiley & Sons Ltd on behalf of The Institution of Engineering and Technology.

in the DN to defend the system or reduce the disastrous consequence. Due to its flexibility and wide distribution, electric vehicle (EV) is usually considered as a recovery resource after hazards [13]. References [14–16] propose some strategies to achieve rapid power restoration with EVs. References [17, 18] respectively optimize the location of parking lots (PLs) and electric buses to prevent the harm the disaster brings. Reference [19] focuses on the optimization of the vehicle-to-home problem during a power blackout. Reference [20] presents a two-stage framework of rapid power recovery with the utilization of distributed resources including EVs. In summary, EVs have a place in researches on DN resilience enhancement and can be used as a quick power recovery resource during an outage. Yet, when considering rapid power restoration by using EVs, references [14, 15, 17, 18, 19] do not consider the availability of the EVs as well as the locations where the fault occurred. However, faults at different locations in the DN may result in very different outcomes, and it is important to take this into account in the power load recovery. Further, many studies, including the above-mentioned ones, directly dispatch EVs in an outage due to a disaster. However, most EVs do not belong to the DN. Therefore, if the economic benefits of the EV owners cannot be guaranteed, their willingness of participating in the power recovery will decrease.

Therefore, a reasonable market mechanism could significantly increase resource owners' willingness to cooperate with the DN [21–23]. Market approaches can be also effective in emergency conditions; the emergency demand response program for large load users (non-distributed resource) is an example in point [24–26]. Reference [24] presents a demand response program that could maintain the system's reliability during the emergency period. Reference [25] uses Nash bargaining theory to design an incentive mechanism in emergency demand response for data centres. In [26], an emergency demand response program is designed to improve short-term voltage stability. These large loads themselves are much vulnerable to disaster than distributed resources; thus, they cannot provide flexibility when the system needs. Therefore, it is more suitable to consider distributed resources as quick power recovery resources. Yet, due to their distributed and small-scale natures, a specifically designed market instrument is absolutely needed to effectively stimulate their participation in this process. Therefore, this paper proposes an emergent trading framework to encourage their participation to enhance the system's resilience.

It should be noted that market-based instruments may lead to free-riding behaviour among the critical load users who buy the resilience enhancement services in the market, especially in the DN due to its topological features. Such free-riding behaviour has been studied in the traditional distribution power reliability [27] in normal situations. Not to mention that free-riders may cause greater harm under emergency. To overcome this issue, this paper introduces a penalty to reduce its impact.

This paper proposes a market-based framework applied to emergent or extreme situations by using PLs as a quick recovery resource to reduce critical load loss and improve the resilience of the entire DN during a typhoon crossing. Under the framework,

the mathematical model for the typhoon is firstly built, and a DN fault scenario formation method is proposed against the typhoon. Then an evolutionary Stackelberg game-based trading model is established to consider maximizing all stakeholders' economic benefits and reducing the load loss. In this model, critical loads (CLs) could reduce their load loss in typhoon weather, PLs could receive adequate compensation and rewards to stimulate them to participate in the trading, and distribution utility (DU) could ensure its economic benefits and enhance the DN resilience through the trading. A benefit allocation mechanism is proposed for all stakeholders to motivate all stakeholders to participate in the trading.

Contributions of this paper are as follows:

1. This paper proposes an emergent trading framework which can be used to supplement normal market under emergent or extreme situation, such as adverse event or extreme weather conditions. Under the framework, the PLs are stimulated to participate in the trading which could potentially help the CLs to decrease the loss, resulting in an increase of the DN resilience.
2. Further, an evolutionary Stackelberg game with three stakeholders is proposed for obtaining the evolutionary equilibria under the proposed emergent trading framework. Besides considering the economic benefits of the PLs and CLs, the proposed game includes a cost and benefit allocation mechanism to ensure more economic benefits for the DU than usual circumstances, thus motivating the DU to facilitate the trading.
3. The proposed framework considers the negative effect of free-riders on trading by applying the free-riding penalty.
4. Different distribution network topologies may result from faults at different locations and different periods. Thus, a formation method for the most likely fault scenarios based on the typhoon model and the information entropy constraint is proposed. Further, the resilience enhancement framework is based on selected scenarios.

The rest of this paper is organized as follows. In Section 2, the problem under study is described. The mathematical formulation is presented in Section 3. The solution algorithm is discussed in Section 4. The case study is provided in Section 5. Finally, Section 6 concludes the paper.

2 | PROBLEM DESCRIPTION

2.1 | Market-based resilience enhancement approach

The proposed framework contains three stakeholders: (1) CLs with load loss reduction requirements; (2) PLs with the capacity of providing fast response resources; (3) DU that serves the customers in the DN including CLs and PLs with resilience enhancement services through trading.

There are two sets of games existing in the trading process: (1) games between distinct stakeholders, including the game

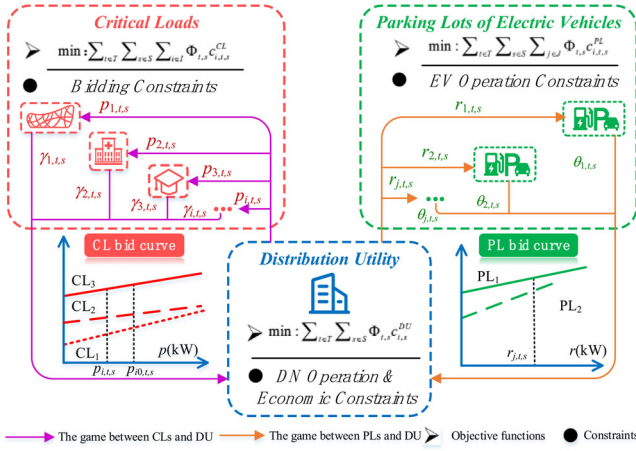

FIGURE 1 The trading framework of three stakeholders.

between CLs and DU, and the game between PLs and DU; (2) games among the same type of stakeholders, including the game between different CLs, and the game between different PLs.

The first set of games is a Stackelberg game, in which DU is the leader, and CLs and PLs are both followers. In the game between DU and CLs, DU firstly selects the strategy and then, CLs find their best response strategies to DU’s strategy. This is also true for the game between DU and PLs. Unlike the traditional Stackelberg game, this set of games in this paper will be iterated to equilibrium.

The second set of games is a non-cooperative and simultaneous game. Unlike the first type, there is no “leader”. All CLs involved in the trading, for example, wish to maximize their own interests. Players in this group have similar goals, yet due to limited information, this group behaves in a limited rational manner in terms of approaching the best strategy. Therefore, this paper uses evolutionary games to simulate such games, where both CLs and PLs can learn from the optimal strategies of individuals in their respective groups to adjust their strategies during the trading process.

Finally, to facilitate the participation of all the players to enhance the system resilience, a benefit allocation mechanism has been applied to the proposed framework. In short, the DU organizes the special emergent trading, called resilience enhancement services among the CLs and PLs with extra possibilities also to gain benefits (shared by CLs). To motivate the participation of the PLs, the DU provides awards to the EVs. By contrast, the DU charges an extra to the CLs for providing such an emergency service under adverse events. For the CLs, the economic benefits are from the reduced loss of load. The whole trading framework is as Figure 1.

2.2 | Impact of typhoon on the proposed approach

Faults at different locations in the DN may lead to an isolation of resources, which in turn may have an impact on

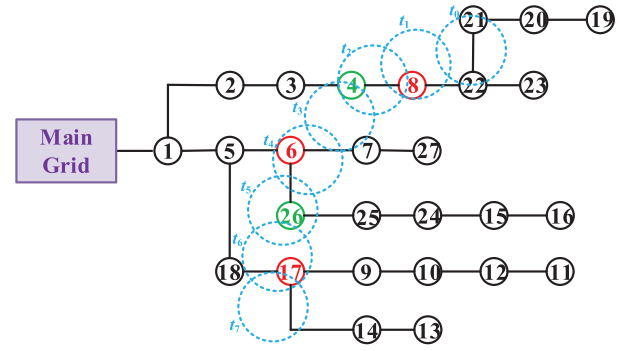

FIGURE 2 The influence of typhoon on the distribution network.

the trading. The following model is based on typical fault scenarios.

Usually, a typhoon model is built as a sequential trajectory circle model, indicating that the components with different locations in the system are at fault in different periods. As shown in Figure 2, red circles and green circles represent CLs and PLs respectively, blue circles represent the typhoon in different periods. For example, at time t_1 , node 8 is likely to be disconnected from the DN, which makes node 8 could not purchase resilience enhancement services. Similarly, at time t_5 , node 26, a PL, could not sell power if it is “isolated”.

In short, DN faults may physically “isolate” some loads or resources, thus they cannot participate in trading. Therefore, trading in different scenarios should be taken into consideration

2.3 | Typical fault scenarios considering typhoon

As mentioned earlier, the number and scale of “isolated” loads and resources vary under different fault scenarios. To accurately describe the faults caused by typhoon, this paper firstly models the typhoon, and analyses the impact of it on the probability of component faults. Then the most likely scenarios at each period are generated by Monte-Carlo simulation and selected by information entropy constraints, Section 3.1 describes the mathematical model in detail.

3 | PROBLEM FORMULATION

Before modelling, it should be noted that due to the length limitation, the following assumptions have been followed in the discussion of the problem in this paper:

1. The DN is deprived of power supply from the main grid.
2. The communication infrastructure and protection systems are still functional despite the typhoon, even with possible damages.
3. The typhoon only affects a part of the lines in the DN rather than damaging the entire grid.

3.1 | Typical fault scenarios modelling

3.1.1 | Component fault rate considering typhoon

Taking a typical extreme weather typhoon as an example, this paper firstly analyses the impact of the typhoon on the fault rate of DN components, and secondly selects the set of fault scenarios according to the information entropy constraint.

The typhoon wind field model can be described by (1), according to [28].

$$v_{c,t} = \begin{cases} V_{R_{typh}} r_{c,t} / R_{typh}, & r_{c,t} \leq R_{typh} \\ V_{R_{typh}} (R_{typh} / r_{c,t})^{0.7}, & r_{c,t} > R_{typh} \end{cases} \quad (1)$$

Typhoon is not stationary in practice, it moves on a certain trajectory, and its speed is (2).

$$V_{move} = e^{(A+B \cdot randC)} \quad (2)$$

Therefore, the distance of the component from the typhoon centre also varies with time, at time t there is:

$$r_{c,t} = \sqrt{Z_c^2 + \left(\sqrt{r_{c,0}^2 - Z_c^2} - V_{move} t \right)^2} \quad (3)$$

Transmission lines consist of conductors and towers, and only when both are operating properly at the same time transmission lines do not fail, and under the influence of the typhoon, the fault rate can be calculated as (4) [29].

$$\begin{cases} \lambda_{con} = \int_0^{\sigma_{con}} \frac{1}{\sqrt{2\pi} S_{con}} \exp \left[-\frac{1}{2} \left(\frac{\bar{\sigma}_{con} - \mu_{con}}{S_{con}} \right)^2 \right] d\bar{\sigma}_{con} \\ \lambda_{tow} = \int_0^{\tau_{tow}} \frac{1}{\sqrt{2\pi} S_{tow}} \exp \left[-\frac{1}{2} \left(\frac{\bar{\tau}_{tow} - \mu_{tow}}{S_{tow}} \right)^2 \right] d\bar{\tau}_{tow} \end{cases} \quad (4)$$

The stress received by the conductor and the bending moment applied to the tower is as (5).

$$\begin{cases} \sigma_{con} = 2(L_{typh,con} + L_g) R_{con} \\ \tau_{tow} = \sqrt{L_{typh,tow}^2 + L_{typh,con}^2} H_{tow} \end{cases} \quad (5)$$

The wind load exerted on the components by a typhoon can be expressed as (6).

$$L_{typh,c} = 0.75 v_{c,t}^2 R_c \sin^2 \omega_c, \quad con, tow \in c \quad (6)$$

Thus, the distribution line fault rate can be calculated. For example, assuming that c_{7-27} in Figure 2 consists of M conductors and N towers, the probability of failure of c_{7-27} is as (7).

$$\lambda_{c_{7-27,t}} = 1 - \prod_{m \in M} (1 - \lambda_{con,m}) \cdot \prod_{n \in N} (1 - \lambda_{tow,n}) \quad (7)$$

3.2 | Typical fault scenario modelling

A large number of components in the DN makes it necessary to choose scenarios according to the likelihood and uncertainty of their occurrence. Defining the entropy of the DN as (8).

$$E_{DN,t} = \sum_{c \in C} (-\log_2 \lambda_{c,t}) q_{c,t} \quad (8)$$

In this way, typical fault scenarios can be selected based on the actual probability of component fault, and these scenarios must meet the following constraint.

This paper assumes that after a certain period the line fault may be repaired, there is (9).

$$q_{c,t+1} = \xi_c (1 - q_{c,t}), \quad \text{if } q_{c,t} = 0 \quad (9)$$

Finally, the selection of scenarios needs to be constrained by (10).

$$E_t^{\min} \leq E_t^{DN} \leq E_t^{\max}, \quad t \in T \quad (10)$$

3.3 | “CL-DU-PL” trading model based on game theory

In this part, this paper constructs three models for three stakeholders respectively, as they have different objective functions and constraints.

3.3.1 | Model of critical loads

The objective function of CL_i is (11).

$$\min : \sum_{t \in T} \sum_{s \in S_t} \sum_{i \in I} \Phi_{t,s}^{CL} \quad (11)$$

where $c_{i,t,s}^{CL}$ is defined as (12).

$$\begin{aligned} c_{i,t,s}^{CL} = & c_i^{loss}(p_{i,t,s}) + \alpha_i (c_i^{loss}(p_{i0,t,s}) - c_i^{loss}(p_{i,t,s})) \\ & + \delta_i^0 \cdot c_i^{buy} + \sum_{k=1} \delta_{i-k}^{k-buy} c_{i-k} \end{aligned} \quad (12)$$

where $c_i^{loss}(p_{i,t,s})$ is the actual damage function; the second term is the extra payment to the DU, which is a portion of the economic benefit that a CL_i obtains by purchasing resilient service to reduce his/her load loss; the third term is the self-supporting part of the resource purchase cost; the fourth term

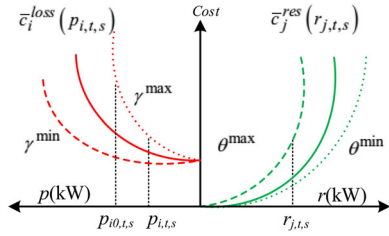

FIGURE 3 Critical load damage function and resource provision cost function.

is the resource purchase cost that CL_i should pay for upstream users. Obviously, the third and fourth terms are related to the free-riding penalty coefficient (Refer to Figure 4).

$c_i^{loss}(p_{i,t,s})$ is further expressed as a quadratic function with the variable $p_{i,t,s}$, as (13) shown.

$$c_i^{loss}(p_{i,t,s}) = D_i \cdot (p_{i,t,s})^2 + E_i \cdot p_{i,t,s} + F_i \quad (13)$$

For gaining more benefits in the game with DU, CL_i usually corrects the damage function according to its attributes and willingness when submitting it to DU. In reference [30], Shahidehpour et al. proposes a method to describe this behaviour. He believes that loads can modify the linear term coefficients to “trick” DU about their load importance. This paper adopts the same principle, and the Equation (13) can be replaced by (14) in the game. Therefore, $\gamma_{i,t,s}$ can be seen as the game strategy of CL_i

$$c_i^{loss}(p_{i,t,s}) = D_i \cdot (p_{i,t,s})^2 + \gamma_{i,t,s} \cdot p_{i,t,s} + F_i \quad (14)$$

The game between CL_i and DU is a Stackelberg game, DU is the leader and CLs are followers. When a typhoon comes, DU firstly proclaims the load loss of each CL ($p_{i0,t,s}$) according to its load importance, then CLs respond with their strategies based on the published information, lastly, DU decides its strategies with each CL ($p_{i,t,s}$). The above process is a single complete game process, which in practice may be repeated several times for reaching the equilibrium point.

To better describe the strategic equilibrium process of the CL cluster, this paper employs the evolutionary game is used to describe the strategy modification process of CLs, and the specific formula is given in Section 4.

The bid curve of CL_i can be obtained by differentiating the revised damage function, as shown in Figure 3.

The resilience enhancement service cost is similar to electricity purchase, as (15).

$$c_{i,t,s}^{buy} = P_{buy} \cdot (p_{i0,t,s} - p_{i,t,s}) \quad (15)$$

In fact, this cost is only partly borne by CL_i and partly by the downstream users.

Definition 1. : The node’s location is defined as downstream in the direction in which the power flow leaves the reference

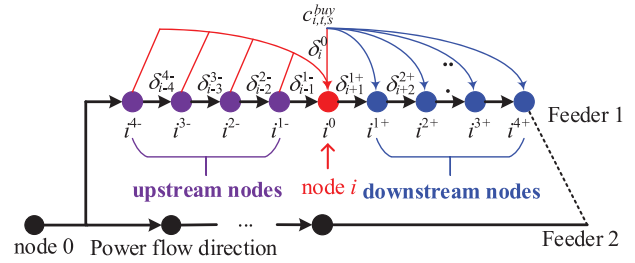

FIGURE 4 Definition of the free-riding.

node. Free-riders in this paper are defined only on the set of downstream nodes. With node i as the reference node, the k th downstream node i is the free-rider i^{k+} , and the portion of the service purchase cost that should be allocated to this free-rider is $\delta_i^{k+} \cdot c_{i,t,s}^{buy}$, δ_i^{k+} is defined as the free-riding penalty coefficient.

For example, in Figure 4, node i must share the service purchase cost from all his/her upstream nodes, in the figure are respectively i^{4-} to i^{1-} , while allocating its service purchase cost to all downstream nodes. The penalty suffered by node i due to free-riding is

$$\sum_{k=1}^4 \delta_{i-k}^{k-} c_{i-k}^{buy} \quad (16)$$

However, it should be noted that as node i could allocate $1 - \sum_{k=1}^4 \delta_i^{k+}$ (defined as δ_i^0) to his/her downstream nodes. Thus, the self-supporting part of the service purchase cost is only $\delta_i^0 \cdot c_i^{buy}$ (Refer to (12)).

A trading judgment indicator is established using the difference in load loss before and after CL_i participant in the trading.

$$I_i = \frac{|p_{i0,t,s} - p_{i,t,s}|}{p_{i0,t,s}} \quad (17)$$

The DN resilience enhancement index could be constructed by index RI_{DN} [9], $E[\cdot]$ means expected parameter .

$$RI_{DN} = \sum_{i \in I} \Phi_{t,s} E [p_{i,t,s}] \quad (18)$$

Constraints are as follows.

$$\gamma_i \in \{\gamma\} \quad (19)$$

$$c_{i,t,s}^{CL} \leq c_i^{loss}(p_{i0,t,s}) - c_i^{loss}(p_{i,t,s}) \quad (20)$$

Equation (19) indicates rational bidding by CL_i ; Equation (20) constrains the economic interests.

3.3.2 | Model of parking lots

The objective function of PL_j is (21).

$$\min : \sum_{t \in T} \sum_{s \in S_t} \sum_{i \in J} \Phi_{t,s} c_{j,t,s}^{PL} \quad (21)$$

$c_{j,t,s}^{PL}$ could be written as (22) in detail. The first term of the right side is the actual resource cost function; the second term is the reward to incentive PL_j to participant in the trading offered by DU; the last term is the revenue from the sale of its power.

$$c_{j,t,s}^{PL} = c_j^{res}(r_{j,t,s}) - \beta_j \left(\bar{c}_j^{res}(r_{j,t,s}) \right) - b_{j,t,s}^{sell} \quad (22)$$

The resource cost function also can be simplified to a quadratic function, as the marginal generation cost.

$$\bar{c}_j^{res}(r_{j,t,s}) = G_j(r_{j,t,s})^2 + H_j \cdot r_{j,t,s} \quad (23)$$

When submitting this function to DU, similar to the CL side, PL_j also modifies this function. Here again, in this paper, this process is described by varying the primary term coefficient.

Also, there is a Stackelberg game existing, the leader is DU, and followers are PLs. Since the entire PL cluster tends to end up with a consistent strategy in order to sell more power, the evaluation game is also applied, similar to CL side.

$$\bar{c}_j^{res}(r_{j,t,s}) = G_j(r_{j,t,s})^2 + \theta_j \cdot r_{j,t,s} \quad (24)$$

Unlike (14), there is no constant term in (24). The bid curve can be obtained by differentiating (24).

PL_j is able to generate benefits by selling power, as (25).

$$b_{j,t,s}^{sell} = P_{sell} \cdot r_{j,t,s} \quad (25)$$

Constraints [31]:

$$\sum_{i \in L_j} r_{i,j,t,s} = r_{l,j,t,s} \quad (26)$$

$$SOC_{l,j,t} = SOC_{l,j,t-1} + \Delta t \left(R_{l,j}^C \eta_{l,j}^C - R_{l,j}^D / \eta_{l,j}^D \right) \quad (27)$$

$$SOC_{l,j}^{\min} \cdot u_j \leq SOC_{l,j}^t \leq SOC_{l,j}^{\max} \cdot u_j \quad (28)$$

$$\begin{cases} 0 \leq R_{l,j}^C \leq R_{l,j}^{C,\max} \cdot u_j \\ 0 \leq R_{l,j}^D \leq R_{l,j}^{D,\max} \cdot u_j \end{cases} \quad (29)$$

$$R_{l,j}^C \cdot R_{l,j}^D = 0 \quad (30)$$

$$\sum_{j \in J} \sum_{i \in L_j} R_{i,j}^C \geq \sum_{j \in J} \sum_{i \in L_j} R_{i,j}^D \quad (31)$$

$$\sum_{j \in J} N_j = N_j^{\max} \quad (32)$$

$$\sum_{i \in L_j} N_{i,j} = N_{l,j}^{\max} \cdot u_j \quad (33)$$

$$N_{l,j} = V_j^{\max} \cdot u_j \quad (34)$$

$$\theta_j \in \{\theta\} \quad (35)$$

Equation (26) means EVs in the PL decide on the resource provision capacity. Equations (27)–(31) restraint the charging and discharging behaviour of EVs in emergencies. Equations (32)–(34) restraint the available PLs in contingency conditions. Equation (32) ensures that all PLs can provide charge and discharge support for the EVs in the system under all circumstances, Equation (33) constraints that all EVs should enter PL in emergencies, Equation (34) is utilized to limit the number of EVs in the PL. Equation (35) then constrains the bidding strategy of PL_j .

3.3.3 | Model of distribution utility

The objective function of DU is (36).

$$\min : \sum_{t \in T} \sum_{s \in S_t} \Phi_{t,s} c_{t,s}^{DU} \quad (36)$$

DU receives a portion of the revenue from CLs and spends a portion of the cost on PLs. And earned the difference from the trading process.

$$\begin{aligned} c_{t,s}^{DU} = & \sum_{j \in J} \left(\beta_j \left(\bar{c}_j^{res}(r_{j,t,s}) \right) + B_{j,t,s}^{sell} \right) \\ & - \sum_{i \in I} \left(\alpha_i \left(\bar{c}_i^{loss}(p_{i,t,s}) - \bar{c}_i^{loss}(p_{i0,t,s}) \right) + c_i^{buy} \right) \end{aligned} \quad (37)$$

Constraints:

$$\begin{cases} U_i^{\min} \leq U_{i,t,s} \leq U_i^{\max} \\ U_j^{\min} \leq U_{j,t,s} \leq U_j^{\max} \end{cases} \quad (38)$$

$$\sum_{i \in I} (p_{i0,t,s} - p_{i,t,s}) \leq \sum_{j \in J} r_{j,t,s} \quad (39)$$

$$c_{t,s}^{DU} \leq c^{DU,\min} \quad (40)$$

Equation (38) is DN voltage constraint; Equation (39) is DN power constraint; Equation (40) ensures minimum profits for DU, in such a circumstance, DU must secure its economic interests before facilitating a deal. But for other benefit-neutral stakeholders such as DSO, have no profits.

ALGORITHM 1 Solution of the proposed model.

- 1: **Step 1** Set the iteration counter $ic = 1$ and the maximum number of iterations IC , respectively.
- 2: **Step 2** Generate typical fault scenarios based on the predicted typhoon track, then input fixed parameters and initialized $\gamma_{i,t,s}, \theta_{j,t,s}, P_{i,t,s}, r_{j,t,s}$
- 3: **Step 3** Do for $t = 1, 2, \dots$
- 4: **Step 3.1** Calculate CLs and PLs objective functions based on the initial parameters, and update evolutionary game strategies according to (42) and (43).
- 5: **Step 3.2** Determine whether the evolutionary games have reached equilibrium: $Yes = \text{Step 3.3}$, $No = \text{Step 3.1}$.
- 6: **Step 3.3** Solve the DU model with the final strategies in **step 3.2** as the initial variables.
- 7: **Step 3.4** Determine whether the Stackelberg games have reached equilibrium: $Yes = \text{Step 4}$, $No = \text{Step 3.1}$.
- 8: **Step 4** Set $ic = ic + 1$. If $ic \leq IC$ go to **Step 3**, else go to **Step 5**.
- 9: **Step 5** Output final results.

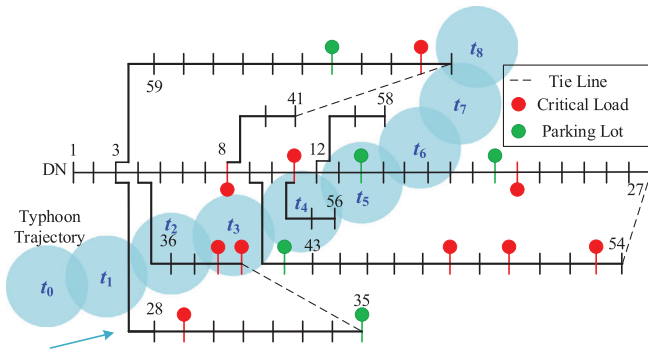
**FIGURE 5** Modified IEEE 69 node system and the typhoon trajectory.

4 | SOLUTION OF THE PROPOSED MODEL

The games presented in Section 3 are of pure strategy. As the equilibrium of an evolutionary game is a Nash Equilibrium under pure strategy [32]; this paper first calculates CLs and PLs' evolutionary game equilibrium, then corresponding strategies of them are used as the initial strategies to calculate the equilibrium of the Stackelberg game. If convergence is achieved, the equilibrium of the evolutionary game and the Stackelberg game is proved. The proposed solution is shown in Algorithm 1.

If the set of strategies selected by a user group is O , define users cluster (CLs or PLs) in this group that chooses strategy y as x_y , the whole group utility function is $c_{y,t,s}$ in scenario s at time t when choosing strategy y . x_y could switch to strategy z when the utility is better, according to (41).

The first term of the right side of (41) is the portion of users who choose other strategies to change to strategy z , the second term is the portion of users who choose strategy z to change to

TABLE 1 Critical load parameters.

CL	Node	Load (kW)	Quality		
			D_i	E_i	F_i
1	8	70	0.02	2	200
2	11	145	0.02	3	400
3	21	110	0.02	3	400
4	29	80	0.01	2	200
5	38	380	0.03	5	300
6	39	380	0.03	5	300
7	48	100	0.02	3	400
8	50	600	0.04	4	400
9	53	200	0.03	4	300
10	68	80	0.02	2	200

other strategies.

$$\frac{\partial x_{y \rightarrow z}}{\partial t} = \sum_{z \in O} x_z \rho_{yz} - x_y \sum_{z \in O} \rho_{zy} \quad (41)$$

Switching velocity is as (42).

$$\rho_{yz} = \frac{\exp(c_{y,t,s})}{\sum_{z \in O} \exp(c_{z,t,s})} \quad (42)$$

5 | CASE STUDY

5.1 | IEEE 69-bus system

5.1.1 | Background data

The modified IEEE 69-bus distribution test system is employed to implement the proposed model [33], as Figure 5. The system contains a single feeder with 7 side branches. There are 10 CLs and 5 PLs in the grid. $A = 2.34$, $B = 0.7$. The trajectory of the typhoon is shown as the blue circle in Figure 5, the time interval between t_0 and t_1 is one hour, constant $A = 2.34$, $B = 0.7$, $randC$ is a random number that matches the standard normal distribution. The duration between two trading in the case study is setting as 30 min, $\xi_c = 1$. For other mechanical parameters of the distribution line, refer to [29].

The maximum and minimum SOC values of the battery of EVs are assumed to be 90% and 10%, respectively, while the nominal capacity of batteries considered to be 40 kWh, the rated charge and discharge capacity of the EVs are considered as 10 kW, the maximum and minimum SOC values of the battery of EVs are assumed to be 90% and 10%, while the charge/discharge efficiency is 85%. And each PL is the equivalent of several adjacent PLs with 30 empty parking spaces. The setting of CLs is shown in Table 1.

Node 65, node 14, node 20, node 42, and node 35 are setting as PL_1 to PL_5 . $G_j = 0.001$, $H_j = 2$.

TABLE 2 Scenarios for base case.

Time	Fault line	Occurrence probability
t_0	None	/
t_1	3–28	0.16
t_2	3–28, 4–36, 37–38	0.19
t_3	37–38, 38–38, 35–39, 9–42	0.22
t_4	9–42, 11–12, 55–56	0.12
t_5	12–13, 16–17	0.14
t_6	15–16, 16–17, 17–18	0.20
t_7	41–69	0.08
t_8	41–69, 68–69	0.13

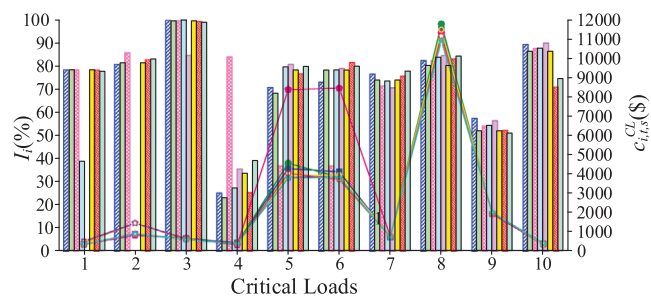

FIGURE 6 Trading results of CLs.

P_{buy} is setting as 0.5\$/kW, and P_{sell} is setting as 0.3\$/kW. For the free-riding level, only the first three free-riding levels are counted.

5.1.2 | Base case

In this case, we first calculate all distribution line fault rates in the test system when the typhoon passes by, then fault scenarios are generated from the fault rate. In the simulation result, more than 85% of the scenario's entropy values are in (5, 25). Thus, E^{\min}/E^{\max} are respectively setting as 5/25. To illustrate our proposed approach more clearly, only the most likely scenarios for each time period are selected in this case, and the scenarios used in this case are shown in Table 2.

Based on these scenarios, trading results are calculated for demonstrating the validity of the proposed model, as Figures 6 and 7 shown (α_i and β_j are both setting as 0.5). For the aesthetics of the picture, we use absolute value to make figures for negative objective function values, such as $|c_{j,t,s}^{PL}|$ in Figure 7, and $|c_{i,t,s}^{DU}|$ in Figure 8.

Figure 6 could partially demonstrate the validity of the proposed approach, the load loss of CLs can be effectively reduced in almost all scenarios, except when they are isolated. For example, CL₁ could reduce load loss by nearly 80% in t_1 , t_2 , t_3 , t_6 , t_7 , and t_8 , but at t_4 it can only be reduced by 40%, at t_5 it even cannot reduce any loss. In fact, these anomalies occur at t_4 and t_5 are the results of different network topologies. At time t_4 , the

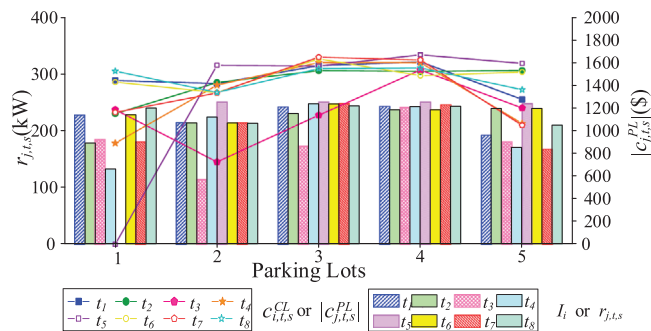

FIGURE 7 Trading results of PLs.

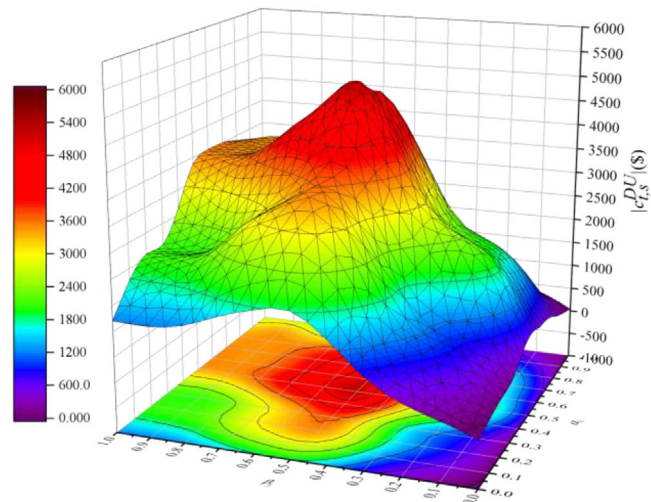

FIGURE 8 Benefit curve of DU.

distribution line breaks between CL₁ and PL₁, but due to the superior location of CL₁ itself, it still could gain a small amount of power supply from other PLs. However, PL₁ is isolated at t_5 , there are not enough resources in the DN and CL₁ cannot get any resilient services because it is not “critical” enough. Another example is CL₅, its load loss varies nearly twice in different scenarios (\$8381.98 at t_3 , \$3738.30 at t_8), however, it still can reduce the load loss by 37% even at t_3 , this type of loads could bring more benefits to DU due to their own attributes, thus, they are considered more “critical” by DU in the trading, that is, DU will try to minimize their load loss first. In addition, free-riders do get punished in the trading. As neighbours of the most important load CL₈ in the DN, CL₇ and CL₉ could pay less to reduce their load loss, but even then a large part of their cost is free-riding penalties, more details can be seen from figures in Case 2.

Figure 7 has shown the trading results of PLs in the chosen scenarios. In general, due to the limited total amount of resources in the DN, there is no strong competition among PLs. As long as PLs are not isolated, they can gain good economic benefits by participating in the resilience enhancement service. Take PL₁ as an example, from t_2 to t_5 , the typhoon has a notable impact on PL₁. As the typhoon gradually approaches, the amount of power sold and the benefits obtained by PL₁

TABLE 3 Resilience index before and after trading.

Time	Resilience index RI_{DN} (kW)	
	Before trading	After trading
t_1	246.96	86.44
t_2	314.64	106.02
t_3	364.32	168.43
t_4	198.72	75.56
t_5	231.84	92.26
t_6	331.20	102.22
t_7	132.48	40.30
t_8	215.28	61.94

decrease. For other PLs, such as PL_4 , the typhoon has few impacts on it, and its trading results in these scenarios are virtually unchanged.

Table 3 shows the resilience index before and after the trading, it can be seen easily that the resilience of DN has improved greatly after the trading.

The Base Case demonstrates that the market-based approach proposed in this paper can reduce the load loss in emergencies, improve the economic benefits of the three stakeholders, and fully consider the impact of different faults on the trading process. In the next cases, the scenario t_8 at in base case is chosen for further study on the economic cost/benefit of the three stakeholders.

5.1.3 | Case 1: DU economic analysis

This case focuses on the impact of the benefit allocation coefficients (α_i / β_j) on DU's economic benefits. We change these two coefficients from 0 to 1 and calculate the objective function value of DU, results are shown in Figure 8.

In fact, there are 6 wave crests in the curve in Figure 8, but there is only one maximum point. This means that DU can adjust these two coefficients before trading to maximize its own profit. Likewise, DU can also adjust these two coefficients to reduce its own interests to make other subjects more profitable, thus increasing their willingness to participate in the trading, while it only reaches the optimum in a certain interval. In some practical circumstances, this approach is very flexible and effective. Decreasing α_i means CLs could pay less to buy the resilience enhancement service, and increasing β_j means PLs could gain more from the trading, this is important for individuals who focus on their benefits.

Figure 9 is a further refinement of Figure 8, which is two tangent lines from Figure 8. The locations of the six crests have been marked in the figure by circles, and five of them are included on the chosen tangent lines. A wave crest means an extreme point within a small interval, and the point ($\alpha_i = 0.5$, $\beta_j = 0.5$) is the maximum point of all wave crests, more wave crests imply more flexibility. For example, when $\alpha_i = 0.5$ and β_j changes, there are three extreme points on the corresponding

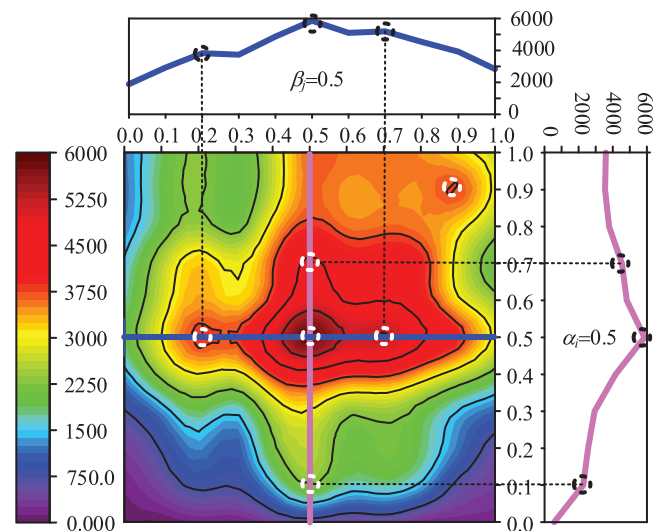
**FIGURE 9** Hotspot projection and tangent lines of DU ($\alpha_i = 0.5/\beta_j = 0.5$).

tangent (refer to the sub-figure $\alpha_i = 0.5$), respectively corresponding $\beta_j = 0.1$, $\beta_j = 0.5$, and $\beta_j = 0.7$. The primary goal of DU is to maximize its benefits, and the secondary goal is to facilitate trading. However, these two goals may conflict in some situations, the other two stakeholders also require adequate economic benefits, DU may need to sacrifice a part of its own interests at this point, and this benefit allocation mechanism gives it more flexibility to deal with this situation. For other benefit-neutral stakeholders, this mechanism also makes it easier to achieve their goals.

In short, successful trading requires a balance between the economic interests of all three stakeholders, and this benefit allocation mechanism is designed to do just that, bringing greater flexibility to the trading and making the trading results more controllable.

However, DU is not the only one affected by these two coefficients (α_i / β_j), CLs/PLs are also affected by α_i / β_j , and their bidding strategies will change when these two coefficients change. Thus, in the next case, the impact of the benefit allocation mechanism on CLs/PLs will be studied.

5.1.4 | Case 2: CLs and PLs economic analysis

This case is also running in the same scenario as Case 1 (t_8). Figures 10 and 11 are the economic analysis about CLs when the benefit allocation coefficient α_i changes, Figure 12 is the economic analysis about PLs when the benefit allocation coefficient β_j changes.

Figures 10 and 11 are respectively the economic composition of CL_1 and CL_2 when α_i changes, and their bidding strategies are also can be seen in figures. In general, as α_i increasing from 0 to 1, the bidding strategies and the objective function value show a decreasing and then increasing trend, and a few fluctuations appear in the process. It is specified that when $\alpha_i = 0$ or $\beta_j = 0$, the corresponding CL or PL will not participate in

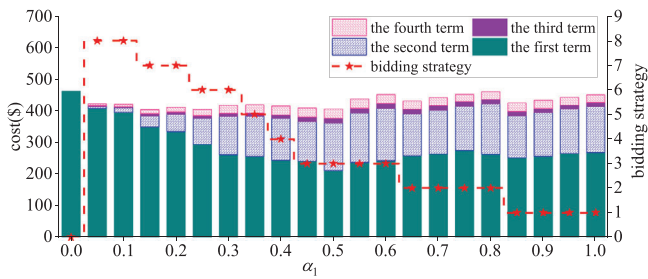

FIGURE 10 Economic composition of CL1 when α_i changes.

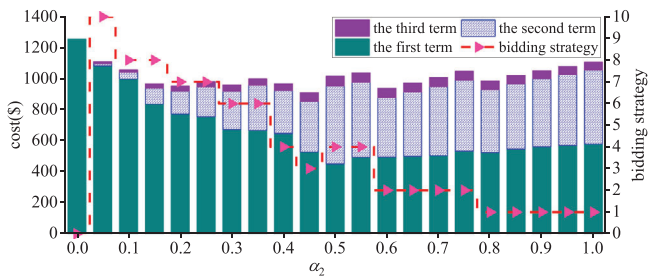

FIGURE 11 Economic composition of CL2 when α_i changes.

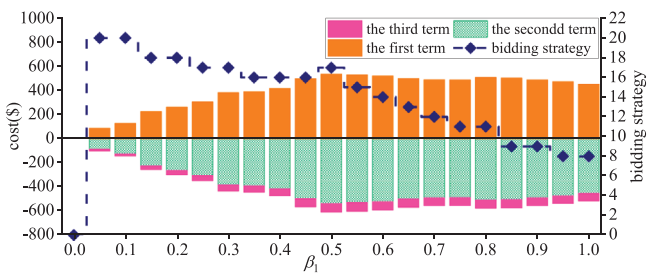

FIGURE 12 Economic composition of PL₁ when β_j changes.

the trading. Taking CL₁ as an example, it can be seen that the objective function of CL₁ consists of four parts, and the penalty of free-riding (the fourth term) accounts for about 10% of its total cost. It is worth noting that CL₁'s total cost reduction due to participation in the trading is less than 20% (at t_8 , from 452.5\$ to 390.4\$), the impact of the free-riding penalty makes the cost reduction not obvious. To some extent, this can partly prove the effectiveness of the penalty measures proposed in this paper.

The model proposed in this paper places more emphasis on large loads in the trading, large loads are usually more "critical". Prioritizing large loads not only can obtain more economic benefits, but also leads to more significant resilience improvement of the DN. For example, CL₂ could reduce its cost up to 304\$ at t_8 , which is four times CL₁. Part of the reason is because of the parameter settings, but the main reason is the load volume gap (CL₂ is 145 kW, CL₁ is 70 kW). And since only the first three free-riding levels are calculated in the example, CL₂ does not bear the free-riding cost. The larger load could reduce greater load loss in the trading, for CL₈, it even could reduce hundreds of dollars at on period, this is another reason for incentivizing

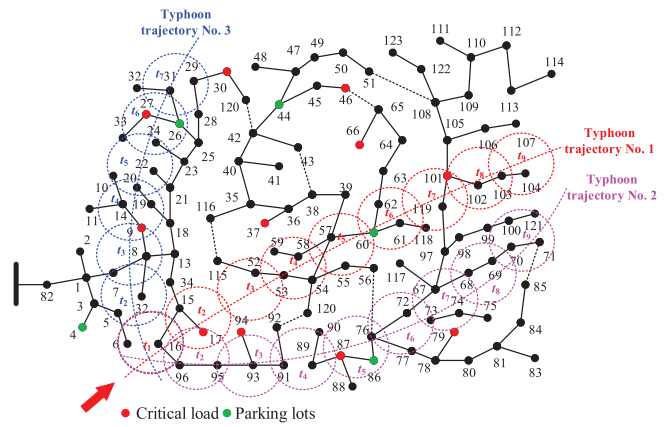

FIGURE 13 IEEE 123-bus system.

the large critical loads to participate in the trading to reduce their load loss.

Different from the CL side, the economic composition curve and bidding strategy show some similarities of all non-isolated CLs, thus here only PL₁ is chosen to illustrate. Figure 12 shows the simulation results, the economic benefits of CL₁ first increase and then levels off with β_j increases. The reason for the similarity is maybe the resources in the DN are not sufficient, only all PLs that reach the capacity limit can satisfy the power demand of CLs, thus there is no apparent competitive behaviour between PLs. However, the situation becomes distinct when there are sufficient resources in the DN. Well-located PLs sell power more easily and gain more interests, and poorly-located PLs have to lower their bidding strategies. In short, the adequacy of resources in the DN affects the interests of PLs.

5.2 | IEEE 123-bus system

To demonstrate the practical application and scalability of the proposed framework, a modified IEEE 123-bus test system is employed to test. The original topology has the disconnected lines 16–96, 92–120, 115–116, 42–120, 38–43, 39–57, 56–76, 46–65, 51–108, and 71–85. The lines 16–96, 92–120, 56–76, 39–57, 38–43, 42–120, 46–65, 51–108, 71–85, 52–53, 60–57, 60–117, 101–119, 63–64, and 67–117 are dispatchable. Figure 13 shows the topology and the trajectory of the typhoon. And other data about CL and PL can be found in [35].

5.2.1 | Base case

Table 4 illustrates the resilience index before and after trading under three different typhoon trajectories. Obviously, with the proposed trading framework, the resilience index under each trajectory has dramatically dropped after trading. Thus, the proposed trading framework can be applied effectively under different typhoon trajectories rather than a defined one.

TABLE 4 Resilience index under different typhoon trajectories.

Time	Resilience index RI_{DN} (kW)					
	Before trading under different typhoon trajectories			After trading under different typhoon trajectories		
	No. 1	No. 2	No. 3	No. 1	No. 2	No. 3
t_1	209.86	209.86	209.86	49.34	49.34	49.34
t_2	266.12	224.64	201.69	57.51	55.56	49.50
t_3	242.57	258.74	263.05	46.68	50.88	55.87
t_4	174.12	254.28	249.14	50.96	49.67	50.69
t_5	209.50	198.17	161.07	69.92	69.23	47.12
t_6	298.90	186.93	215.98	69.92	49.56	68.34
t_7	138.19	282.45	274.08	46.01	55.45	53.68
t_8	196.85	142.57	/	43.51	51.56	/
t_9	180.93	202.28	/	45.83	54.57	/

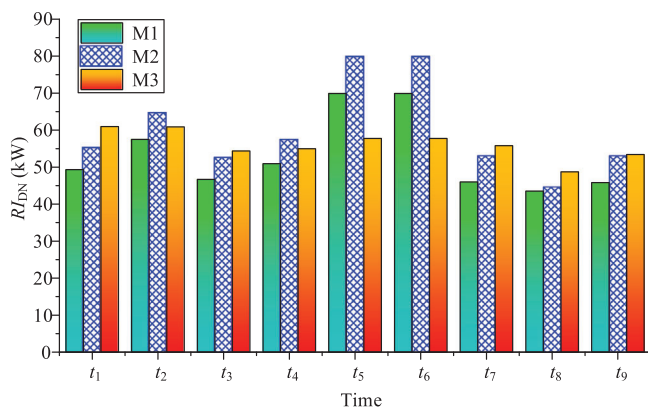
**FIGURE 14** Resilience index compared with two other methods.

5.2.2 | Economic comparison

Under the trajectory no. 1, RI_{DN} is compared after applying different methods. As shown in Figure 14, M1 is the proposed method, M2 is the CL restoration method in [36], and M3 is the DN reconfiguration strategy in [35]. A smaller RI_{DN} means better resilience enhancement. It is obvious that the method proposed in this paper is the best when all periods are considered. Admittedly, at t_5 and t_6 , the resilience enhancement of M1 is not as effective as M3, because node 60 is isolated at this point.

Then, the economics of the three methods are compared. As can be seen from Table 5, there is no doubt that the M1 has a dominant advantage in the economy.

5.2.3 | Algorithm convergence and solution time

Figure 15 gives the iterations of the solution method in different test systems. Obviously, as system size increases, the number of iterations in one period becomes larger. Obviously, the com-

TABLE 5 Economics comparison with two other methods.

Time	Cost (\$)		
	M1	M2	M3
t_1	510.11	729.01	1000–1400/period
t_2	555.12	852.82	
t_3	496.07	693.35	
t_4	518.83	757.97	
t_5	629.16	1052.26	
t_6	629.16	1052.26	
t_7	492.58	699.15	
t_8	479.76	588.07	
t_9	491.65	699.14	

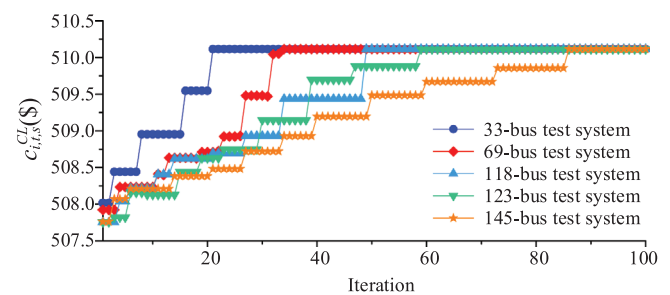
**FIGURE 15** The convergence of the solution method in different test systems.**TABLE 6** Computation time in different test systems.

Test system	Typical fault scenarios computation time (min)	Trading computation time	
		Total time (s)	Number of iterations
IEEE 33-bus test system	4.14	5.268	21
IEEE 69-bus test system	7.11	9.046	34
IEEE 118-bus test system	8.58	16.017	49
IEEE 123-bus test system	9.56	23.334	59
IEEE 145-bus test system	15.99	30.791	86

plexity of the system structure will significantly increase the number of iterations.

Table 6 shows the total computation time of the proposed framework under different test systems. The total computation time consists of two parts, the typical failure scenario calculation, and the emergency trading calculation. It can be seen that the typical fault scenarios calculation takes up most of the time, due to the application of Monte-Carlo simulation. In contrast, the time spent on trading computation is negligible.

6 | CONCLUSION AND FUTURE WORKS

This paper proposes an emergent trading framework for using parking lots as fast recovery resources to reduce critical load loss and improve the resilience of the entire DN after a typhoon crossing. Under the proposed framework, a mathematical model for the typhoon is built, and a DN fault scenario formation method is proposed. Then an evolutionary Stackelberg game-based trading model is established to consider maximizing all stakeholders' economic benefits and reducing the load loss. Further, a benefit allocation mechanism and free-riding penalty are introduced in the framework to make it easier to the goal and limit the negative effect of free-riders, with an iterative evolutionary-Stackelberg solution set-up is applied to illustrate the solution of the proposed model. Case studies demonstrate that the proposed framework could reduce critical load loss, and in consequence to improve system resilience. The simulation results also show that by adjusting different parameters related to the benefit allocation mechanism, the proposed framework can be effectively applied to a large range of severity of emergencies.

It should be noted that the current framework considers the free-riding behaviour during the emergency trading in a simplified way and cannot fully prevent the negative effect. Therefore, our next step is to further refine the model of free-riding. In addition, the EVs are currently presented by PLs, a finer model of stakeholders such as EV owners will be extended in the future.

NOMENCLATURE

Sets and Indexes

- $i/j/l$ Index for CL/PL/EV, $i \in I, j \in J, l \in L_j \in \{1, 2, \dots\}$
- s Index for scenario, $s \in S_s = \{1, 2, \dots\}$
- t Index for time, $t \in T = \{1, 2, \dots\}$
- $\{\gamma\}/\{\theta\}$ Set of CL/PL bidding strategy
- c Index for distribution line, $c \in C = \{1, 2, \dots\}$

Superscript and Subscript

- \bullet_c Corresponding parameter \bullet of distribution line, including tower (*ton*) and conductor (*con*)
- \bullet_t Corresponding \bullet parameter at time t
- \bullet_{tpb} Corresponding \bullet parameter of typhoon
- \bullet_i/\bullet_j Corresponding parameter \bullet of CL_{*i*}/PL_{*j*}
- \bullet_{lj} Corresponding parameter \bullet of Electric vehicle l in PL_{*j*}
- $\bullet_{t,s}$ Corresponding parameter \bullet in scenario s at time t
- $\bullet_{\min}/\bullet_{\max}$ Maximum/minimum (limits) of corresponding quantity \bullet
- \bullet^C/\bullet^D Parameter \bullet in charge/discharge situation

Parameters

- V Speed of typhoon
- R Radius

- Z Vertical distance from the typhoon center
- $A, B, randC$ Typhoon-related constants
- S Component strength standard deviation
- μ Component strength average
- σ/τ Stress/bending moment
- $\bar{\sigma}/\bar{\tau}$ Average stress/bending moment
- L Force load
- H Height
- ω Angle of wind direction and component
- ξ Recovery rate
- E Information entropy
- $c^{CL}/c^{PL}/c^{DU}$ Objective function of CL/PL/DU
- Φ Occurrence probability
- α/β Benefit allocation coefficient
- D, E, F Constants related to CL
- c^{loss} The damage function
- p_{i0} Load loss before purchasing power
- I Evaluation Indicator
- RI Resilience Index
- \bar{c}^{loss} The revised damage function
- c^{buy} Power purchase cost
- δ Free-riding penalty coefficient
- P_{buy}/P_{sell} Price of buying/selling power
- c^{res} The resource cost function
- \bar{c}^{res} The revised resource cost function
- Benefit allocation coefficient
- b^{sell} Benefits of selling power
- G, H Constants related to PL
- SOC State of charge
- R Power of charging or discharging
- η Efficiency
- N Number
- V Capacity
- U Voltage

Variables

- v Wind speed
- r Distance from typhoon center
- λ Fault rate
- q Binary variable of distribution line (1 = fault, 0 = otherwise)
- p Expected load loss
- γ CL bidding strategy
- r Expected power selling
- θ PL bidding strategy
- u Binary variable of the status of PL_{*j*} (1 = installed, 0 = otherwise)

AUTHOR CONTRIBUTIONS

Yingjun Wu: Conceptualization, Methodology, Supervision, Writing – review and editing; Chengjun Liu: Data curation, Formal analysis, Methodology, Writing – original draft; Zhiwei Lin: Resources, Software, Visualization; Ru Yingtao: Data curation, Writing – original draft; Tao Huang: Supervision, Writing – review and editing

FUNDING INFORMATION

This project is supported by “the Fundamental Research Funds for the Central Universities (B230201048)”.

CONFLICT OF INTEREST STATEMENT

The authors declare no conflicts of interest.

DATA AVAILABILITY STATEMENT

The data that support the findings of this study are available on request from the corresponding author. The data are not publicly available due to privacy or ethical restrictions.

ORCID

Yingjun Wu  <https://orcid.org/0000-0002-5533-111X>

REFERENCES

- Panteli, M., Trakas, D.N., Mancarella, P., Hatziaargyriou, N.D.: Boosting the power grid resilience to extreme weather events using defensive islanding. *IEEE Trans. Smart Grid.* 7(6), 2913–2922 (2016)
- Liu, X., Shahidehpour, M., Li, Z., Liu, X., Cao, Y., Bie, Z.: Microgrids for enhancing the power grid resilience in extreme conditions. *IEEE Trans. Smart Grid.* 8(2), 589–597 (2017)
- Nazemi, M., Moeni-Aghaie, M., Fotuhi-Firuzabad, M., Dehghanian, P.: Energy storage planning for enhanced resilience of power distribution networks against earthquakes. *IEEE Trans. Sustain. Energy.* 11(2), 795–806 (2020)
- Yan, M., He, Y., Shahidehpour, M., Ai, X., Li, Z., Wen, J.: Coordinated regional-district operation of integrated energy systems for resilience enhancement in natural disasters. *IEEE Trans. Smart Grid.* 10(5), 4881–4892 (2019)
- Bompard, E., Huang, T., Wu, Y., Cremenescu, M.: Classification and trend analysis of threats origins to the security of power systems. *Int. J. Electr. Power.* 50(1), 50–64 (2013)
- Wang, Y., Chen, C., Wang, J., Baldick, R.: Research on resilience of power systems under natural disasters—A review. *IEEE Trans. Power Syst.* 31(2), 1604–1613 (2016)
- Watson, E.B., Etemadi, A.H.: Modeling electrical grid resilience under hurricane wind conditions with increased solar and wind power generation. *IEEE Trans. Power Syst.* 35(2), 929–937 (2020)
- Li, G., Zhang, P., Luh, P.B., Li, W., Bie, Z., Serna, C., Zhao, Z.: Risk analysis for distribution systems in the Northeast U.S. under wind storms. *IEEE Trans. Power Syst.* 29(2), 889–898 (2014)
- Liu, X., Hou, K., Jia, H., Zhao, J., Mili, L., Jin, X., Wang, D.: A planning-oriented resilience assessment framework for transmission systems under typhoon disasters. *IEEE Trans. Smart Grid.* 11(6), 5431–5441 (2020)
- Ding, T., Qu, M., Wang, Z., Chen, B., Chen, C., Shahidehpour, M.: Power system resilience enhancement in typhoons using a three-stage day-ahead unit commitment. *IEEE Trans. Smart Grid.* 12(3), 2153–2164 (2021)
- Huang, G., Wang, J., Chen, C., Qi, J., Guo, C.: Integration of preventive and emergency responses for power grid resilience enhancement. *IEEE Trans. Power Syst.* 32(6), 4451–4463 (2017)
- Liu, J., Qin, C., Yu, Y.: Enhancing distribution system resilience with proactive islanding and RCS-based fast fault isolation and service restoration. *IEEE Trans. Smart Grid.* 11(3), 2381–2395 (2020)
- Jamborsalamati, P., Hossain, M.J., Taghizadeh, S., Konstantinou, G., Manbachi, M., Dehghanian, P.: Enhancing power grid resilience through an IEC61850-based EV-assisted load restoration. *IEEE Trans. Ind. Inf.* 16(3), 1799–1810 (2020)
- Chen, W., Shi, Y., Chen, Y., Li, Y., Guo, C., Yang, C., Shen, Y.: Robust islanded restoration coordinating multiple distributed resources to enhance resilience of active distribution system. In: *IEEE Power and Energy Society General Meeting (PESGM)*. Atlanta, GA, pp. 1–5 (2019)
- Gholami, A., Shekari, T., Aminifar, F., Shahidehpour, M.: Microgrid scheduling with uncertainty: The quest for resilience. *IEEE Trans. Smart Grid.* 7(6), 2849–2858 (2016)
- Ding, T., Wang, Z., Jia, W., Chen, B., Chen, C., Shahidehpour, M.: Multi-period distribution system restoration with routing repair crews, mobile electric vehicles, and soft-open-point networked microgrids. *IEEE Trans. Smart Grid.* 11, 4795–4808 (2020)
- Kianmehr, E., Nikkhah, S., Vahidinasab, V., Giaouris, D., Taylor, P.C.: A resilience-based architecture for joint distributed energy resources allocation and hourly network reconfiguration. *IEEE Trans. Ind. Inf.* 15(10), 5444–5455 (2019)
- Gao, H., Chen, Y., Mei, S., Huang, S., Xu, Y.: Resilience-oriented pre-hurricane resource allocation in distribution systems considering electric buses. *Proc. IEEE.* 105(7), 1214–1233 (2017)
- Shin, H., Baldick, R.: Plug-in electric vehicle to home (V2H) operation under a grid outage. *IEEE Trans. Smart Grid.* 8(4), 2032–2041 (2017)
- Yang, Z., Dehghanian, P., Nazemi, M.: Seismic-resilient electric power distribution systems: Harnessing the mobility of power sources. *IEEE Trans. Ind. Appl.* 56(3), 2304–2313 (2020)
- Wu, C., Mohsenian-Rad, H., Huang, J.: Vehicle-to-aggregator interaction game. *IEEE Trans. Smart Grid.* 3(1), 434–442 (2012)
- Ma, J., Deng, J., Song, L., Han, Z.: Incentive mechanism for demand side management in smart grid using auction. *IEEE Trans. Smart Grid.* 5(3), 1379–1388 (2014)
- Wu, Y., Lin, Z., Liu, C., Chen, Y., Uddin, N.: A demand response trade model considering cost and benefit allocation game and hydrogen to electricity conversion. *IEEE Trans. Ind. Appl.* 58(2), 2909–2920 (2022)
- Kim, D., Kim, J.: Design of emergency demand response program using analytic hierarchy process. *IEEE Trans. Smart Grid.* 3(2), 635–644 (2012)
- Guo, Y., Li, H., Pan, M.: Colocation data center demand response using Nash bargaining theory. *IEEE Trans. Smart Grid.* 9(5), 4017–4026 (2018)
- Dong, Y., Xie, X., Wang, K., Zhou, B., Jiang, Q.: An emergency-demand-response based under speed load shedding scheme to improve short-term voltage stability. *IEEE Trans. Power Syst.* 32(5), 3726–3735 (2017)
- Abedi, S.M., Haghifam, M.R.: CDF-based reliability insurance contracts considering free-riding. *Int. J. Electr. Power Energy Syst.* 53, 949–955 (2013)
- Batts, M.E., Cordes, M.R., Russell, L.R., Shaver, J.R., Simiu, E.: Hurricane wind speeds in the United States. *J. Struct. Div.* 106(124), 2001–2016 (1980)
- Panteli, M., Pickering, C., Wilkinson, S., Dawson, R., Mancarella, P.: Power system resilience to extreme weather: fragility modeling, probabilistic impact assessment, and adaptation measures. *IEEE Trans. Power Syst.* 32(5), 3747–3757 (2017)
- Mohammadi, R., Mashhadi, H.R., Shahidehpour, M.: Market-based customer reliability provision in distribution systems based on game theory: A bi-level optimization approach. *IEEE Trans. Smart Grid.* 10(4), 3840–3848 (2019)
- Zhou, M., Wu, Z., Wang, J., Li, G.: Forming dispatchable region of electric vehicle aggregation in microgrid bidding. *IEEE Trans. Ind. Inf.* 17(7), 4755–4765 (2021)
- Tadj, L., Touzene, A.: A QBD approach to evolutionary game theory. *Appl. Math. Model.* 27(11), 913–927 (2003)
- Baran, M.E., Wu, F.F.: Optimal capacitor placement on radial distribution systems. *IEEE Trans. Power Delivery.* 4(1), 725–734 (1989)
- Wang, C., Ju, P., Lei, S., Wang, Z., Wu, F., Hou, Y.: Markov decision process-based resilience enhancement for distribution systems: An approximate dynamic programming approach. *IEEE Trans. Smart Grid.* 11(3), 2498–2510 (2020)

35. Poudel, S., Dubey, A.: Critical load restoration using distributed energy resources for resilient power distribution system. *IEEE Trans. Power Syst.* 34(1), 52–63 (2019)
36. Momen, H., Abessi, A., Jadid, S.: Using EVs as distributed energy resources for critical load restoration in resilient power distribution systems. *IET Gener. Transm. Dis.* 14(18), 3750–3761 (2020)

How to cite this article: Wu, Y., Liu, C., Lin, Z., Ru, Y., Huang, T.: Enhancing resilience by reducing critical load loss via an emergent trading framework considering possible resources isolation under typhoon. *IET Gener. Transm. Distrib.* 17, 3184–3197 (2023).
<https://doi.org/10.1049/gtd2.12888>