

The flexibility of virtual energy storage based on the thermal inertia of buildings in renewable energy communities: A techno-economic analysis and comparison with the

Original

The flexibility of virtual energy storage based on the thermal inertia of buildings in renewable energy communities: A techno-economic analysis and comparison with the electric battery solution / Fambri, G., Marocco, P., Badami, M., Tsagkrasoulis, D.. - In: JOURNAL OF ENERGY STORAGE. - ISSN 2352-152X. - 73:(2023). [10.1016/j.est.2023.109083]

Availability:

This version is available at: 11583/2983365 since: 2023-10-26T10:25:01Z

Publisher:

Elsevier

Published

DOI:10.1016/j.est.2023.109083

Terms of use:

This article is made available under terms and conditions as specified in the corresponding bibliographic description in the repository

Publisher copyright

(Article begins on next page)



Research Papers

The flexibility of virtual energy storage based on the thermal inertia of buildings in renewable energy communities: A techno-economic analysis and comparison with the electric battery solution

Gabriele Fambri^{a,*}, Paolo Marocco^a, Marco Badami^a, Dimosthenis Tsagkrasoulis^b

^a Dipartimento Energia, Politecnico di Torino, Corso Duca degli Abruzzi 24, 10129 Torino, Italy

^b Hypertech Energy Labs, Hypertech SA, 15232 Chalandri, Greece



ARTICLE INFO

Keywords:

Sector coupling
Heat pumps
Renewable energy community
Energy storage
Flexibility
Building thermal inertia

ABSTRACT

The Renewable Energy Community (REC) concept has been introduced into the European decarbonization guidelines to promote the utilization of Renewable Energy Sources (RES) and to incentivize their self-consumption at the local level. This paper analyzes the flexible use of Heat Pumps (HP) for building heating in an REC context. The Power-to-Heat (P2H) energy conversion process of HP allows the flexibility of the thermal sector to be exploited within the electricity sector: in this way, it is possible to store energy in the form of heat inside the building mass and then use the stored energy to reduce the building heating demand in the hours following the accumulation of energy. This energy storage solution has been defined as building-based Virtual Energy Storage (VES). The flexibility enabled by VES has been used to optimize the self-consumption of an REC. The flexible VES solution was evaluated, from a technical and economic point of view, through a sensitivity analysis on the variation of the RES penetration, and the results were compared with those based on a more traditional centralized electric battery (EB) storage system. The results demonstrated that the VES solution is less flexible than electric batteries. Nevertheless, both flexible solutions (VES and EB) can significantly increase the REC self-consumption: the self-consumed energy increased by between 6% and 44% thanks to the exploitation of the VES flexibility, while the EB flexibility enabled an increase in the self-consumed energy of 19% to 63% according to the scenario analyzed. However, due to the high investment cost of EB, the VES configuration resulted to be the best solution from an economic point of view.

1. Introduction

1.1. Background

The European Union aims to achieve carbon neutrality by mid-century [1], which requires the use of Renewable Energy Sources (RES). However, integrating RES into the distribution system poses important challenges. The introduction of RES changes the centralized electricity system paradigm, and the current protection system and control schemes are not designed to operate under these conditions [2]. To integrate distributed renewable resources more efficiently and

increase self-consumption, flexibility needs to be introduced at the distribution level [3].

The European Union, with the Renewable Energy Directive n.2001/2018 (RED II) [4] and the Internal Electricity Market Directive n.944/2019 (IEM) [5], introduced the entity of the Renewable Energy Community (REC) to incentivize the consumption of different types of distributed renewable energy. REC are groups of RES self-consumers that act collectively to produce clean electricity, share it, and consume it directly on site. An REC must be equipped with one or more renewable production plants, the most common types being photovoltaic, wind and biomass plants. Members must use the existing electricity grid to

Acronyms: AT, Annual Throughput; BC, Base Case; BOS, Balance of System; CO₂, Carbon dioxide; COP, Coefficient Of Performance; CP2H, Centralized Power-to-Heat; DTW, Dynamic Time Warping; EB, Electric Battery; HP, Heat Pump; ICT, Information and Communications Technology; KPI, Key Performance Indicator; LP2H, Localized Power-to-Heat; LT, Lifetime Throughput; MES, Multi-Energy System; MPC, Model Predictive Control; NPV, Net Present Value; NZEB, Nearly Zero-Energy Building; O&M, Operation and Maintenance; P2H, Power-to-Heat; PCM, Phase Change Material; PV, Photovoltaic; REC, Renewable Energy Community; RES, Renewable Energy Sources; RPF, Reverse Power Flow; SoC, State of Charge; SMEs, Small and Medium-sized Enterprises; VES, Virtual Energy Storage.

* Corresponding author.

E-mail address: gabriele.fambri@polito.it (G. Fambri).

<https://doi.org/10.1016/j.est.2023.109083>

Received 26 July 2022; Received in revised form 19 July 2023; Accepted 22 September 2023

Available online 13 October 2023

2352-152X/© 2023 The Authors. Published by Elsevier Ltd. This is an open access article under the CC BY license (<http://creativecommons.org/licenses/by/4.0/>).

exchange the self-produced electricity [6]. The installation and use of renewable sources is promoted through incentives for the production of energy and for its self-consumption. The goal of such communities is to promote sustainable and resilient territories by favoring the penetration of RES at the local level.

Flexible resources that are capable of following the fluctuating production of RES could be exploited to optimize the self-consumption of renewables [7,8]. One of the most immediate solutions is that of using the flexibility offered by electric batteries [9]. However, as concluded in [10], if only the electricity sector is analyzed, other solutions that may be more efficient might be excluded. It is possible that alternative solutions could emerge if the problem is faced through a holistic approach that assesses the energy system as a whole: i.e., considering the possible synergies with other energy sectors [11,12]. This type of solution is known as the Multi-Energy System (MES) approach [13]. In general, non-electric energy sectors show an intrinsic flexibility, as they do not require a constant balance between generation and consumption [14]. Energy conversion technologies can be used as a connection between different energy sectors [15]. In this way, it is possible to exploit the intrinsic flexibility of other energy sectors within the electricity sector. Various flexible solutions, resulting from the integration of different energy sectors, have been analyzed in the literature, such as electric mobility [16,17], the gas sector [14,18], district heating/cooling [19,20], hydrogen-based applications [21,22] and demand response domestic devices [23,24].

The current European decarbonization policies are encouraging countries to electrify their building heating sectors [25]. This opens the way to new sources of flexibility which, if exploited, can be used to support the balancing of the electricity grid. Indeed, if buildings are equipped with stand-alone electric heating devices (i.e., Localized Power-to-Heat, LP2H) such as electric Heat Pumps (HP), the inherent flexibility of the building heating sector can be released and used in the electricity sector [26]. The heating systems of buildings do not normally work at their nominal capacity: they are designed to provide heat to a building under the most extreme conditions, and when these conditions do not occur, they work at a lower load. For this reason, the design of LP2H systems inherently offers the possibility of using the available capacity in a flexible manner. At the same time, European directives are promoting the efficiency of buildings in view of the Nearly Zero-Energy Building (NZEB) target [27]. According to the NZEB principle, new buildings should be characterized by a high thermal insulation, which makes it possible to retain the heat of the building and to have low thermal energy losses: features that enhance the flexibility of LP2H devices [28].

The electricity consumption of LP2H devices can be modulated with a certain degree of flexibility since, due to the thermal inertia of the building thermal mass, the thermal response of the buildings is not immediate. Moreover, the indoor temperature setpoint of buildings could be flexibly regulated over a pre-determined range (without violating the internal thermal comfort), so as to further regulate the electricity consumption of the LP2H devices. As described in Section 3.1, from the electricity sector point of view, this flexible load could be equated with pure electrical storage according to a Virtual Energy Storage (VES) concept [26,29–32]. Specifically, a building-based VES exploits the heat storage capacity of a building (which depends on its thermal inertia) to provide flexibility for the electricity sector. In this way, the load of the LP2H devices could be flexibly controlled to follow the RES production and, in case of REC context, be exploited to improve the REC self-consumption.

1.2. Literature review

The energy flexibility of buildings, via LP2H devices, has gained momentum in recent years. In [33], the authors developed a VES model based on a building space equivalent thermal model and used it to calculate the optimal schedule for VES operation. The storage capacity

and efficiency of VES were evaluated considering the parameters of buildings and the accumulation time in [28]. A building-based VES model was presented in [30]: the VES was integrated in an economic dispatching model of a hybrid microgrid in order to effectively reduce daily operating costs. In [34], the authors analyzed the thermal storage capacity that is intrinsically present in a building mass by considering an apartment-block building and a single family house, and they concluded that low-energy buildings are particularly suitable for providing flexibility because of their large heat capacity. In [31], quantitative indicators were proposed to investigate the energy flexibility potential of building-based VES. An increase in the total operational profit was observed in [32] when loads with VES capability are integrated in the smart microgrid model. The authors of [35] investigated the performance of an LP2H device and PV panels under different electricity pricing strategies. A smart controller activated the flexible LP2H as a function of the day ahead electricity price so as to reduce overloading of the electricity network and, at the same time, to reduce the LP2H operation cost. In [36], the authors investigated how the flexibility enabled by LP2H, used for air conditioning in Singapore, could be exploited to provide ancillary services for the electricity sector. In [37], the flexibility of these systems was quantified using specific flexibility parameters defined by the thermophysical properties of the building and the characteristics of the LP2H systems. In [38], the authors studied, through a sensitivity analysis, how the building envelope, the weather conditions and the users' behavior affect VES flexibility. For the sake of completeness, it should also be mentioned that numerous articles (e.g., in [39–41]) have dealt with the flexibility of LP2H coupled with dedicated thermal storage systems, which allow the flexibility of LP2H systems to be exploited, with less effect on the internal thermal comfort. Nevertheless, the strength of the VES approach is that, as also concluded in [34], no new components need to be installed to activate this flexibility, except for the monitoring and control system devices: in fact, the VES flexibility is enabled only by the heating system and the thermal mass of the building. For this reason, only the use of the thermal mass of buildings for heat storage is considered in our work. The use of additional thermal storage systems is beyond the scope of this analysis.

1.3. Scientific contribution

The energy system analyzed in this work is a Multi-Energy System (MES) that encompasses the electricity sector and the heat demand sector of buildings connected through LP2H technologies. This allows the building thermal mass to be used as VES units, thereby enabling the internal flexibility of the building's heating sector.

The flexibility enabled by VES has been compared with the that offered by a centralized Electric Battery (EB) in the context of renewable energy communities. The flexible use of both technologies makes it possible to modulate the consumption of electricity at the local level and improve the match between the generation and consumption of energy. This in turn leads to an increase in the self-consumption of renewable energy produced by the energy community and, consequently, an increase in earnings for dedicated incentives. The energy flows of the energy community were assessed on an annual basis. VES and EB solutions were compared, from an energy point of view, by calculating the self-sufficiency and self-consumption of the REC, and from an economic point of view, by calculating the cash flows of the energy community on an annual basis and the Net Present Value (NPV).

The remainder of this paper is structured as follows: the analyzed energy system scenario is described in Section 2; Section 3 reports and discusses the simulation results, whereas Section 4 discusses the main conclusions.

2. Method

2.1. Multi-energy system configurations

The REC has been analyzed from an MES point of view that encompasses the electricity sector and the heating sector. Three different REC configurations have been investigated:

- The Base case (BC), where the electricity and heating sectors are connected through LP2H distributed systems. However, the LP2H systems are not controlled to offer flexibility. Therefore, in this case, the LP2H systems constitute a non-flexible load. See Fig. 1a.
- The VES case, which, from the point of view of the technologies installed within the REC, is the same as the Base case. However, in this case, the LP2H systems are controlled to enable VES flexibility, which is used to optimize the energy flows of the REC. See Fig. 1b.
- The EB case, where a centralized electrical storage system is connected to the photovoltaic plant. An electric battery allows the energy produced by the PV plant to be absorbed and released flexibly according to the needs of the REC. In this case, the VES flexibility is not exploited and the electricity consumption of the LP2H systems constitutes a non-flexible load, as in the Base case. See Fig. 1c.

Compared to the Base case and the VES case, the EB case requires an added investment cost, due to the installation and maintenance of the electric battery.

The three cases were simulated separately for a whole year with a temporal discretization of 15 minutes.

2.2. Case study

2.2.1. Renewable energy community

As described in Section 2.3, the VES model was created on the basis of real data from buildings located in a village in the Western Alps, near the border between Italy and France (about 600 m above sea level). The climatic and solar radiation data used for the simulation (to estimate the heat demand of the buildings and photovoltaic production) were also taken from the same site as the pilot plant.

It was assumed that the REC, located in Italy, consists of 50 single-family terraced villas (this number of users was chosen as it is in line with a possible size of an energy community in the Italian context). The buildings were hypothesized to all be the same and each to have an area of 100 m². It was assumed that the dwellings are all new generation, energy class A buildings, according to the European Directive 2010/31/EU classification [42] (i.e., with an annual consumption of thermal energy between 15 and 30 kWh/m² per year). All the REC users were considered to be equipped with floor heating systems combined with ground source Heat Pump (HP), i.e., the LP2H systems. Each HP has a nominal electric power of 3 kW. In this case study LP2H systems are considered to only be used for heating. The users' heat demand and the

resulting electricity consumption of the LP2H devices were calculated as a function of the climatic profiles (see Fig. 2) by means of the VES model described in Section 2.3: the model (which includes a building thermal model) simulates the thermodynamic behavior of buildings of an REC of 50 residential users. The mathematical model calculates the aggregate demand of all buildings and the resulting electrical load of the LP2H devices (see Fig. 3).

The electricity consumption of the users, excluding the electricity consumption of the LP2H devices, was estimated from a characteristic profile of the electricity consumption of residential users (this electric load represents the electrical consumption of household appliances, lighting, etc. See Fig. 4). From here on we will refer to this electrical consumption with the term "passive load", since, unlike the electrical consumption of the LP2H devices, it is a non-flexible electrical load.

The renewable energy community was hypothesized to have a 40 kW photovoltaic plant. The annual production profile of the plant is shown in Fig. 5. In order to consider different levels of PV penetration, the results of a sensitivity analysis, performed by varying the installed photovoltaic power, are presented in Sections 3.3 and 3.4. A maximum capacity of the PV plant of 60 kW was taken into account. A larger PV plant was not considered as the installation of a plant of this size would unlikely be economically viable for the REC and was therefore considered as an unrealistic scenario. In the case with the electric battery, it was assumed that the REC is equipped with a centralized lithium-ion electrical storage system, with a capacity of 145 kWh, connected directly to the PV plant. The EB capacity was chosen to conduct a consistent comparison between the flexibility of the VES and EB solutions: the EB capacity was chosen to be close to the storage capacity of the VES portfolio (see Section 3.2); however, for the sake of completeness, a sensitivity analysis on the variation of the EB capacity has been conducted and the results are presented Section 3.4.

The parameters of this scenario and the range of the sensitivity analyzes are summarized in Table 1.

2.2.2. Costs and incentives

According to the Italian Law 8/2020 [44,45], any electricity fed into the grid by a renewable energy community is remunerated at 50 €/MWh. Italian legislation introduced incentives for a period of 20 years to encourage the self-consumption of energy. In particular, an REC receives 110 € for each self-consumed MWh as an incentive for self-consumption, plus an additional 8 € for each self-consumed MWh as an incentive for unused charges for the transport and distribution of electricity. The expenditure for the energy taken from the network is calculated considering a purchase price of 210–230 €/MWh (depending on the time of day) [46]. The REC energy flows (the electricity consumption, the electricity fed into the grid and the self-consumed electricity) are evaluated on an hourly basis [44,45].

All the possible electricity flows of the analyzed scenario are summarized in Fig. 6. The PV plant is connected directly to the grid. In the periods in which the REC consumes the energy produced by the PV plant

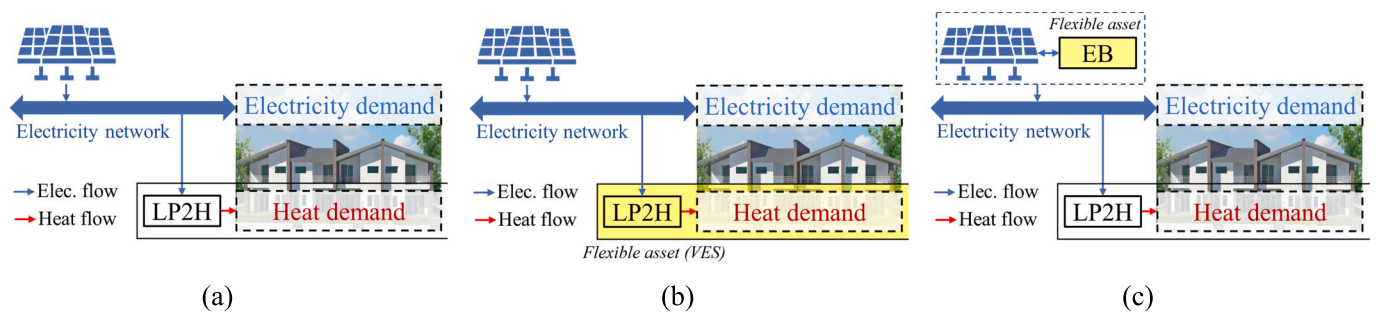

Fig. 1. Layout of the multi-energy system: Base case (a), VES case (b) and EB case (c). The asset that can offer flexibility for the REC has been highlighted in yellow in the figure: in the Base case, there is no flexibility asset; in the VES case, the LP2H units offer flexibility for the REC; and in the EB case, the flexibility is enabled by the electricity storage plant.

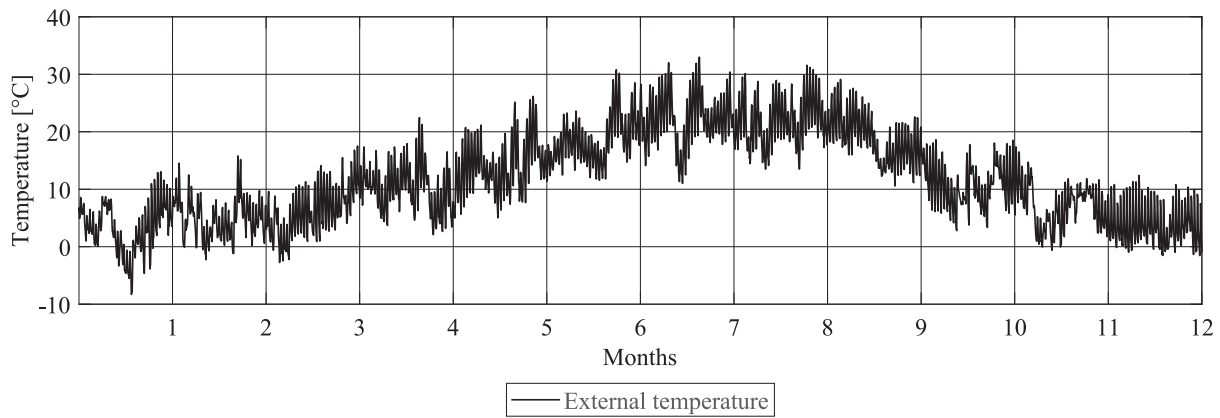

Fig. 2. Annual profile of the external temperature [43].

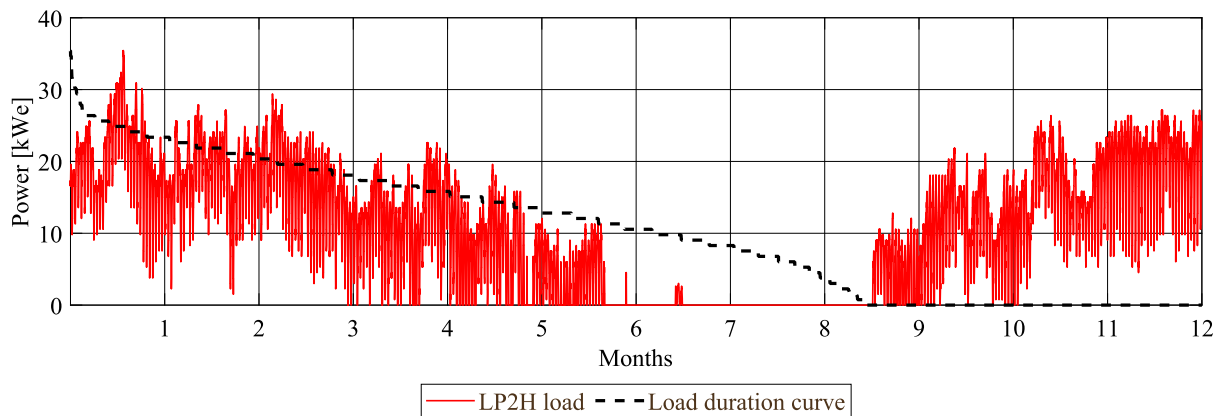

Fig. 3. Annual profile of the LP2H electricity load and its load duration curve.

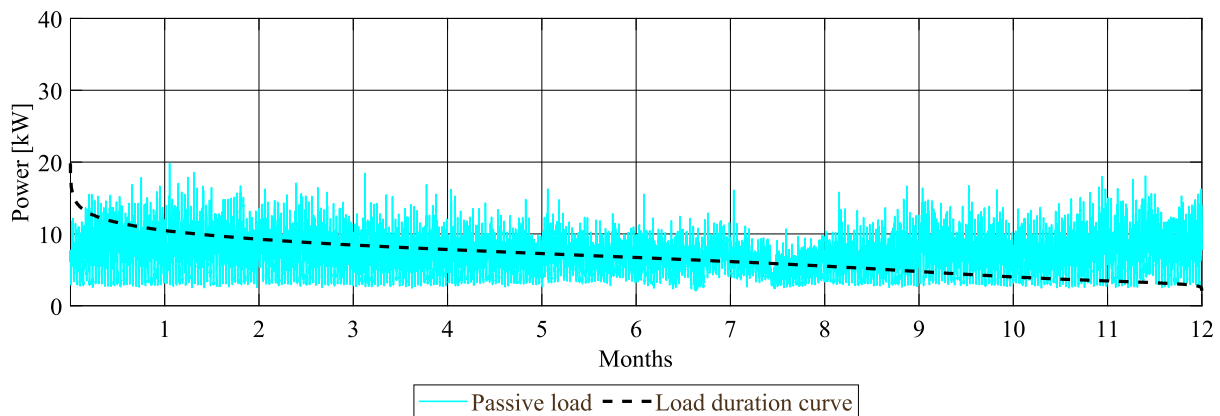

Fig. 4. Annual profile of the passive electricity load and its load duration curve (this profile does not include the electricity consumption of the LP2H units).

(green arrow), the community sells energy to the grid at a price of 50 €/MWh, buys energy from the grid at a price of 210–230 €/MWh and receives incentives of 110 € plus 8 € per MWh, since that energy is self-consumed. If the PV electricity injected into the grid is not consumed by the REC users (red arrow), the electricity production is remunerated at 50 €/MWh. In the EB case, the electrical storage is directly connected to the PV system. When the centralized electrical storage absorbs the PV energy, the energy flow does not pass from the grid (purple arrow) and there are therefore neither costs nor revenues. When the battery releases energy to cover the consumption of the REC (yellow arrow), the energy

is sold to the grid and purchased by the REC, with the corresponding incentives for electricity production and self-consumption. The main REC costs and incentives are summarized in Table 2.

2.2.3. Flexible asset cost assumption

As reported in different papers [34,35,38,47], one of the main advantages of exploiting the flexibility provided by the building-based VES is that this flexible solution is enabled by the thermal mass of the buildings and the heating system device, both of which are already available for each building of the selected case study, therefore with no

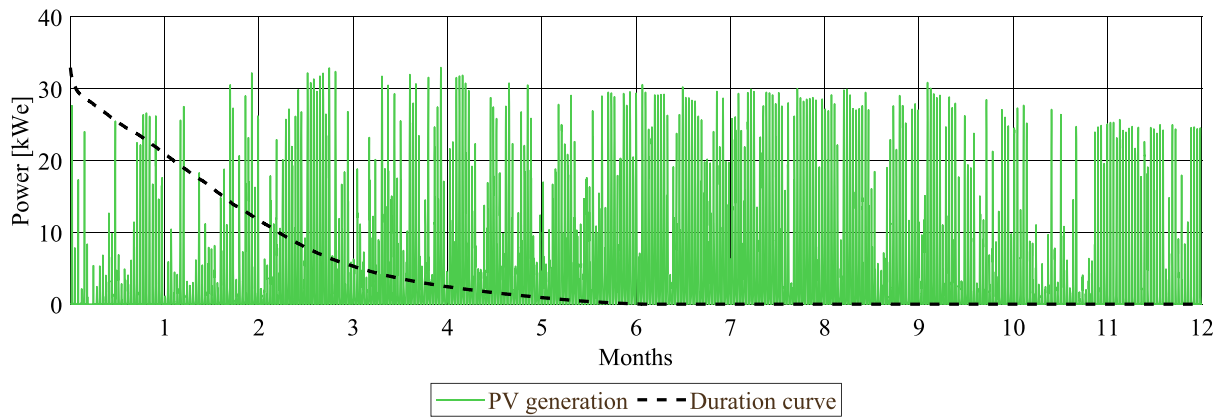

Fig. 5. Annual profile of PV production and its duration curve (data are taken from [43]).

Table 1
Parameters of the considered scenario.

Parameter	Unit	Reference Value	Sensitivity analysis
Number of residential users	-	50	-
PV installed power	kW	40	20–60
EB capacity	kWh	145	30–145

need of any additional cost. To control the LP2H devices in a flexible manner, it is necessary to have a suitable control of the heating system, which needs to be equipped with smart meters and dedicated software to manage the heating of a building. However, as also concluded in [34,47], in new residential buildings (such as those analyzed in this case study), the heating system is connected to a building management system. It would be sufficient to reprogram the management software to flexibly control the LP2H systems, without any need to invest in new components.

In [48], the authors collected several reports on the evolution of the cost of lithium-ion stationary batteries ([49–53]). They concluded that the investment cost for lithium-ion batteries is still very uncertain. Considering the studies analyzed in that report, the total investment cost of a lithium-ion battery storage system (including the battery pack, the balance of system, power conversion system, the energy management system and the construction) was estimated to cover a wide range, between 100 and 850 €/kWh, while, by 2030, it will be between 80 and 750 €/kWh. For this study, the investment cost is assumed to be 450 €/kWh, while the replacement cost is half of the investment cost (i.e., 225 €/kWh) [54]. The EB replacement cost takes place when the battery reaches the end of its lifetime, which was computed according to how it

operates over the year (See Appendix). According to [55,56], the annual O&M cost of the battery is assumed to be equal to 1% of total investment cost. The EB cost assumptions are summarized in Table 3.

2.3. The virtual energy storage model

2.3.1. Forecast of the energy demand for heating of the buildings

The building module utilizes a second-order thermal resistor-capacitor (3R2C) equivalent model (see Fig. 7). It models the thermal resistance between all the sets of indoor, envelope and external

Table 2
Costs and incentives for the renewable energy community.

Parameter	Unit	Value
Electricity purchase price (8:00–18:00)	€/MWh	230
Electricity purchase price (18:00–8:00)	€/MWh	210
Electricity sold to the grid	€/MWh	50
Incentives for self-consumption	€/MWh	110
Compensation for unused charges for electricity transport and distribution	€/MWh	8
Incentive lifetime	years	20

Table 3
The main economic parameters of the electric battery plant.

Parameter	Unit	Value
Inv. cost for EB	€/kWh	450
EB O&M	% Inv. cost /year	1
EB replacement cost	% Inv. cost	50

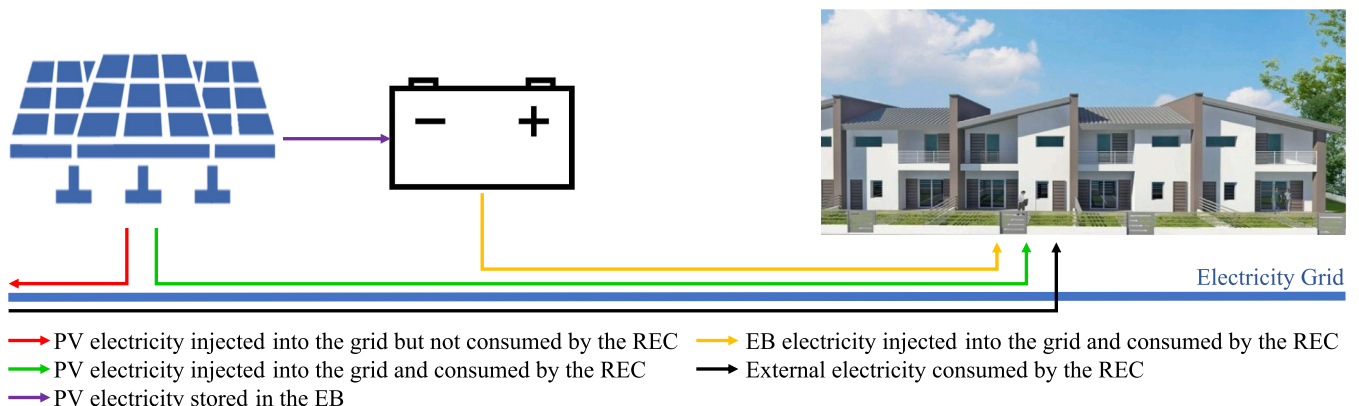

Fig. 6. REC electricity flows.

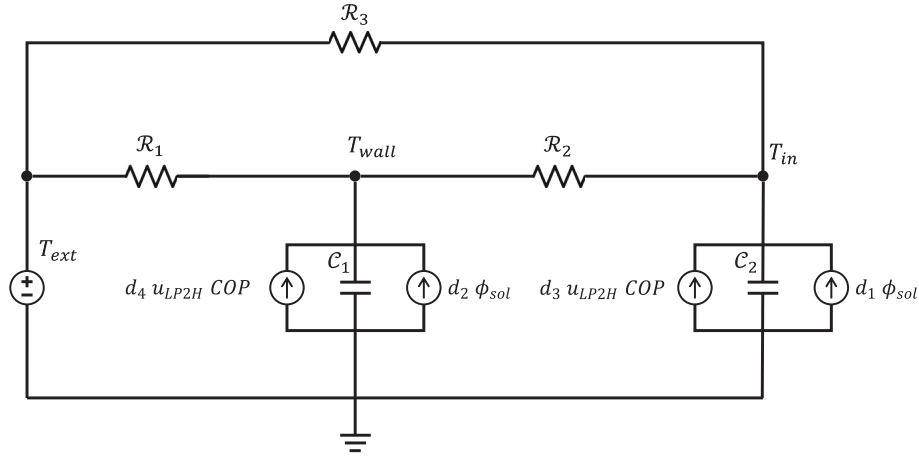

Fig. 7. Building circuit-equivalent thermal resistor-capacitor (3R2C) model.

temperatures, as well as the thermal capacitance of the indoor area and the building's envelope. The resulting state space model captures the dynamic thermal behavior of a building. LP2H and solar irradiance are considered as only heat sources.

The main symbols used in the 3R2C model (Fig. 7) are reported below:

- T_{in} [K] is the building's indoor temperature;
- T_{wall} [K] is the temperature of the building's walls;
- T_{ext} [K] is the external temperature;
- ϕ_{sol} [kW] represents the solar gains;
- u_{LP2H} [kW] is the electricity consumption of the LP2H unit;
- COP [-] is the coefficient of performance of the LP2H unit;
- \mathcal{C}_1 [kJ/K] is the thermal capacitance of the walls' thermal node;
- \mathcal{C}_2 [kJ/K] is the thermal capacitance of the indoor air's thermal node;
- \mathcal{R}_1 , [K/kW] is the thermal resistance between the external air node and the walls' thermal node;
- \mathcal{R}_2 [K/kW] is the thermal resistance between the walls' thermal node and the indoor air's thermal node;
- \mathcal{R}_3 , [K/kW] is the thermal resistance between the external air node and indoor air's thermal node;
- d_1 [-] is the fraction of solar heat that heats the indoor air's thermal node;
- d_2 [-] is the fraction of solar heat that heats the walls' thermal node ($d_1 + d_2 = 1$);
- d_3 [-] is the fraction of LP2H heat that heats the indoor air's thermal node;
- d_4 [-] is the fraction of LP2H heat that heats the walls' thermal node ($d_3 + d_4 = 1$).

The analytical equation of the 3R2C circuit is:

$$\begin{bmatrix} T_{in}(k) \\ T_{wall}(k) \end{bmatrix} = e^{\mathbf{A}\tau} \begin{bmatrix} T_{in}(k-1) \\ T_{wall}(k-1) \end{bmatrix} + \mathbf{A}^{-1} [e^{\mathbf{A}\tau} - \mathbf{I}] \cdot \mathbf{B} \cdot \begin{bmatrix} T_{ext}(k-1) \\ \phi_{sol}(k-1) \\ u_{LP2H}(k-1) \end{bmatrix} \quad (1)$$

Where τ [h] is the duration of the time step and the matrixes \mathbf{A} , \mathbf{B} and \mathbf{I} are:

$$\mathbf{A} = \begin{bmatrix} \frac{1}{\mathcal{R}_2 \cdot \mathcal{C}_2} - \frac{1}{\mathcal{R}_3 \cdot \mathcal{C}_2} & \frac{1}{\mathcal{R}_2 \cdot \mathcal{C}_2} \\ \frac{1}{\mathcal{R}_2 \cdot \mathcal{C}_1} & -\frac{1}{\mathcal{R}_1 \cdot \mathcal{C}_1} - \frac{1}{\mathcal{R}_2 \cdot \mathcal{C}_1} \end{bmatrix} \quad (2)$$

$$\mathbf{B} = \begin{bmatrix} \frac{1}{\mathcal{R}_2 \cdot \mathcal{C}_2} & \frac{d_1}{\mathcal{C}_2} & \frac{d_3 \cdot COP}{\mathcal{C}_2} \\ \frac{1}{\mathcal{R}_1 \cdot \mathcal{C}_1} & \frac{d_2}{\mathcal{C}_1} & \frac{d_4 \cdot COP}{\mathcal{C}_1} \end{bmatrix} \quad (3)$$

$$\mathbf{I} = \begin{bmatrix} 1 & 0 \\ 0 & 1 \end{bmatrix} \quad (4)$$

Using a Maximum Likelihood identification process, the thermal parameters of the state space model ($\mathcal{R}_1, \mathcal{R}_2, \mathcal{R}_3, \mathcal{C}_1, \mathcal{C}_2, COP, d_1, d_2, d_3, d_4$) were estimated via monitored data regarding the environmental conditions, solar irradiance, indoor temperature and electricity consumption. To this end, real data were collected from residential dwellings in the pilot plant during a calibration phase.

The building's heating system consists of geothermal heat pumps (i. e., the LP2H device). These dwellings were equipped with a smart metering and environmental monitoring infrastructure, as well as a real-time communication system/gateway, which made data collection possible. Indoor temperature and LP2H electricity consumption data were available at a time granularity of one minute, while the external environmental conditions were recorded every hour and interpolated to extract values every quarter of an hour. The time step for the discretization of the thermal model (and subsequently of the optimization method) was 15 min. The identification of the parameters of the thermal model was made by fitting the state space models to data recorded over periods of approximately two months. The prediction capabilities of the trained models were then evaluated by simulating the indoor temperature and the LP2H electricity consumption for the subsequent day (96 intervals). Results were then compared with the readings shown on the sensors. In order to perform the comparison, the true and predicted timeseries were aligned using the Dynamic Time Warping (DTW). The error was then computed as the cumulative absolute difference between the values at all the time steps. The validation error in the experiments ranged between 15% and 20% for this 96-step (1 day) prediction evaluation process. When considering only a single step prediction (15 min), the errors were significantly lower, with an average error of approximately 5%.

2.3.2. Thermal comfort profile estimation and building thermal inertia flexibility

The flexibility of the LP2H system was determined by the range of acceptable temperature conditions of the building. The electrical consumption of the LP2H device could be changed, as long as the internal temperature remained within the limits of thermal comfort. The limits of the acceptable conditions were selected on the basis of the recorded indoor temperature and heating consumption data from the pilot

dwellings. Whenever an activation/deactivation of a heating device was observed (based on the consumption data), the internal temperature of the building was flagged at the time of the activation/deactivation as either a low or high temperature limit. The accumulation of these values for each dwelling provided an average low limit, an average high limit, and the associated standard deviations for both metrics. These values were used to estimate the thermal comfort limits. The mean limit value over the examined dwellings was considered as the setpoint of the baseline temperature. The lower/upper limits were reduced/increased for the alternative conditions by one standard deviation of the respective metric. Assuming a gaussian distribution of the values (as suggested by the recorded data), a temperature value that is one standard deviation below the low limit or one standard deviation above the high limit was considered to be acceptable approximately 70% of the time by the occupant. The building's baseline setpoint resulted to be 20.5 °C and the maximum acceptable temperature deviation was found to be equal to ± 2.5 °C.

The model incorporated a Model Predictive Control (MPC) process to forecast the baseline, the minimum and the maximum electricity that could be absorbed by the LP2H units. These calculations were performed at each time step k of the simulation. The following measures/values were used as input into the optimization process:

- the baseline internal temperature setpoint (T^0);
- the minimum and maximum acceptable internal temperature (T^{min} and T^{max} , respectively);
- the external temperature and irradiance (T_{ext} and ϕ_{sol} , respectively);
- the internal temperature at the previous time step (T_{in} at time step $k-1$).

Three distinct optimizations were performed: one using the baseline temperature setpoint, and two others using the minimum and maximum temperature limits. The combined output consists of three electricity power consumption values: the LP2H baseline value (u_{LP2H}^0 , to be noted that the annual profile of this parameters is shown in Fig. 3), the LP2H minimum load (u_{LP2H}^-) and the LP2H maximum consumption (u_{LP2H}^+).

$$u_{LP2H}^0(k) = f(T^0, T_{ext}(k), \phi_{sol}(k), T_{in}(k-1)) \quad (5)$$

$$u_{LP2H}^-(k) = f(T^{min}, T_{ext}(k), \phi_{sol}(k), T_{in}(k-1)) \quad (6)$$

$$u_{LP2H}^+(k) = f(T^{max}, T_{ext}(k), \phi_{sol}(k), T_{in}(k-1)) \quad (7)$$

The difference between the baseline and the maximum possible consumption is the VES upward flexibility available for the next step:

$$\pi_{VES}^+(k) = u_{LP2H}^+(k) - u_{LP2H}^0(k) \quad (8)$$

The difference between the baseline and the minimum possible consumption is the VES downward flexibility for the next step:

$$\pi_{VES}^-(k) = u_{LP2H}^0(k) - u_{LP2H}^-(k) \quad (9)$$

2.4. Electric battery storage model

The electric battery is modeled as an energy accumulator whose state of charge varies according to the energy it absorbs or releases.

$$SoC_{EB}(k) = SoC_{EB}(k-1) \cdot (1 - \lambda_{EB}) + \frac{u_{EB}(k) \cdot \tau \cdot \eta_{EB, ch}}{Cap_{EB}} - \frac{g_{EB}(k) \cdot \tau}{\eta_{EB, dc} \cdot Cap_{EB}} \quad (10)$$

where:

- $SoC_{EB}(k)$ [-] is the state of charge of the battery at time step k ;
- λ_{EB} [-] is the self-discharge rate of the battery (0.05%/month [57]);

- $u_{EB}(k)$ [kW] is the battery's electricity absorption at time step k ;
- $g_{EB}(k)$ [kW] is the battery's electricity generation at time step k ;
- τ [h] is the duration of the time step;
- $\eta_{EB, ch}$ [-] is the charging efficiency of the battery (equal to 0.95 [57]);
- Cap_{EB} [kWh] is the storage capacity of the battery;
- $\eta_{EB, dc}$ [-] is the discharging efficiency of the battery (equal to 0.95 [57]);

At each time step k of duration τ , the model calculates the upward ($\pi_{EB}^+(k)$) and downward ($\pi_{EB}^-(k)$) flexibility as follows:

$$\pi_{EB}^+(k) = \min \left\{ e_{EB}^{max}, \frac{Cap_{EB} \cdot (SoC_{EB}^{max} - SoC_{EB}(k-1))}{\eta_{EB, ch} \cdot \tau} \right\} \quad (11)$$

$$\pi_{EB}^-(k) = \min \left\{ e_{EB}^{max}, \frac{Cap_{EB} \cdot (SoC_{EB}(k-1) - SoC_{EB}^{min}) \cdot \eta_{EB, dc}}{\tau} \right\} \quad (12)$$

where:

- SoC_{EB}^{max} [-] is the maximum state of charge of the battery (equal to 1 [57]);
- SoC_{EB}^{min} [-] is the minimum state of charge of the battery (equal to 0.2 [57]);
- e_{EB}^{max} [kW] is the maximum input and output power of the battery;

The parameter C_rate [h^{-1}] defines the correlation between the maximum input and output power of the battery (e_{EB}^{max}) and the battery capacity (Cap_{EB}):

$$\frac{e_{EB}^{max}}{Cap_{EB}} = C_rate \quad (13)$$

The C_rate value is assumed to be equal to 0.25 h^{-1} .

When the generation and load of the REC are already balanced, the battery does not generate or absorb electrical energy. In this condition, the absorption and generation of the EB unit are therefore equal to zero:

$$u_{EB}(k) = g_{EB}(k) = 0 \quad (14)$$

2.5. The simulation control algorithms

2.5.1. Base case

Neither the VES nor the EB flexibility is used in the Base case. The load of the LP2H units (u_{LP2H}) is set equal to baseline setpoint u_{LP2H}^0 at each timestep k of the simulation (i.e., the electrical load that guarantees the maintenance of the internal setpoint temperature). The LP2H load only depends on the external temperature and the needs of the buildings, as described in Section 2.3.

$$u_{LP2H}(k) = u_{LP2H}^0(k) \quad (15)$$

2.5.2. VES case

The VES flexibility is exploited in the VES case. If the PV generation is lower than the total REC electricity demand (i.e., the passive load u_{pass} plus the LP2H base load u_{LP2H}^0), VES flexibility is not exploited and the LP2H setpoint is maintained equal to its baseload. When the PV generation exceeds the REC electricity demand, the flexibility of the VES is used to absorb the over-generation of PV. The flexibility of the VES is constrained by the thermal comfort limits (see Section 2.3), and if the over-generation of PV is too high it cannot be absorbed entirely by the VES: in this case, all the upward flexibility of the VES will be exploited. If, on the other hand, the over-generation is lower than the upward flexibility of the VES, the LP2H setpoint will deviate from its baseline

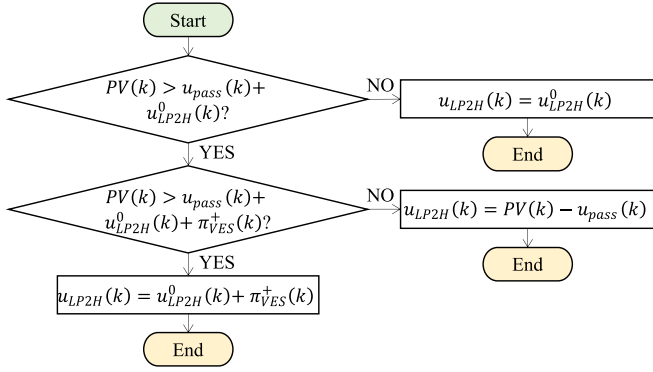

Fig. 8. The VES control algorithm.

value to completely absorb the over-generation of PV. The control algorithm for the definition of the electricity load of the LP2H for a generic timestep k is summarized in the flowchart of Fig. 8.

2.5.3. EB case

In the EB scenario, it is assumed that a centralized EB has been purchased. The electric battery works by balancing the PV production and the electricity demand of the REC. The EB can absorb the PV overproduction up to the limit defined by its upward flexibility (see Eq. 11). Similarly, the EB can supply energy to the REC up to the limit defined by its downward flexibility (see Eq. 12). The control algorithm implemented to define the load (u_{EB}) and generation (g_{EB}) of the electric battery at a generic timestep k is summarized in the flowchart of Fig. 9. In the EB case, the LP2H devices operate as non-flexible loads, in the same way as in the Base case (see Eq. 15).

2.6. Key performance indicators

2.6.1. Energy key performance indicators

The performance of the energy community was evaluated by calculating the self-consumed energy E_{SC} [MWh], the self-sufficiency (SS [%]) and self-consumption (SC [%]) parameters.

The self-consumed energy is the amount of energy produced and consumed within the REC and it is calculated as:

$$E_{SC} = \sum_{k=1}^K e_{SC}(k) \cdot \tau / 1000 \quad (16)$$

$$e_{SC}(k) = \begin{cases} u_{pass}(k) + u_{LP2H}(k), & \text{if } PV(k) > u_{pass}(k) + u_{LP2H}(k) \\ PV(k) + g_{EB}(k), & \text{if } PV(k) \leq u_{pass}(k) + u_{LP2H}(k) \end{cases} \quad (17)$$

where:

- K [-] is the number of time steps of the yearly simulation;
- $e_{SC}(k)$ [kW] is the self-consumed electricity at time step k ;

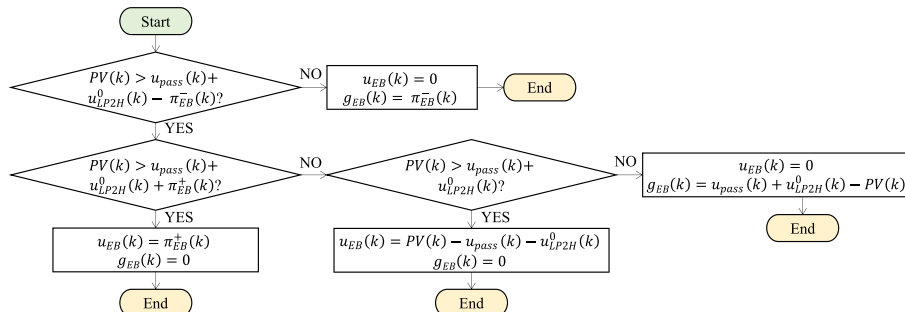

Fig. 9. The EB control algorithm.

- $u_{pass}(k)$ [kW] is the passive load at time step k ;
- $u_{LP2H}(k)$ [kW] is the electricity consumption of the LP2H units at time step k .

Self-sufficiency is defined as the ratio between the self-consumed energy and the community's electricity demand (E_{dem} [MWh]). While self-consumption is the ratio between the self-consumed energy (E_{SC} [MWh]) and the energy produced locally by the PV system (E_{PV} [MWh]):

$$SS = \frac{E_{SC}}{E_{dem}} \cdot 100 \quad (18)$$

$$SC = \frac{E_{SC}}{E_{PV}} \cdot 100 \quad (19)$$

2.6.2. Economic key performance indicators

To evaluate and compare the two flexible technologies from an economic point of view, we have compared the REC cash flows for the conditions without the installation of any flexibility asset (i.e., the BC), with the cash flows that occur when exploiting the VES and EB flexibility (i.e., the VES and EB cases, respectively). According to this approach, the annual incomes derived from enabling of the flexible assets (I_{VES} [€] and I_{EB} [€] for the VES and EB case, respectively) can be defined as follows:

$$I_{VES} = (R_{Inj,VES} - R_{Inj,BC}) + (R_{Inc,VES} - R_{Inc,BC}) - (E_{With,VES} - E_{With,BC}) \quad (20)$$

$$I_{EB} = (R_{Inj,EB} - R_{Inj,BC}) + (R_{Inc,EB} - R_{Inc,BC}) - (E_{With,EB} - E_{With,BC}) - O\&M_{EB} \quad (21)$$

where:

- $R_{Inj,BC}$, $R_{Inj,VES}$ and $R_{Inj,EB}$ [€] are the annual revenues for the electricity injected into the grid by the REC in the three different cases (BC, VES and EB);
- $R_{Inc,BC}$, $R_{Inc,VES}$ and $R_{Inc,EB}$ [€] are the annual REC revenues derived from all the incentives for the three cases;
- $E_{With,BC}$, $E_{With,VES}$ and $E_{With,EB}$ [€] are the total annual expenses of the REC for withdrawing electricity from the grid in the three cases;
- $O\&M_{EB}$ [€] is the annual operational and maintenance cost of the EB system.

On the basis of the incomes derived from the exploitation of the flexible technology, it is possible to calculate the Net Present Value (NPV [€]) of the two solutions (NPV_{VES} and NPV_{EB}). The calculation is performed considering a time horizon equal to the years for which the incentives are provided ($N = 20$ years) and assuming that the REC has the same energy demand each year and that the PV plant produces the same amount of energy.

$$NPV_{VES} = \sum_{j=0}^N \left(\frac{I_{VES,j}}{(1+r)^j} \right) \quad (22)$$

$$NPV_{EB} = \sum_{j=0}^N \left(\frac{I_{EB,j} - RC_{EB,j}}{(1+r)^j} \right) + \frac{SV_{EB,N}}{(1+r)^N} - INV_{EB,0} \quad (23)$$

where:

- $I_{VES,j}$ and $I_{EB,j}$ [€] are the annual incomes derived from the VES and EB flexibility solution, respectively, in the j -th year (Eq. 20 and Eq. 21 respectively);
- $RC_{EB,j}$ [€] is the EB replacement cost, which is applied when the battery reaches the end of its life. (See Appendix);
- $SV_{EB,N}$ [€] is the EB salvage value, which occurs at the end of time horizon N (See Appendix);
- $INV_{EB,0}$ [€] is the initial investment cost for the installation of the EB;
- r [-] is the discount rate, which was assumed to be equal to 5% [6].

3. Results

3.1. The virtual energy storage effect

The exploitation of the thermal inertia of the building allows the storage of thermal energy within the building envelope. However, this accumulation of thermal energy also has an impact on the electric side thanks to the LP2H systems which act as a bridge between the two energy sectors. From the perspective of the electrical sector, the effect of this accumulation of thermal energy can be equated to that of an electric battery that absorbs and releases electricity. However, since there is neither a real accumulation nor a release of electricity, this type of storage can be referred to as Virtual Energy Storage (VES) from the perspective of the electric sector. This section provides further explanation of this concept.

Fig. 10a shows the energy flows of the renewable energy community for the Base case. Although the simulation was carried out over the whole year, Fig. 10a refers to a characteristic day (20 April) to better show the effects of the control of the LP2H devices. The blue area is the passive electricity consumption of the REC; the green area is the electricity load of the LP2H systems. The black dotted curve is the renewable energy produced by the PV system of the REC. Part of the PV energy is consumed by the REC and the remainder (the over-generation, see the yellow area) is sold to the grid (but is not remunerated as self-consumption). The electricity consumption of the LP2H systems is controlled to keep the internal temperature of the buildings at 20.5 °C. Fig. 10a shows that the electricity consumption of the LP2H systems drops during the peak of renewable production until it reaches zero. This happens because solar radiation raises the building temperature and therefore the heat requirement of the buildings decreases.

The energy flows for the case of flexible use of LP2H systems (i.e., the VES case) are shown in Fig. 10b (the results refer to 20 April). The REC

electricity load coincides with that of the BC scenario up to 9:00 (point 1 in Fig. 10b). Before this point, the PV generation does not exceed the REC electricity consumption. Beyond this point, the controller modulates the LP2H consumption in order to absorb the renewable over-generation as much as possible. The over-generated PV is completely absorbed up to point 2: the over-generation is converted into thermal energy by the LP2H systems and stored inside the thermal mass of the buildings. When this happens, the internal temperature of the buildings increases. At point 2, the internal temperature of the buildings reaches 23 °C, which is the maximum thermal comfort limit. Once this limit is reached, the surplus energy can no longer be stored inside the buildings. From point 2 to point 3, the LP2H plant operates to maintain the internal temperature at the upper limit of 23 °C. When the PV over-generation ends (point 3), the LP2H systems are switched off: there is no need to heat the buildings as, thanks to the preheating of the previous hours, the internal temperature of the buildings is high enough to maintain thermal comfort. The internal temperature decreases due to the thermal losses of the buildings and, when it reaches 20.5 °C, the LP2H systems are switched on again to keep the internal temperature at this temperature level (point 4).

It should be noted that, thanks to the flexible use of these systems, it is possible to shift part of the electricity consumption of the renewable energy community in periods of renewable over-generation, thus allowing the PV self-consumption to be improved.

By comparing the energy flows of the Base case with those of the VES case, it can be seen that the effect of the flexible use of LP2H systems

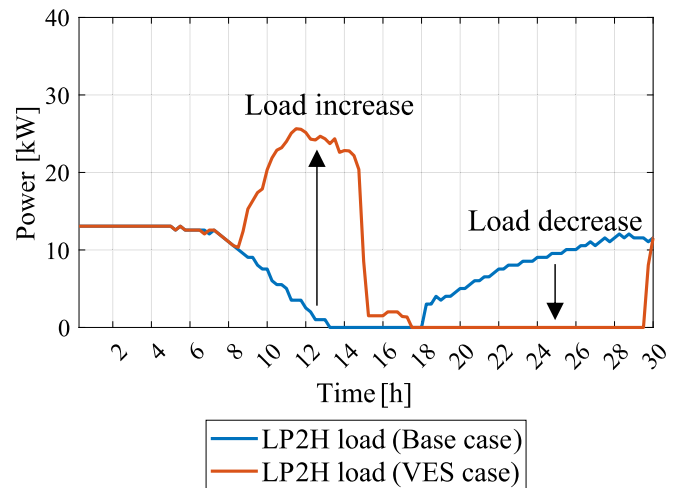

Fig. 11. LP2H electricity load in the Base case and VES case.

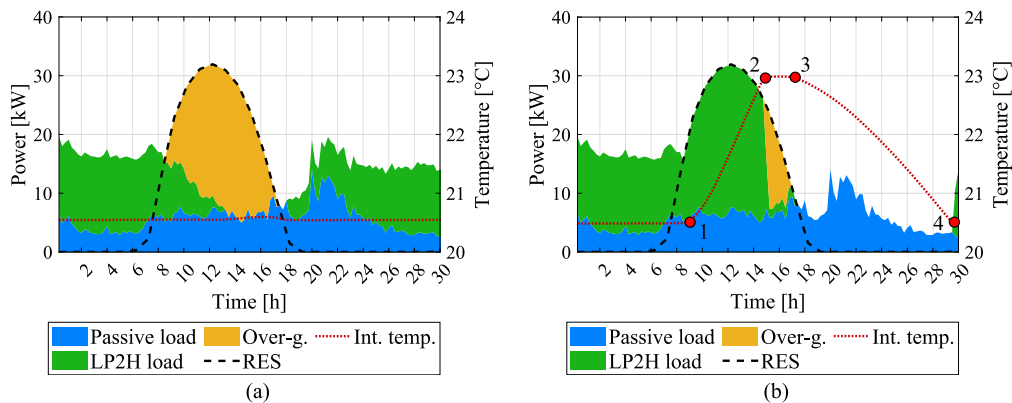

Fig. 10. Electricity balance of the renewable energy community and the indoor temperature of the buildings: base case (a) versus the VES case (b). Details pertaining to 20th April.

causes a shift in the electrical loads (see Fig. 11). This controlled increase and decrease of the electricity load can be equated with the effect of an electric accumulator. This interpretation of the energy flows is defined as a Virtual Energy Storage (VES) approach. When LP2H systems are required to consume more than in the Base case, it is interpreted as an accumulation of electrical energy inside the VES. It can be noted that the electrical consumption of the renewable energy community decreased between point 3 and point 4 in Fig. 10b, with respect to the Base case. In VES analogy, this is a release of electricity from the virtual batteries, whose accumulated energy is used to cover part of the electricity demand. In this case, the use of the term “virtual” is evident. In fact, there is no real release of electricity, although the overall effect (i.e., covering part of the electricity demand) is the same.

Fig. 12a highlights the electricity virtually accumulated and virtually released by VES. It can be seen that the released energy is less than the charged energy (see Fig. 12b). This difference is due to the fact that, when energy is accumulated in the VES, the thermal difference between the internal and external temperature of the buildings increases, thus increasing the heat losses. In the VES analogy, this difference corresponds to a non-unitary virtual storage efficiency.

The energy storage performance of VES depends on the structural parameters of the building and the technology used for heating. The better the thermal insulation of the building, the lower the heat losses and the more efficient the storage of thermal energy in the building envelope. For this reason, modern buildings, such as those examined in this study, allow for more efficient storage. In addition, it is more effective to store heat energy in the building envelope with radiant floor heating than with, for example, radiators or fan coils, which accumulate a lot of heat in the air through convection that can be easily dispersed. More details on the effects of building characteristics and heating technologies can be found in [28].

3.2. Virtual energy storage versus electric batteries

This section compares the effect of the VES solution on energy flows with those of EB. Fig. 13a shows the electricity flows of the renewable energy community for the case of the installation of an EB. It can be noted that the electricity consumption of the LP2H systems is the same as that of the Base case (see Fig. 10a). The flexibility of electric batteries is used when the renewable production exceeds the community's electricity demand: excess energy is accumulated inside the battery and released in the hours following the peak. The EB is not able to completely absorb the PV over-generation for the represented day. The EB can absorb energy until its SoC reaches its maximum level, and when this happens, the PV surplus is injected into the electricity grid. It can be seen that the electric battery releases the stored energy faster than the

VES. In fact, contrary to what happens in the VES case, the energy accumulated inside the batteries can be used to cover both the passive load (blue area) and the load of the LP2H units (see Fig. 13a), while the energy virtually accumulated inside the VES cannot be used to satisfy the passive load (see Fig. 12a). The two flexibility solutions are able to absorb roughly the same amount of energy before reaching saturation (see Fig. 12b and Fig. 13b). The EB storage capacity was in fact chosen to match the storage capacity of the VES in order to better compare the flexibility of the two technological solutions.

Fig. 14 shows the energy flows for the VES case (Fig. 14a) and for the EB case (Fig. 14b) in winter, in the mid-season and in summer. The flexibility offered by the two technologies is very similar for the winter and mid-season: both solutions allow the absorption of the over-production of electricity, thus increasing the REC self-consumption. On the other hand, VES is unable to offer flexibility in the summer period. In fact, when buildings do not require heating, it is not possible to shift the electrical load of the LP2H systems and therefore exploit the VES flexibility. However, EB is not affected by this constraint and its flexibility can always be used.

The energy absorbed and released by the VES and EB technologies for all the days of the year is represented in Fig. 15 to better compare the two solutions. The figure groups the energy accumulated and released as a function of the average daily temperature in which flexibility was used: for example, the sum of all the energy absorbed and released in all the days of the year in which the average daily temperature was in the 7.5–10 °C range is shown in the “7.5 – 10” interval. On days when the average outside temperature is below around 17.5 °C, the flexibility offered by the two technologies is very similar. Under these conditions, both flexible solutions can almost completely absorb the over-generations of PV (see Table 4). In general, the electric battery is able to accumulate energy more efficiently and continuously than the VES solution. On days when the average outside temperature is higher than 17.5 °C, the flexibility of the VES is drastically reduced, due to the shutdown of the heating systems. As can be seen from the data summarized in Table 4, the higher the average external temperature, the higher the mean PV over-generation. When the average external temperature is high, the daily PV over-generation saturates the storage capacity of the electric batteries. In fact, on days when the external temperature exceeds 22.5 °C, the electric battery is able to store <60% of the PV over-generation.

3.3. Self-consumption and self-sufficiency: Sensitivity analysis of PV penetration

In order to highlight the impact of flexibility on the REC under different PV penetration conditions, a sensitivity analysis was conducted

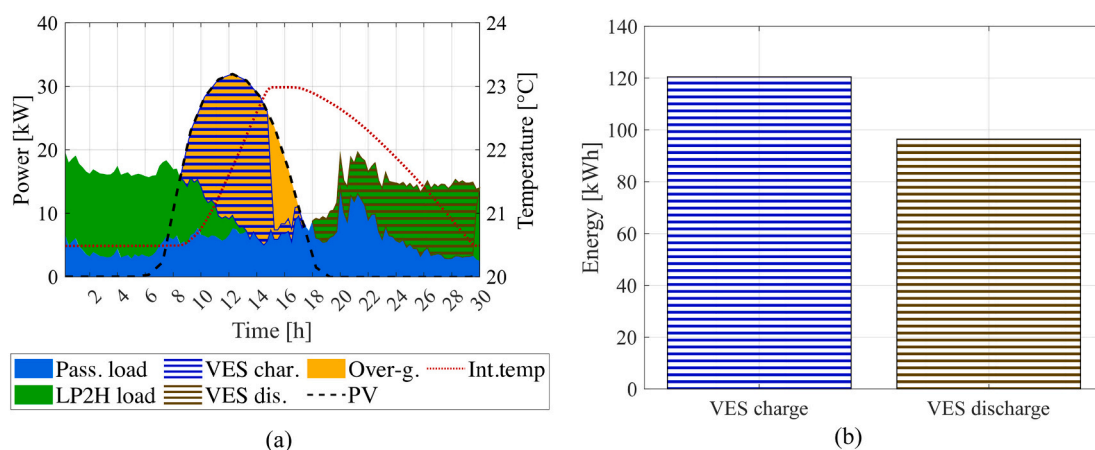

Fig. 12. The Virtual Energy Storage (VES) effect and indoor temperature of the buildings (a). VES electricity charge and discharge (b). Details pertaining to 20th April.

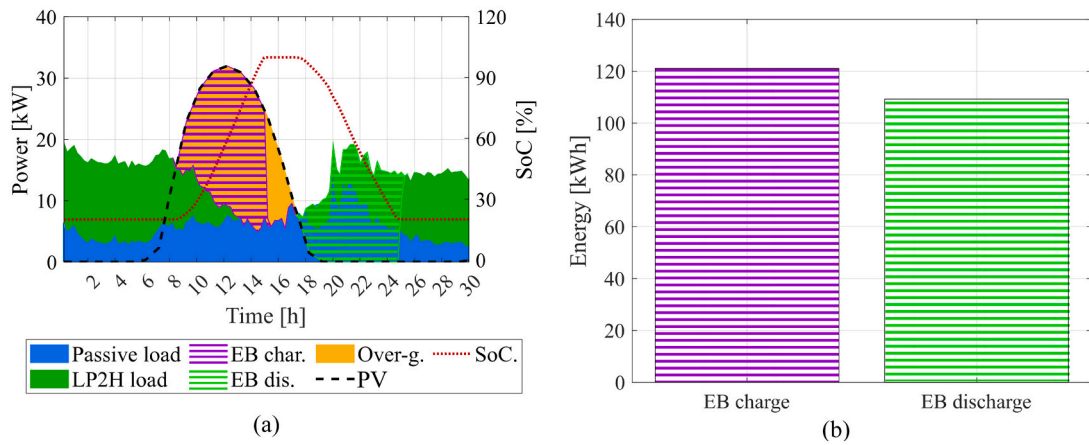

Fig. 13. Electricity balance of the renewable energy community for the EB case (a). EB electricity charge and discharge (b). Details pertaining to 20th April.

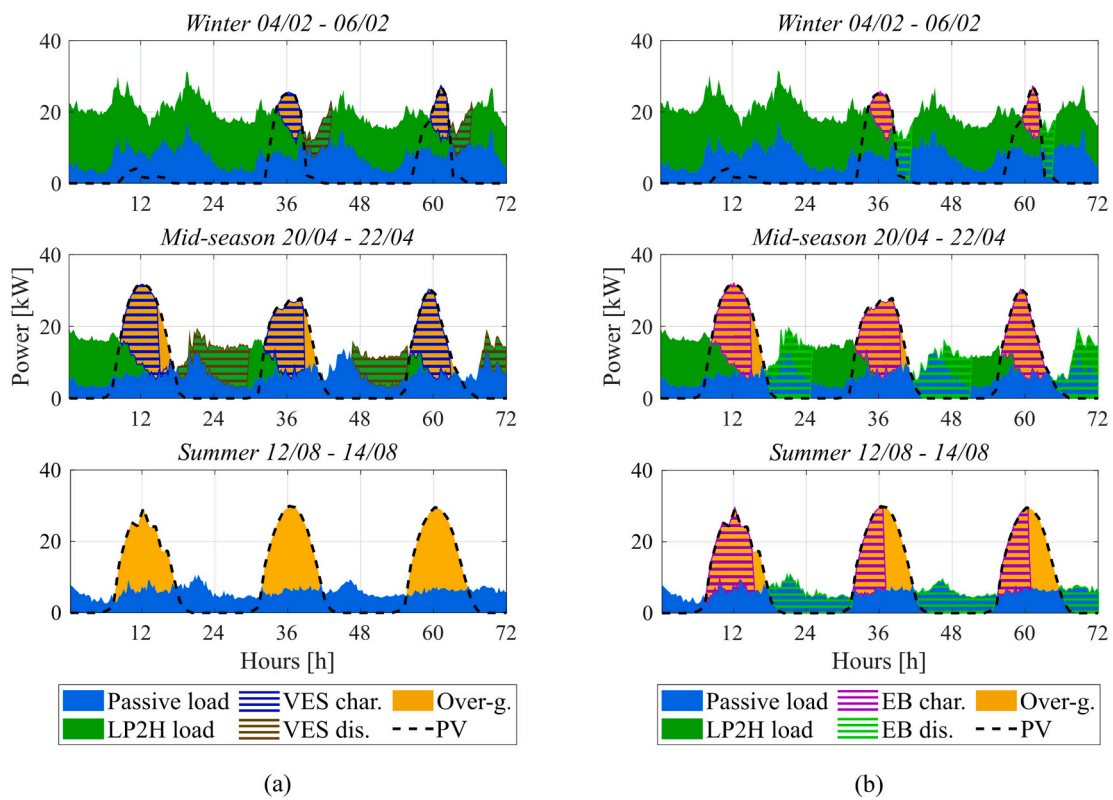

Fig. 14. Electricity balance of the renewable energy community for different seasons: the VES case (a) and the EB case (b).

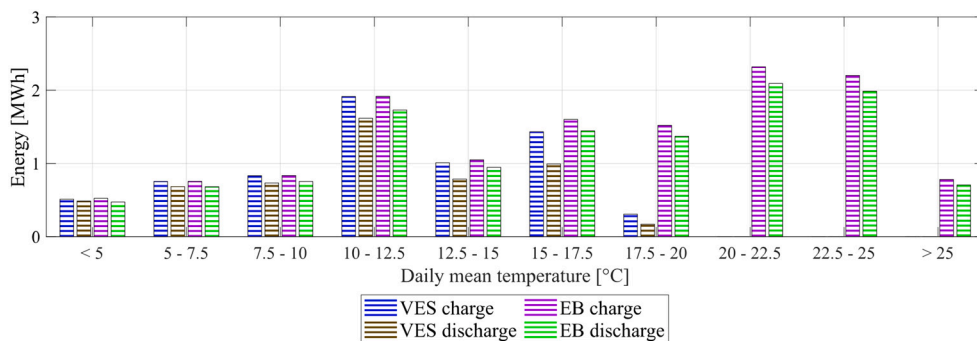

Fig. 15. Energy accumulated and released by VES and EB throughout the year divided by the average daily temperature.

Table 4

PV over-generation and over-generation absorption as a function of the external temperature.

Mean external temperature [°C]	Number of days [-]	PV over-gen. [kWh]	Mean daily PV over-gen [kWh/day]	PV absorbed by VES [%]	PV absorbed by EB [%]
< 5	81	524	6.5	100	100
5–7.5	49	756	15.4	100	100
7.5–10	35	835	23.9	100	100
10–12.5	46	1967	42.8	96	97
12.5–15	29	1113	38.4	91	94
15–17.5	34	1610	47.3	89	99
17.5–20	18	1778	98.8	17	85
20–22.5	35	2801	80.0	0	83
22.5–25	28	3707	132.4	0	59
> 25	10	1400	140.0	0	57

on the variation of the PV plant installed power. It is worth mentioning that the energy flows of the REC are not only influenced by the capacity of the PV plant, but also by the storage capacity. The VES storage capacity is constrained by the number of buildings in the energy community. The storage capacity of the electric battery can instead be modified without this kind of restriction. However, in order to compare the flexibility of the two flexible solutions under equal conditions, the electric battery capacity was chosen to be as close as possible to the VES storage capacity. For the sake of completeness, the results of a sensitivity analysis on the variation of the EB capacity are also reported in [Section 3.4.2](#).

[Table 5](#) shows the energy flows exchanged between the renewable energy community and the electricity grid on an annual basis. In particular, the following parameters are reported:

- **Electricity injection:** the electricity that is produced by the renewable energy community and injected into the grid, i.e., all the energy that is released from the EB plus all the electricity produced by the PV but not accumulated in the EB storage unit. Since the EB is directly connected to the PV plant, the electricity that is produced by the PV and sent to the EB does not pass through the grid and was therefore not included in this parameter.
- **Self-consumed electricity:** the amount of electricity injected into the grid that is consumed within the REC.
- **Electricity withdrawn:** the total amount of electricity that is consumed by the REC (it includes the self-consumed electricity).

As shown in [Table 5](#), the PV electricity injected into the grid in the VES case is the same as that in the Base case, as the LP2H systems do not interact with the PV plant. On the other hand, the centralized EB is directly connected to the photovoltaic system. When the flexibility of the EB is exploited, the PV energy surplus is not directly injected into the grid but is first accumulated inside the battery and, when the REC needs it, it is fed into the grid. The non-unitary efficiency of the battery leads to a loss of energy during storage, and the amount of electricity fed into the grid therefore decreases.

The energy consumption of the EB case (i.e., the electricity

withdrawn from the grid) is the same as that of the Base case, as the use of the electric battery does not change the REC electricity demand. On the other hand, the electricity consumption increases slightly in the VES case. This is because the flexible use of the LP2H systems leads to an increase in the building heat losses and therefore also in the electricity consumption of the heating systems.

It should be noted that the flexibility enabled by VES leads to an increase in the self-consumed energy of between 6% and 44% compared to the Base case. Specifically, the greater the PV penetration, the greater the percentage increase in self-consumed energy (in the scenario with 40 kW of PV the increase is almost 28%). An even more significant increase, between 19 and 63%, is achieved in the EB case (it is about 50% in the intermediate case with 40 kW of PV). The flexibility offered by the electric battery has a greater impact since, unlike the VES flexibility, it has fewer utilization constraints. Nevertheless, the impact of VES flexibility on the energy flows is still relevant.

The self-sufficiency and self-consumption KPIs as a function of the PV installed power are shown in [Fig. 16](#). In the scenario with 40 kW of PV, the use of the VES flexibility allows the self-sufficiency to be increased by 5 percentage points and self-consumption by 17 percentage points, compared to the Base case. In the same scenario, the use of EB allows the self-sufficiency to be increased by 10 percentage points and the self-consumption by 33 percentage points.

Moreover, as the PV penetration increases, the local energy production of the REC increases and so does the self-sufficiency. On the other hand, an increase in PV penetration leads to an increase in over-generated energy, which decreases the self-consumption KPI.

3.4. Economic analysis results

3.4.1. Sensitivity analysis of PV penetration

The annual cash flows for the three cases considering the different PV penetration scenarios are reported in [Table 6](#). As mentioned in the previous section, the use of flexible resources could slightly increase the electricity consumption of the REC (VES case) and slightly decrease the amount of PV energy fed into the grid (EB case). In addition, the use of VES causes the electricity consumption of REC to shift over time, resulting in different expenses for electricity purchases due to electricity price fluctuations throughout the day. Consequently, the costs for electricity consumption could increase slightly (VES case) and the earnings for the energy fed into the grid could decrease slightly (EB case). Moreover, in the EB case, the installation of the centralized EB leads to an increase in the operating and maintenance costs. On the other hand, the use of flexible resources significantly increases the revenue from incentives for self-consumed electricity. In the scenario with 40 kW of PV power, the revenues from the self-consumption incentives in the VES case are almost 30% higher than in the Base case; while in the EB case, the self-consumption revenues are almost 50% higher compared to the Base case. Moreover, the revenues for the self-consumed electricity increase by increasing the installed PV power.

[Fig. 17a](#) shows the total annual incomes for the VES and EB cases, computed according to [Eq. 20](#) and [Eq. 21](#). Both solutions allow the renewable energy community to improve the annual cash flow. The economic benefits of using flexible assets increase as the PV penetration

Table 5

Annual energy flow of the renewable energy community for the three cases (BC, VES and EB) considering different PV penetration scenarios.

PV [kW]	Electricity injection [MWh]			Electricity self-consumed [MWh]			Electricity withdrawn [MWh]		
	Base Case	VES Case	EB Case	Base Case	VES Case	EB Case	Base Case	VES Case	EB Case
20	20.3	20.3	19.9	16.7	17.7	19.9	121.5	121.6	121.5
30	30.4	30.4	29.5	21.1	24.5	29.2	121.5	122.1	121.5
40	40.6	40.6	39.3	24.1	30.8	36.2	121.5	122.8	121.5
50	50.7	50.7	49.1	26.3	36.1	41.5	121.5	123.4	121.5
60	60.9	60.9	58.9	28.1	40.6	45.8	121.5	123.9	121.5

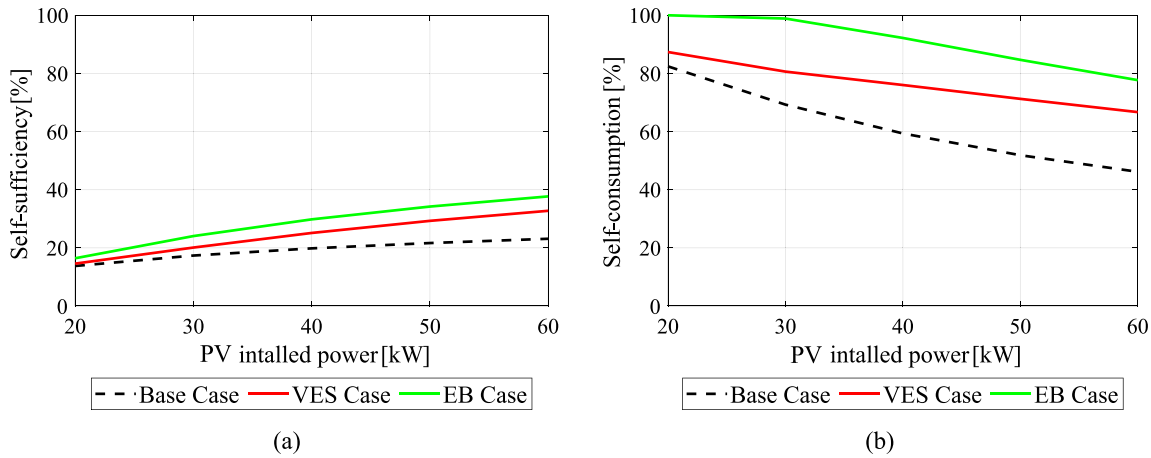

Fig. 16. Self-sufficiency KPI (a) and self-consumption KPI (b) of the renewable energy community as a function of the PV installed power.

Table 6

Annual cash flows of the renewable energy community for the three cases (BC, VES and EB) considering different PV penetration scenarios.

PV [kW]	Electricity injection revenues [€]			Total incentive revenues [€]			Withdrawn electricity expenditure [€]			Additional O&M expenditure [€]		
	BC	VES	EB	BC	VES	EB	BC	VES	EB	BC	VES	EB
20	1014	1014	997	1973	2091	2351	26,434	26,481	26,434	0	0	653
30	1521	1521	1477	2487	2894	3447	26,434	26,612	26,434	0	0	653
40	2028	2028	1963	2841	3638	4271	26,434	26,814	26,434	0	0	653
50	2535	2535	2453	3103	4263	4902	26,434	26,993	26,434	0	0	653
60	3042	3042	2947	3314	4788	5403	26,434	27,158	26,434	0	0	653

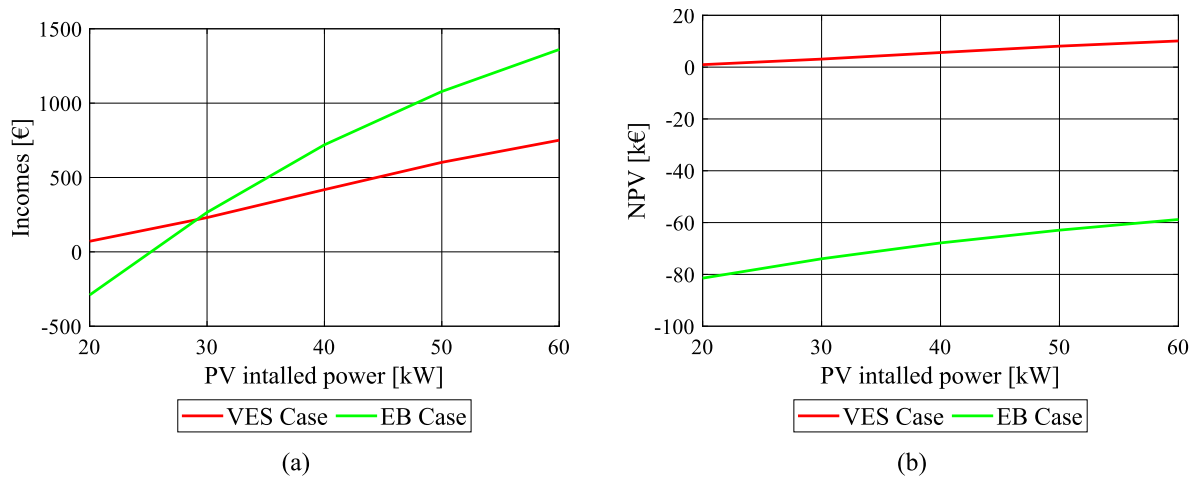

Fig. 17. REC annual incomes derived from the use of flexible assets as a function of PV installed power (a). Net Present Value of the flexible assets as a function of PV installed power (b).

increases. The EB enables greater flexibility and, consequently, the annual gains that can be achieved with such a solution are greater than those obtainable with the VES flexibility asset. However, when calculating the NPV of the two solutions (Eq. 22 and Eq. 23), it can be seen that, in the EB case, the increase in economic revenues resulting from the energy self-consumption are not sufficient to compensate for the high investment cost of the electric battery: this solution has a negative NPV (see Fig. 17b, green line). Further details regarding the economic evaluation of the EB use in an REC context are reported in Section 3.4.2. As can be observed, although the annual earnings of the VES case are lower than in the EB case, the VES solution resulted to be economically viable (a positive NPV).

3.4.2. Sensitivity analysis of the EB capacity

In the previous section, it was seen that the increase in revenues for self-consumption incentives is not sufficient to counterbalance the investment cost for a 145 kWh electric battery. In this section, a sensitivity analysis is performed by varying the EB storage capacity. Specifically, 4 additional scenarios with lower battery storage capacities were considered: 120 kWh, 90 kWh, 60 kWh and 30 kWh.

It should be noted that if the capacity of the electric battery is reduced, the annual incomes for the renewable energy community decrease (see Fig. 18a): a lower battery capacity, in fact, involves a lower level of self-consumption for the REC and, consequently, the corresponding revenue decreases. On the other hand, a lower capacity of the

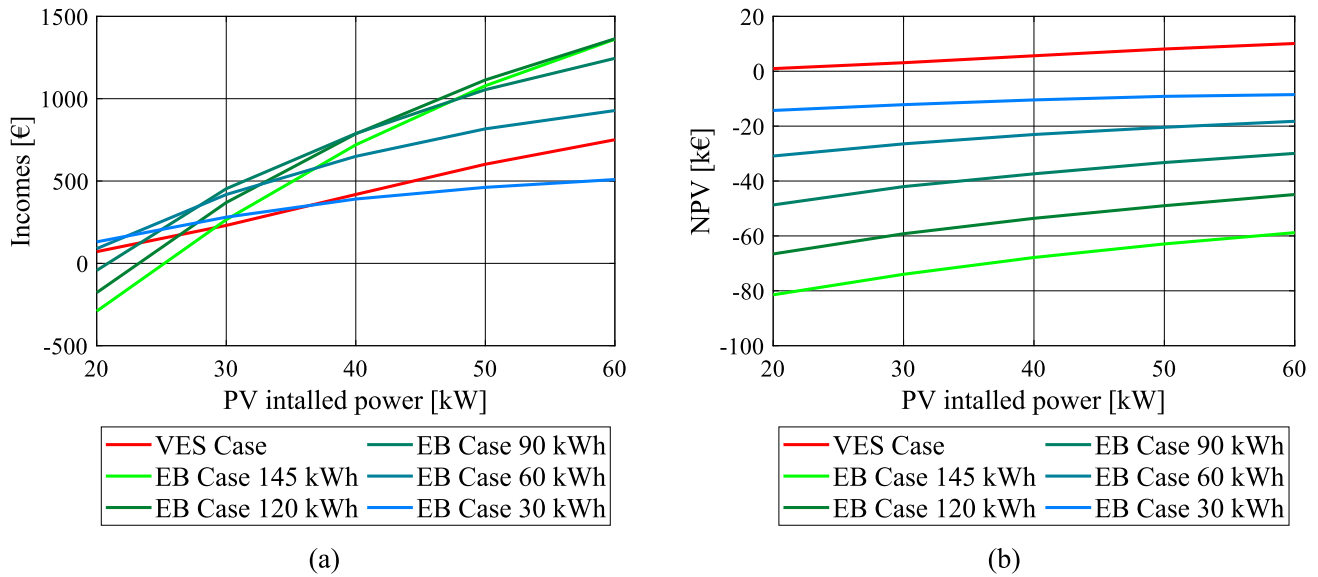

Fig. 18. REC annual incomes derived from the use of flexible assets as a function of the PV installed power and EB capacity (a). Net Present Value as a function of the PV installed power and EB capacity (b).

electric battery leads to a lower investment cost, which has a positive effect on the NPV: the lower the installed capacity of the electric battery, the higher the NPV (see Fig. 18b). Nevertheless, it can be observed that the NPV always remains negative for all cases considered.

It is worth noting that it would be technically possible to introduce a larger EB capacity within the energy community. A larger EB storage capacity would lead to an increase in flexibility and thus to an increase in the REC self-consumption. However, the economic benefits resulting from a higher level of self-consumption would not counterbalance the increase in the investment cost and would lead to a further deterioration of the NPV parameter.

As shown in [48], the cost of electric batteries is getting lower and lower every year. Therefore, an optimistic EB investment cost of 300 €/MWh was also considered. Despite this optimistic value, the use of EB to maximize self-consumption is still not economically advantageous: economic benefits derived from increased self-consumption cannot

compensate the EB investment cost (see Fig. 19).

It is worth noting that, in this analysis, both the EB and VES solutions were investigated in terms of maximizing the REC self-consumption. However, these two flexible assets can also be exploited to take advantage of variations in the electricity price over time, which will be better explored in future work.

4. Conclusions

This article analyzes the flexibility enabled by the LP2H technology, which allows the intrinsic flexibility of the heating sector to be transposed to the electricity one. This flexibility makes it possible to move part of the electrical loads necessary to heat buildings over time, according to the VES approach: in this analogy, when the load of the LP2H systems is forcibly increased, electrical energy is virtually accumulated. When this happens, the LP2H system exploits the thermal mass of the building to accumulate heat. In the hours immediately following storage, it is not necessary to use the LP2H systems as the temperature is kept within the comfort range thanks to the thermal inertia of the building. In the VES analogy, the decrease in the electricity consumption of the LP2H units is equated with a release of the electrical energy previously accumulated in the VES.

The VES solution is investigated here in an REC context and compared with an alternative flexibility asset based on an electric battery (EB). The aim is to maximize the self-consumption of on-site PV production, with consequent economic benefits due to the REC self-consumption incentives. The main conclusions of this analysis can be summarized as follows:

- During the heating season, the flexibility enabled by VES is very similar to that of an electric battery system. However, when the heating systems are not in operation, due to the warm outside temperature, the flexibility of VES cannot be exploited. In these conditions, an accumulation of thermal energy inside the building could cause a violation of the thermal comfort conditions of a building. On the other hand, electric batteries are not affected by these constraints and can be used every day of the year. In general, the flexibility enabled by an electric battery on an annual basis is greater than that made available by the VES solution. Therefore, from an energy point

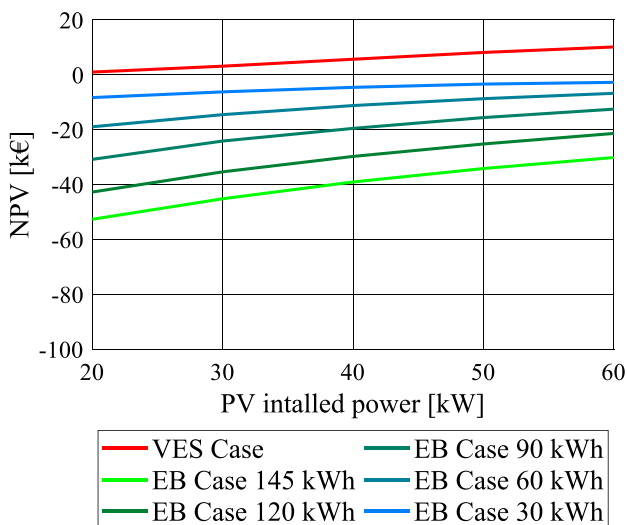

Fig. 19. Net Present Value as a function of the PV installed power and EB capacity (considering an EB CAPEX of 300 €/kWh).

of view, the benefits of installing an electric battery system are greater than those derived from the activation of VES flexibility.

- In the analyzed scenario with 40 kW photovoltaic system, the renewable energy community would achieve a self-sufficiency of 20% and a self-consumption of 59% without the use of any flexible assets. Enabling VES flexibility would improve both of these parameters. In particular, the VES solution would allow the renewable energy community to improve its self-sufficiency by 5 percentage points and its self-consumption by 17 percentage points. Instead, in the case of using a centralized electric battery, self-sufficiency would increase by 10 percentage points and self-consumption would increase by 33 percentage points compared to the case without flexible assets.
- Both the VES and EB technologies made it possible to increase the REC self-consumption of the renewable energy community to a great extent, with a consequent increase in revenues due to the REC incentives. Higher levels of self-consumption – and thus higher economic revenues – can be achieved with the EB solution compared to the VES solution. However, the profits from the increase in self-consumption of the energy community were not sufficient to compensate for the high investment cost of the electric battery. On the contrary, the VES solution, although less performing from an energy point of view, was found to be economically convenient. The higher the PV penetration, the higher the NPV of the VES solution.

Appendix

The lifetime of the battery was assessed based on the Lifetime Throughput (LT), i.e., the overall amount of energy that can flow throughout the battery before it is replaced, and the Annual Throughput (AT), i.e., the energy flowing throughout the battery over a reference year. Specifically, the LT parameter was computed starting from the lifetime curve of the battery (which is provided by the battery manufacturer), based on the methodology and input data described in [21]. The AT parameter was instead derived as follows

$$AT = \sum_{k=1}^K \left(u_{EB}(k) \cdot \eta_{EB, ch} + \frac{g_{EB}(k)}{\eta_{EB, dc}} \right) \quad (A1)$$

Once the values of LT and AT are known, the lifetime of the battery (L_{EB} , in years) can be calculated according to the following relationship:

$$L_{EB} = \min \left(\frac{LT}{AT}, N \right) \quad (A2)$$

The lifetime of the battery is needed to estimate when the EB replacement occurs over the time horizon (N) to accurately estimate the replacement (RC_{EB}) and salvage (SV_{EB}) contributions (see Eq. 23).

The EB salvage value (SV_{EB}) represents the economic value of the battery at the end of the time horizon. As shown in Eq. A3, it is assumed that SV_{EB} is directly proportional to the EB remaining life (i.e., assumption of linear depreciation).

$$SV_{EB} = RC_{EB} \frac{L_{rem, EB}}{L_{EB}} \quad (A3)$$

where $L_{rem, EB}$ (in years) is the remaining lifetime of the battery module at the end of the time horizon. It was expressed as (for $L_{EB} \neq N$):

$$L_{rem, EB} = L_{EB} - \left[N - L_{EB} \cdot INT \left(\frac{N}{L_{EB}} \right) \right] \quad (A4)$$

where INT is a function that returns the integer amount of a real number. In case $L_{EB} = N$, $L_{rem, EB}$ is set to zero.

References

- [1] European Commission, Clean energy for all Europeans, Luxembourg (Belgium) (2019), <https://doi.org/10.2833/9937>.
- [2] A. Ciocia, V.A. Boicea, G. Chicco, P. Di Leo, A. Mazza, E. Pons, F. Spertino, N. Hadj-Said, Voltage control in low-voltage grids using distributed photovoltaic converters and centralized devices, *IEEE Trans. Ind. Appl.* 55 (1) (2018) 225–237, <https://doi.org/10.1109/TIA.2018.2869104>.
- [3] A. Mazza, H. Mirtaheri, G. Chicco, A. Russo, M. Fantino, Location and sizing of battery energy storage units in low voltage distribution networks, *Energies*. 13 (1) (2019) 52, <https://doi.org/10.3390/en13010052>.
- [4] European Commission. Directive (EU) 2018/2001 of the European Parliament and of the council of 11 December 2018 on the promotion of the use of energy from renewable sources. Renewable Energy Directive n.2001/2018. Available online at: https://eur-lex.europa.eu/legal-content/EN/TXT/?uri=uriserv:OJ.L_.2018.328.01.0082.01.ENG&toc=OJ.L:2018:328:TOC.
- [5] European Commission. Directive (EU) 2019/944 of the European Parliament and of the Council of 5, On Common Rules for the Internal Market for Electricity and Amending Directive, Available online at, <https://eur-lex.europa.eu/legal-content/EN/TXT/?uri=CELEX%3A32019L0944>, June 2019.
- [6] V. Todeschi, P. Marocco, G. Mutani, A. Lanzini, M. Santarelli, Towards energy self-consumption and self-sufficiency in urban energy communities, *Int. J. Heat Technol.* 39 (2021), <https://doi.org/10.18280/ijht.390101>, 1–1.
- [7] M. Badami, G. Fambri, S. Mancò, M. Martino, I.G. Damousis, D. Agtzidis, D. Tzovaras, A decision support system tool to manage the flexibility in renewable

CRedit authorship contribution statement

Gabriele Fambri: Conceptualization, Methodology, Writing – original draft, Writing – review & editing, Software, Investigation, Data curation, Visualization. **Paolo Marocco:** Methodology, Writing – review & editing, Data curation, Investigation. **Marco Badami:** Conceptualization, Supervision, Funding acquisition, Methodology, Investigation. **Dimosthenis Tsagkrasoulis:** Writing – review & editing, Software, Validation, Investigation.

Declaration of competing interest

The authors declare that they have no known competing financial interests or personal relationships that could have appeared to influence the work reported in this paper.

Data availability

The data that has been used is confidential.

Acknowledgements

The authors would like to thank the graphic designer Michele Giusto for his help in editing the figures.

- energy-based power systems, *Energies*. 13 (1) (2020) 153, <https://doi.org/10.3390/en13010153>.
- [8] M.I. Alizadeh, M.P. Moghaddam, N. Amjadi, P. Siano, M.K. Sheikh-El-Eslami, Flexibility in future power systems with high renewable penetration: a review, *Renew. Sustain. Energy Rev.* 57 (2016) 1186–1193, <https://doi.org/10.1016/j.rser.2015.12.200>.
- [9] A.A. Kebede, T. Coosemans, M. Messagie, T. Jemal, H.A. Behabtu, J. Van Mierlo, M. Bercibar, Techno-economic analysis of lithium-ion and lead-acid batteries in stationary energy storage application, *J. Energy Storage*. 40 (2021) 102748, <https://doi.org/10.1016/j.est.2021.102748>.
- [10] H. Lund, P.A. Østergaard, D. Connolly, I. Ridjan, B.V. Mathiesen, F. Hvelplund, et al., Energy storage and smart energy systems, *Int J Sustain Energy Plan Manag.* 11 (2016) 3–14, <https://doi.org/10.5278/ijsepm.2016.11.2>.
- [11] M. Badami, G. Fambri, Optimising energy flows and synergies between energy networks, *Energy*. 173 (2019) 400–412, <https://doi.org/10.1016/j.energy.2019.02.007>.
- [12] B.V. Mathiesen, H. Lund, D. Connolly, H. Wenzel, P.A. Østergaard, B. Möller, et al., Smart energy systems for coherent 100% renewable energy and transport solutions, *Appl. Energy*. 145 (2015) 139–154, <https://doi.org/10.1016/j.apenergy.2015.01.075>.
- [13] G. Chicco, S. Riaz, A. Mazza, P. Mancarella, Flexibility from distributed multienergy systems, *Proc. IEEE* 108 (2020) 1496–1517, <https://doi.org/10.1109/JPROC.2020.2986378>.
- [14] G. Fambri, C. Diaz-Londono, A. Mazza, M. Badami, R. Weiss, Techno-economic analysis of power-to-gas plants in a gas and electricity distribution network system with high renewable energy penetration, *Appl. Energy* 312 (2022) 118743, <https://www.sciencedirect.com/science/article/pii/S0306261922001994>.
- [15] G. Fridgen, R. Keller, M.F. Körner, M. Schöpf, A holistic view on sector coupling, *Energy Policy* 147 (2020) 111913, <https://doi.org/10.1016/j.enpol.2020.111913>.
- [16] C. Diaz-Londono, L. Colangelo, F. Ruiz, D. Patino, C. Novara, G. Chicco, Optimal strategy to exploit the flexibility of an electric vehicle charging station, *Energies*. 12 (20) (2019) 3834, <https://doi.org/10.3390/en12203834>.
- [17] N. Wulff, F. Miorelli, H.C. Gils, P. Jochem, Vehicle energy consumption in Python (Vencopy): presenting and demonstrating an open-source tool to calculate electric vehicle charging flexibility, *Energies*. 14 (14) (2021) 4349, <https://doi.org/10.3390/en14144349>.
- [18] G. Fambri, C. Diaz-Londono, A. Mazza, M. Badami, R. Weiss, Power-to-Gas in gas and electricity distribution systems: a comparison of different modeling approaches, *J. Energy Storage* 15 (55) (2022), 105454, <https://doi.org/10.1016/j.est.2022.105454>.
- [19] P.A. Østergaard, A.N. Andersen, Variable taxes promoting district heating heat pump flexibility, *Energy* 15 (221) (2021), 119839, <https://doi.org/10.1016/j.energy.2021.119839>.
- [20] G. Fambri, A. Mazza, E. Guelpa, V. Verda, M. Badami, Power-to-heat plants in district heating and electricity distribution systems: a techno-economic analysis, *Energy Convers. Manag.* 15 (276) (2023), 116543, <https://doi.org/10.1016/j.enconman.2022.116543>.
- [21] P. Marocco, D. Ferrero, A. Lanzini, M. Santarelli, Optimal design of stand-alone solutions based on RES + hydrogen storage feeding off-grid communities, *Energy Convers. Manag.* ISSN: 0196-8904 238 (2021) 114147, <https://doi.org/10.1016/j.enconman.2021.114147>. <https://www.sciencedirect.com/science/article/pii/S019689042100323X>.
- [22] D. Bionaz, P. Marocco, D. Ferrero, K. Sundseth, M. Santarelli, Life cycle environmental analysis of a hydrogen-based energy storage system for remote applications, *Energy Rep.* 1 (8) (2022) 5080–5092, <https://doi.org/10.1016/j.egy.2022.03.181>.
- [23] C. Diaz-Londono, D. Enescu, F. Ruiz, A. Mazza, Experimental modeling and aggregation strategy for thermoelectric refrigeration units as flexible loads, *Appl. Energy* 272 (2020) 115065, <https://doi.org/10.1016/j.apenergy.2020.115065>.
- [24] R. D'hulst, W. Labeuw, B. Beusen, S. Claessens, G. Deconinck, K. Vanthournout, Demand response flexibility and flexibility potential of residential smart appliances: experiences from large pilot test in Belgium, *Appl. Energy* 155 (2015) 79–90, <https://doi.org/10.1016/j.apenergy.2015.05.101>.
- [25] D. Sandoval, P. Goffin, H. Leibundgut, How low exergy buildings and distributed electricity storage can contribute to flexibility within the demand side, *Appl. Energy* 187 (2017) 116–127, <https://doi.org/10.1016/j.apenergy.2016.11.026>.
- [26] G. Fambri, M. Badami, D. Tsagkrasoulis, V. Katsiki, G. Giannakis, A. Papanikolaou, Demand flexibility enabled by virtual energy storage to improve renewable energy penetration, *Energies*. 13 (19) (2020) 5128, <https://www.mdpi.com/1996-1073/13/19/5128>.
- [27] G. De Luca, I. Ballarini, A. Paragamyan, A. Pellegrino, V. Corrado, On the improvement of indoor environmental quality, energy performance and costs for a commercial nearly zero-energy building, *Science and Technology for the Built Environment*. 27 (8) (2021) 1056–1074, <https://doi.org/10.1080/23744731.2021.1940275>.
- [28] G. Reynders, J. Diriken, D. Saelens, Generic characterization method for energy flexibility: applied to structural thermal storage in residential buildings, *Appl. Energy* 198 (2017) 192–202, <https://doi.org/10.1016/j.apenergy.2017.04.061>.
- [29] K. Xie, H. Hui, Y. Ding, Review of modeling and control strategy of thermostatically controlled loads for virtual energy storage system, *Protection and Control of Modern Power Systems*. 4 (1) (2019) 1–3, <https://doi.org/10.1186/s41601-019-0135-3>.
- [30] X. Jin, Y. Mu, H. Jia, J. Wu, T. Jiang, X. Yu, Dynamic economic dispatch of a hybrid energy microgrid considering building based virtual energy storage system, *Appl. Energy* 194 (2017) 386–398, <https://doi.org/10.1016/j.apenergy.2016.07.080>.
- [31] Shi W, Liu Q, Ruan Y, Qian F, Meng H, Quantification and economic analysis of virtual energy storage caused by thermal inertia in buildings. In *Journal of physics: conference series* 2023 (Vol. 2474, no. 1, p. 012002). IOP Publishing. doi:<https://doi.org/10.1088/1742-6596/2474/1/012002>.
- [32] S.M. Hakimi, S.M. Tafreshi, Smart virtual energy storage control strategy to cope with uncertainties and increase renewable energy penetration, *J. Energy Storage*. 6 (2016) 80–94, <https://doi.org/10.1016/j.est.2016.03.001>.
- [33] Jin X, Wang X, Mu Y, Jia H, Xu X, Qi Y, Yu X, Qi F. Optimal scheduling approach for a combined cooling, heating and power building microgrid considering virtual storage system. In 2016 IEEE power and energy society general meeting (PESGM), Tianjin, China. 2016 (pp. 1-5). IEEE. doi:<https://doi.org/10.1109/PESGM.2016.7741879>.
- [34] K. Foteinaki, R. Li, A. Heller, C. Rode, Heating system energy flexibility of low-energy residential buildings, *Eng. Buildings* 180 (2018) 95–108, <https://doi.org/10.1016/j.enbuild.2018.09.030>.
- [35] L. Romero Rodríguez, J.S. Ramos, S.Á. Domínguez, U. Eicker, Contributions of heat pumps to demand response: a case study of a plus-energy dwelling, *Appl. Energy* 214 (2018) 191–204, <https://doi.org/10.1016/j.apenergy.2018.01.086>.
- [36] C. Utama, S. Troitzsch, J. Thakur, Demand-side flexibility and demand-side bidding for flexible loads in air-conditioned buildings, *Appl. Energy* 285 (2021) 116418, <https://doi.org/10.1016/j.apenergy.2020.116418>.
- [37] A. Artecioni, A. Mugnini, F. Polonara, Energy flexible buildings: a methodology for rating the flexibility performance of buildings with electric heating and cooling systems, *Appl. Energy* 251 (2019) 113387, <https://doi.org/10.1016/j.apenergy.2019.113387>.
- [38] J. Vivian, U. Chiodarelli, G. Emmi, A. Zarrella, A sensitivity analysis on the heating and cooling energy flexibility of residential buildings, *Sustain. Cities Soc.* 52 (2020) 101815, <https://doi.org/10.1016/j.scs.2019.101815>.
- [39] J. Lizana, D. Friedrich, R. Renaldi, R. Chacartegui, Energy flexible building through smart demand-side management and latent heat storage, *Appl. Energy* 230 (2018) 471–485, <https://doi.org/10.1016/j.apenergy.2018.08.065>.
- [40] C. Finck, R. Li, R. Kramer, W. Zeiler, Quantifying demand flexibility of power-to-heat and thermal energy storage in the control of building heating systems, *Appl. Energy* 209 (2018) 409–425, <https://doi.org/10.1016/j.apenergy.2017.11.036>.
- [41] A. Balint, H. Kazmi, Determinants of energy flexibility in residential hot water systems, *Energy and Build.* 188 (2019) 286–296, <https://doi.org/10.1016/j.enbuild.2019.02.016>.
- [42] European Parliament, EPBD Recast e Energy Performance of Buildings Directive. Directive 2010/31/EU of the European Parliament and of the Council of the European Union, European Parliament, 2010.
- [43] European Commission. Photovoltaic geographical information system (PVGIS) portal. Available online at: https://re.jrc.ec.europa.eu/pvg_tools/it/#PVP.
- [44] RSE. Gli schemi di Autoconsumo Collettivo e le Comunità dell'Energia. Available online at: <https://cdn.qualenergia.it/wp-content/uploads/2020/10/Schemi-di-Autoconsumo-Collettivo-e-Comunita-dell-Energia.pdf>.
- [45] Ministero dello sviluppo economico. Individuazione della tariffa incentivante per la remunerazione degli impianti a fonti rinnovabili inseriti nelle configurazioni sperimentali di autoconsumo collettivo e comunita' energetiche rinnovabili. Gazzetta Ufficiale della Repubblica Italiana. Available online at: <https://www.gazzettaufficiale.it/eli/id/2020/11/16/20A06224/sg>.
- [46] Autorità di Regolazione per Energia Reti e Ambiente. Prezzi e tariffe. Available online at: <https://www.arera.it/it/prezzi.htm>.
- [47] E. Psimopoulos, E. Bee, J. Widén, C. Bales, Techno-economic analysis of control algorithms for an exhaust air heat pump system for detached houses coupled to a photovoltaic system, *Appl. Energy* 249 (2019) 355–367, <https://doi.org/10.1016/j.apenergy.2019.04.080>.
- [48] I. Tsiropoulos, D. Tarvydas, N. Lebedeva, Li-ion Batteries for Mobility and Stationary Storage Applications, Publications Office of the European Union, 2018, <https://doi.org/10.2760/87175>.
- [49] O. Schmidt, A. Hawkes, A. Gambhir, I. Staffell, The future cost of electrical energy storage based on experience rates, *Nat. Energy* 2 (8) (2017) 1–8, <https://doi.org/10.1038/energy.2017.110>.
- [50] M. Hocking, J. Kan, P. Young, C. Terry, D. Begleiter, Lithium 101 F.I.T.T. for investors Welcome to the Lithium-ion Age, Deutsche Bank Market Research (2016) 1–179. ISBN: 1055100898643, https://pdf.dfcw.com/pdf/H3_AP201605090014764304_1.PDF.
- [51] B.D. Frankel, S. Kane, C. Tryggstad, The New Rules of Competition in Energy Storage, McKinsey & Company, 2018. Available online at: <https://www.mckinsey.com/industries/electric-power-and-natural-gas/our-insights/the-new-rules-of-competition-in-energy-storage>.
- [52] A. Eller, D. Gauntlett, Energy storage trends and opportunities in emerging markets, Navigant Consulting Inc, Boulder, CO, USA, 2017. Available online at: <https://www.esmap.org/sites/default/files/esmap-files/7151-IFC-EnergyStorage-eport.pdf>.
- [53] IRENA. Electricity storage and renewables: Costs and markets to 2030. IRENA. 2018. Available online at: <https://www.irena.org/publications/2017/Oct/Electricity-storage-and-renewables-costs-and-markets#RestrictedModal>.

- [54] P. Marocco, M. Gandiglio, M. Santarelli, When SOFC-based cogeneration systems become convenient? A cost-optimal analysis, *Energy Rep.* 1 (8) (2022) 8709–8721, <https://doi.org/10.1016/j.egy.2022.06.015>.
- [55] A. Sadiqa, A. Gulagi, C. Breyer, Energy transition roadmap towards 100% renewable energy and role of storage technologies for Pakistan by 2050, *Energy*. 147 (2018) 518–533, <https://doi.org/10.1016/j.energy.2018.01.027>.
- [56] E. Kötter, L. Schneider, F. Sehnke, K. Ohnmeiss, R. Schröer, The future electric power system: impact of power-to-gas by interacting with other renewable energy components, *J. Energy Storage*. 5 (2016) 113–119, <https://doi.org/10.1016/j.est.2015.11.012>.
- [57] L. Gracia, P. Casero, C. Bourasseau, A. Chabert, Use of hydrogen in off-grid locations, a techno-economic assessment, *Energies*. 11 (11) (2018) 3141, <https://doi.org/10.3390/en11113141>.