

Supporting a “Glocal” Energy Transition: from Local Energy Communities to Global Simulation Networks

Original

Supporting a “Glocal” Energy Transition: from Local Energy Communities to Global Simulation Networks / Benedetto, G.; Mazza, A.; Pons, E.; Bompard, E.; De Paola, A.; Thomas, D.; Kotsakis, E.; Fulli, G.; Vogel, S.; Monti, A.; Bruno, S.; Giannoccaro, G.; Scala, M. La; Bonfiglio, A.; Invernizzi, M.; Rossi, M.; De Caro, F.; Villacci, D.. - ELETTRONICO. - (2023), pp. 1-6. (2023 International Conference on Smart Energy Systems and Technologies (SEST) Mugla, Turkiye 04-06 September 2023) [10.1109/SEST57387.2023.10257451].

Availability:

This version is available at: 11583/2982948 since: 2024-08-14T10:04:45Z

Publisher:

IEEE

Published

DOI:10.1109/SEST57387.2023.10257451

Terms of use:

This article is made available under terms and conditions as specified in the corresponding bibliographic description in the repository

Publisher copyright

IEEE postprint/Author's Accepted Manuscript

©2023 IEEE. Personal use of this material is permitted. Permission from IEEE must be obtained for all other uses, in any current or future media, including reprinting/republishing this material for advertising or promotional purposes, creating new collecting works, for resale or lists, or reuse of any copyrighted component of this work in other works.

(Article begins on next page)

Supporting a “glocal” energy transition: from local energy communities to global simulation networks

G. Benedetto, A. Mazza, E. Pons,
E. Bompard

*Department of Energy “Galileo Ferraris”
Politecnico di Torino & G-RTS Lab
Turin, Italy
andrea.mazza@polito.it*

A. De Paola, D. Thomas, E. Kotsakis,
G. Fulli

*Smart Grid Interoperability Laboratory
Joint Research Centre - European Commission
Ispra, Italy
antonio.de-paola@ec.europa.eu*

S. Vogel

*OPAL-RT Germany
Aachen, Germany
steffen.vogel@opal-rt.com*

A. Monti

*Institute for Automation of Complex Power Systems
RWTH Aachen University
Aachen, Germany
amonti@eonerc.rwth-aachen.de*

S. Bruno, G. Giannoccaro, M. La Scala

*Department of Electrical & Information Engineering
Politecnico di Bari & LabZERO
Bari, Italy
sergio.bruno@poliba.it*

A. Bonfiglio, M. Invernizzi, M. Rossi

*Electrical, Electronics & Telecom. Eng.
and Naval Architecture Dep.
Università di Genova
Genoa, Italy
mansueto.rossi@unige.it*

F. De Caro

*Department of Engineering
Università del Sannio
Benevento, Italy*

D. Villacci

*Department of Industrial Engineering
Università di Napoli “Federico II”
Naples, Italy*

fdecaro@unisannio.it

domenico.villacci@unina.it

Abstract—Managing a large share of non-dispatchable renewable energy sources requires new approaches, which have to be integrated with existing and well-established control systems currently used to guarantee power system operation. In this context, the number of energy communities is expected to increase, and hence their effective integration is fundamental. This paper aims at assessing the role and impact of energy communities on the operation of a transition power system, still having a share of active traditional power plants. Simulation models and real hardware have been included in the experiment, based on a live real-time co-simulation. The results highlight both the significant contribution that the methodology (i.e., geographically-distributed real-time co-simulation) can give in informing and driving energy transition policies and the important role that energy communities may have in supporting the transition towards completely de-carbonized power systems.

Index Terms—Real Time Co-simulation, Power Hardware-in-the-Loop, Software-in-the-Loop, Control-in-the-Loop, Frequency Control.

I. INTRODUCTION

In the framework of the energy transition, the shift from fossil primary sources to Renewable Energy Sources (RES) is needed. In fact, in the last years, the awareness about the effects of climate change increased in public opinion, leading policymakers to introduce new frameworks for increasing the share of RES in the whole energy system, through both the electrification of the consumptions [1] and the use of

sector coupling [2]. The RES-based plants, depending on their controllability, can be either dispatchable (e.g., hydropower plants) or non-dispatchable (ND-RES), such as wind (WD) and photovoltaic (PV) power plants. The installation of RES capacity within the electrical system basically follows two different, and non-mutually-exclusive, approaches. One possibility (also known as the *supergrid* paradigm) considers the installation of a relatively low number of large RES power plants connected to the transmission system [3]. Alternatively, the *microgrid* paradigm implies the presence of a large number of distributed RES-based generators connected at the distribution level [4]. The latter is particularly interesting because it opens to the possibility of creating local Renewable Energy Communities (RECs) and of directly engaging customers (mostly in aggregate form) in the management and operation of the power system. RECs can provide direct benefits to citizens in the form of increased energy efficiency and lower electricity bills and, at the same time, can provide flexibility to the electricity system by offering demand-response (thanks to the proper exploitation of the generation and storage facilities of the REC). In Europe, the concept of REC has been recognized in legislation as a significant way to promote the energy transition. Indeed, the “Clean Energy Package for all Europeans” [5] introduced, in addition to the concept of Citizens Energy Communities (CEC), the main characteristics of the

RECs: in particular, the RECs must be defined close to the installed RES facilities, owned and developed by the REC itself. The change of paradigm is evident: the RES power plants are actively involved in the REC management and operation and are not external entities simply connected by chance to the same portion of the grid. Before the publication of the European directives certain countries, such as Austria, Germany, UK, and Denmark, already introduced in their legislative framework the notion of *energy cooperatives*, with the aim of fostering the involvement of the final customers in the power system operation [6].

In order to facilitate the integration of RECs within the power system, it is crucial to understand their impact and exploit their full potential. Due to the diversity of the facilities potentially operating within the RECs, their modeling can require different competencies and backgrounds which may not all be available within a single research group. For this reason, this paper pools the expertise and infrastructures of different European laboratories and adopts the Geographical Distributed Real-Time co-Simulation (GD-RTS) paradigm to study the interactions between the power system and the RECs in the energy transition framework.

A transition scenario is analyzed, where traditional power plants still exist, even though part of them have been previously decommissioned, thus reducing the control capability of the overall system. In this scenario, the use of GD-RTS has also the advantage to introduce real hardware, software and control systems within the experiment, by exploiting the so-called Power Hardware- (PHIL), Hardware- (HIL), Software- (SIL), and Control-in-the-Loop (CIL) configurations. This paper pioneers the integration of RECs into the co-simulation framework, allowing for the analysis of their operations together with the bulk system. Furthermore, the paper proposes the framework as a basis for establishing REC aggregators, aiming to create a Digital Twin of the specific portion of the system where the RECs are connected. By doing so, they enable the study of the system's evolution by exchanging only the necessary information at the Point of Common Coupling between the RECs and the main grid, rather than transmitting models or network parameters, which are sensitive data.

The remainder of the paper is structured as follows: Section II presents the basics of real-time simulation and geographical distribution co-simulations. Section III details the experimental setup, while Section IV discusses the experimental results. Finally, Section V highlights the most relevant insights and outlines future research directions in this real-time co-simulation field.

II. REAL-TIME SIMULATION AND GEOGRAPHICAL DISTRIBUTION CO-SIMULATION

Real-time (RT) simulation represents a fundamental tool to accelerate technological development and the decarbonisation of electrical power systems. The use of RT approaches allows the design and testing of new devices components in a safe and reliable environment, ensuring at the same time high accuracy and flexibility [7]. In the last few years, the

RT paradigm has been extended through different GD-RTS implementations in order to overcome some of its original limitations and extend its field of applicability [8]. The use of geographically-distributed approaches can overcome the computational limitations of traditional single-site RT by combining the hardware resources of multiple labs. At the same time, GD-RTS facilitates the pooling of expertise and collaboration between different research facilities and private companies, which can share their knowledge and experience while maintaining full control of their proprietary models. Successful GD-RTS implementations at various geographical scales and with different scopes have been presented recently. Examples in such a sense range from national studies [9] to continental [10] and intercontinental [11] experimental setups. GD-RTS approaches have been successfully applied in many different contexts, such as frequency regulation in large transmission systems [12], [13], voltage regulation of distribution networks [14] and control of microgrids [11].

In the literature, few examples of HIL co-simulation applied to the management of energy communities can be found. The authors in [15] have tested a blockchain-based decentralized control architecture for energy communities in a HIL environment. In this case, however, only a single RT simulator (RTDS) interacted with multiple Raspberry-PI controllers, all located in the same laboratory and each emulating a single blockchain node. An RT co-simulation environment was proposed in [16] to study the effects of a large-scale deployment of energy management systems for prosumers and electric vehicles. The co-simulation was obtained by developing a middleware based on relatively slow internet-based communication (MQTT, namely Message Queuing Telemetry Transport). In both [15], [16] no geographically distributed resources nor power hardware devices were employed.

In [17], an actual GD-RTS was used to test the interaction of two local energy communities connected to the same transmission network. For these tests, multiple RT simulators (OPAL and RTDS) located in two laboratories in Germany were employed. VILLASframework was used to exchange dynamic phasors information between the two RT laboratories. The study did not include hardware or power equipment and showed the limitations of using controlled current source models in the presence of relevant communication latency (latency ranged from 10 to 100 ms at a physical distance of only 250 km).

In this work, GD-RTS was used to integrate the response of multiple RT simulation nodes (six laboratories in Italy and one in Germany) in the same simulation environment. Each laboratory contributed to the overall simulation by sharing its own resources in terms of computation (SIL), control equipment (CHIL), and power hardware devices (PHIL). The sharing of these resources allows to represent complex global scenarios where the real-time evolution of multiple systems and subsystems, such as transmission and distribution networks, microgrids, and energy communities, is strictly intertwined.

The simulations were carried out relying on the VILLAS-framework and in the presence of relevant geographical dis-

tances. Communication between VILLASnodes was organized using a star network with a hub in Turin. Distances from this hub ranged from a few hundred to a thousand kilometers. Latency with one of the farthest nodes (Bari at about 1000 km) was assessed in just about 12 ms [18].

III. EXPERIMENTAL SETUP

A. Power system layout

The simulated power system aims to represent a *transitional* system, where a part of the traditional generation has been dismissed. In fact, even though the system is based on the CIGRE 12-bus transmissions system [19] shown in Fig. 1, the traditional generator installed at nodes 10 and 12 have been modified, as shown in Table I.

These modifications have an impact on the system inertia, reducing its capability to face and overcome sudden power unbalances. Hence, for preserving the capability of the system to securely operate, new resources and support features must be included. In particular, the test case includes, beyond inertia support from wind power plant as in [13], two RECs, with a twofold aim: i) verify their potential support to the bulk power system and ii) demonstrate their capacity to overcome major contingencies in the transmission system thanks to their islanding capabilities.

The conceptual scheme of the experimental setup is shown in Fig. 2.

The experimental setup represents a unique co-simulation composed of different subsystems connected to the transmission system by power transformers. The transmission system is hosted at G-RTS Lab at Politecnico di Torino and simulated on an OPAL RT5600.

About the simulated subsystems, they are hereby briefly described:

- Wind farm equipped with an inertial controller. A wind farm with nominal power $P = 260$ MW is emulated in

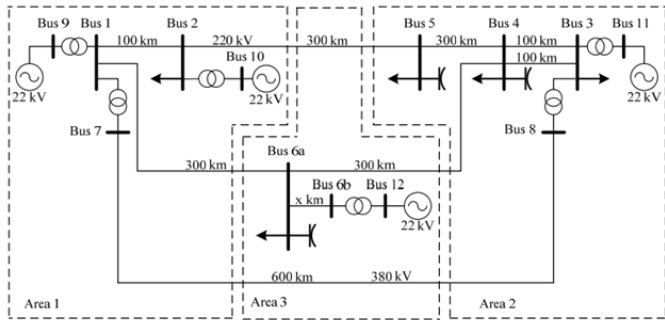

Fig. 1. 12-bus CIGRE transmission system [19].

TABLE I

MODIFICATIONS APPLIED TO THE INSTALLED TRADITIONAL GENERATION

Node	S_{orig} (MVA)	S_{mod} (MVA)
10	700	350
12	500	250

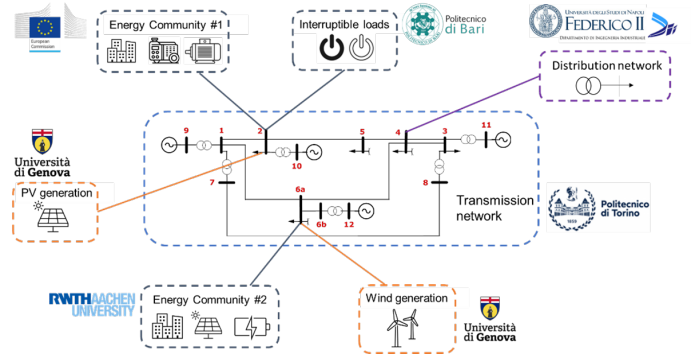

Fig. 2. Co-simulation layout.

University of Genoa Speedgoat real time simulator that includes in the simulation in a HIL fashion a prototype of an innovative inertial controller developed by UNIGE research team [20]. Its inertial controller enables to temporarily generate extra power by slowing down the rotating shafts of the generator, thus reducing the Rate of Change of Frequency (RoCoF) of critical frequency events whenever it reaches the threshold of 0.5 Hz/s. University of Genoa (main campus) simulates it.

- Energy communities of type #1. It groups 40 small RECs, each one obtained by starting from a single feeder of the Banshee distributed network benchmark [21] and equipped with a synchronous generator (either hydro or diesel) and an asynchronous motor. In steady-state conditions, the RECs withdraw a total of 39.86 MW and 69.73 Mvar. The communities have the capability of disconnecting from the main network in case of frequency events (to mitigate frequency transients in the main grid) while continuing to operate in islanded mode. In the implemented logic, the RECs are disconnected when the network frequency reaches the critical value of 49.5 Hz and are reconnected back after the frequency is restored to at least 49.95 Hz. These RECs are simulated in the Smart Grid Interoperability Laboratory at JRC Ispra.
- Photovoltaic generation. It is the replication of an actual photovoltaic system installed in the Smart Polygeneration Microgrid (SPM) of the University of Genoa (Savona campus). The real-time measures from an 80 kWp photovoltaic field installed in the SPM, once properly scaled, were used to emulate a PV power injection in the transmission network of about 30 MW.
- Energy community of type #2: It groups 25 small RECs, derived from a different feeder of the Banshee distributed network benchmark [21] and equipped with PV generation and a battery storage system. The exploitation of PV generation and storage enables to operate this part almost independently with respect to the main system: in fact, in steady-state conditions, this group of ECs withdraws around 0.1 MW and 18.5 Mvar. Given the negligible amount of power absorbed from the main grid, these RECs have limited frequency regulation ca-

pabilities. However, they can still disconnect from the transmission network and operate in islanded mode to preserve the power supply to their members in scenarios where the main network frequency reaches critical values. In the implemented logic, the RECs are disconnected when the network frequency reaches the critical value of 49.5 Hz and are reconnected back after the frequency is restored to at least 49.92 Hz. These RECs are simulated in the RWTH Aachen laboratory.

- Microgrid with interruptible loads: Microgrid equipped with a load-shedding logic and simulated within a PHIL setup. The implemented demand response system is able to automatically reduce the grid load by 25 MW when the frequency value reaches the threshold of 49.5 Hz. The load is automatically reconnected at 49.9 Hz. The LabZero of Politecnico di Bari manages it.
- Traditional MV distribution grid, simulated by the University of Naples “Federico II”.

The different partners exchange only the boundary variables required for running the simulation (and not the details of each subsystem). In the proposed framework, the transmission network and the different distribution elements are connected with an asynchronous AC coupling using an Ideal Transformer Model (ITM), as described for example in [22]. The voltage signals (in terms of amplitude and frequency) measured in the transmission network at the points of connection are exchanged and used in the simulation of the different distribution elements. In turn, the active and reactive power measured at the points of connection at the distribution level are sent to the transmission network, where they are considered as parameters of PQ dynamic loads. Details on the IT and communication implementation of this setup are provided in Section III-B.

B. Interconnection of Digital Real-time simulators

As mentioned before, the scenario presented in this paper has been carried out using a GD-RTS involving a total of six digital real-time simulators (DRTS) which were interconnected via the Internet. More precisely, the national research networks (GARR for Italy and DFN for Germany) as well as the European Géant network were used [23]. The connections between the DRTS were realized with the help of VILLAS-framework (VILLAS) [24], which is an established tool in the area of the GD-RTS and which is an Open Source software.

VILLAS, short for *Virtually Interconnected Laboratories for Large systems Simulation/emulation*, is a set of software tools enabling the exchange and visualization of simulation signals.

Two components of the framework were used in this demonstration:

- *VILLASnode*, which is a gateway for data exchange and mediates between the involved actors by forwarding data, collecting statistics and translating between different formats.
- *VILLASweb*, which is a web interface that can present the current state of the simulation to a wider public through interactive dashboards.

A total of six instances of the VILLASnode gateway were used, one in each participating laboratory on a real-time optimized Linux operating system. To ensure the time-critical exchange of simulation signals, the VILLASnode gateway was optimized for real-time execution. For example, payload data is separated from its metadata and transmitted using a binary floating point encoding via the User Datagram Protocol (UDP) to ensure minimal packet sizes. Based on the topology of the electrical network, the communication of the VILLASnode gateways was also chosen to be a star topology with its core at the G-RTSLab at Politecnico di Torino. Data-rate between the sites has been between 100 to 1000 samples/s for the co-simulation interface signals and 20 samples/s for visualization data.

The visualization of the real-time simulation data was realized by VILLASweb, which has been deployed on a publicly accessible Kubernetes cluster at RWTH Aachen University. This global access to the visualization dashboard enabled all participating labs to follow the state of the simulation in real-time and observe their coupling status. At the same time, it was possible to influence the coupling and parameters of the simulation via control widgets. Fig. 2 as well as the result plots have been directly generated from the web dashboard. Apart from the real-time data feed, VILLASweb can be used for controlling the DRTS as well as archiving models and results in a relational database and object-store.

Fig. 3 shows an overview of the VILLASframework components and their integration. Finally the security of the connection has been ensured by the implementation of the Internet Protocol Security (IPsec) protocol, providing robust security features to ensure the confidentiality, integrity, and authenticity of the communication over the network. The protocol incorporates integrity checks, to verify that the data packets have not been tampered during transmission. This ensures the integrity of the communication, protecting against any modifications or alterations by unauthorized parties. An authentication process is also present, ensuring that we are communicating with trusted devices, guarding against man-in-the-middle attacks. IPsec also includes anti-replay protection, which prevents attackers from intercepting and re-transmitting data packets.

IV. EXPERIMENTAL RESULTS

The scenario simulated in the present work considers an emergency condition in the transmission network that arises from an abrupt equivalent load increase of 250 MW, corresponding to about 17% of the entire system load. This implies a sudden frequency variation that, without suitable control strategies and resources, would lead to instability conditions and hence to a blackout.

The purpose of the experiment is to demonstrate the capability of GD-PHIL setups to support the design and analyses of the future decarbonized power system, accounting for its increased complexity and for the impact of new technologies and operational approaches. In particular, the experiment assesses the capability of energy communities and more generally

renewable energy sources to support a safe operation of the electric network by providing additional frequency regulation resources to a decarbonized power system where part of the traditional generation park has been dismissed. To test such capability, the 250MW load increase is introduced at bus 2 at time $t = 20:25$. The resulting frequency dynamics at different points of the simulated network are shown in Fig. 4. Following the load increase, the network frequency initially drops at all the considered points of the network. At $t = 20:32$, when the frequency reaches the threshold value of 49.5 Hz, the first differences arise: the frequency continues its decrease and reaches the nadir value of about 49.3 Hz in the sections of the distribution network that remains synchronized with the transmission system (i.e. Genova, Bari, Napoli), with small but noticeable spatial differences in the frequency dynamics that the simulation is able to properly capture. At the same time, the energy communities simulated in Ispra and Aachen disconnect from the main grid and begin to operate in islanded mode, maintaining constant frequency values of 49.5 and 50 Hz, respectively. The disconnection of the communities, made possible by their renewable energy sources and storage devices, ensures the energy security of the community members and, at the same time, contributes to the system frequency regulation as it reduces the overall system demand. After reaching the nadir, the network frequency gradually recovers and the secondary regulator operating at the transmission level ensures that the frequency converges to its nominal value of 50 Hz. As the threshold values of 49.92 and 49.95 Hz are reached, the energy communities in Aachen and Ispra are reconnected and synchronized again with the main grid. Frequency spikes in the figure denotes the discontinuity in the control strategy for the two communities but, as one can notice, they are irrelevant with respect to the grid frequency transient that is modelled in the Polito node.

The frequency regulation effort and the resulting power variation of the two connected renewable generation sources are shown in Fig. 5: note that the photovoltaic generation in Savona does not contribute to frequency regulation and its power generation remains approximately constant during the considered event. Conversely, the wind farm emulated in

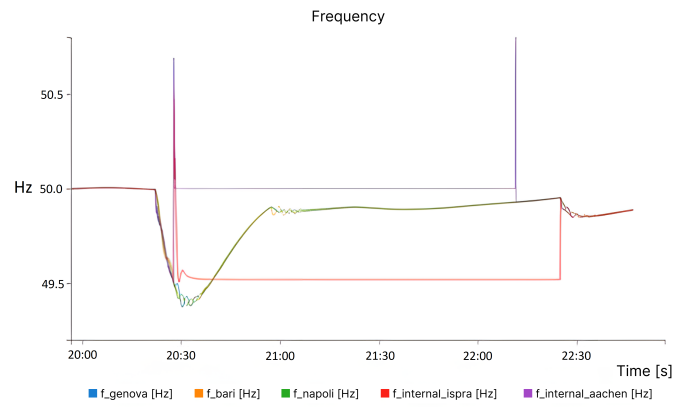

Fig. 4. Network frequency at the different network buses.

Genova provides inertial support and temporarily increases its power generation immediately after the frequency event at $t = 20:32$ by releasing part of the kinetic energy of its rotating shafts. The power exchanges between the transmission grid and the interconnected load elements at the distribution level are shown in Fig. 6: in the case of the distribution grid simulated in Napoli (blue trace), no specific control action is taken and the absorbed power remains approximately equal to about 35 MW during the whole simulation. The net power exchange with the energy communities in Aachen is approximately equal to zero at the beginning of the simulation, as the communities are able to satisfy their energy requirements by exclusively relying on their local renewable energy sources and battery storage. On these bases, even though the group of ECs of type #2 are disconnected during the frequency event, there is no relevant change in their net power flow with the transmission grid. Conversely, the microgrid operating in Bari participates in the frequency regulation with its 25 MW interruptible load, which is disconnected when the network frequency reaches the threshold value of 49.5 Hz, thus reducing the overall load of the microgrid to around 5 MW. The load is then reconnected once the network frequency goes above the threshold of 49.5 Hz at $t = 20:55$. A similar

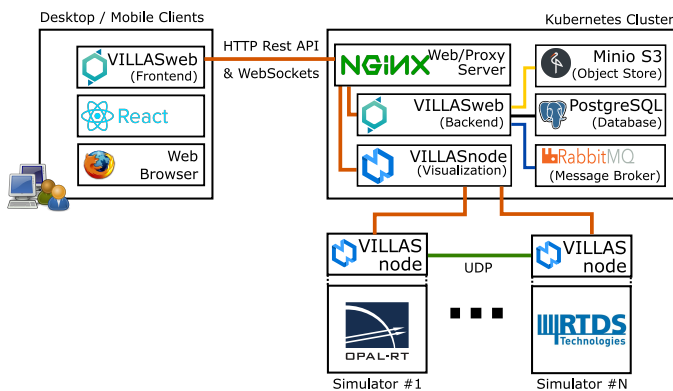

Fig. 3. VILLASframework architecture.

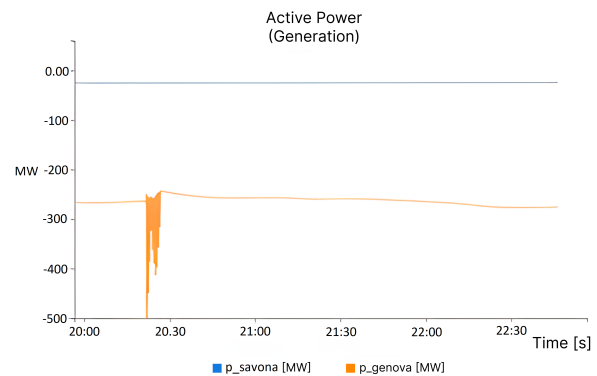

Fig. 5. Power generation of the connected renewable sources.

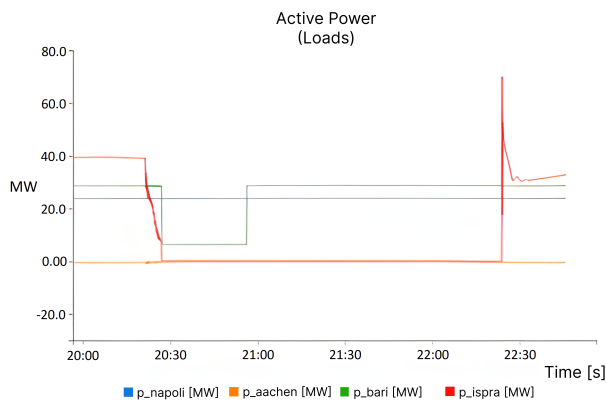

Fig. 6. Power consumption of the connected loads and renewable energy communities.

behavior can be seen for the energy community simulated in Ispra, which reduces the total system load by about 40 MW as it disconnects from the grid and begins to operate in islanded mode during the frequency event. The co-simulation has been recorded and can be accessed here [25].

V. CONCLUSION

This work describes the software and hardware set-up used to establish a collaborative co-simulation platform for studies on the exploitation of energy communities, or other forms of aggregated flexible resources, during network operations. Particularly, the geographically distributed real-time co-simulation platform can operate at a continental scale by sharing simulation resources of seven RTS laboratories (one located in Germany and six located across the Italian peninsula), integrating the cyber and/or physical response of their equipment in the same simulation environment. Sharing research equipment and resources is essential to achieve a realistic representation of complex cyber-physical systems where multiple grids, subsystems, controllers, and power devices must interact.

The experimental results were obtained during a real-time co-simulation experiment with the participation of all seven laboratories and showed how the combined actions of wind farm inertial control, energy communities islanding and load curtailment can support the power grid during severe frequency transient events. The combined effect of these control actions was assessed through the integration of the real-time response of simulated networks and microgrids (SIL), real-time controllers (HIL/CHIL), and power devices (PHIL).

The results can be considered a proof-of-concept for both the capabilities offered by the geographically distributed co-simulation approach and the innovative grid services and control strategies which can be analyzed thanks to it.

REFERENCES

- [1] R. Pinto *et al.*, "The rise and stall of world electricity efficiency:1900–2017, results and insights for the renewables transition," *Energy*, vol. 269, p. 126775, 2023.
- [2] G. Fridgen, R. Keller, M.-F. Körner, and M. Schöpf, "A holistic view on sector coupling," *Energy Policy*, vol. 147, p. 111913, Dec. 2020.
- [3] F. Schettler *et al.*, "Roadmap to the supergrid technologies," Friends of the SuperGrid, 2012.
- [4] R. Lasseter *et al.*, "Integration of distributed energy resources. The CERTS Microgrid Concept," Lawrence Berkeley National Lab. (LBNL), Berkeley, CA (United States), Tech. Rep. LBNL-50829, Apr. 2002. [Online]. Available: <https://www.osti.gov/biblio/799644>
- [5] "Clean energy for all Europeans package." [Online]. Available: https://energy.ec.europa.eu/topics/energy-strategy/clean-energy-all-europeans-package_en
- [6] R. Trevisan, E. Ghiani, and F. Pilo, "Renewable Energy Communities in Positive Energy Districts: A Governance and Realisation Framework in Compliance with the Italian Regulation," *Smart Cities*, vol. 6, no. 1, pp. 563–585, Feb. 2023.
- [7] J. Montoya *et al.*, "Advanced laboratory testing methods using real-time simulation and hardware-in-the-loop techniques: A survey of smart grid international research facility network activities," *Energies*, vol. 13, no. 12, 2020.
- [8] M. Syed *et al.*, "Applicability of geographically distributed simulations," *IEEE Trans. Power Syst.*, vol. 38, no. 4, pp. 1–15, July 2023.
- [9] B. Palmintier, B. Lundstrom, S. Chakraborty, T. Williams, K. Schneider, and D. Chassin, "A power hardware-in-the-loop platform with remote distribution circuit cosimulation," *IEEE Transactions on Industrial Electronics*, vol. 62, no. 4, pp. 2236–2245, 2015.
- [10] S. Vogel *et al.*, "Improvements to the co-simulation interface for geographically distributed real-time simulation," in *IECON 2019*, vol. 1, 2019, pp. 6655–6662.
- [11] Y. Wang *et al.*, "A distributed control scheme of microgrids in energy internet paradigm and its multisite implementation," *IEEE Transactions on Industrial Informatics*, vol. 17, no. 2, pp. 1141–1153, 2021.
- [12] E. Guillo-Sansano, M. H. Syed, A. J. Roscoe, and G. M. Burt, "Initialization and synchronization of power hardware-in-the-loop simulations: A great britain network case study," *Energies*, vol. 11, no. 5, 2018. [Online]. Available: <https://www.mdpi.com/1996-1073/11/5/1087>
- [13] G. Benedetto *et al.*, "Ensiel national energy transition real time lab: a novel tool to shape the future energy system," in *2022 AEIT International Annual Conference (AEIT)*, 2022, pp. 1–6.
- [14] M. Maniatopoulos, D. Lagos, P. Kotsampopoulos, and N. Hatzigiorgiou, "Combined control and power hardware in-the-loop simulation for testing smart grid control algorithms," *IET Generation, Transmission & Distribution*, vol. 11, no. 12, pp. 3009–3018, 2017.
- [15] M. Galici, M. Mureddu, E. Ghiani, and F. Pilo, "Blockchain-based hardware-in-the-loop simulation of a decentralized controller for local energy communities," *Energies*, vol. 15, no. 20, 2022.
- [16] D. Stahleder, D. Reihls, and F. Lehffuss, "Lablink – a novel co-simulation tool for the evaluation of large scale EV penetration focusing on local energy communities," in *CIREN 2018 Ljubljana Workshop*, 2018.
- [17] D. Carta *et al.*, "Villasnode-based co-simulation of local energy communities," in *2022 Open Source Modelling and Simulation of Energy Systems (OSMES)*, 2022.
- [18] E. Bompard *et al.*, "Latency and simulation stability in a remote power hardware-in-the-loop cosimulation testbed," *IEEE Trans. Ind. Applications*, vol. 57, no. 4, pp. 3463–3473, 2021.
- [19] CIGRE, "Benchmark systems for network integration of renewable and distributed energy resources," 2014.
- [20] A. Bonfiglio, M. Invernizzi, A. Labella, and R. Procopio, "Design and implementation of a variable synthetic inertia controller for wind turbine generators," *IEEE Trans. Power Syst.*, vol. 34, no. 1, p. 754–764, 2019.
- [21] R. Salcedo *et al.*, "Banshee distribution network benchmark and prototyping platform for hardware-in-the-loop integration of microgrid and device controllers," *The Journal of Engineering*, vol. 2019, no. 8, pp. 5365–5373, 2019. [Online]. Available: <https://ietresearch.onlinelibrary.wiley.com/doi/abs/10.1049/joe.2018.5174>
- [22] M. H. Syed *et al.*, "Real-time coupling of geographically distributed research infrastructures: Taxonomy, overview, and real-world smart grid applications," *IEEE Trans. Sm. Grid*, vol. 12, no. 2, pp. 1747–60, 2021.
- [23] GEANT, "GEANT membership maps," <https://about.geant.org/membership/membership-map/>, 2023, [Online].
- [24] S. Vogel, "VILLASframework Project Page," <https://www.fein-aachen.org/en/projects/villas-framework/>, 2023, [Online].
- [25] A. Mazza *et al.*, "Internet of laboratories - live demonstration," May 2023. [Online]. Available: <https://doi.org/10.5281/zenodo.7897495>