

Broadband Power Line Communication in Railway Traction Lines: A Survey

Original

Broadband Power Line Communication in Railway Traction Lines: A Survey / Angrisani, L., D'Arco, M., De Benedetto, E., Duraccio, L., Lo Regio, F.. - In: ENERGIES. - ISSN 1996-1073. - ELETTRONICO. - 16:17(2023). [10.3390/en16176387]

Availability:

This version is available at: 11583/2982503 since: 2023-10-02T08:09:21Z

Publisher:

MDPI

Published

DOI:10.3390/en16176387

Terms of use:

This article is made available under terms and conditions as specified in the corresponding bibliographic description in the repository

Publisher copyright

(Article begins on next page)

Review

Broadband Power Line Communication in Railway Traction Lines: A Survey

Leopoldo Angrisani , Mauro D'Arco * , Egidio De Benedetto , Luigi Duraccio  and Fabrizio Lo Regio 

Department of Information Technologies and Electrical Engineering, University of Naples Federico II, Via Claudio 21, 80125 Napoli, Italy; angrisan@unina.it (L.A.); egidio.debenedetto@unina.it (E.D.B.); lu.duraccio@studenti.unina.it (L.D.); fabrizio.loregio@unina.it (F.L.R.)

* Correspondence: darco@unina.it; Tel.: +39-081-7683-237

Abstract: Power line communication (PLC) is a technology that exploits existing electrical transmission and distribution networks as guiding structures for electromagnetic signal propagation. This facilitates low-rate data transmission for signaling and control operations. As the demand in terms of data rate has greatly increased in the last years, the attention paid to broadband PLC (BPLC) has also greatly increased. This concept also extended to railways as broadband traction power line communication (BTPLC), aiming to offer railway operators an alternative data network in areas where other technologies are lacking. However, BTPLC implementation faces challenges due to varying operating scenarios like urban, rural, and galleries. Hence, ensuring coverage and service continuity demands the suitable characterization of the communication channel. In this regard, the scientific literature, which is an indicator of the body of knowledge related to BTPLC systems, is definitely poor if compared to that addressed to BPLC systems installed on the electrical transmission and distribution network. The relative papers dealing with BTPLC systems and focusing on the characterization of the communication channel show some theoretical approaches and, rarely, measurements guidelines and experimental results. In addition, to the best of the author's knowledge, there are no surveys that comprehensively address these aspects. To compensate for this lack of information, a survey of the state of the art concerning BTPLC systems and the measurement methods that assist their installation, assessment, and maintenance is presented. The primary goal is to provide the interested readers with a thorough understanding of the matter and identify the current research gaps, in order to drive future research towards the most significant issues.

Keywords: railway systems; broadband powerline communication; channel modeling; channel characterization; metrological characterization; noise characterization



Citation: Angrisani, L.; D'Arco, M.; De Benedetto, E.; Duraccio, L.; Lo Regio, F. Broadband Power Line Communication in Railway Traction Lines: A Survey. *Energies* **2023**, *16*, 6387. <https://doi.org/10.3390/en16176387>

Academic Editor: Chunhua Liu

Received: 31 July 2023

Revised: 29 August 2023

Accepted: 31 August 2023

Published: 3 September 2023



Copyright: © 2023 by the authors. Licensee MDPI, Basel, Switzerland. This article is an open access article distributed under the terms and conditions of the Creative Commons Attribution (CC BY) license (<https://creativecommons.org/licenses/by/4.0/>).

1. Introduction

The fourth industrial revolution has brought forth a plethora of technological advancements that are enabling and/or improving new paradigms, which seem deemed to transform the lives of individuals [1]. Among these, the Internet of Things (IoT) [2], artificial intelligence (AI) [3], machine and deep learning (ML/DL) [4], cloud computing [5], additive manufacturing [6], and augmented and virtual reality (AR/VR) [7] are the most popular. These paradigms rely on several data communication solutions, which are selected according to their specific advantages to face costs, installation, and time-to-market issues. Unexpectedly, even some unusual proposals have been revitalized, such as the power line communication (PLC) technology [8].

PLC harnesses the inherent potential of the electrical distribution network to facilitate data transmission capabilities. By exploiting the existing infrastructure of the power grid, PLC enables the communication of data signals through the electrical power lines [9], allowing for the simultaneous transfer of electrical power and data for signaling and remote control [10,11].

Similarly to the transmission and distribution network, other infrastructures can be exploited as guiding structures to propagate electromagnetic signals. A relevant example is the electrical railway system, where the catenary and the railway tracks can transmit both the power needed to the traction operations as well as the data.

Actually, the growing focus on safety and maintenance of the railway network, and the increase in services offered on board, raise the demand for robust communication technologies. These should grant high data rates, low latency, and coverage and service continuity to enable high-speed internet connection for service management and entertainment [12,13]. Railway operators are paying attention to broadband power line communication (BPLC) technologies. These exploit the high-frequency range, namely, the HF band of the electromagnetic spectrum, and employ suitable solutions to transmit a relevant amount of data in a reduced time interval [14]. More specifically, railway operators have fostered the concept of broadband traction power line communication (BTPLC), where the electric traction line is exploited as a channel for broadband communications rather than for simple signaling and control operations [15].

A BTPLC system is designed with the aim to establish a communication link between on-board and wayside devices, as illustrated in Figure 1. The link has to cope with the requirements of advanced security systems, predictive maintenance, and other 4.0-driven applications [16].

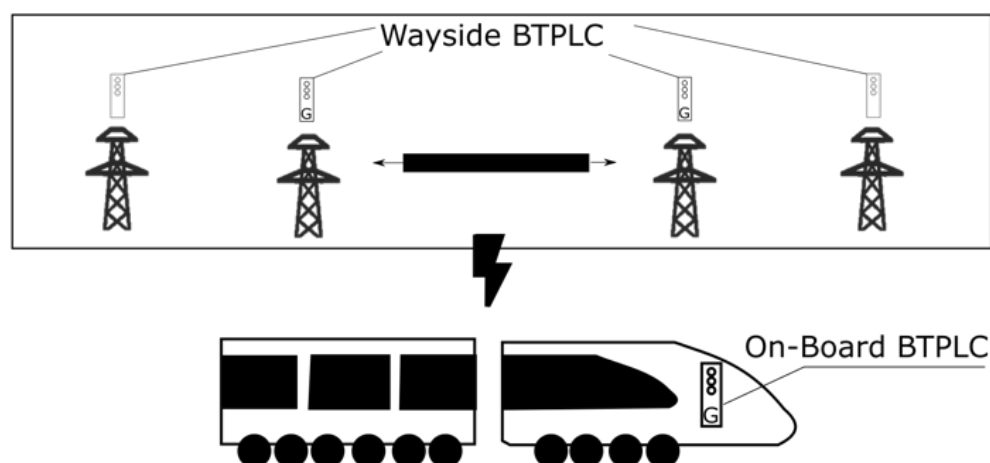

Figure 1. BTPLC system for data communication between on-board and wayside devices.

BTPLC technology should support the transmission of train-related data and other sensor-derived information. These include position, velocity, and vibration parameters, as well as environmental data in terms of weather conditions, and network-specific data, such as the number of interconnected trains. The subsequent data analysis enables the implementation of useful policies to reduce maintenance costs and operations, improve maintenance scheduling, and ensure the proper operation of the network safely [17–19].

It is expected that BTPLC solutions will play a critical role in predictive maintenance, where artificial intelligence-based approaches are becoming widespread. These approaches necessitate of a substantial volume of data related to the condition of the railway network, the train, and its components, and hence of effective solutions for transmission and storing operations [20].

The adoption of BPLC technology in railways is further motivated by the increasing focus on sustainable policies. Rail transport is acknowledged as a better alternative to road transport and a key element in atmospheric emission reduction strategies [21]. Environmental policies, in fact, are driving the transition of the land transportation system from a vehicle-centered model to a rail-centered one [22]. This shift towards the railway system is projected to yield a significant reduction in energy consumption as appealing as the substitution of the fuel engines with the electric ones in automotive [23].

Taking all these factors into account, it becomes evident that BPLC technology is intriguing to railway operators that have to fulfill more and more advanced service delivery. But, utilizing the pre-existing network, originally designed for electrical distribution purposes, poses various technical challenges that need to be addressed when employing it for high-frequency data transmission [24]. Unlike several networks used for low and medium-voltage power distribution, those employed in the railway sector present additional challenges. The main ones are related to the existence of different network topologies, which are difficult to characterize; to the time-varying nature of the system, which impacts the communication channel behavior; and to the numerous sources of noise and interference [25].

Recently, researchers have pointed out the need for effective methodologies to address the design, implementation, and evaluation of broadband communication channels exploiting electric traction lines for signal propagation. In this regard, several contributions have put forth intriguing methodologies. However, to the best of the author's knowledge, a comprehensive overview encompassing both theoretical notes and experimental protocols, to be considered at design, installation, assessment, and maintenance stages, is still absent. In an effort to address this dearth of information, the authors have produced a survey that delineates the current state of BTPLC systems, where special attention is paid to the test and measurement activities needed for installation, evaluation, and maintenance. More specifically, the survey presents the performance metrics and measurement apparatuses adopted to characterize the electric traction lines in the light of installing solutions for broadband power line communications. Its goal is to systematically analyze and evaluate the existing literature in order to provide a comprehensive understanding of the topic and guide future research efforts.

The survey has considered the papers published from 2006, which are closely related to the deployment of BPLC technologies in the railway domain. A search on the Scopus database using the keywords *PLC*, *broadband*, and *railway* yielded a total of 54 papers as of July 2023. From this set, nine papers were carefully selected for a comprehensive and detailed comparison. The selection criteria for these papers primarily emphasized articles published in scientific journals that clearly outlined the operation of the BTPLC system. In particular, each of the chosen papers presented an improved model or methods for characterizing the BTPLC channel.

The survey starts with an overview of the PLC fundamentals, with an emphasis on the taxonomy of the technology in Section 2. Subsequently, Section 3 reviews the literature highlighting the typical architectures adopted in BTPLC systems and the features and parameters of interest related to the communication channel. Then, Section 4 explores the key findings extracted from the literature analysis, distinguishing between top-down and bottom-up approaches, and comments on them. Finally, conclusions are drawn.

2. Background on PLC Technology

PLC is a concept born at the beginning of the 20th century, developed for signaling and control operations [26]. As mentioned in Section 1, it refers to technology that allows for data communication over existing electrical power lines, providing for the simultaneous transfer of electrical power and data. PLC technologies effectively utilize the existing infrastructure, enabling a cost-efficient and streamlined deployment approach. They represent an appealing alternative to those solutions that necessitate the installation of new networks for several reasons. First of all, the use of an already installed cable network allows cost and installation time reductions in the deployment of the communication system [27]. PLC solutions are not affected by the typical problems of systems that exploit the free propagation of the electromagnetic signal, which means they perform better in those scenarios of the rural area or where obstacles limit wireless communications [28]. In fact, wireless setups are generally more delicate and vulnerable than power lines [29]. It is worth highlighting that the aforementioned issues have already paved the way to the implementation of communication channels that are integrated into the existing electrical

transmission and distribution network. These communication channels have shown to be a viable solution for the service providers to afford important managing tasks and meet the stringent service delivery demands. In a believable way, for a wide range of application scenarios, including railways, the PLC technology still has a role to play.

2.1. Taxonomy

PLC technologies can be classified based on the characteristics of the underlying electrical system and/or specific features as described in the following.

Current regime: It is a distinction based on the utilization of the direct current (DC) or alternating current (AC) regime. The first is often preferred due to its simpler structure as the AC regime requires phase and reactive power control; for PLC applications, the installation seems facilitated upon lines operated in the DC regime [30].

Nominal voltage: It is a distinction based on the operating voltage value of the power grid on which the PLC is installed. According to the European norm *EN 50160* [31], power grids can be classified as low-voltage (LV) if the nominal voltage is less than 1 kV, medium voltage (MV) if it is within the range (1–35) kV, and high voltage (HV) if it is above 35 kV. LV and MV power grids are generally used for electricity supply in urban and suburban areas, while HV grids are used for long-distance power transmission.

Frequency range: PLC technologies can be categorized according to the range of operating frequency values of transmitted signals [32]. This feature is indicative of data transmission speed and distance. According to the literature, the frequency range in which PLC systems can operate covers frequencies from 125 Hz to 100 MHz [33–35]. PLC systems are usually referred to as shown in Table 1:

Table 1. PLC systems according to the frequency range.

<i>Ultra-narrowband</i>	Identified by the operating frequency range (125–3000) Hz. Ultra-narrowband PLC (UN-PLC) technology typically guarantees transmission over long distances, although the data rate is typically in the order of kbps [28]. Examples of UN-PLC are the home automation system by Pico Electronics X10 deployed since 1975 [34] and the two-way automatic communication system (TWACS) by Aclara [28].
<i>Narrowband</i>	Identified by the operating frequency range (3–500) kHz. Narrowband PLC (NPLC) technologies are characterized by variable data rates from 1 kbps up to 1 Mbps and are capable of guaranteeing medium/long transmission distances [28]. In Europe, they are distinguished into four frequency bands, standardized by the European Committee for Electrotechnical Standardization (CENELEC) in 1992 [28]: CENELEC-A (3–95 kHz), CENELEC-B (95–125 kHz), CENELEC-C (125–140 kHz), and CENELEC-D (140.0–148.5 kHz). According to the data transmission rate, NPLC systems are also referred to as low data rate (LDR) and high data rate (HDR). LDR systems adopt single-carrier modulations, whereas HDR exploit multi-carrier modulations to achieve data rates up to 1 Mbps [28].
<i>Broadband</i>	Characterized by a data rate above 200 Mbps and shorter transmission distance than NB-PLC [14]. The operating frequency range is not uniformly established: according to the Institute of Electrical and Electronic Engineers (IEEE) [35], it ranges from 1.8 MHz up to 100.0 MHz. The International Telecommunication Union (ITU) instead specifies a frequency range up to 300 MHz [36]; the standards developed by the HomePlug Powerline Alliance use the frequency ranges (1.8–30.0) MHz and (1.8–86.0) MHz [36].

Transmission distance: The distinction is made between short-range PLC systems, with transmission distances of up to 80 km; medium-range systems, spanning between 80 km and 250 km; and long-range systems, designed for transmission distances exceeding 250 km [36].

Indoor/outdoor environment: Indoor PLC refers to the use of power line communication technology within indoor environments such as homes, offices, or industrial buildings. It typically operates within a confined space and utilizes the existing electrical wiring infrastructure to transmit data signals [37]. Outdoor PLC involves the deployment of power line communication technology in outdoor settings, such as urban lighting or surveillance systems, or smart grid applications. Much more than indoor systems, outdoor PLC systems are designed to withstand harsh environmental conditions. These can be due

to large temperature variations, moisture, dust, and potential electrical interference caused by nearby power lines or other outdoor equipment [38].

For clarity, Figure 2 illustrates a schematic representation of the categorization of PLC systems, highlighting the relevant categories in which BTPLC technology falls, as indicated in bold.

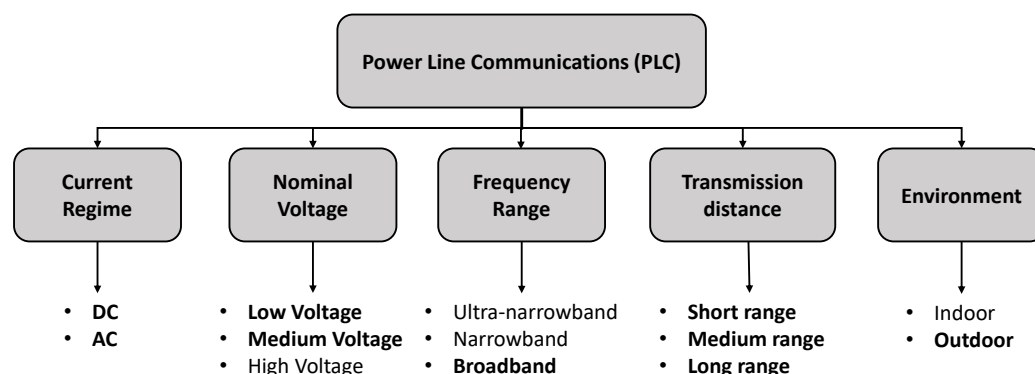

Figure 2. Details of the PLC categorizations: the categories in which BTPLC technology falls are indicated in bold.

2.2. Further Remarks

PLC technology, initially utilized for indoor applications, is experiencing a significant expansion into outdoor settings, particularly in the areas of smart grid applications and railway traction lines. This expansion is evident in the increasing utilization of PLC-based applications for grid monitoring and IoT services. PLC technology has garnered substantial interest and attracted the attention of railway system operators as it offers enhanced capabilities and growth opportunities. Traditionally, railway systems were designed as closed systems with limited interaction and data exchange with other systems to minimize the risk of malfunctions in railway infrastructures. However, PLC technology is serving as the enabling technology for railways to integrate them into the smart city ecosystem [39]. With the growing interest in applications like advanced metering and home automation, the global PLC technology market surpassed \$8 billion in 2021 and is projected to reach \$35 billion by 2030 [40]. This increased investment in PLC technology is also linked to the railway industry, which experienced a 2.6% increase in passenger traffic in rail transport between 2015 and 2019 [41].

3. Body of Knowledge Regarding BTPLC Systems

This section aims to survey the body of knowledge that can be extracted by the scientific literature about BTPLC systems.

3.1. BTPLC Architectures

BTPLC systems are typically composed of six major blocks, as shown in Figure 3.

The first block comprises the power distribution system, which encompasses the traction power substations (TPSS). TPSS nodes form the foundation of the medium voltage (MV) substations, connected to the high-voltage grid. They receive high-voltage electricity from the grid, which is then converted into a suitable form for supplying power to train engines. In direct current (DC) traction systems, power substations consist of transformers and rectifiers, with the latter responsible for converting alternating current (AC) into direct current (DC) [42].

The second block is constituted by the power line, which encompasses the catenary to convey the electric power along the line, facilitating the power supply distribution. Specifically, power is transmitted through the catenary to the train by means of one or a couple of pantographs. In the context of power line communication, the catenary also serves as the medium through which data transmission occurs.

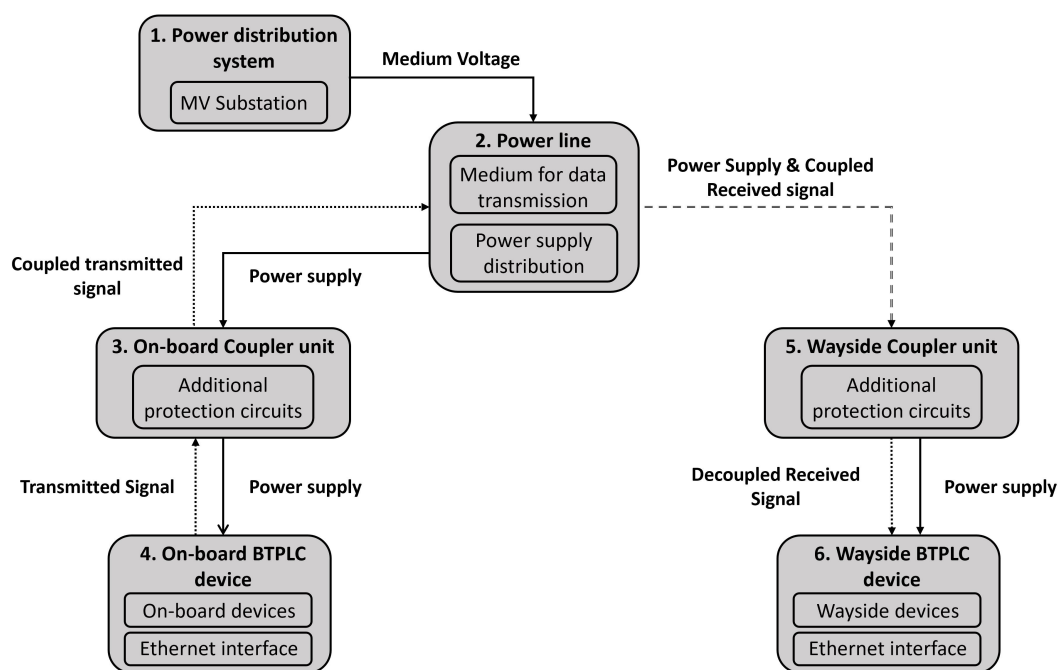

Figure 3. Main blocks of a BTPLC architecture: the solid line represents the power transfer between the blocks, the dashed line indicates both power and data transfer, and the dotted line uniquely stands for data transfer between blocks.

In Europe, the components found in the first and second blocks are common across various railway infrastructures, despite the presence of different electrification systems. It is crucial to differentiate between rail network categories as they give rise to notable disparities in the selection of the devices and techniques employed at the implementation stage. As early as 1933, Garczynski [43] observed that the United States and Europe adopted different methods of line coupling owing to differences in power line voltages and network topologies. In relation to railway lines, they are often classified into four main categories: regional, urban, inter-city, and high-speed. Table 2 presents the main differences among these categories, taking into account the Italian framework as an example. The allocation of a limited number of services for the higher classes, or a single unitary service in the case of urban routes, reflects the current state of affairs. However, with the implementation of BPLC technology, an increase in rail services is likely even for the urban category.

Table 2. Rail networks categories in Italy [12].

Features	Regional	Urban	Inter-City	High-Speed
Maximum speed (km/h)	70	70–160	160–250	>250
Line length (km)	<20	20–100	100–250	>250
Number of provided services	Single	Low	In the middle	Large

The third and fifth blocks pertain to the coupler units employed for on-board and wayside BTPLC devices, respectively. In both cases, the coupler serves as a crucial device situated between the modems and the power line [44]. Its functions include both protection against potential damage and the transmission and reception of the communication signal via the transmission line. Note that the transmitted signals must be superimposed to the waveform of the power supply, whereas the received signals must be separated from the waveform of the power supply: couplers are adopted to this end. Couplers can be classified according to voltage level, DC or AC regime, frequency band, physical connection type (capacitive, inductive, or resistive), mode of propagation (common or differential), or number of connections (single-input–single-output, single-input–multi-output, or or multi-

input–multi-output) [45]. To ensure electrical isolation between the power distribution line and the data line, couplers are typically equipped with an isolation transformer [46]. The transformer also provides impedance matching between the two lines [47]. Impedance mismatch, resulting from the time-frequency varying behavior of the line impedance [48], can in fact significantly degrade transmission power [49]. Coupling devices, acting as high-pass filters, should exhibit a fine frequency response within the PLC transmission band to reject the supply voltage [50]. Capacitive couplers are commonly employed for power line communications [51]. Additional protection circuits may be employed to safeguard the PLC modem against overvoltages. However, attention must be given to their impedance to prevent the creation of low-impedance paths.

The fourth block encompasses BTPLC devices (i.e., modems), which are installed on-board the train or tram. These devices are typically equipped with features like smart sensors and cameras, serving various purposes such as onboard security. On the other hand, the sixth block comprises BTPLC devices placed on the ground or along the power line, which operate as repeaters or control devices. These ground-based devices establish communication with the onboard devices, facilitating ground-vehicle communication. The on-board BTPLC devices need to be installed on every vehicle within the operational fleet. They are responsible for enabling communication within each individual vehicle. In contrast, the wayside BTPLC devices consist of multiple devices that facilitate communication between the ground-based and the on-board devices. This allows for communication between the vehicles and the ground infrastructure. Both the on-board and ground-based devices must support an ethernet interface to access IP-based networks. The onboard devices are integrated into the onboard local area network (LAN), while the ground-based devices are integrated into the ground or distribution networks.

To simplify the description of the architecture, the remote control equipment, including alarm control and management stations for managing network switches, has been excluded from the representation. Also, the bidirectionality shared by all the blocks (except the first) has not been explicitly depicted. It is important to note that in a two-way communication setup, the onboard devices receive data transmitted by other onboard BTPLC devices on different vehicles within the fleet, as well as by wayside BTPLC devices.

In BTPLC systems, one can distinguish between (i) train-to-infrastructure, (ii) train-to-train, and (iii) infrastructure-to-infrastructure communication links. For all the three links, the communication can be bidirectional, but the performance requirements can vary depending on the type of communication and the specific application. Furthermore, the choice of the most suitable BPLC apparatuses for specific applications depends on the transmission channel of the network where the BPLC technology is deployed. Characterizing the channel is therefore essential in order to design the PLC system, facilitate its deployment, and ensure optimal performance [52]. According to the existing literature, the characterization of the communication channel is typically conducted by focusing on the major aspects indicated in Figure 4, which are described in detail in the following subsections.

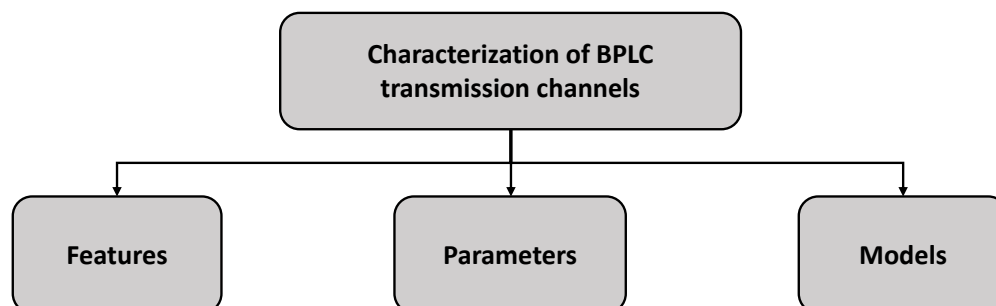

Figure 4. Major aspects regarding the characterization of BPLC transmission channels.

3.2. BTPLC Features

The typical BTPLC features, regarding grid topology, noise and emissions, and frequency selectivity are listed as follows.

3.2.1. Grid Topology

The first feature of interest is the power grid topology, which refers to the arrangement and configuration of the electrical power distribution network. It plays a crucial role in determining how PLC operates and performs in a given area. The grid structure differs from country to country and even within countries, making the standardization of the PLC transmission channel complex. Additionally, the multipath nature of the grid is another crucial aspect as the signal can be split between useful and parasitic paths and can undergo abrupt power reductions. [53]. Moreover, short-time changes in the grid structure encompass alterations in the properties of the propagating medium, resulting from load insertion and detachment. This phenomenon is caused by reflections of the transmitted signal along the transmission line. This phenomenon is also contingent upon the interplay between the wavelengths of the data signal and the physical length of the line, as well as the impedance mismatch between the line and the connected devices.

Since BTPLC systems fall under the outdoor PLC category, the transmission channel is subject to phenomena that complicate its characterization compared to indoor channels [54]. Among them, there are the state of the train, taking into account factors such as its speed and acceleration, and the impact of weather conditions on the traction line.

The lack of changes in grid topology, a condition deemed realistic for short durations and controlled circumstances, does not ensure the time-invariance of the transmission channel. This is because the characteristics of the devices connected to the grid are contingent upon the instantaneous amplitude of the supply voltage, which can fluctuate due to periodic variations in the load impedance. Then, the time-varying channel can be considered cyclostationary, subject to short-term cyclic variations [55].

Regarding the state of the art, there have been few measurement campaigns conducted to represent time-varying effects accurately. The scarcity of information regarding the characterization of the transmission channel for outdoor grids is primarily attributed to the costs associated with conducting experimental activities for BPLC systems of this nature. These costs stem from the requirement for a specialized electrical team and its mobilization, the need for a variety of instruments, and auxiliary devices to grant operation safety. Nonetheless, a measurement campaign requires the complete control of the railway path and rolling stocks, which during the most of the experimental activities are set temporarily unavailable to the public [56].

3.2.2. Noise and Emissions

Noise and emissions can be considered challenges of BTPLC as they have a significant impact on the performance and regulatory compliance of PLC systems. BPLC systems are subject to regulations that prescribe permissible limits for electromagnetic radiation [57], in order to address the adverse impacts they have on PLC communication. Noise and non-intentional emissions (NIE) in BPLC systems [58,59] are primarily attributed to the utilization of the power-line communication (PLC) grid as a high-frequency data transmission channel [60]. In the far field, the emissions undergo mutual cancellation owing to the inherent symmetry present in the system [61]; this symmetry generally stands because of the power balance maintained across each phase of the transmission power system (TPS). But, this balance can occasionally be disrupted for uneven power consumption among locomotives connected to each catenary [62,63], or unpredictable meteorological events. This is an issue for the railway system as well, which is contrasted by means of rail power conditioners (RPCs) [64] or power electronics converter [65], which help in restoring the equilibrium and mitigating any associated problems.

The noise from which devices and more generally the BTPLC environment are affected is a function of different parameters that define its origin, amplitude, and representation. NIEs are composed of different contributions [66–69], which are enlisted in Table 3:

Table 3. Contributions to NIEs.

<i>Background noise</i>	Known as continuous time-invariant noise, it is noise with a mean square value of constant amplitude in time windows of fixed duration. In the context of an AC power grid, these time windows extend beyond the duration of the voltage cycle. It primarily manifests in the high-frequency range (beyond 10 MHz) [66], with a greater power concentration at lower frequencies, below 1 MHz [24,66].
<i>Continuous time-varying noise</i>	It is noise with synchronous variations with respect to the mains supply voltage, with a period that corresponds to half the period of the voltage in the case of an AC supply network.
<i>Impulsive noise</i>	It is characterized by high amplitude and short time duration, typically on the order of μs – ms . It is the predominant nature of the noise in a BTPLC channel operating under a DC current regime [67]. Impulsive noise was classified into synchronous periodic, asynchronous periodic and isolated, with primary causes respectively attributed to rectifiers, switched-mode power supplies, and the insertion and disconnection of devices from the power distribution network.
<i>Narrowband noise</i>	It originates from wireless communication systems [68] with components in the frequency interval (1–88) MHz.
<i>Crosstalk</i>	This noise is generated in a transmission cable as a result of conductive, capacitive, or inductive coupling effects, caused by the proximity of a signal-carrying cable [69].

The levels of noise and NIEs are known for the frequency interval (2–150) kHz, while they, as well as the disturbance they may cause in communication systems, are not known for operating frequencies above 1 MHz. Also, for conductive and radiated emissions, there is a lack of standards in outdoor applications [70,71].

To enhance the robustness of communication and mitigate the detrimental effects of NIEs and noise on data transmission quality, coding and modulation techniques are commonly employed. Among these techniques, orthogonal frequency division multiplexing (OFDM) is widely recognized and extensively studied in the literature. It is a modulation scheme that partitions the transmitted data into blocks and transfers them simultaneously over parallel independent sub-carriers [72]. Since OFDM simultaneously transmits symbols on each sub-carrier, the effects of impulsive noise are spread out over multiple symbols [72] so that the overall data are not affected by the noise [73].

3.2.3. Frequency Selectivity

The channel frequency selectivity plays a critical role in determining both the amplitude distortion and delay. The frequency response of the PLC channel, typically expressed in the frequency domain by $H(f)$, can exhibit notable variations in channel characteristics. In recent years, the frequency response has also been suggested as a means to estimate the impedance [74]. In the context of linear time-invariant systems, the frequency response $H(f)$ is defined as the ratio of the output voltage to the input voltage of the channel.

3.3. BTPLC Parameters

The typical BTPLC parameters, regarding signal attenuation, line impedance, and frequency response, are listed as follows.

3.3.1. Signal Attenuation

One of the primary challenges for PLC systems is facing signal attenuation along the channel. Signal attenuation refers to the decrease in power level between the signal generated by the transmitting device and the signal received by the receiving device. This attenuation is primarily caused by energy absorption in the transmitting medium, signal reflections resulting from impedance mismatches, dispersion along the line into other devices, and the branching of the guiding structure into different paths [75]. The loss in transmission, denoted as L_t , can be expressed in dB as shown in Equation (1), where P_0

represents the signal power received at the receiving device and P_i represents the signal power transmitted by the transmitting device.

$$L_t = 10 \log_{10}\left(\frac{P_0}{P_i}\right) \quad (1)$$

Several factors contribute to the attenuation of the signal in addition to the topology. These factors include: the type of cables, ancillary devices acting as loads, including couplers, the frequency range chosen for the modulated data, the line length in different sections, and the overall line length [76]. As expected, signal attenuation is directly proportional to both distance and frequency [77]. Tonello et al. [78] demonstrated that attenuation significantly increases with higher frequencies, reaching values exceeding 50 dB/km for frequencies greater than 1 MHz. These substantial power losses cannot be compensated for by increasing the transmitted signal power. In fact, electromagnetic compatibility issues put restrictions on the transmitted signal power; nonetheless, there are physical limitations of the devices in the network that put an inherent limit to the output power. The skin effect, as described by [79], also results in signal attenuation along the PLC line, which increases upon the square root of the frequency. The outdoor PLC environment exhibits higher attenuation and less variation than the indoor environment. Moreover, Kiedrowski et al. [80] found that the primary contributor to attenuation is the mismatch between the modem and the line, rather than the cable length. This mismatch is due to the difference between the values of the impedance of the modem and input impedance $Z_i(f)$, i.e., the impedance seen by the transmitter. It is related to the line impedance value Z_0 , which is defined as the load seen by the transmitter. Since it is related to the amount of reflected power, its value directly impacts the design of the analog front-end component of the PLC modem.

3.3.2. Input Impedance

The input impedance can be obtained as [81]:

$$Z_i(f) = Z_0 \frac{1 + s_{11}(f)}{1 - s_{11}(f)} \quad (2)$$

where Z_0 is the line impedance and s_{11} the reflection coefficient of the input port. The coefficient s_{11} is one of the four scattering parameters s_{ij} ($i, j = 1, 2$), generally used to describe the behavior of a system or device or verify the impedance matching quality. These parameters are arranged into a scattering matrix, which describes the correlation between the incident and reflected power at the input and output ports. Apart from the reflection coefficient of the input port s_{11} , the other parameters are the reflection coefficient of the output port s_{22} , the forward gain s_{21} , and the reverse gain s_{12} . In general, the line impedance is characterized by both time and frequency variations [82]. In addition, due to resonant effects, impedance values can greatly vary even within a narrow frequency range [83]. These effects are responsible for impedance mismatches. Due to this, real-time impedance estimation can be used to improve the impedance matching with the line. Despite this variation over time and frequency, with lower values for low frequencies and higher values for higher frequencies, it is assumed that the frequency-dependent variation is smaller in broadband systems [84]. This simplifies the choice of impedance-matching techniques for BTPLC technologies, which are made necessary to avoid reflection phenomena.

3.3.3. Frequency Response

Further metrics of interest, derived from the frequency response, are explained in [85–91] and briefly summarized in Table 4.

Table 4. Metrics derived from the frequency response of the channel.

<i>Impulse response duration</i>	This refers to the time duration that encompasses a specified percentage of the total energy contained in the impulse response [42].
<i>Average channel gain</i>	This denotes the channel gain averaged over the band of interest. It is expressed as $G_c = 10 \log_{10}(\frac{1}{N} \sum_{i=0}^{N-1} H_i ^2)$, where H_i denotes the i -th sample of the channel frequency response [85], typically measured on a discrete grid of uniformly spaced points. A related metric is the average channel attenuation $A_c = -G_c$ [86].
<i>Average delay</i>	This is a measure of the mean delay of signals, and it is represented by the first-order moment of the delay power spectrum. Its typical value is in the range (160 ns–4.2 μ s) [87]
<i>Root mean square delay spread (RMS-DS)</i>	This is defined as the square root of the second-order central moment of the power delay profile and represents the distribution of transmitted power in the time domain over the different paths in the PLC network [88]. The RMS-DS can be considered as a measure of the time dispersion, due to the reflections at the joint of different branches with impedance mismatch [89]. The sampling period is denoted by $T_s = 1/f_s$, and the RMS-DS metric is expressed by $\sigma_\tau = \sqrt{\mu'_0 - \mu_0^2} = T_s \sigma_0$, where σ_0 is the RMS-DS normalized for unit sampling time, μ_0 the is average delay normalized for the unit sampling time, and μ'_0 is its second-order central moment. Its typical value is less than 0.5 μ s [87].
<i>Channel capacity</i>	This represents the maximum amount of information in bytes that can be reliably transmitted along the channel in a given period of time, expressed in seconds, and in a given frequency interval (f_1, f_2) . It is denoted in bps, namely, $C = \max_{P_t(f)} \int_{f_1}^{f_2} \log_2 \left(1 + \frac{ H(f) ^2 P_t(f)}{P_n(f)} \right) df$, where $P_t(f)$ and $P_n(f)$ are the power spectral density (PSD) of the transmitted signal and of the noise, respectively [90]; in the given scenario, the noise is assumed to be background Gaussian noise.
<i>Coherence bandwidth</i>	By considering the bandwidths of the transmitted signal, this metric provides crucial insights into the necessity of employing channel protection techniques due to the dispersive effects caused by multipath propagation [88]. Its definition includes the frequency correlation function, $R(\Delta f) = \int_{B_1}^{B_2} H(f) H^*(f + \Delta f) df$, which is a measure of the correlation between the channel response at different frequencies, spaced by a frequency shift Δf . It is assumed that $H(f) = 0$ outside the frequency range (B_1, B_2) . Hence, the coherence bandwidth represents a statistical measure that provides the range of frequencies over which $R(\Delta f)$ is constant.

3.4. Btplc Models

Several approaches are commonly employed in order to model the transfer function and capture its cyclical variations over short periods of time, both in the time and frequency domains. The time domain approaches are typically associated with statistical tools, like the top-down models, which involve averaging various measurements. On the other hand, frequency domain methods are linked to deterministic tools, like the bottom-up approaches. Moreover, building upon these two approaches, hybrid methods have also been employed in the literature [92,93].

Bottom-up models provide a more accurate representation of the physical propagation of PLC signals within a specific network, whereas top-down models offer the advantage of lower complexity. Deterministic bottom-up approaches allow for an a-priori estimation of the PLC network transfer function, reducing the need for extensive measurement activities for verification purposes. Instead, statistical top-down approaches express the transfer function in terms of multiple paths, obtained through measurement campaigns, and do not require knowledge of the network.

In the railway industry, the complexity of the network, its dynamic variations over time, and the high costs associated with conducting experimental campaigns put challenges for (i) incorporating different network paths into top-down models and (ii) acquiring detailed knowledge of the grid topology for bottom-up models.

The main characteristics of top-down, bottom-up, and hybrid models are deepened in the following paragraphs.

3.4.1. Top-down Models

Top-down models represent the first models developed for characterizing the PLC channel, taking into account the significant effects caused by network branches. These effects include the multipath nature of the line resulting from discontinuities and/or impedance mismatches. Statistical models are constructed by analyzing the outcomes of experimental campaigns or by statistically describing the topology of the grid. In recent years, measurement campaigns have been carried out in broadband outdoor networks [94].

One of the first top-down multipath propagation models was proposed by Zimmermann et al. [53], who proposed the transfer function model described by (3):

$$H(f) = \sum_{i=1}^N |g_i(f)| e^{\phi_{g_i}(f)} e^{-(a_0+a_1f^k)d_i} e^{-j2\pi f \tau_i} \quad (3)$$

in which, for the i_{th} line segment on N , the term $H(f) = |g_i| e^{\phi_{g_i}(f)}$ encapsulates the transmission and reflection factors along the line; $e^{-(a_0+a_1f^k)d_i}$ describes the attenuation, with a_0 , a_1 , and k constant parameters that depend on the characteristics of the line section under consideration; and, finally, $e^{-j2\pi f \tau_i}$ describes the delay in signal transmission. The model described by (3) has been extended by Tonello et al. in [95] as:

$$H(f) = A \sum_{i=1}^N (g_i + c_i f^{K_2}) e^{\phi_{g_i}(f)} e^{-(a_0+a_1f^k)d_i} e^{-j2\pi f \tau_i} \quad (4)$$

where a constant coefficient A is added for the corrections of attenuation, and the term $g_i(f)$ is approximated as a real-valued coefficient with an explicit frequency dependence through the constants K_2 , which is constant and equal for all paths; g_i and c_i depend on the path and are modeled as random variables.

In [91], channel measurements in the time domain were made by using a signal generator, connected to the transmitting port, and a digital oscilloscope, connected to the receiving port to acquire the signal applied by the generator to the line.

Overall, top-down models, as shown in (3), do not necessitate prior knowledge of the PLC grid topology, which can be challenging to obtain. However, they are unable to explicitly incorporate phenomena such as resonance caused by parasitic capacitances or cable characteristics present in the network. Although these models allow for the inclusion of attenuation and delay parameters, determining these parameters can be complex and expensive. This is because one has to consider the possible network configurations, which can undergo significant changes with the addition or modification of even a single network path. In real-world PLC network studies, there is typically limited knowledge regarding the various potential paths within the network.

3.4.2. Bottom-up Models

Bottom-up models rely on deterministic models that necessitate comprehensive knowledge of the grid topology and cable patterns. They make use of transmission line theory to derive models that accurately depict signal propagation along the power line.

The first bottom-up models for BPLC networks were defined by Barnes et al. in [96], Mang et al. in [97], and Galli et al. in [98]. The simplest way to model the frequency response of the channel, according to such deterministic models, is through amplitude and phase voltages that follow a log-normal distribution and a uniform distribution, respectively [99]. Considering these signals, the PLC channel can then be modeled using the ratio of the voltage measured at the receiving port $V_r(f)$ to the voltage $V_i(f)$ measured at the input port of a branch, and considering the product of this ratio for each branch, appropriately multiplied by a coefficient $A(f)$ describing the factor of change in signal attenuation due to the cables. The transfer function varies for each network as a function of topology,

cable length, number of branches, and the probability that each branch is connected to the network. The channel transfer function defined by Tonello et al. in [100,101] is:

$$H_p(f) = A(f) \prod_{i=1}^N \frac{V_r(f)}{V_i(f)} \tag{5}$$

These bottom-up approaches for modeling the PLC channel are discussed in the literature for both indoor [102] and outdoor applications [103]. They involve an approximation of the PLC grid segments by considering the PLC channel as a loaded transmission line using a relationship between input and output voltages and currents to the grid. This approximation can be made via the transmission matrix T , as shown in (6), where subscript 1 denotes the input parameters and subscript 2 denotes the receiving parameters.

$$\begin{bmatrix} V_1 \\ I_1 \end{bmatrix} = T \begin{bmatrix} V_2 \\ I_2 \end{bmatrix} = \begin{bmatrix} A & B \\ C & D \end{bmatrix} \begin{bmatrix} V_2 \\ I_2 \end{bmatrix} \tag{6}$$

This characterization allows one to obtain the transfer function as in (7), where Z_S and Z_L are the network input impedance and load impedance, respectively.

$$H = 20 \log_{10} \left(\frac{Z_L}{AZ_L + B + CZ_L Z_S + DZ_S} \right) \tag{7}$$

The coefficients of the transmission line can be evaluated as follows:

$$\begin{aligned} A &= D = \cosh(\gamma l) \\ B &= Z_0 \sinh(\gamma l) \\ C &= Z_0^{-1} \sinh(\gamma l) \end{aligned} \tag{8}$$

where the parameters l , γ , and Z_0 are the length, propagation constant, and characteristic impedance of the cable, respectively. With regards to more complex transmission lines, the transfer function can be evaluated by (6) but using different $ABCD$ parameters. As an example, Esmalian et al. studied, in [104], the transfer function of a transmission line with one bridge tap. Overall, the transfer function of a generic PLC system, composed of different n branches, can be computed by evaluating the n transmission matrices T_i for $i = 1, \dots, n$ and then the overall transmission matrix as $T = T_1 T_2 \dots T_n$ [105]. A graphical description of the transmission line represented as a 2-port network is provided in Figure 5.

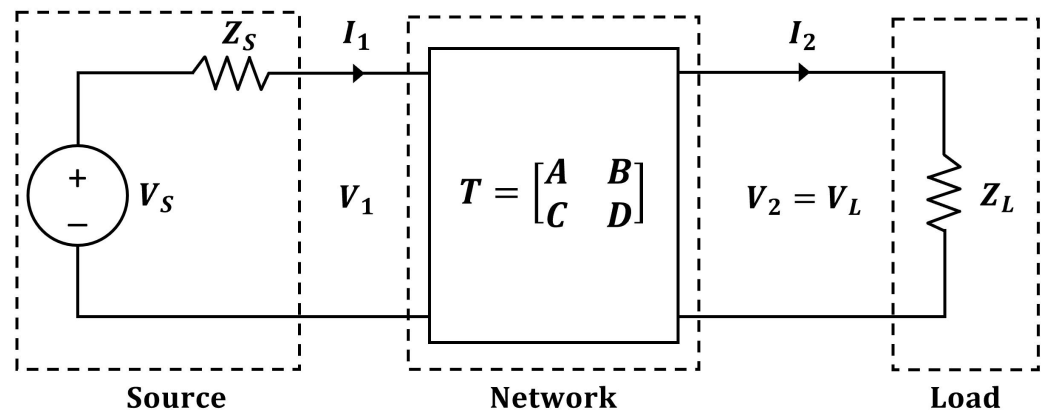

Figure 5. Representation of a 2-port network, along with the transmission matrix $T = ABCD$.

In addition to the aforementioned approaches, there are other state-of-the-art methods proposed for modeling outdoor PLC networks, like scattering parameters matrix-based approaches [106]. For a given line, the outgoing ($\underline{B}_1, \underline{A}_2$) and incoming waves vectors ($\underline{A}_1, \underline{B}_2$) are linked through the scattering parameters matrix \underline{S} according to (9). For the

sake of simplicity, the frequency dependency of all the variables involved in (9) has not been reported explicitly.

$$\begin{bmatrix} \underline{B}_1 \\ \underline{A}_2 \end{bmatrix} = \begin{bmatrix} \underline{S}_{11} & \underline{S}_{12} \\ \underline{S}_{21} & \underline{S}_{22} \end{bmatrix} \begin{bmatrix} \underline{A}_1 \\ \underline{B}_2 \end{bmatrix} \quad (9)$$

The scattering matrix can be obtained by direct measurements or by a numerical model of the two port-device. Issa et al. [107] used the numerical model and the scattering matrix to develop a simulator, later validated by experimental data acquired by measurements that were carried out on outdoor LV PLC networks in Swiss and French. They found that the simulated results are in reasonable agreement with the experimental results but with a discrepancy due to impedance mismatch and radiation losses. The main advantage of this model is in the independence of the matrix from the load change: when the load changes, matrices do not have to be re-evaluated. In some cases, instead of the scattering matrix \underline{S} , the scattering transfer matrix T_W , which is obtained by \underline{S} , is used. It allows for the calculation of the scattering transfer matrix of the overall PLC system, obtained as a product of the individual matrices T_{Wi} of each branch.

Bottom-up models have computational complexity independent of grid topology as they aggregate the effects of discontinuities and multipath into synthetic parameters. However, the major disadvantage of these models is that the grid topology and the type of cables and their parameters need to be accurately known in order to obtain a model as reported in (7).

3.4.3. Hybrid Models

To overcome the limitations and leverage the advantages of both top-down and bottom-up models, different proposals combine them into hybrid models. This hybrid approach utilizes a set of representative topologies that are common in most PLC grids to derive a transfer function. Esmailian et al. [104] made one of the initial attempts to define a model for generating PLC network topologies. They employed a statistical representation of the topology within the bottom-up model, incorporating constraints on the number of branches, distances between nodes, and other characteristic parameters of the network. This model was later extended to account for the cyclostationary nature of the channel [108] and characterized for the European region [109]. Barmada et al. [52] proposed the use of the scattering transfer parameters matrix to obtain an equivalent matrix through the cascade connection of multiple circuits. By multiplying the respective matrices, this method allows for the estimation of the uncertainty of the parameters of each sub-circuit through a variational approach. Consequently, the bounds of the response, influenced by the parameters uncertainty, can be determined through a Monte Carlo procedure involving multiple simulations with random variations of the loads. This method combines aspects of both the top-down and bottom-up approaches as it can be used whether the topology is known or unknown, but it requires measurements of the scattering parameters.

For the sake of comprehensiveness, Table 5 summarizes the three mentioned modeling approaches.

Table 5. Summary of the modeling strategies.

<i>Top-down</i>	Based on statistical models built to analyze the outcomes of the conducted experimental campaigns.
<i>Bottom-up</i>	Based on deterministic models that necessitate complete knowledge of the grid topology and cable patterns.
<i>Hybrid</i>	Based on the combination between top-down and bottom-up modeling strategies. It employs a set of representative topologies to derive the transfer function of the communication channel.

4. Literature Analysis and Discussion

Based on the literature from which the body of knowledge given in the previous Section has been extracted, the key contributions and advancements in the specific field of BTPLC are discussed here.

The specific time frame considered for this review was from 2006 onward, while the inclusion criteria for the considered papers centered primarily around articles written in English and published in scientific journals that provided a clear indication of the essential functional components of BTPLC. This methodology allowed for the selection of nine papers that put forth improved models or methods to characterize the BTPLC channel. Furthermore, the architectures shown in these papers align with the functional blocks defined in Figure 3.

With regard to the frequency response characterization of the PLC line, 6 studies out of 9 employed bottom-up approaches, as shown in Table 6; the remaining three studies employed top-down approaches. To the knowledge of the authors, no relevant study had adopted hybrid approaches as of July 2023.

Table 6. Details of the works considered for discussion in terms of frequency response approach, frequency range, and application scenario.

Work	Year	Approach	Freq. Range (MHz)	Application Scenario
Tang et al. [110]	2006	Top-down	4.5–21.0	Railway simulation and characterization
Barmada et al. [111]	2008	Bottom-up	0–30	UIC cables modeling
Barmada et al. [112]	2009	Bottom-up	0–30	UIC cables modeling
Tang et al. [113]	2011	Top-down	4.3–20.9	Railway simulation and characterization
Francis et al. [114]	2011	Bottom-up	0–100.0	Channel capacity evaluation
Barmada et al. [115]	2016	Bottom-up	0–30	UIC cables modeling
Barmada et al. [77]	2019	Bottom-up	0–30	UIC cables modeling
Belhassen et al. [25]	2020	Top-down	0–35	Railway to wayside communication
Gheth et al. [15]	2020	Bottom-up	10–30	Train speed influence in data transmission

The frequency interval most used in all the considered works is included in the frequency range suggested by the standard HomePlug AV (1.8–30.0 MHz). In addition, 6 works out of 9 (reported in Table 6) expanded their study also in the narrowband and ultra-narrowband ranges.

Only in [114] was a frequency range up to 100 MHz considered: this may be due to the intent of the study of analyzing the channel capacity, expressed in bits/s, over frequency and showing its trend tending to zero, approximately at 100 MHz.

4.1. Top-down Approaches

According to the top-down approaches, Tang et al., in [110], established an electrical railway model made up of a locomotive model on a railroad, and a BPLC system. The model was developed on the track-powered module by using graphite brushes with springs to simulate the pantograph. Communication, in the frequency range of 4.5–21.0 MHz, was provided between two laptops on the PLC channel. One laptop was placed on the locomotive as a mobile device and the other one on the ground as a network service. Laptops were endowed with adapters. Different scenarios in which the communication between the laptop was once from the train to the ground, and then vice-versa for different speeds of the locomotive in the range 25–70 cm/s, were investigated. The success rate of the transmission was independent of the locomotive speed. Also, there was no significant difference between the different flows of communication, from ground to train and vice versa. However, the short speed interval was considered insufficient to generalize the results to a real environment.

For this reason, in [113] the previous railway model was updated with different graphite brushes, motors, and structures of the system in order to guarantee the simulation of a high-speed train, with a speed up to 209 km/h, for a BTPLC system in 4.3–20.9 MHz. There was a discrepancy between the two scenarios of communication flow (from ground to train and vice versa), with a significant difference in success rate, which was better in the scenario from ground to train. However, in both scenarios, the success data rate decreased over train speed, and the highest data rate was equal to 14 Mbps.

Belhassen et al. [25] developed a top-down approach in order to investigate the use of the BTPLC in a tramway train-to-infrastructure context with the aim of developing a BTPLC-based Closed Circuit TV (CCTV), working in the frequency range 4.0–34.0 MHz. The authors carried out the experimental campaigns within a public transport network in Lyon (France), an LV-DC distribution system, on a 15-km line. The developed infrastructure consisted of one onboard PLC system, a static PLC system, and different modems with one or two capacitive couplers on the PLC network, spaced at 350 m each other. The EMC measurements showed no EMC interference between the PLC and railway signals as these signals operate on separate frequency bands without overlapping, while the NIEs showed a higher average value for running trams than for stationary trams, with -40 dB (1 mW) level for frequencies less than 24.0 MHz, and a peak at 13.6 MHz. The line impedance measurements showed a strong variation of the input impedance of the line seen from the coupler to which the PLC modems were connected. According to the signal-to-noise ratio (SNR) measurements, the average value of SNR increases over the frequency, with a downward peak at 22.0 MHz due to the EMC values. Therefore, the operative band was selected in the range 10.0–20.0 MHz. Due to the unstable link between transmitter and receiver with the movement of the tram, the authors created an adaptive system with an extra on-board PLC modem, a switch, and a device for the available link research. In this way, the system managed to automatically detect the PLC modems around the tramway and could compare the bit rate of the available links in order to establish the most stable and fast link. With such a system, the channel capacity increased to 80 Mb/s with a typical latency up to 62 ms.

4.2. Bottom-up Approaches

Barmada et al., in [111], explored the possibility of using single and 16-conductor cables as a BTPLC channel; specifically, the considered cable were UIC onboard cables [116]. They used the two-port model in order to model the frequency transfer function of the line composed by a series of two 20-m lines, the last closed on a $50\ \Omega$ resistance, and the relative FEM model in order to obtain the per-unit-length parameters of the UIC cable. Then, they used the time-domain Wavelet expansion [117] for obtaining the simulation of the frequency response in the range (0–30) MHz by means of the evaluation of the impulse response. The simulations indicated similar responses for the two cables and thus the possibility to use them in an equivalent manner. In addition, they observed an increasing attenuation over frequency in the range of interest. The work was further extended in [112] by comparing the previous simulated per-unit-length parameters of the UIC cables with those obtained by measurements carried out on a 6-m UIC cable provided by Trenitalia S.p.A.. The study again considered the frequency range (0–30) MHz and showed a relative error below 10%. In addition, a series of six 20-m cables with connections of 5 m between them, all terminating with an open circuit, as in [111], or with a $50\ \Omega$ resistance was simulated. Both cases showed a high-quality channel for BTPLC in the range (2–30) MHz, without a significant influence of the $50\ \Omega$ resistance as end load. The cross-talk was evaluated by considering the effects of the data signal in a conductor on the others of the same cable: according to the obtained results, the cross-talk showed negligible effects.

Instead, in [115], the frequency response was simulated for a different number of cables, from one to seven, in the frequency range (2–30) MHz, by observing an increasing attenuation over distance and frequency. By considering a maximum attenuation of -30 dB for practical uses, the need for a repeater every 75 m was highlighted. By evaluating the channel capacity (see Table 4) using trapezoidal interpolation and considering the channel affected by additive white Gaussian noise, a channel capacity value of 80 Mbit/s for a 20 dB SNR was obtained. As is well known, shorter distances are more adequate for high-speed transmissions in the considered frequency range.

The same research group, in [77], evaluated the delay spread, the cumulative distribution function of the frequency response attenuations, and the bit error rate over distance. Transmission power of 55 dBm/Hz over the entire frequency band was considered as it

is typical for PLC devices, and a capacity of 1.6 Mbit/s was obtained. Values of RMS-DS (see Table 4—RMS), which ranged from 52.1 ns for 25 m lines to 411 ns for 175 m lines, in accordance with the literature, were reported [88]. The bit error rate increases over the distance and decreases over the SNR, ranging from 0% for a transmission with 60-dB SNR on a 25 m line to 0.4% for a transmission with 25 dB on a 175 m line.

Francis et al., in [114], used the bottom-up approach with the two-port model in order to model the overhead power line referring to the Indian railways, which uses single-phase double lines in copper or aluminum. These operate with a 50 Hz supply power, provided by substations distant from each other about 32–64 km, which is collected by pantographs and converted to DC. In order to obtain the channel frequency response as in (7), they evaluated the transmission matrix as in (6) for a 100 m line composed of two cables from 0.125 to 0.750 m apart, with per-unit-length parameters ranging in different intervals for copper and aluminum, according to power cable standards. With simulations in the frequency range (0–10) MHz, attenuation at high frequencies, gain increments upon diameters, and channel capacity increments at low frequencies with a maximum of 10 Mbps at approximately 1.5 MHz are shown. Finally, the capacity decreased over distance for all frequencies in the range of interest.

Gheth et al., in [15], proposed a simplified system of the overhead power line for the two-port network model in order to represent its frequency response. The simulation considered the length variation of the transmission line according to the train movement. The length of the line, a characteristic of the $ABCD$ matrix (6), is updated in the simulation according to the train speed and acceleration in a time period, according to the law of uniformly accelerated motion. For a 25 km railway section, the frequency response is evaluated as in (7) within the frequency range (1–30) MHz for different train speeds. It is shown that the amplitude of $H(f)$ decreased over line length and frequency with attenuation increasing over train speed, traveling time, and frequency. For a small distance, i.e., when the train is close to the substation, the attenuation variation over frequency was negligible.

4.3. Overall Considerations

In summary, the selected works primarily investigated the relationship between frequency response, attenuation, and their dependence on frequency and distance. Each work aimed to assess how these factors can influence the performance of the system. Each scenario examined in the works was unique; consequently, the achieved channel capacity varied, ranging from 1.6 Mbps up to 80 Mbps.

5. Conclusions

The survey has considered broadband power line communications for railway traction lines (BTPLC). The reader interested in the field has been provided with useful information related to the theoretical and empirical approaches that have been experimented with to characterize the transmission channel. Specifically, thanks to a thorough analysis of pivotal works published since 2006, the relevant challenges related to the implementation of BTPLC have been highlighted, and the progress made in the field has been figured out. It has been shown that the employed strategies essentially match two approaches, named top-down and bottom-up. The top-down approach, despite its theoretical robustness, is less prolific due to resource-intensive demands. In contrast, the bottom-up one gains more prominence, particularly in the context of channel modeling and simulation across various operational scenarios. The study has then underlined the unbalanced attention paid in the scientific literature to these approaches. Also, an intriguing void in the state of the art has been demonstrated, which involves the absence of hybrid approaches merging the strengths of both top-down and bottom-up approaches; the scientific literature presents some modeling attempts. This research gap offers an opportunity for researchers to contribute to a better understanding of BTPLC systems, with innovative proposals aimed at improving the possibilities of the essential characterization approaches.

Author Contributions: Conceptualization, L.A., M.D., E.D.B., L.D. and F.L.R.; methodology, L.D. and F.L.R.; validation, M.D. and E.D.B.; investigation, M.D., L.D. and F.L.R.; resources, L.A.; data curation, L.D. and F.L.R.; writing original draft preparation, L.D. and F.L.R.; writing review and editing, M.D.; visualization, E.D.B.; supervision, L.A. and M.D.; project administration, M.D.; and funding acquisition, L.A. All authors have read and agreed to the published version of the manuscript.

Funding: The work made by F.L.R. was financially supported by the Italian Ministry of University and Research (MUR) through the project “RESearch and innovation on future Telecommunications systems and networks—RESTART” (D.D. MUR no. 341, 15 March 2022) (CUP E63C22002040007).

Data Availability Statement: Not applicable.

Acknowledgments: This work has been inspired by GEMATICA S.r.l., a Company that specializes in the realization of advanced telecommunication systems and software solutions that firmly believes in the value of BTPLC solutions. The authors are grateful to the staff of GEMATICA for having shared their valuable experience through several useful discussions.

Conflicts of Interest: The authors declare no conflict of interest.

References

1. Xu, M.; David, J.M.; Kim, S.H. The fourth industrial revolution: Opportunities and challenges. *Int. J. Financ. Res.* **2018**, *9*, 90–95. [\[CrossRef\]](#)
2. Georgios, L.; Kerstin, S.; Theofylaktos, A. Internet of things in the context of industry 4.0: An overview. *Int. J. Entrep. Knowl.* **2019**, *7*, 4–19.
3. Bécue, A.; Praça, I.; Gama, J. Artificial intelligence, cyber-threats and Industry 4.0: Challenges and opportunities. *Artif. Intell. Rev.* **2021**, *54*, 3849–3886. [\[CrossRef\]](#)
4. Apicella, A.; Arpaia, P.; De Benedetto, E.; Donato, N.; Duraccio, L.; Giugliano, S.; Prevete, R. Employment of Domain Adaptation techniques in SSVEP-based Brain-Computer Interfaces. *IEEE Access* **2023**, *11*, 36147–36157. [\[CrossRef\]](#)
5. Kim, J.H. A review of cyber-physical system research relevant to the emerging IT trends: Industry 4.0, IoT, big data, and cloud computing. *J. Ind. Integr. Manag.* **2017**, *2*, 1750011. [\[CrossRef\]](#)
6. Dilberoglu, U.M.; Gharehpapagh, B.; Yaman, U.; Dolen, M. The role of additive manufacturing in the era of industry 4.0. *Procedia Manuf.* **2017**, *11*, 545–554. [\[CrossRef\]](#)
7. Angrisani, L.; Arpaia, P.; De Benedetto, E.; Duraccio, L.; Lo Regio, F.; Tedesco, A. Wearable Brain-Computer Interfaces based on Steady-State Visually Evoked Potentials and Augmented Reality: A Review. *IEEE Sensors J.* **2023**, *23*, 16501–16514. [\[CrossRef\]](#)
8. González-Ramos, J.; Uribe-Pérez, N.; Sendin, A.; Gil, D.; de la Vega, D.; Fernández, I.; Núñez, I.J. Upgrading the power grid functionalities with broadband power line communications: Basis, applications, current trends and challenges. *Sensors* **2022**, *22*, 4348. [\[CrossRef\]](#)
9. Majumder, A. Power line communications. *IEEE Potentials* **2004**, *23*, 4–8. [\[CrossRef\]](#)
10. Marumo, N. Simultaneous transmission and reception in radio telephony. *Proc. Inst. Radio Eng.* **1920**, *8*, 199–219. [\[CrossRef\]](#)
11. Mannan, A.; Saxena, D.; Banday, M. A study on power line communication. *Int. J. Sci. Res. Publ.* **2014**, *4*, 1–4.
12. Fraga-Lamas, P.; Fernández-Caramés, T.M.; Castedo, L. Towards the Internet of smart trains: A review on industrial IoT-connected railways. *Sensors* **2017**, *17*, 1457. [\[CrossRef\]](#) [\[PubMed\]](#)
13. Fokum, D.T.; Frost, V.S. A survey on methods for broadband internet access on trains. *IEEE Commun. Surv. Tutorials* **2010**, *12*, 171–185. [\[CrossRef\]](#)
14. Gheth, W.; Rabie, K.M.; Adebisi, B.; Ijaz, M.; Harris, G. Communication systems of high-speed railway: A survey. *Trans. Emerg. Telecommun. Technol.* **2021**, *32*, e4189. [\[CrossRef\]](#)
15. Gheth, W.; Rabie, K.M.; Adebisi, B.; Ijaz, M.; Harris, G.D. Channel modeling for overhead line equipment for train communication. In Proceedings of the 2020 IEEE International Symposium on Power Line Communications and its Applications (ISPLC), Malaga, Spain, 11–13 May 2020; pp. 1–6.
16. Slacik, J.; Mlynek, P.; Fajdiak, R.; Musil, P.; Voznak, M.; Orgon, M.; Hlavnicka, J. Capabilities and visions of broadband power-line in smart grids applications. In Proceedings of the 2019 20th International Scientific Conference on Electric Power Engineering (EPE), IEEE, Kouty nad Desnou, Czech Republic, 15–17 May 2019; pp. 1–5.
17. Franceschinis, M.; Mauro, F.; Pastrone, C.; Spirito, M.A.; Rossi, M. Predictive monitoring of train wagons conditions using wireless network technologies. In Proceedings of the 2013 XXIV International Conference on Information, Communication and Automation Technologies (ICAT), Sarajevo, Bosnia and Herzegovina, 30 October–1 November 2013; pp. 1–8.
18. Thaduri, A.; Galar, D.; Kumar, U. Railway assets: A potential domain for big data analytics. *Procedia Comput. Sci.* **2015**, *53*, 457–467. [\[CrossRef\]](#)
19. Núñez, A.; Hendriks, J.; Li, Z.; De Schutter, B.; Dollevoet, R. Facilitating maintenance decisions on the Dutch railways using big data: The ABA case study. In Proceedings of the 2014 IEEE International Conference on Big Data (Big Data), Washington, DC, USA, 27–30 October 2014; pp. 48–53.

20. Davari, N.; Veloso, B.; Costa, G.d.A.; Pereira, P.M.; Ribeiro, R.P.; Gama, J. A survey on data-driven predictive maintenance for the railway industry. *Sensors* **2021**, *21*, 5739. [[CrossRef](#)]
21. de Miranda Pinto, J.T.; Mistage, O.; Bilotta, P.; Helmers, E. Road-rail intermodal freight transport as a strategy for climate change mitigation. *Environ. Dev.* **2018**, *25*, 100–110. [[CrossRef](#)]
22. Greaves, R. The Single European Transport Area and sustainability of the transport industry. In *Sustainable and Efficient Transport*; Edward Elgar Publishing: Cheltenham, UK, 2019; pp. 34–50.
23. García-Olivares, A.; Solé, J.; Samsó, R.; Ballabrera-Poy, J. Sustainable European transport system in a 100% renewable economy. *Sustainability* **2020**, *12*, 5091. [[CrossRef](#)]
24. Lopez, G.; Matanza, J.; De La Vega, D.; Castro, M.; Arrinda, A.; Moreno, J.I.; Sendin, A. The role of power line communications in the smart grid revisited: Applications, challenges, and research initiatives. *IEEE Access* **2019**, *7*, 117346–117368. [[CrossRef](#)]
25. Belhassen, H.; Verney, E. Proof of concept of Vehicle to Infrastructure Power Line Communication link for tramway CCTV. *IEEE Intell. Transp. Syst. Mag.* **2020**, *13*, 89–98. [[CrossRef](#)]
26. Schwartz, M.; Batchelor, C. The origins of carrier multiplexing: Major George Owen Squier and AT&T. *IEEE Commun. Mag.* **2008**, *46*, 20–24.
27. Artale, G.; Cataliotti, A.; Cosentino, V.; Di Cara, D.; Fiorelli, R.; Guaiana, S.; Panzavecchia, N.; Tinè, G. A new low cost power line communication solution for smart grid monitoring and management. *IEEE Instrum. Meas. Mag.* **2018**, *21*, 29–33. [[CrossRef](#)]
28. Cano, C.; Pittolo, A.; Malone, D.; Lampe, L.; Tonello, A.M.; Dabak, A.G. State of the art in power line communications: From the applications to the medium. *IEEE J. Sel. Areas Commun.* **2016**, *34*, 1935–1952. [[CrossRef](#)]
29. Schwartz, M. Carrier-wave telephony over power lines: Early history [history of communications]. *IEEE Commun. Mag.* **2009**, *47*, 14–18. [[CrossRef](#)]
30. Du, J.; Wu, J.; Wang, R.; Lin, Z.; He, X. DC power-line communication based on power/signal dual modulation in phase shift full-bridge converters. *IEEE Trans. Power Electron.* **2016**, *32*, 693–702. [[CrossRef](#)]
31. *BS EN 50160:2007*; Voltage Characteristics of Electricity Supplied by Public Distribution Networks. BSI: London, UK, 2007
32. Berger, L.T.; Schwager, A.; Galli, S.; Pagani, P.; Schneider, D.M.; Lioe, H. *Current Power Line Communication Systems: A Survey*; CRC Press: Boca Raton, FL, USA, 2014.
33. de Oliveira, R.M.; Vieira, A.B.; Latchman, H.A.; Ribeiro, M.V. Medium access control protocols for power line communication: A survey. *IEEE Commun. Surv. Tutorials* **2018**, *21*, 920–939. [[CrossRef](#)]
34. Blazek, V.; Slanina, Z.; Petruzela, M.; Hrbáč, R.; Vysocký, J.; Prokop, L.; Misak, S.; Walendziuk, W. Error Analysis of Narrowband Power-Line Communication in the Off-Grid Electrical System. *Sensors* **2022**, *22*, 2265. [[CrossRef](#)] [[PubMed](#)]
35. *1901.1-2018*; IEEE Standard for Medium Frequency (less than 12 MHz) Power Line Communications for Smart Grid Applications. IEEE: New York, NY, USA, 2018; pp. 1–192. [[CrossRef](#)]
36. Ndjiongue, A.R.; Ferreira, H.C. Power line communications (PLC) technology: More than 20 years of intense research. *Trans. Emerg. Telecommun. Technol.* **2019**, *30*, e3575. [[CrossRef](#)]
37. Song, J.; Ding, W.; Yang, F.; Yang, H.; Yu, B.; Zhang, H. An indoor broadband broadcasting system based on PLC and VLC. *IEEE Trans. Broadcast.* **2015**, *61*, 299–308. [[CrossRef](#)]
38. Colen, G.R.; Marques, C.A.; Oliveira, T.R.; de Campos, F.P.; Ribeiro, M.V. Measurement setup for characterizing low-voltage and outdoor electric distribution grids for PLC systems. In Proceedings of the 2013 IEEE PES Conference on Innovative Smart Grid Technologies (ISGT Latin America), IEEE, Sao Paulo, Brazil, 15–17 April 2013; pp. 1–5.
39. Righetti, F.; Vallati, C.; Anastasi, G.; Masetti, G.; Di Giandomenico, F. Failure management strategies for IoT-based rail-ways systems. In Proceedings of the 2020 IEEE international conference on smart computing (SMARTCOMP), Bologna, Italy, 14–17 September 2020; pp. 386–391.
40. Power Line Communication Market. Available online: <https://www.gminsights.com/industry-analysis/power-line-communication-plc-market> (accessed on 10 March 2023).
41. Ninth IRG-Rail Market Monitoring Report. Available online: https://www.irk-rail.eu/irk/documents/market-monitoring/312_2021.html (accessed on 19 June 2023).
42. Cañete, F.; Dostert, K.; Galli, S.; Katayama, M.; Lampe, L.; Lienard, M.; Mashayekhi, S.; Michelson, D.; Nassar, M.; Pighi, R.; et al. Channel characterization. In *Power Line Communications: Principles, Standards and Applications from Multimedia to Smart Grid*; John Wiley & Sons: Hoboken, NJ, USA, 2016; pp. 8–177.
43. Garczynski, J. Les Transmissions Par Courants Porteurs Sur Les Lignes a Haute Tension. *L'Onde Electr.* **1933**, *12*, 140–141.
44. Solaz, M.; Simon, J.; Sendin, A.; Andersson, L.; Maurer, M. High Availability solution for medium voltage BPL communication networks. In Proceedings of the 18th IEEE International Symposium on Power Line Communications and Its Applications, Glasgow, UK, 30 March–2 April 2014; pp. 162–167.
45. Giraneza, M.; Abo-Al-Ez, K. Power line communication: A review on couplers and channel characterization. *AIMS Electron. Electr. Eng.* **2022**, *6*, 265–284. [[CrossRef](#)]
46. Sibanda, M.P.; van Rensburg, P.A.J.; Ferreira, H.C. Passive, transformerless coupling circuitry for narrow-band power-line communications. In Proceedings of the 2009 IEEE International Symposium on Power Line Communications and Its Applications, Dresden, Germany, 29 March–1 April 2009; pp. 125–130.

47. Yang, S.; Li, H.; Goldberg, M.; Carcelle, X.; Onado, F.; Rowland, S. Broadband impedance matching circuit design using numerical optimisation techniques and field measurements. In Proceedings of the 2007 IEEE International Symposium on Power Line Communications and Its Applications, Pisa, Italy, 11 June 2007; pp. 425–430.
48. Da Silva Costa, L.G.; de Queiroz, A.C.M.; Adebisi, B.; da Costa, V.L.R.; Ribeiro, M.V. Coupling for power line communications: A survey. *J. Commun. Inf. Syst.* **2017**, *32*, 8–22. [[CrossRef](#)]
49. Vines, R.M.; Trussell, H.J.; Shuey, K.C.; O’Neal, J.B. Impedance of the residential power-distribution circuit. *IEEE Trans. Electromagn. Compat.* **1985**, *27*, 6–12. [[CrossRef](#)]
50. Kikkert, C.J. MV to LV transformer PLC bypass coupling networks for a low cost Smart Grid rollout. In Proceedings of the 2011 IEEE PES Innovative Smart Grid Technologies, Perth, WA, Australia, 13–16 November 2011; pp. 1–6.
51. Ferreira, H.C.; Lampe, L.; Newbury, J.; Swart, T.G. *Power Line Communications: Theory and Applications For Narrowband and Broadband Communications over Power Lines*; John Wiley & Sons: Hoboken, NJ, USA, 2011.
52. Barmada, S.; Musolino, A.; Raugi, M. Innovative model for time-varying power line communication channel response evaluation. *IEEE J. Sel. Areas Commun.* **2006**, *24*, 1317–1326. [[CrossRef](#)]
53. Zimmermann, M.; Dostert, K. A multipath model for the powerline channel. *IEEE Trans. Commun.* **2002**, *50*, 553–559. [[CrossRef](#)]
54. Galli, S.; Scaglione, A.; Wang, Z. Power line communications and the smart grid. In Proceedings of the 2010 First IEEE International Conference on Smart Grid Communications, Gaithersburg, MD, USA, 4–6 October 2010; pp. 303–308.
55. Corripio, F.J.C.; Arrabal, J.A.C.; Del Río, L.D.; Munoz, J.E. Analysis of the cyclic short-term variation of indoor power line channels. *IEEE J. Sel. Areas Commun.* **2006**, *24*, 1327–1338. [[CrossRef](#)]
56. Picorone, A.A.; de Oliveira, T.R.; Sampaio-Neto, R.; Khosravy, M.; Ribeiro, M.V. Channel characterization of low voltage electric power distribution networks for PLC applications based on measurement campaign. *Int. J. Electr. Power Energy Syst.* **2020**, *116*, 105554. [[CrossRef](#)]
57. Directive 2014/30/EU of the European Parliament and of the Council of 26 February 2014 on the Harmonization of the Laws of the Member States Relating to Electromagnetic Compatibility; Artesyn Technologies: Boca Raton, FL, US, 2014.
58. Richards, J.C. *Potential Interference from Broadband over Power Line (Bpl) Systems To Federal Government Radiocommunications at 1.7–80 Mhz-Phase 2 Study*; Technical Report; Institute for Telecommunication Sciences: Boulder, CO, USA, 2007.
59. Li, Y.; Dawalibi, F.; Raymond, R. Electromagnetic compatibility analysis of power line and railway sharing the same right-of-way corridor: A practical case study. In Proceedings of the 2010 International Conference on Future Power and Energy Engineering, Shenzhen, China, 26–27 June 2010; pp. 103–106.
60. Vick, R. Radiated emission caused by in-house PLC-systems. In Proceedings of the IEEE International Symposium on Power Line Communications and Its Applications (ISPLC), Malmö, Sweden, 4–6 April 2001.
61. Amirshahi, P.; Kavehrad, M. Medium voltage overhead power-line broadband communications; transmission capacity and electromagnetic interference. In Proceedings of the International Symposium on Power Line Communications and Its Applications, 2005, IEEE, Vancouver, BC, Canada, 6–8 April 2005; pp. 2–6.
62. Barros, L.A.; Tanta, M.; Martins, A.P.; Afonso, J.L.; Pinto, J. STATCOM evaluation in electrified railway using V/V and Scott power transformers. In Proceedings of the Sustainable Energy for Smart Cities: First EAI International Conference, SESC 2019, Braga, Portugal, 4–6 December 2019; Proceedings 1; Springer: Berlin/Heidelberg, Germany, 2020; pp. 18–32.
63. Barros, L.A.; Martins, A.P.; Pinto, J.G. Balancing the Active Power of a Railway Traction Power Substation with an sp-RPC. *Energies* **2023**, *16*, 3074. [[CrossRef](#)]
64. Song, S.; Liu, J.; Ouyang, S.; Chen, X. A modular multilevel converter based Railway Power Conditioner for power balance and harmonic compensation in Scott railway traction system. In Proceedings of the 2016 IEEE 8th International Power Electronics and Motion Control Conference (IPEMC-ECCE Asia), IEEE, Hefei, China, 22–26 May 2016; pp. 2412–2416.
65. Barros, L.A.; Tanta, M.; Martins, A.P.; Afonso, J.L.; Pinto, J. Opportunities and challenges of power electronics systems in future railway electrification. In Proceedings of the 2020 IEEE 14th International Conference on Compatibility, Power Electronics and Power Engineering (CPE-POWERENG), Setubal, Portugal, 8–10 July 2020; Volume 1, pp. 530–537.
66. Meng, H.; Guan, Y.L.; Chen, S. Modeling and analysis of noise effects on broadband power-line communications. *IEEE Trans. Power Deliv.* **2005**, *20*, 630–637. [[CrossRef](#)]
67. Pinomaa, A.; Ahola, J.; Kosonen, A.; Nuutinen, P. Noise analysis of a power-line communication channel in an LVDC smart grid concept. In Proceedings of the 2013 IEEE 17th International Symposium on Power Line Communications and Its Applications, Johannesburg, South Africa, 24–27 March 2013; pp. 41–46.
68. Kawaguchi, A.; Okada, H.; Yamazato, T.; Katayama, M. Correlations of noise wavements at different outlets in a power-line network. In Proceedings of the 2006 IEEE International Symposium on Power Line Communications and its Applications, Manchester, UK, 21–22 March 2006.
69. Sabolic, D.; Bazant, A.; Malaric, R. Signal propagation modeling in power-line communication networks. *IEEE Trans. Power Deliv.* **2005**, *20*, 2429–2436. [[CrossRef](#)]
70. EN 55032:2016; Electromagnetic Compatibility of Multimedia Equipment—Emission Requirements. European Committee for Electrotechnical Standardization: Brussels, Belgium, 2016.
71. EN 50561-3:2016; Power Line Communication Apparatus Used in Low-Voltage Installations-Radio Disturbance Characteristics-Limits and Methods of Measurement-Part 3: Apparatus Operating Above 30 MHz. European Committee for Electrotechnical Standardization: Brussels, Belgium, 2016.

72. Ma, Y.; So, P.; Gunawan, E. Performance analysis of OFDM systems for broadband power line communications under impulsive noise and multipath effects. *IEEE Trans. Power Deliv.* **2005**, *20*, 674–682. [[CrossRef](#)]
73. Andreadou, N.; Pavlidou, F.N. Modeling the noise on the OFDM power-line communications system. *IEEE Trans. Power Deliv.* **2009**, *25*, 150–157. [[CrossRef](#)]
74. Liang, D.; Guo, H.; Zheng, T. Real-time impedance estimation for power line communication. *IEEE Access* **2019**, *7*, 88107–88115. [[CrossRef](#)]
75. Gotz, M.; Rapp, M.; Dostert, K. Power line channel characteristics and their effect on communication system design. *IEEE Commun. Mag.* **2004**, *42*, 78–86. [[CrossRef](#)]
76. Yang, S.; Franklin, G.A. Effects of segmented shield wires on signal attenuation of power-line carrier channels on overhead transmission lines—Part I: Modeling method. *IEEE Trans. Power Deliv.* **2012**, *28*, 427–433. [[CrossRef](#)]
77. Barmada, S.; Tucci, M.; Romano, F. Transmission Channel Analysis for Broadband Communication over Multiconductor UIC Cables Onboard Regional Trains. *Energies* **2019**, *12*, 497. [[CrossRef](#)]
78. Tonello, A.M.; Pittolo, A. Considerations on narrowband and broadband power line communication for smart grids. In Proceedings of the 2015 IEEE International Conference on Smart Grid Communications (SmartGridComm), Miami, FL, USA, 2–5 November 2015; pp. 13–18.
79. Kikkert, C.J.; Perutka, D. Calculating radiation from power lines for power line communications. In *MATLAB for Engineers—Applications in Control, Electrical Engineering, IT and Robotics*; Intech: Houston, TX, USA, 2011.
80. Kiedrowski, P.; Saganowski, L. Method of Assessing the Efficiency of Electrical Power Circuit Separation with the Power Line Communication for Railway Signs Monitoring. *Transp. Telecommun. J.* **2021**, *22*, 407–416. [[CrossRef](#)]
81. Araneo, R.; Celozzi, S.; Lovat, G. Design of impedance matching couplers for power line communications. In Proceedings of the 2009 IEEE International Symposium on Electromagnetic Compatibility, Austin, TX, USA, 17–21 August 2009; pp. 64–69.
82. Versolatto, F.; Tonello, A.M. PLC channel characterization up to 300 MHz: Frequency response and line impedance. In Proceedings of the 2012 IEEE Global Communications Conference (GLOBECOM), Anaheim, CA, USA, 3–7 December 2012; pp. 3525–3530.
83. Fernández, I.; Arrinda, A.; Angulo, I.; De La Vega, D.; Uribe-Pérez, N.; Llano, A. Field trials for the empirical characterization of the low voltage grid access impedance from 35 kHz to 500 kHz. *IEEE Access* **2019**, *7*, 85786–85795. [[CrossRef](#)]
84. Antoniali, M.; Tonello, A.M.; Versolatto, F. A study on the optimal receiver impedance for SNR maximization in broadband PLC. *J. Electr. Comput. Eng.* **2013**, *2013*, 635086. [[CrossRef](#)]
85. Galli, S. A novel approach to the statistical modeling of wireline channels. *IEEE Trans. Commun.* **2011**, *59*, 1332–1345. [[CrossRef](#)]
86. Oliveira, T.R.; Picorone, A.A.; Netto, S.L.; Ribeiro, M.V. Characterization of Brazilian in-home power line channels for data communication. *Electr. Power Syst. Res.* **2017**, *150*, 188–197. [[CrossRef](#)]
87. Picorone, A.A.M.; Neto, R.S.; Ribeiro, M.V. Coherence time and sparsity of Brazilian outdoor PLC channels: A preliminary analysis. In Proceedings of the 18th IEEE International Symposium on Power Line Communications and Its Applications, Glasgow, UK, 30 March–2 April 2014; pp. 1–5.
88. Tlich, M.; Avril, G.; Zeddani, A. Coherence Bandwidth and its Relationship with the RMS delay spread for PLC channels using Measurements up to 100 MHz. In Proceedings of the Home Networking: First IFIP WG 6.2 Home Networking Conference (IHN'2007), Paris, France, 10–12 December 2007; Springer: Berlin/Heidelberg, Germany, 2008; pp. 129–142.
89. Liu, W.; Widmer, H.P.; Aldis, J.; Kaltenschnee, T. Nature of power line medium and design aspects for broadband PLC system. In Proceedings of the 2000 International Zurich Seminar on Broadband Communications. Accessing, Transmission, Networking. Proceedings (Cat. No. 00TH8475), Zurich, Switzerland, 15–17 February 2000; pp. 185–189.
90. Liu, H.; Song, J.; Zhao, B.; Li, X. Channel study for medium-voltage power network. In Proceedings of the 2006 IEEE International Symposium on Power Line Communications and Its Applications, Orlando, FL, USA, 26–29 March 2006; pp. 245–250.
91. Versolatto, F.; Tonello, A.M.; Tornelli, C.; Della Giustina, D. Statistical analysis of broadband underground medium voltage channels for PLC applications. In Proceedings of the 2014 IEEE International Conference on Smart Grid Communications (SmartGridComm), Venice, Italy, 3–6 November 2014; pp. 493–498.
92. Amirshahi, P.; Kavehrad, M. High-frequency characteristics of overhead multiconductor power lines for broadband communications. *IEEE J. Sel. Areas Commun.* **2006**, *24*, 1292–1303. [[CrossRef](#)]
93. Lazaropoulos, A.G. Broadband transmission and statistical performance properties of overhead high-voltage transmission networks. *J. Comput. Netw. Commun.* **2012**, *2012*. [[CrossRef](#)]
94. Zhai, M.Y. Transmission characteristics of low-voltage distribution networks in China under the smart grids environment. *IEEE Trans. Power Deliv.* **2010**, *26*, 173–180. [[CrossRef](#)]
95. Tonello, A.M.; Versolatto, F.; Béjar, B.; Zazo, S. A fitting algorithm for random modeling the PLC channel. *IEEE Trans. Power Deliv.* **2012**, *27*, 1477–1484. [[CrossRef](#)]
96. Barnes, J.S. A physical multi-path model for power distribution network propagation. In Proceedings of the Proceedings of International Symposium on Power-line Communications and its Applications, Jeju City, Republic of Korea, 4–6 April 1998; pp. 76–89.
97. Meng, H.; Chen, S.; Guan, Y.; Law, C.; So, P.; Gunawan, E.; Lie, T. Modeling of transfer characteristics for the broadband power line communication channel. *IEEE Trans. Power Deliv.* **2004**, *19*, 1057–1064. [[CrossRef](#)]
98. Galli, S.; Banwell, T.C. A deterministic frequency-domain model for the indoor power line transfer function. *IEEE J. Sel. Areas Commun.* **2006**, *24*, 1304–1316. [[CrossRef](#)]

99. Tonello, A.M.; Pittolo, A.; Girotto, M. Power line communications: Understanding the channel for physical layer evolution based on filter bank modulation. *IEICE Trans. Commun.* **2014**, *97*, 1494–1503. [[CrossRef](#)]
100. Tonello, A.M.; Zheng, T. Bottom-up transfer function generator for broadband PLC statistical channel modeling. In Proceedings of the 2009 IEEE International Symposium on Power Line Communications and Its Applications, Dresden, Germany, 29 March–1 April 2009; pp. 7–12.
101. Tonello, A.M.; Versolatto, F. Bottom-up statistical PLC channel modeling—Part I: Random topology model and efficient transfer function computation. *IEEE Trans. Power Deliv.* **2011**, *26*, 891–898. [[CrossRef](#)]
102. Galli, S.; Banwell, T. A novel approach to the modeling of the indoor power line channel-Part II: Transfer function and its properties. *IEEE Trans. Power Deliv.* **2005**, *20*, 1869–1878. [[CrossRef](#)]
103. Akinnikawe, A.; Butler-Purry, K.L. Investigation of broadband over power line channel capacity of shipboard power system cables for ship communication networks. In Proceedings of the 2009 IEEE Power & Energy Society General Meeting, Calgary, AB, Canada, 26–30 July 2009; pp. 1–9.
104. Esmailian, T.; Kschischang, F.R.; Glenn Gulak, P. In-building power lines as high-speed communication channels: Channel characterization and a test channel ensemble. *Int. J. Commun. Syst.* **2003**, *16*, 381–400. [[CrossRef](#)]
105. Paul, C.R. *Analysis of Multiconductor Transmission Lines*; John Wiley & Sons: Hoboken, NJ, USA, 2007.
106. Araneo, R.; Barmada, S.; Celozzi, S.; Raugi, M. Two-port equivalent of PCB discontinuities in the wavelet domain. *IEEE Trans. Microw. Theory Tech.* **2005**, *53*, 907–918. [[CrossRef](#)]
107. Issa, F.; Sartenaer, T.; Marthe, E.; Rachidi, F.; Korovkin, N.; Duteau, S.; Pacaud, A. Analysis of power line communication networks using a new approach based on scattering parameters matrix. In Proceedings of the 2002 IEEE International Symposium on Electromagnetic Compatibility, Minneapolis, MN, USA, 19–23 August 2002; Volume 2, pp. 1043–1047.
108. Canete, F.J.; Cortes, J.A.; Diez, L.; Entrambasaguas, J.T. A channel model proposal for indoor power line communications. *IEEE Commun. Mag.* **2011**, *49*, 166–174. [[CrossRef](#)]
109. Tonello, A.M.; Versolatto, F. New results on top-down and bottom-up statistical PLC channel modeling. In Proceedings of the Third Workshop on Power Line Communications, Udine, Italy, 1–2 October 2009; pp. 1–2.
110. Tang, C.J.; Pan, J.M. An Experimental Model of the Mobile Power-Line Communication Systems. In Proceedings of the 2006 ICS International Computer Conference, Merin, Czech Republic, 21 January 2006.
111. Barmada, S.; Gaggelli, A.; Musolino, A.; Rizzo, R.; Raugi, M.; Tucci, M. Design of a PLC system onboard trains: Selection and analysis of the PLC channel. In Proceedings of the 2008 IEEE International Symposium on Power Line Communications and Its Applications, Jeju, Republic of Korea, 2–4 April 2008; pp. 13–17.
112. Barmada, S.; Musolino, A.; Rizzo, R.; Tucci, M.; Gaggelli, A.; Masini, P. Modeling of UIC cables in railway systems for their use as power line communication channels. *Appl. Comput. Electromagn. Soc. J. (ACES)* **2009**, *24*, 609–617.
113. Tang, C.J., Jr.; Zhang, W.P., Jr. Simulation and Analysis of Mobile Power-Line Communication On High-Speed Electrical Railway System. In Proceedings of the 2009 NCS National Computer Conference, Chennai, India, 27–29 December 2011.
114. Francis, A.; Titus, G. Channel capacity analysis of railway power lines. In Proceedings of the 2011 International Conference on Emerging Trends in Electrical and Computer Technology, Nagercoil, India, 23–24 March 2011; pp. 74–77.
115. Barmada, S.; Tucci, M.; Romano, F. Channel Capacity Evaluation of UIC Cables for High Speed Data Transmission Onboard Regional Trains. In Proceedings of the Proceedings of the Third International Conference on Railway Technology: Research, Development and Maintenance, Cagliari, Italy, 5–8 April 2016; pp. 5–8.
116. UIC 558 Union. *Ligne de Telecommande et D'information. Caracteristiques Techniques Unifiees por L'equipement des Voitures RIC*; Internationale des Chemins de fer: Paris, France, 1994.
117. Barmada, S.; Raugi, M. Transient numerical solutions of nonuniform MTL equations with nonlinear loads by wavelet expansion in time or space domain. *IEEE Trans. Circuits Syst. Fundam. Theory Appl.* **2000**, *47*, 1178–1190. [[CrossRef](#)]

Disclaimer/Publisher's Note: The statements, opinions and data contained in all publications are solely those of the individual author(s) and contributor(s) and not of MDPI and/or the editor(s). MDPI and/or the editor(s) disclaim responsibility for any injury to people or property resulting from any ideas, methods, instructions or products referred to in the content.