

Recent analysis of the ITER ion cyclotron antenna with the TOPICA code

Original

Recent analysis of the ITER ion cyclotron antenna with the TOPICA code / Milanesio, D., Helou, W., Polli, V., Durodié, F., Lamalle, P., Louche, F., Zhang, W.. - In: AIP CONFERENCE PROCEEDINGS. - ISSN 0094-243X. - ELETTRONICO. - 2984:(2023). (24th Topical Conference on Radio-Frequency Power in Plasmas Annapolis, USA 26–28 September 2022) [10.1063/5.0162590].

Availability:

This version is available at: 11583/2981971 since: 2023-09-20T09:52:15Z

Publisher:

AIP Publishing

Published

DOI:10.1063/5.0162590

Terms of use:

This article is made available under terms and conditions as specified in the corresponding bibliographic description in the repository

Publisher copyright

AIP postprint/Author's Accepted Manuscript e postprint versione editoriale/Version of Record

(Article begins on next page)

Recent Analysis of the ITER Ion Cyclotron Antenna with the TOPICA Code

D. Milanesio,^{1, a)} W. Helou,² V. Polli,^{2, 3} F. Durodié,⁴ P. Lamalle,² F. Louche,⁴
and W. Zhang^{5, 6}

¹⁾*Politecnico di Torino, Torino, Italy*

²⁾*ITER Organization, Route de Vinon-sur-Verdon, CS 90 046, 13067 St. Paul Lez Durance Cedex, France*

³⁾*Capgemini Engineering - France, Parc du Golf – Bat.17, 350 Av JRG Gautier de la Lauziere, CS40514, 13593 Aix en Provence Cedex 3*

⁴⁾*LPP-ERM/KMS, TEC Partner, Brussels, Belgium*

⁵⁾*Max-Planck-Institut für Plasmaphysik, Boltzmannstr. 2, 85748 Garching, Germany*

⁶⁾*Institute of Plasma Physics, Chinese Academy of Sciences, Hefei 230031, China*

^{a)}*Corresponding author: daniele.milanesio@polito.it*

Abstract. Plasma heating in the Ion Cyclotron Range of Frequencies (ICRF) is adopted in most of the existing nuclear fusion experiments and is also one of the three auxiliary heating systems of ITER. Two identical ICRF antennas will be installed in ITER with the aim of delivering 10MW per antenna to the plasma for the baseline design configuration (upgradable to 20 MW/antenna). The ability to perform radio-frequency simulations of the ICRF antenna detailed geometry in front of a realistic plasma description and to obtain the antenna input parameters, the electric currents on conductors and the radiated field distribution next to the antenna is important to optimize the feeding circuit, excitation, and to evaluate and predict the overall system performances. In this work, we analyze the current ITER ICRF launcher, for the first time including the surrounding cavity between the port plug and the port extension, and a portion of the blanket tiles in the TOPICA code; the geometrical description of the antenna has reached an unprecedented level of accuracy. The ITER ICRF antennas have been the object of a comprehensive analysis, varying the working frequency, the plasma conditions and the poloidal and toroidal phasings between the feeding transmission lines. The performances of the antennas have been documented in terms of input parameters, power coupled to plasma and electric fields, for a reference set of ITER plasma equilibria and assuming a maximum voltage on the system.

INTRODUCTION

Ion Cyclotron Resonance Heating (ICRF) is one of the auxiliary heating systems in ITER [1]. In this respect, the capability to accurately predict the IC antenna behavior in terms of input parameters, power coupled to plasma, electric currents and radiated fields is crucial to assist its design.

This paper contains an accurate analysis of the antenna performances in the required working frequency range given several different loading conditions, with the help of the TOPICA code. The paper first provides an overall description of the TOPICA code, of the simulated geometries and of the set of assumed reference plasma profiles respectively. Then it reports the analysis of the latest optimized geometry with the antenna plug/port cavity in place (it is the cavity that is formed by the antenna and the port where it is installed). It is important to stress here that this paper fully documents only one geometry of the TOPICA related actions for the analysis of the ITER IC launcher. However, being this a wider cooperative design task, this paper has to be considered in synergy with the other published material on the same topic. In particular, interested readers can refer to [2], [3], [4] and [5] for the COMSOL and Petra-M modelling of the ITER ICRF antennas and the excellent agreement with the TOPICA results. Also, references [6] and [7] analyse the fields extracted from the TOPICA simulations (near fields in front of the antenna, and fields inside the antenna plug/port cavity respectively).

ADOPTED TOOLS AND SETUP

The TOPICA code

All the results reported here have been obtained using the TOPICA code. In order to better understand the peculiarities of this designing tool, a few words are required as a preamble. We refer the interested reader to [8] and [9] for a more detailed description of the code.

TOPICA is a tool realized for the 3D/1D simulation of ICRF, i.e. accounting for antennas in a realistic 3D geometry and with an accurate 1D plasma model. The approach to the problem is based on an integral-equation formulation for the self-consistent evaluation of the current distribution on conductors. The environment is subdivided into two coupled regions: the plasma region and the vacuum region. The two problems are linked by means of electromagnetic current distribution on the interface between the two regions, often referred to as *aperture*. In the vacuum region, all the calculations are executed in the spatial domain while in the plasma region calculations are executed in the spectral domain. The plasma enters the formalism via a surface impedance matrix; for this reason, any plasma model can be used. At present, a modified version of FELICE code is adopted [10], which affords density and temperature profiles, and Finite Larmor Radius (FLR) effects. The source term directly models the TEM mode of the coax feeding the antenna and the current in the coax is determined self-consistently, giving the way to accurately compute the antenna input parameters.

The TOPICA code is also fully parallelized. This feature leads not only to a remarkable saving in terms of computation time but also to the removal of any limitation on the complexity of the simulated geometries. TOPICA is currently installed on the MARCONI cluster at CINECA (www.hcp.cineca.it), characterized by 3188 computing nodes, featuring Intel Xeon Skylake (SKL) processors and capable of a total peak performance of about 20 PFlop/s.

List of geometries

In terms of geometrical description, all simulated models share the same approach, i.e. the full array of 24 straps is enclosed within a cavity, as required by the TOPICA formulation, including a portion of the input transmission lines and, if available, a Faraday Screen (FS). In order to provide an even more precise description of the antenna behavior, a part of the blanket shielding modules (BSM), the four port junction (4PJ) and the grounding connections are also included in some models. It is important to stress that the geometries simulated within this design activity are by far the largest, both geometrically and in terms of the number of mesh unknowns, that have ever been analyzed with this numerical tool.

While addressing the reader to [11] and to [12] for a detailed analysis of the simulated geometries, we would like to list here the main steps of this activity. The first geometry was the Preliminary Design Review (PDR) antenna from 2010 (labeled here as "CY8a"). This was the final geometry coming out of the first design phase ([13], [14]) and it was a top-bottom asymmetric launcher characterized by a curved antenna-plasma interface (i.e. *aperture*) and by a simplified FS. The curved antenna-plasma interface mimics the last plasma closed surface, which is located at a varying distance from the straps depending on the toroidal and poloidal position (see Table I for further details). A new "CY8b" geometry first became the reference launcher for the recent analysis; this antenna includes a simplified aperture with top/bottom and left/right symmetry.

The next group of geometries was characterized by a top-bottom symmetry and by a reduced distance between the straps in the toroidal direction, as dictated by the mechanical review of the 2012 PDR antenna. A first model, namely "CY9" was used to verify the impact of the FS, by testing it with a simplified version, with a more realistic design and without FS at all. For this model, the same simplified aperture of "CY8b" was considered. Eventually, "CY10" can be considered as the final geometry and it has been extensively tested and reported in [11]; for this geometry, a more realistic aperture based on recent equilibrium studies was adopted. The next model, "CY11", included the presence of the 4 port junction (4PJ) and it is detailed in [12] instead.

The last antenna, namely "CY12", is the antenna model used in this paper and it includes the antenna plug/port cavity, as depicted in Figure 1. Figure 2 reports on the left the position of the surfaces where the electric field was computed within the vacuum volume of the TOPICA model, while a front view of the meshed launcher is depicted on the right. This analysis is extremely important to determine if the presence of the cavity has an impact on the antenna input parameters and on the electric field distribution. This paper describes the performances of this antenna with a large number of plasma profiles for five frequency points; please refer to the correspondent section for an accurate description of the adopted loadings.

Table I summarizes some relevant features of the most important geometries listed before.

List of plasma profiles

Before proceeding with the description of all plasma cases, it is essential to recall how a plasma profile is handled by TOPICA. First of all, the part of the profile that enters the vacuum volume of the TOPICA model (i.e. that lies

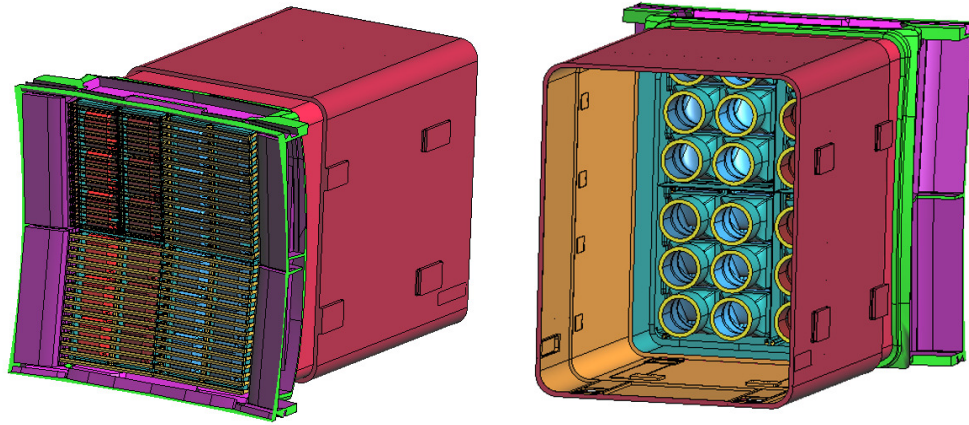

FIGURE 1. Front and back view of the "CY12" launcher.

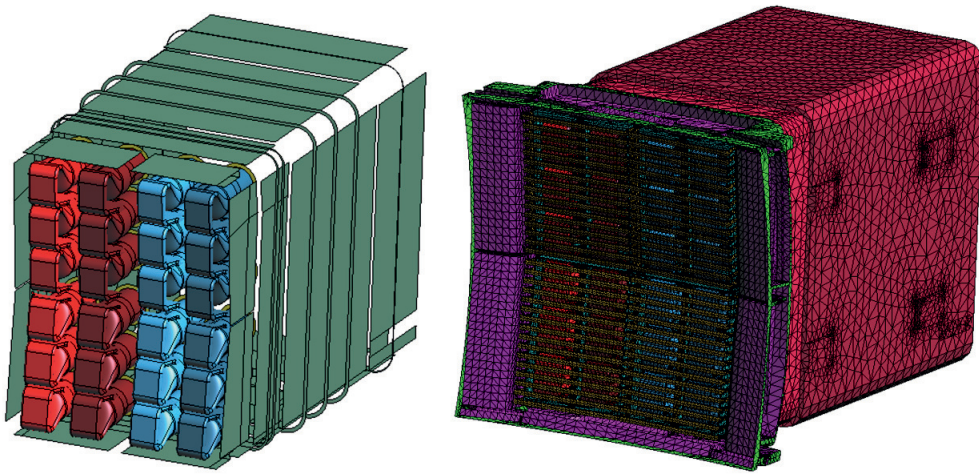

FIGURE 2. Position of the surfaces along the cavity where the electric field was computed for the "CY12" launcher (left) and front view of the meshed geometry (right).

beyond the previously mentioned aperture) has to be immediately neglected, being that region in vacuum. A further action is then performed to take care of the $S=0$ resonance (lower hybrid resonance), if present, which is not correctly handled by FELICE code. The portion of the profile where the resonance is located is removed and substituted with an "equivalent" layer of vacuum of the same thickness, hence keeping constant the separatrix-antenna distance. The amount of equivalent vacuum is on average of the order of a few centimeters and it is not needed in approximately 25% of the simulated plasma cases. This can be considered the most conservative approach in terms of power coupled to plasma, as documented in [12].

The equivalence theorem adopted in TOPICA formulation determines the presence of an infinitely extending ground plane at the aperture position, which reproduces the effect of the first wall (FW). Profiles can also be rigidly shifted in the radial direction to assess the impact on the antenna input parameters and on the transferred power. When moving the profile towards the antenna, the rigid shift is obtained by removing the low density part of it. Given the TOPICA formulation, this approach is considerably faster than assuming a constant aperture-FW position and moving the antenna radially, because only the interaction with plasma has to be re-computed. Conversely, when moving the profile away from the antenna, a few centimeters from the low field side are added without removing any central density; this is allowed since no reflected power is assumed within FELICE after 50cm from the antenna mouth. Please notice that a negative shift is considered from the antenna perspective, i.e. corresponds to the plasma profile getting closer to the antenna itself.

Geometry label	CY8a	CY8b	CY9(a/b/c)	CY10	CY11	CY12
Motivation	2010 PDR	Reference	Impact of mesh, FS, strap inter spaces modification and the strap short circuit	Final model and impact of stretching procedure	Impact of 4PJ	Impact of grounding
Strap-plasma distance	40÷94 mm	78÷98 mm	78÷98 mm	65÷110 mm	as CY10	as CY10
FS description	2010 PDR	Simplified	Different versions (no FS, very detailed FS, simplified FS)	Simplified	as CY10	as CY10
Left-right Symmetry	Yes	Yes	Yes	Yes	Yes	Yes
Top-bottom symmetry	top:6.76° bottom:4.78°	Yes (6.76°)	as CY8b	as CY8b	as CY8b	as CY8b
Total unknowns	172k	181k	145k÷267k	263k	277k	291k
Unknowns on aperture	3552	4552	2550÷5124	4720	as CY10	as CY10
Mesh max size on conductors	8.5 cm	8 cm	5 cm	8 cm	as CY10	as CY10
Mesh max size on aperture	9.2 cm	7.4 cm	7.4÷9.8 cm	8.0 cm	as CY10	as CY10
Mesh min size on aperture	6.0 cm	5.1 cm	5.1÷6.8 cm	5.6 cm	as CY10	as CY10

TABLE I. Most relevant simulated geometries

While addressing again the interested reader to [12] for a detailed description of the loaded plasma profiles, we briefly introduce them here.

Two reference plasma profiles were originally defined by ITER Organization in 2010 (plasma composition: 50% D, 50% T, magnetic field at magnetic axis: 5.3T); they represent the extremes within which the ITER plasmas are expected, given the current uncertainties on edge physics. Radial shifts of 2cm, 4cm and 5cm towards the antenna were considered for the low density profile, while the high density one was loaded only after a 4cm shift away from the antenna.

Ten additional plasma profiles [15], obtained with the latest self-consistent core-edge modelling, were then provided by ITER IO in 2020, namely Case1 (low far SOL density LO and high far sol density HI, about 56% D and 44% T, 5.4T), Case2 (LO and HI, about 48% He4 and 4% H, 2.7T), Case3 (LO and HI, about 51% D and 49% T, 5.4T), Case4 (LO and HI, about 52% D and 48% T, 5.4T) and Case5 (LO and HI, about 48% He4 and 4% H, 2.7T). Radial shifts of 2cm, 4cm and 5cm towards the antenna were implemented for Case1 LO and Case2 LO profiles. The LO and HI cases differ only in the SOL region, the main plasma density is the same. In order to verify the effect of local gas puffing on the antenna performances, four cases were initially added, namely Case1 IPP, Case4 IPP, Case22 IPP and Case23 IPP (all 50% D and 50% T, 5.2T). As an example, Figure 3 reports all 2020 profiles.

Finally, the 2010 low density scenario was also rigidly shifted 150cm far from the antenna mouth, in order to reproduce the effect of vacuum loading.

ANALYSIS OF THE "CY12" GEOMETRY WITH THE ANTENNA PLUG / PORT CAVITY

As an example of the analysis performed with "CY12" geometry, the power coupled to the plasma and the near electric fields (E-fields at 2-3mm in front of the antenna) are shown in Figures 4 and 5 at 55MHz and 47.5MHz. Figure 4 shows that the presence of the cavity does not influence at all the power coupled to plasma outside the resonance frequency (around 47.5MHz, see also [7]) and for the typical H&CD phasings ($0\pi0\pi$, $0\pi\pi0$, tapered $0\pi0\pi$, +CD, etc.). The only exception is monopole phasing (which is not going to be adopted), for which the relative error is remarkable at all frequencies and above 20% in some cases. Figure 5 documents the effect of the antenna plug/port cavity on the near fields computed close to its resonance, going from an average value (in magnitude) of about 12 kV/m to 21 kV/m.

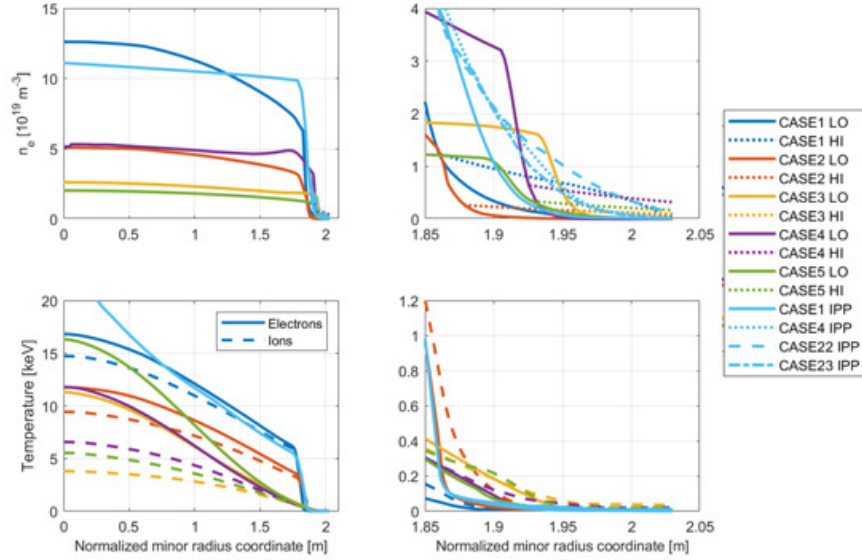

FIGURE 3. 2020 plasma profiles. Electron density is displayed on top, while ion and electron temperature are reported below; for both plots, a zoomed view of the region in front of the antenna is shown on the right.

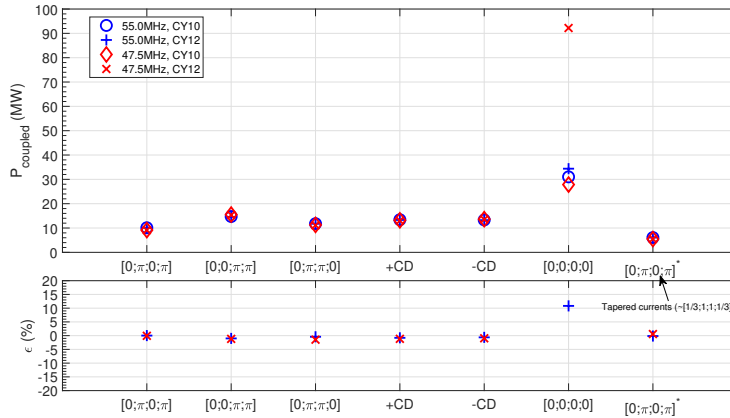

FIGURE 4. Coupled power for the low density 2010 baseline scenario as a function of frequency (47.5MHz and 55MHz are shown) for the "CY10" and the "CY12" geometries (top) and relative error (bottom). A peak voltage of 45kV is assumed in the circuit, with several toroidal phasings and a constant 0/-90 poloidal one. The relative error is computed as $(P_{CY12} - P_{CY10})/P_{CY10}$ for each case.

CONCLUSION

This paper details one of the geometries simulated with TOPICA within the frame of the ITER IC antenna design. To be more specific, "CY12" launcher is the same as the reference ITER IC antenna ("CY10"), with the addition of the antenna plug/port cavity. The comparison of the antenna input parameters and of the electric fields along the cavity with the reference model showed that the presence of the antenna plug/port cavity can have a substantial impact (above all on near fields) around the cavity resonance frequency, while it can be neglected elsewhere, in particular for heating and current-drive.

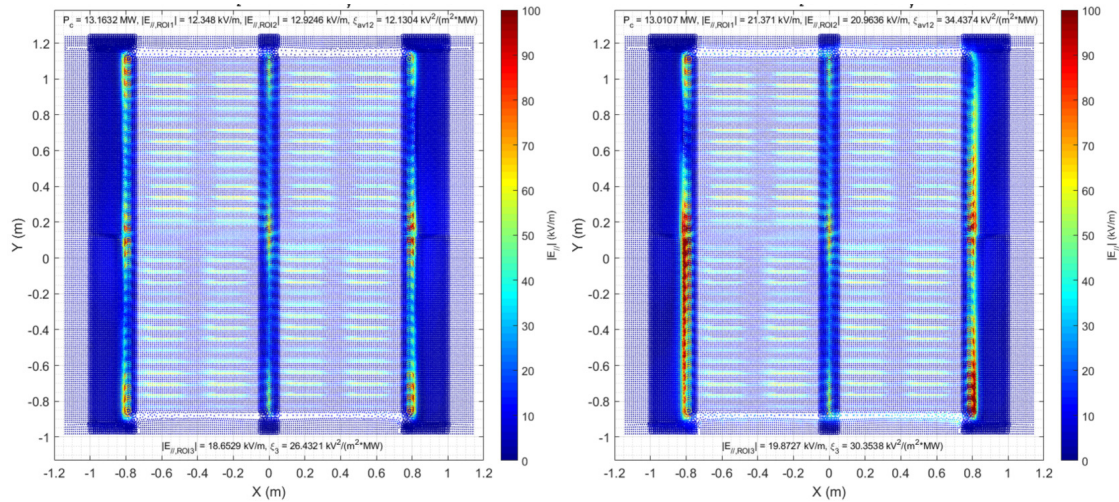

FIGURE 5. Electric field distribution in front of the antenna for the reference "CY10" geometry (left) and for the "CY12" launcher with grounding (right). The 2010 low density baseline scenario is loaded for both geometries at 47.5MHz. A peak voltage of 45kV is assumed in the circuit, with 0/90/180/270 toroidal phasing and 0-90 poloidal one. The average field magnitude is also reported for the left (ROI1) and right limiter (ROI2), as seen from the plasma side.

ACKNOWLEDGMENTS

This work has been conducted under contracts IO/20/CT/4300002118, IO/20/CT/4300002150 and IO/20/CT/4300002178. The views and opinions expressed herein do not necessarily reflect those of the ITER Organization. The authors would also like to thank A. Loarte, M. Schneider and F. Köchl for the generation of the profile and F. Calarco for supervising the ITER ICRF antennas.

REFERENCES

1. R. Agarwal and et al, "Status of the ITER Ion Cyclotron H&CD," in *Proceedings of the 22th Topical Conference on Radio-frequency Power in Plasma* (2017).
2. W. Tierens, "Assessments of the computational capabilities of COMSOL modelling," Tech. Rep. IO contract IO/20/CT/4300002150, Deliverable 8, ITER_D_3TKBZ8 v3.2 (IPP-Garching, 2022).
3. W. Tierens, "RAPLICASOL modelling of the ITER ICRF antenna," Tech. Rep. IO contract IO/20/CT/4300002150, Deliverable 9, ITER_D_3TKJKF v3.0 (IPP-Garching, 2022).
4. W. Tierens and et al., "ICRF code benchmarks for the ITER antenna; first non-axisymmetric cases," To be submitted to *Nuclear Fusion* (2022).
5. N. Bertelli, S. Shiraiwa, W. Helou, D. Milanesio, and W. Tierens, "Benchmark between antenna code TOPICA, RAPLICASOL and Petra-M for the ICRH ITER antenna," in *Proceedings of the 24th Topical Conference on Radio-frequency Power in Plasma* (2022).
6. V. Bobkov, R. Bilato, H. Faugel, O. Girka, W. Helou, P. Lamalle, V. Maquet, D. Milanesio, R. Ochoukov, V. Polli, W. Tierens, M. Usoltceva, and W. Zhang, "Multi-strap ICRF antenna modeling and development in support of ITER and EU-DEMO," in *Proceedings of the 24th Topical Conference on Radio-frequency Power in Plasma* (2022).
7. F. Louche, F. Durodie, W. Helou, A. Krivska, and D. Milanesio, "Modal analysis of the fields in the ITER ICRF antenna port plug cavity," in *Proceedings of the 24th Topical Conference on Radio-frequency Power in Plasma* (2022).
8. V. Lancellotti, D. Milanesio, R. Maggiore, G. Vecchi, and V. Kyrtsya, "TOPICA: an accurate and efficient numerical tool for analysis and design of ICRF antennas," *Nuclear Fusion* **46**, S476–S499 (2006).
9. D. Milanesio, O. Meneghini, V. Lancellotti, R. Maggiore, and G. Vecchi, "A multi-cavity approach for enhanced efficiency in TOPICA RF antenna code," *Nuclear Fusion* **49**, 115019 (2009).
10. M. Brambilla, "Modelling loop antennas for HF plasma heating in the ion cyclotron frequency range," *Plasma Physics and Controlled Fusion* **35**, 41–62 (1993).
11. W. Helou, "51.AN RF Design Report," Tech. Rep. ITER_D_44M4QS v2.1 (ITER Organization, 2022).
12. D. Milanesio and et al., Submitted to *Nuclear Fusion* (2022).
13. D. Milanesio and R. Maggiore, "ITER ICRF antenna analysis and optimization using the TOPICA code," *Nuclear Fusion* **50**, 025007 (2010).
14. A. Messiaen, R. Koch, R. Weynants, P. Dumortier, F. Louche, R. Maggiore, and D. Milanesio, "Performance of the ITER ICRH system as expected from TOPICA and ANTITER II modelling," *Nuclear Fusion* **50**, 025026 (2010).
15. P. Lamalle, "Reference plasmas for IC H&CD performance estimates," Tech. Rep. ITER_D_23G78Q v1.1 (ITER Organization, 2020).