

6 pi Josephson Effect in Majorana Box Devices

Original

6 pi Josephson Effect in Majorana Box Devices / Zazunov, A., Buccheri, F., Sodano, P., Egger, R.. - In: PHYSICAL REVIEW LETTERS. - ISSN 0031-9007. - 118:5(2017), p. 057001. [10.1103/PHYSREVLETT.118.057001]

Availability:

This version is available at: 11583/2981586 since: 2023-09-04T14:55:38Z

Publisher:

AIP - APS

Published

DOI:10.1103/PHYSREVLETT.118.057001

Terms of use:

This article is made available under terms and conditions as specified in the corresponding bibliographic description in the repository

Publisher copyright

APS postprint/Author's Accepted Manuscript e postprint versione editoriale/Version of Record

This article appeared in PHYSICAL REVIEW LETTERS, 2017, 118, 5, and may be found at <http://dx.doi.org/10.1103/PHYSREVLETT.118.057001>. Copyright 2017 American Physical Society

(Article begins on next page)

6π Josephson Effect in Majorana Box Devices

A. Zazunov,¹ F. Bucchieri,¹ P. Sodano,^{2,3} and R. Egger¹

¹*Institut für Theoretische Physik, Heinrich-Heine-Universität, D-40225 Düsseldorf, Germany*

²*International Institute of Physics, Universidade Federal do Rio Grande do Norte, 59012-970 Natal, Brazil*

³*INFN, Sezione di Perugia, Via Alessandro Pascoli, I-06123 Perugia, Italy*

(Received 21 November 2016; published 1 February 2017)

We study Majorana devices featuring a competition between superconductivity and multichannel Kondo physics. Our proposal extends previous work on single-channel Kondo systems to a topologically nontrivial setting of a non-Fermi liquid type, where topological superconductor wires (with gap Δ) represent leads tunnel coupled to a Coulomb-blockaded Majorana box. On the box, a spin degree of freedom with Kondo temperature T_K is nonlocally defined in terms of Majorana states. For $\Delta \gg T_K$, the destruction of Kondo screening by superconductivity implies a 4π -periodic Josephson current-phase relation. Using a strong-coupling analysis in the opposite regime $\Delta \ll T_K$, we find a 6π -periodic Josephson relation for three leads, with critical current $I_c \approx e\Delta^2/\hbar T_K$, corresponding to the transfer of fractionalized charges $e^* = 2e/3$.

DOI: 10.1103/PhysRevLett.118.057001

Introduction.—An important goal of condensed matter physics and quantum information science is to implement, thoroughly understand, and usefully employ systems hosting topologically protected Majorana bound states (MBSs) [1–3]. These states are expected near the ends of topological superconductor (TS) wires, and experimental evidence for MBSs has been reported for semiconductor-superconductor heterostructures with proximitized InAs or InSb nanowires [4–8]. For a Coulomb-blockaded superconducting island containing more than two MBSs (“Majorana box”), a spin operator is encoded by pairs of spatially separated MBSs. When normal leads are coupled to the MBSs, this spin is screened through cotunneling processes, culminating in the so-called topological Kondo effect (TKE) [9–21] which exhibits non-Fermi liquid physics below T_K . Unlike other overscreened multichannel Kondo systems [22–25], the TKE is intrinsically stable against anisotropies. Majorana devices could thus realize multichannel Kondo effects without delicate fine tuning of parameters.

Here we study the Josephson effect for a Majorana box with superconducting (instead of normal) leads as illustrated in Fig. 1. Previous theoretical work for Majorana systems contacted by superconducting electrodes has only addressed cases without TKE [26–30]. In our setup, a nontrivial competition between superconductivity and the Kondo effect arises because lead states below the superconducting gap Δ are not available anymore for screening the box spin. The simpler single-channel spin-1/2 Kondo case, which is of a Fermi-liquid type and can be realized when two superconducting leads are connected to a quantum dot [31], was studied in detail both theoretically [32–39] and experimentally [40–45]. It has been established that a local quantum phase transition at $\Delta/T_K \approx 1$

separates a so-called 0 phase (small Δ/T_K) and a π phase (large Δ/T_K), where essentially the entire crossover is described by universal scaling functions of Δ/T_K . Deep in the 0 phase, the Kondo resonance persists and yields the current-phase relation of a fully transparent superconducting junction; while in the π phase, the Kondo effect is almost completely quenched and one finds a negative supercurrent.

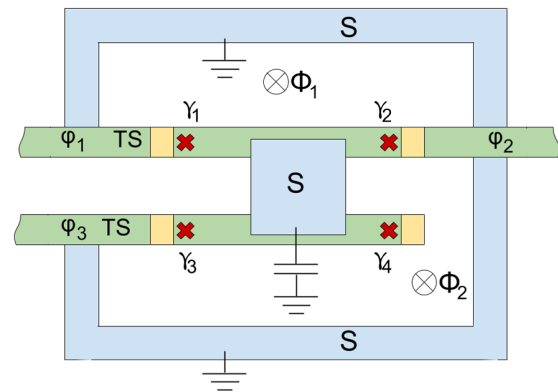

FIG. 1. Schematic device setup with $M = 3$ superconducting leads, using two long parallel InAs (or InSb) nanowires. Proximitized parts give TS wire regions (green) with Majorana end states (red crosses, shown only on the parts forming the Majorana box). Short nonproximitized sections (yellow) are used as gate-tunable tunnel contacts. The floating Majorana box with four MBSs (γ_j) is created by joining the two central TS parts through an s -wave superconducting bridge (blue). Superconducting leads are obtained from outer TS wire sections in contact with conventional superconductors (blue). By tuning magnetic fluxes ($\Phi_{1,2}$), the supercurrents I_j can be studied as function of the phases (ϕ_1, ϕ_2, ϕ_3).

With the Majorana device proposed below, the rich interplay between superconductivity and multichannel Kondo screening may also become experimentally accessible. The symmetry group of the TKE is affected here, by even a tiny gap Δ , due to the proliferation of crossed Andreev reflection processes. For $\Delta \ll T_K$ and $M = 3$ attached leads, our nonperturbative strong-coupling theory predicts that two-channel Kondo physics is responsible for a 6π -periodic Josephson effect with critical current $I_c \approx e\Delta^2/\hbar T_K$. This periodicity implies charge fractionalization in units of $e^* = 2e/3$ for elementary transfer processes. On the other hand, for $\Delta \gg T_K$, we recover the well-known 4π -periodic current-phase relation of parity-conserving topological Josephson junctions [1–3]. In view of the rapid experimental progress on Majorana states in semiconductor-superconductor devices [4–8], our predictions can likely be tested soon, e.g., by the techniques recently employed to observe the 4π Josephson effect [46].

Model.—The superconducting leads attached to the Majorana box are described as semi-infinite TS wires of symmetry class D . For M leads, the effectively spinless low-energy Hamiltonian is (we put $e = \hbar = v_F = 1$) [1]

$$H_{\text{leads}} = \sum_{j=1}^M \int_0^\infty dx \Psi_j^\dagger(x) [-i\partial_x \sigma_z + \Delta_j e^{-i\varphi_j \sigma_z} \sigma_y] \Psi_j(x), \quad (1)$$

where Δ_j denotes the absolute value and φ_j the phase of the respective proximity-induced superconducting gap, Pauli matrices $\sigma_{x,y,z}$ and unity σ_0 act in Nambu space, and the spinors $\Psi_j = (\psi_{j,R}, \psi_{j,L}^\dagger)^T$ are expressed in terms of right- and left-moving fermion operators with boundary condition $\psi_{j,R}(0) = \psi_{j,L}(0)$. We mainly discuss results for identical gaps, $\Delta_j = \Delta$, but our theory applies to the general case [47]. The reason why we did not assume conventional s -wave superconductors as leads is that different pairing symmetries for the box and the leads imply a supercurrent blockade [26], where only above-gap quasiparticle transport is possible under rather general conditions [27–30]. Fortunately, leads with effective p -wave pairing symmetry may be implemented in a natural way, see below and Fig. 1. At $x = 0$, each lead fermion ψ_j is then coupled by a tunnel amplitude t_j to the respective Majorana operator $\gamma_j = \gamma_j^\dagger$ on the box, with an anticommutator $\{\gamma_j, \gamma_k\} = \delta_{jk}$. We study energy scales well below the proximity gap Δ_{box} on the box, where Δ_{box} and $\Delta \lesssim \Delta_{\text{box}}$ are taken as independent parameters and above-gap quasiparticles on the box are neglected. For a large charging energy E_C , charge quantization implies a parity constraint for the Majorana states on the box and tends to suppress quasiparticle poisoning processes. Nonetheless, the ground state remains degenerate for $M > 2$, where the Majorana bilinears $i\gamma_j\gamma_k$ represent the box spin [9,15]. The projection to the Hilbert space sector with quantized box charge yields [9]

$$H_{\text{EC}} = \sum_{j \neq k}^M \lambda_{jk} \Psi_j^\dagger(0) \Psi_k(0) \gamma_k \gamma_j, \quad (2)$$

where the dimensionless exchange couplings $\lambda_{jk} = 2t_j t_k^*/E_C$ describe elastic cotunneling between leads $j \leftrightarrow k$. For $\Delta = 0$, Refs. [9–11] show that $H_{\text{leads}} + H_{\text{EC}}$ gives a TKE of $\text{SO}_2(M)$ symmetry with

$$T_K = E_C e^{-\pi/[2(M-2)\bar{\lambda}]}, \quad \bar{\lambda} = \frac{1}{M(M-1)} \sum_{j \neq k} \lambda_{jk}, \quad (3)$$

where the group relation $\text{SO}_2(3) \sim \text{SU}_4(2)$ implies a four-channel Kondo effect for $M = 3$ [49]. For $\Delta \neq 0$, the competition between Kondo physics and superconductivity is then controlled by the ratio Δ/T_K . For $\varphi_j = 0$, the above model also describes junctions of off-critical anisotropic spin chains [12,13,20,21].

Implementation.—Before turning to results, we briefly discuss how to realize this model for the simplest nontrivial case $M = 3$, cf. Fig. 1. The floating box is defined by connecting two parallel TS wires by an s -wave superconductor. Nanowires can be fabricated with an epitaxial superconducting shell [5], where a magnetic field simultaneously drives both wires into the TS phase [1]. We assume that the TS sections on the box are so long that overlap between different Majorana states is negligible. Nonproximitized wire parts yield gate-tunable tunnel barriers, and leads are defined by the outer TS wires in Fig. 1. Using available Majorana wires [7], it appears possible to realize the Kondo regime [9,14,15,50]. In a loop geometry with magnetic fluxes [51], one can change the phase differences between TS leads and measure the current-phase relation.

Josephson current.—It is often convenient to integrate out the lead fermion modes away from $x = 0$. The Euclidean action, $S = S_{\text{leads}} + S_{\text{box}} + S_{\text{EC}}$, is thereby expressed in terms of Majorana fields $\gamma_j(\tau)$ and boundary ($x = 0$) Grassmann-Nambu spinor fields, $\Psi_j(\tau) = (\psi_j, \bar{\psi}_j)^T$. With inverse temperature β , H_{leads} gives

$$S_{\text{leads}} = -\frac{1}{2} \int_0^\beta d\tau d\tau' \sum_j \bar{\Psi}_j(\tau) G_j^{-1}(\tau - \tau') \Psi_j(\tau'), \quad (4)$$

where the boundary Green's function $G_j(\tau)$ has the Fourier transform [29]

$$G_j(\omega) = -i \text{sgn}(\omega) \sqrt{1 + \frac{\Delta_j^2}{\omega^2} \sigma_0 + \frac{\Delta_j e^{-i\varphi_j \sigma_z}}{i\omega} \sigma_x}. \quad (5)$$

The box action is $S_{\text{box}} = \frac{1}{2} \int d\tau \sum_j \gamma_j \partial_\tau \gamma_j$, and $S_{\text{EC}} = \int d\tau H_{\text{EC}}(\tau)$. Expressing the partition function as a functional integral, $Z = e^{-\beta F} = \int \mathcal{D}(\Psi_j, \gamma_j) e^{-S}$, the supercurrent I_j through lead number j (oriented towards the box) follows as phase derivative of the free energy,

$I_j = (2e/\hbar)\partial_{\varphi_j}F$, where current conservation implies $\sum_j I_j = 0$. We discuss the zero-temperature limit in what follows.

Atomic limit: $\Delta \gg T_K$.—In the atomic limit, after gauging out the φ_j phases from the bulk, Eq. (5) simplifies to $G_j(\omega) \simeq [\Delta_j/(i\omega)](\sigma_0 + \sigma_x)$. As a consequence, the lead action (4) becomes $S_{\text{leads}} \simeq \frac{1}{2}\sum_j \int d\tau \eta_j \partial_\tau \eta_j$, where the boundary fermions define zero-energy Majorana operators, $\eta_j = (\psi_j + \psi_j^\dagger)/\sqrt{2\Delta_j}$, and Eq. (2) yields the effective low-energy Hamiltonian $H_{\text{eff}} = \frac{1}{2}\sum_{j \neq k} \sqrt{\Delta_j \Delta_k} \times \lambda_{jk} e^{i(\varphi_j - \varphi_k)/2} \eta_j \eta_k \gamma_k \gamma_j$. Since all mutually commuting products $2i\eta_j \gamma_j = \sigma_j = \pm 1$ are conserved, we arrive at the 4π -periodic supercurrents

$$I_j = \frac{e\Delta}{\hbar} \sum_{k \neq j} \lambda_{jk} \sigma_j \sigma_k \sin\left(\frac{\varphi_j - \varphi_k}{2}\right), \quad (6)$$

where the $\{\sigma_j\}$ correspond to different fermion parity sectors and we put $\Delta_j = \Delta$. The Kondo effect is suppressed in the atomic limit since no low-energy quasiparticles in the leads are available to screen the box spin. In fact, Eq. (6) also describes topological Josephson junctions with featureless tunnel contacts [1].

Renormalization group (RG) analysis.—To tackle the case of arbitrary Δ/T_K , we start with the one-loop RG equations. Renormalizations appear for Δ , for the λ_{jk} , and for the complex-valued crossed Andreev reflection amplitudes $\kappa_{jk} = \kappa_{kj}$ (with $j \neq k$). Such couplings are absent in the bare model but will be generated during the RG flow by an interplay of exchange processes (λ) and superconductivity (Δ). They describe the creation (or annihilation) of two fermions in different leads by splitting (or forming) a Cooper pair on another lead, corresponding to the additional term

$$H_{\text{CAR}} = \sum_{j < k} \kappa_{jk} \psi_j^\dagger(0) \psi_k^\dagger(0) \gamma_k \gamma_j + \text{H.c.} \quad (7)$$

In the Supplemental Material [47], we provide a derivation of the RG equations for arbitrary $\Delta_j \ll D$, where the bandwidth is $D \simeq \min(E_C, \Delta_{\text{box}})$. For $\Delta_j = \Delta$, taking a gauge where the phase dependence only appears in $H_{\text{EC}} + H_{\text{CAR}}$, we obtain ($j \neq k$)

$$\begin{aligned} \frac{d\lambda_{jk}}{d\ell} &= \frac{2}{\pi} \sum_{m \neq (j,k)}^M [\sqrt{1 + \delta^2} (\lambda_{jm} \lambda_{mk} + \kappa_{jm} \kappa_{mk}^*) \\ &\quad + \delta (\lambda_{jm} \kappa_{mk}^* + \kappa_{jm} \lambda_{mk})], \\ \frac{d\kappa_{jk}}{d\ell} &= \frac{2}{\pi} \sum_{m \neq (j,k)}^M [\delta (\lambda_{jm} \lambda_{mk}^* + \kappa_{jm} \kappa_{mk}) \\ &\quad + \sqrt{1 + \delta^2} (\lambda_{jm} \kappa_{mk} + \kappa_{jm} \lambda_{mk}^*)], \end{aligned} \quad (8)$$

with $\delta(\ell) = e^\ell \Delta/D$ and initial conditions $\kappa_{jk}(0) = 0$ and $\lambda_{jk}(0) = (2t_{jk}^*/E_C) e^{i(\varphi_j - \varphi_k)/2}$. The RG flow thus only depends on the gauge-invariant phase differences $\varphi_j - \varphi_k$.

RG solution for the unbiased case.—Putting all $\varphi_j = 0$, the above RG equations can be solved analytically. The matrices $\Lambda_{jk}^{(\pm)} = \lambda_{jk} \pm \kappa_{jk}$ may now be chosen real symmetric and obey decoupled flow equations,

$$\frac{d\Lambda_{jk}^{(\pm)}}{d\ell} = \frac{2}{\pi} (\sqrt{1 + \delta^2} \pm \delta) \sum_{m \neq (j,k)}^M \Lambda_{jm}^{(\pm)} \Lambda_{mk}^{(\pm)}, \quad (9)$$

which (up to a rescaling) coincide with those for the TKE. The results of Refs. [9–11, 14] imply that anisotropies in the $\Lambda_{jk}^{(\pm)}$ are irrelevant perturbations, and both matrices scale towards isotropy, $\Lambda_{jk}^{(\pm)}(\ell) \rightarrow \Lambda_{\pm}(\ell)[1 - \delta_{jk}]$. For an isotropic initial condition, $\Lambda_{\pm}(0) = \bar{\lambda}$, with the average coupling $\bar{\lambda}$ in Eq. (3), we find from Eq. (9)

$$\Lambda_{\pm}(\ell) = \lambda(\ell) \pm \kappa(\ell) = \frac{\bar{\lambda}}{1 - \frac{2(M-2)\bar{\lambda}}{\pi} \mathcal{F}_{\pm}(\ell)}, \quad (10)$$

with the monotonically increasing functions

$$\mathcal{F}_{\pm}(\ell) = \left(\sqrt{1 + \delta^2} + \ln \sqrt{\frac{\sqrt{1 + \delta^2} - 1}{\sqrt{1 + \delta^2} + 1}} \pm \delta \right)_{\delta(0)}^{\delta(\ell)}. \quad (11)$$

Hence $\Lambda_{\pm}(\ell)$ as well as $\delta(\ell)$ scale towards strong coupling (with $\Lambda_+ > \Lambda_-$). For $\Delta \ll T_K$ with T_K in Eq. (3), the energy scales T_{\pm} where $\Lambda_{\pm}(\ell)$ enters the strong-coupling regime can be estimated as $T_{\pm} \simeq T_K e^{\pm\{\pi\Delta/[2(M-2)\bar{\lambda}E_C]\}}$. The renormalized couplings $\lambda \gtrsim \kappa$ are then of order unity when reaching the strong-coupling regime. Now any finite coupling κ (as well as Δ) is expected to destabilize the $\text{SO}_2(M)$ Kondo fixed point and to induce a flow to a stable fixed point with symmetry group $\text{SO}_1(M)$. For $M = 3$, this has been shown in Ref. [20], where the relation $\text{SO}_1(3) \sim \text{SU}_2(2)$ implies a two-channel (instead of the $\Delta = 0$ four-channel [9, 49]) Kondo fixed point. On the other hand, for $\Delta \gg T_K$, the pairing variable $\delta(\ell)$ reaches the strong-coupling regime first and we are back to the atomic limit. In the remainder, we discuss the limit $\Delta \ll T_K$ for $M = 3$ leads.

Phase-biased case.—For $\varphi_j \neq 0$, the RG equations (8) are more difficult to solve. Numerical analysis of Eq. (8) shows that for $\Delta \ll T_K$, the absolute values of the couplings λ_{jk} and κ_{jk} again flow towards isotropy but with a specific phase dependence. With the real positive couplings $\lambda(\ell)$ and $\kappa(\ell)$ in Eq. (10), we find $\lambda_{jk}(\ell) \rightarrow \lambda(\ell) e^{i(\varphi_j - \varphi_k)/2}$ and $\kappa_{jk}(\ell) \rightarrow \kappa(\ell) e^{i\theta_{jk}}$ as one approaches the strong-coupling regime, where $\theta_{jk} = (\varphi_j + \varphi_k)/2 - \varphi_0$ with the center-of-mass phase $\varphi_0 = (\varphi_1 + \varphi_2 + \varphi_3)/3$. This result for θ_{jk} follows directly from gauge invariance and a stationarity condition [47]. Finally, in what follows,

it is convenient to remove the phase factors from $H_{\text{EC}} + H_{\text{CAR}}$ by the gauge transformation $\psi_{j,R/L}(x) \rightarrow e^{i(\varphi_j - \varphi_0)/2} \psi_{j,R/L}(x)$.

Strong-coupling analysis for $M = 3$ and $\Delta \ll T_K$.—We now turn to the asymptotic low-energy regime which can be accessed by perturbation theory around the two-channel Kondo fixed point [16,52,53]. We first introduce chiral fermion fields for the TS leads by an unfolding transformation, $\Phi_j(x > 0) = \psi_{j,R}(x)$ and $\Phi_j(x < 0) = \psi_{j,L}(-x)$, and switch to their Majorana representations, $\Phi_j(x) = [\eta_j(x) + i\xi_j(x)]/\sqrt{2}$. Using the renormalized couplings $\Lambda_{\pm} = \lambda \pm \kappa$ in Eq. (10) with $\Lambda_+ \gg \Lambda_-$, we then obtain

$$H_{\text{EC}} + H_{\text{CAR}} = \Lambda_+ \mathbf{S} \cdot \mathbf{S}_\eta + \Lambda_- \mathbf{S} \cdot \mathbf{S}_\xi, \quad (12)$$

where we define the spin-1/2 operators $\mathbf{S} = -(i/2)\boldsymbol{\gamma} \times \boldsymbol{\gamma}$, $\mathbf{S}_\eta = -(i/2)\boldsymbol{\eta}(0) \times \boldsymbol{\eta}(0)$, and $\mathbf{S}_\xi = -(i/2)\boldsymbol{\xi}(0) \times \boldsymbol{\xi}(0)$, with $\boldsymbol{\gamma} = (\gamma_1, \gamma_2, \gamma_3)^T$ and similarly for the $\boldsymbol{\eta}$ and $\boldsymbol{\xi}$ Majorana triplets. The theory for $\Delta = \Lambda_- = 0$ then describes the two-channel Kondo problem. The strong-coupling regime is accessible by employing the following rules [16,52,53]: (i) Screening processes leading to a singlet state between \mathbf{S} and \mathbf{S}_η imply the replacement $\mathbf{S} \rightarrow iT_K^{-1/2} \gamma_0 \boldsymbol{\eta}(0)$, where the Majorana operator γ_0 describes the residual unscreened spin. With time ordering \mathcal{T} , we have $\langle \mathcal{T} \gamma_0(\tau) \gamma_0(0) \rangle = \frac{1}{2} \text{sgn}(\tau)$. (ii) The Majorana triplet $\boldsymbol{\eta}(x)$ obeys twisted boundary conditions, $\boldsymbol{\eta}(x) \rightarrow \text{sgn}(x)\boldsymbol{\eta}(x)$, while the $\boldsymbol{\xi}$ triplet remains unchanged. In terms of fermions, this implies perfect Andreev reflection, $\psi_{j,R}(0) = -\psi_{j,L}^\dagger(0)$. (iii) For $\Delta = \Lambda_- = 0$, the leading irrelevant operator is given by $H_{\text{LIO}} = 2\pi T_K^{-1/2} \gamma_0 \eta_1(0) \eta_2(0) \eta_3(0)$, with scaling dimension $d = 3/2$. The perturbation H_- due to Λ_- , see Eq. (12), is then also irrelevant with $d = 3/2$.

We now have to include the bulk pairing term $\propto \Delta$ in the leads in a nonperturbative manner. In fact, the leading contribution to I_j follows from second-order perturbation theory in $H' = H_{\text{LIO}} + H_-$. Since H' has scaling dimension $d = 3/2$, one naively expects a linear temperature (T) dependence of I_j . However, Δ is RG-relevant and provides a $1/T$ factor, resulting in a finite supercurrent at $T = 0$. We then need the boundary Green's functions for the field combinations $[\psi_{j,R}(0) - \psi_{j,L}^\dagger(0)]/\sqrt{2}$ representing decoupled TS leads with twisted boundary conditions. Following the steps in Ref. [29], we thereby obtain the lead Majorana correlation functions at the boundary ($x = 0^+$),

$$\begin{aligned} \langle \mathcal{T} \eta_j(\tau) \xi_k(0) \rangle &= -i\delta_{jk} \Delta \cos(\varphi_j - \varphi_0) f(\tau), \\ \langle \mathcal{T} \eta_j(\tau) \eta_k(0) \rangle &= \langle \mathcal{T} \xi_j(\tau) \xi_k(0) \rangle = -\delta_{jk} \partial_\tau f(\tau), \\ f(\tau) &= \int \frac{d\omega}{2\pi} \frac{1 - e^{-\sqrt{\omega^2 + \Delta^2}/T_K}}{\sqrt{\omega^2 + \Delta^2}} \cos(\omega\tau). \end{aligned} \quad (13)$$

The $T = 0$ supercurrents I_j then come from the second-order contribution to the free energy, $F^{(2)} = -\frac{1}{2} \int d\tau \langle \mathcal{T} H'(\tau) H'(0) \rangle$. Using Eq. (13) and Wick's theorem [47], the phase derivatives of $F^{(2)}$ yield

$$I_j(\varphi_1, \varphi_2, \varphi_3) = I_0 \sum_{k \neq j}^3 \left[\sin(\varphi_j - \varphi_k) + \frac{1}{3} \sin\left(\frac{\varphi_j + \varphi_k - 2\varphi_p}{3}\right) - \frac{1}{3} \sin\left(\frac{\varphi_k + \varphi_p - 2\varphi_j}{3}\right) \right], \quad (14)$$

where $p \neq (j, k)$. The current scale, and thus ultimately the critical current I_c , is set by

$$I_0 = \zeta \frac{\Delta}{T_K} \frac{e\Delta}{\hbar}, \quad \zeta = \frac{\Lambda_-(\Lambda_- - 2\pi)}{3} f^3(0). \quad (15)$$

The dimensionless number ζ is of order unity and can be positive or negative. Compared to the conventional Kondo system with critical current $I_c = e\Delta/\hbar$ [32], there is a suppression factor $\Delta/T_K \ll 1$ due to the residual unscreened spin encoded by γ_0 . Equation (14) obeys current conservation, $\sum_j I_j = 0$, and predicts a 6π -periodic phase dependence which in turn implies charge fractionalization in units of $e^* = 2e/3$ for charge transfer between TS leads. For finite Δ , we have a two-channel instead of a four-channel Kondo problem, and hence this value of e^* differs from the one for normal leads probed by shot noise [14,50]. The 6π periodicity is due to the non-Fermi liquid nature of the two-channel Kondo fixed point and can be seen explicitly by putting $(\varphi_1, \varphi_2, \varphi_3) = (\varphi, \varphi, 0)$, where Eq. (14) gives $I_{1,2}/I_0 = \sin\varphi + [\sin(\varphi/3) + \sin(2\varphi/3)]/3$. On the other hand, for $(\varphi_1, \varphi_2, \varphi_3) = (\varphi/2, -\varphi/2, 0)$, one gets a 4π periodicity, $I_{1,2}/I_0 = \pm[\sin(\varphi) + 2\sin(\varphi/2)]$, since the third terminal is now basically decoupled ($I_3 = 0$). In general, the 6π periodicity coexists with 2π and 4π effects. Finally, we note that for an observation of the 6π Josephson effect, one should probe the supercurrent at finite frequencies, cf. Ref. [46].

Conclusions.—We have studied the Josephson effect through a multichannel Kondo impurity. This problem could be realized using a Majorana box device with superconducting leads. The different periodicities in the atomic and the strong-coupling limit (4π vs 6π for three leads) could indicate a quantum phase transition at $\Delta \approx T_K$. This point requires a detailed numerical study which can also clarify to what extent the crossover is universal in Δ/T_K . It would also be interesting to study topologically trivial p -wave superconductors as leads, and to generalize our strong-coupling analysis to $M > 3$ where one may encounter even higher periodicities in the current-phase relation.

We thank C. Mora for discussions. We acknowledge funding by the Deutsche Forschungsgemeinschaft (Bonn) with the network CRC TR 183 (Project No. C04), by the Brazilian CNPq SwB Program and from MEC-UFRN.

-
- [1] J. Alicea, *Rep. Prog. Phys.* **75**, 076501 (2012).
- [2] M. Leijnse and K. Flensberg, *Semicond. Sci. Technol.* **27**, 124003 (2012).
- [3] C. W. J. Beenakker, *Annu. Rev. Condens. Matter Phys.* **4**, 113 (2013).
- [4] V. Mourik, K. Zuo, S. M. Frolov, S. R. Plissard, E. P. A. Bakkers, and L. P. Kouwenhoven, *Science* **336**, 1003 (2012).
- [5] P. Krogstrup, N. L. B. Ziino, W. Chang, S. M. Albrecht, M. H. Madsen, E. Johnson, J. Nygård, C. M. Marcus, and T. S. Jespersen, *Nat. Mater.* **14**, 400 (2015).
- [6] A. P. Higginbotham, S. M. Albrecht, G. Kirsanskas, W. Chang, F. Kuemmeth, T. S. Jespersen, J. Nygård, K. Flensberg, and C. M. Marcus, *Nat. Phys.* **11**, 1017 (2015).
- [7] S. M. Albrecht, A. P. Higginbotham, M. Madsen, F. Kuemmeth, T. S. Jespersen, J. Nygård, P. Krogstrup, and C. M. Marcus, *Nature (London)* **531**, 206 (2016).
- [8] H. Zhang *et al.*, arXiv:1603.04069.
- [9] B. Béri and N. R. Cooper, *Phys. Rev. Lett.* **109**, 156803 (2012).
- [10] A. Altland and R. Egger, *Phys. Rev. Lett.* **110**, 196401 (2013).
- [11] B. Béri, *Phys. Rev. Lett.* **110**, 216803 (2013).
- [12] N. Crampé and A. Trombettoni, *Nucl. Phys.* **B871**, 526 (2013).
- [13] A. M. Tselik, *Phys. Rev. Lett.* **110**, 147202 (2013).
- [14] A. Zazunov, A. Altland, and R. Egger, *New J. Phys.* **16**, 015010 (2014).
- [15] A. Altland, B. Béri, R. Egger, and A. M. Tselik, *Phys. Rev. Lett.* **113**, 076401 (2014).
- [16] E. Eriksson, C. Mora, A. Zazunov, and R. Egger, *Phys. Rev. Lett.* **113**, 076404 (2014).
- [17] M. R. Galpin, A. K. Mitchell, J. Temaismithi, D. E. Logan, B. Béri, and N. R. Cooper, *Phys. Rev. B* **89**, 045143 (2014).
- [18] F. Buccheri, H. Babujian, V. E. Korepin, P. Sodano, and A. Trombettoni, *Nucl. Phys.* **B896**, 52 (2015).
- [19] F. Buccheri, G. D. Bruce, A. Trombettoni, D. Cassettari, H. Babujian, V. E. Korepin, and P. Sodano, *New J. Phys.* **18**, 075012 (2016).
- [20] D. Giuliano, P. Sodano, A. Tagliacozzo, and A. Trombettoni, *Nucl. Phys.* **B909**, 135 (2016).
- [21] D. Giuliano, G. Campagnano, and A. Tagliacozzo, *Eur. Phys. J. B* **89**, 251 (2016).
- [22] A. O. Gogolin, A. A. Nersesyan, and A. M. Tselik, *Bosonization and Strongly Correlated Systems* (Cambridge University Press, Cambridge, England, 1998).
- [23] R. M. Potok, I. G. Rau, H. Shtrikman, Y. Oreg, and D. Goldhaber-Gordon, *Nature (London)* **446**, 167 (2007).
- [24] Z. Iftikhar, S. Jezouin, A. Anthore, U. Gennser, F. D. Parmentier, A. Cavanna, and F. Pierre, *Nature (London)* **526**, 233 (2015).
- [25] A. J. Keller, L. Peeters, C. P. Moca, I. Weymann, D. Mahalu, V. Umansky, G. Zarand, and D. Goldhaber-Gordon, *Nature (London)* **526**, 237 (2015).
- [26] A. Zazunov and R. Egger, *Phys. Rev. B* **85**, 104514 (2012).
- [27] Y. Peng, F. Pientka, Y. Vinkler-Aviv, L. I. Glazman, and F. von Oppen, *Phys. Rev. Lett.* **115**, 266804 (2015).
- [28] P. A. Iosevich, P. M. Ostrovsky, and M. V. Feigel'man, *Phys. Rev. B* **93**, 125435 (2016).
- [29] A. Zazunov, R. Egger, and A. Levy Yeyati, *Phys. Rev. B* **94**, 014502 (2016).
- [30] F. Setiawan, W. S. Cole, J. D. Sau, and S. Das Sarma, *Phys. Rev. B* **95**, 020501 (2017).
- [31] A. Martín-Rodero and A. Levy Yeyati, *Adv. Phys.* **60**, 899 (2011).
- [32] L. I. Glazman and K. A. Matveev, *Pis'ma Zh. Eksp. Teor. Fiz.* **49**, 570 (1989) [*JETP Lett.* **49**, 659 (1989)].
- [33] A. Golub, *Phys. Rev. B* **54**, 3640 (1996).
- [34] A. V. Rozhkov and D. P. Arovas, *Phys. Rev. Lett.* **82**, 2788 (1999).
- [35] E. Vecino, A. Martín-Rodero, and A. Levy Yeyati, *Phys. Rev. B* **68**, 035105 (2003).
- [36] F. Siano and R. Egger, *Phys. Rev. Lett.* **93**, 047002 (2004).
- [37] M. S. Choi, M. Lee, K. Kang, and W. Belzig, *Phys. Rev. B* **70**, 020502 (2004).
- [38] C. Karrasch, A. Oguri, and V. Meden, *Phys. Rev. B* **77**, 024517 (2008).
- [39] D. J. Luitz, F. F. Assaad, T. Novotný, C. Karrasch, and V. Meden, *Phys. Rev. Lett.* **108**, 227001 (2012).
- [40] A. Y. Kasumov, R. Deblock, M. Kociak, B. Reulet, H. Bouchiat, I. I. Khodos, Y. B. Gorbatov, V. T. Volkov, C. Journet, and M. Burghard, *Science* **284**, 1508 (1999).
- [41] J. A. van Dam, Y. V. Nazarov, E. P. A. M. Bakkers, S. De Franceschi, and L. P. Kouwenhoven, *Nature (London)* **442**, 667 (2006).
- [42] J. P. Cleuziou, W. Wernsdorfer, V. Bouchiat, T. Ondarcuhu, and M. Monthieux, *Nat. Nanotechnol.* **1**, 53 (2006).
- [43] H. Ingerslev Jørgensen, T. Novotný, K. Grove-Rasmussen, K. Flensberg, and P. E. Lindelof, *Nano Lett.* **7**, 2441 (2007).
- [44] A. Eichler, R. Deblock, M. Weiss, C. Karrasch, V. Meden, C. Schönenberger, and H. Bouchiat, *Phys. Rev. B* **79**, 161407 (2009).
- [45] R. Delagrangé, D. J. Luitz, R. Weil, A. Kasumov, V. Meden, H. Bouchiat, and R. Deblock, *Phys. Rev. B* **91**, 241401 (2015).
- [46] E. Bocquillon, R. S. Deacon, J. Wiedenmann, P. Leubner, T. M. Klapwijk, C. Brüne, K. Ishibashi, H. Buhmann, and L. W. Molenkamp, *Nat. Nanotechnol.*, doi:10.1038/nnano.2016.159 (2016).
- [47] See Supplemental Material at <http://link.aps.org/supplemental/10.1103/PhysRevLett.118.057001> for additional details and derivations, which includes Ref. [48].
- [48] J. Cardy, *Scaling and Renormalization in Statistical Physics* (Cambridge University Press, Cambridge, UK, 1996).
- [49] M. Fabrizio and A. O. Gogolin, *Phys. Rev. B* **50**, 17732(R) (1994).
- [50] B. Béri, arXiv:1610.03064.
- [51] E. Strambini, S. D'Ambrosio, F. Vischi, F. S. Bergeret, Yu. V. Nazarov, and F. Giazotto, *Nat. Nanotechnol.* **11**, 1055 (2016).
- [52] I. Affleck and A. W. W. Ludwig, *Phys. Rev. B* **48**, 7297 (1993).
- [53] P. Coleman, L. B. Ioffe, and A. M. Tselik, *Phys. Rev. B* **52**, 6611 (1995).