

Gallium Nitride Power Devices in Power Electronics Applications: State of Art and Perspectives

*Original*

Gallium Nitride Power Devices in Power Electronics Applications: State of Art and Perspectives / Musumeci, S., Barba, V.. - In: ENERGIES. - ISSN 1996-1073. - 16:9(2023). [10.3390/en16093894]

*Availability:*

This version is available at: 11583/2980035 since: 2023-07-07T12:24:12Z

*Publisher:*

MDPI

*Published*

DOI:10.3390/en16093894

*Terms of use:*

This article is made available under terms and conditions as specified in the corresponding bibliographic description in the repository

*Publisher copyright*

(Article begins on next page)

Perspective

# Gallium Nitride Power Devices in Power Electronics Applications: State of Art and Perspectives

Salvatore Musumeci <sup>\*</sup>  and Vincenzo Barba

Dipartimento Energia “Galileo Ferraris”, Politecnico di Torino, 10129 Torino, Italy; vincenzo.barba@polito.it

\* Correspondence: salvatore.musumeci@polito.it

**Abstract:** High-electron-mobility transistors based on gallium nitride technology are the most recently developed power electronics devices involved in power electronics applications. This article critically overviews the advantages and drawbacks of these enhanced, wide-bandgap devices compared with the silicon and silicon carbide MOSFETs used in power converters. High-voltage and low-voltage device applications are discussed to indicate the most suitable area of use for these innovative power switches and to provide perspective for the future. A general survey on the applications of gallium nitride technology in DC-DC and DC-AC converters is carried out, considering the improvements and the issues expected for the higher switching transient speed achievable.

**Keywords:** GaN FET; HEMT; enhancement mode; depletion mode; WBG; SiC MOSFET; super-junction MOSFET; cascode; LIDAR

## 1. Introduction

Wide-bandgap materials have begun to replace silicon in several power electronics applications. At present, gallium nitride (GaN) is probably the most challenging technology in the field of power electronics, allowing for the development of attractive devices with increased power density, reduced on resistance, and very-high-frequency switching. The wide bandgap of the semiconductor material results in a high critical electric field, which can lead to designs of electronic devices with a shorter drift region and therefore a lower on-state resistance when compared to a silicon-based device featuring the same voltage rating [1]. Due to the high switching speed, GaN power electronic devices require a careful design of the power loop layout in converter applications [2]. Furthermore, appropriate packaging is necessary to both reduce the stray inductances and to dissipate the heat due to the device’s high energy density. The substantial reduction in chip size compared to silicon power devices with the same current and voltage rate and the high switching frequency that is currently attainable (up to tens of MHz) [3] allows for a decrease in the power converter’s global volume. The reduction in the power converter size is a key point for the integration of converters and actuators such as integrated modular motor drives (IMMDs) [4]. Furthermore, the reduction in switching power losses provides increasingly efficient solutions for converter applications featuring emerging opportunities for the expanding power electronics markets. There are several fields of power electronics applications benefiting from the technological advancements of GaN devices, especially in the low-voltage (<200 V) power supply areas, which are, at present, having a growing impact on modern society, such as in telecom/datacom, server SMPS, and wireless charging. Furthermore, it also is an enabling technology for the integration of renewable energy with power converters, electric vehicles, industrial automation, and modular battery management systems (BMSs) [5], generally at a higher voltage rate (currently, 650 V is the standard for high-voltage GaN, with some power device fabrications achieving a maximum voltage of up to 1200 V). The wide-bandgap semiconductors in all mentioned applications improve the power converters’ features, reducing their weight, volume, and lifecycle cost [6]. Furthermore, the increasing



**Citation:** Musumeci, S.; Barba, V. Gallium Nitride Power Devices in Power Electronics Applications: State of Art and Perspectives. *Energies* **2023**, *16*, 3894. <https://doi.org/10.3390/en16093894>

Academic Editor: K. T. Chau

Received: 13 April 2023

Revised: 28 April 2023

Accepted: 3 May 2023

Published: 4 May 2023



**Copyright:** © 2023 by the authors. Licensee MDPI, Basel, Switzerland. This article is an open access article distributed under the terms and conditions of the Creative Commons Attribution (CC BY) license (<https://creativecommons.org/licenses/by/4.0/>).

demand for compact and long, autonomous, battery-powered portable devices has led to the proposal of GaN technology as a possible attractive response for near-future applications. In China, which has a very representative global market index, consumer electronics applications are projected to grow from USD 79.6 million in 2021 to USD 964.7 million in 2027 in the power GaN device market (source: Power GaN report, Yole intelligence 2023). Figure 1 describes the evolution of the penetration of GaN devices into the market of power electronics, highlighting their applications [7]. Currently, cost is one of the significant limits, while the reliability and robustness are gradually improving as new generations of devices arrive on the market, thanks to the continuous effort of the application designers and engineers who highlight their limits and application opportunities.

## GaN POWER Devices: Long-Term Evolution

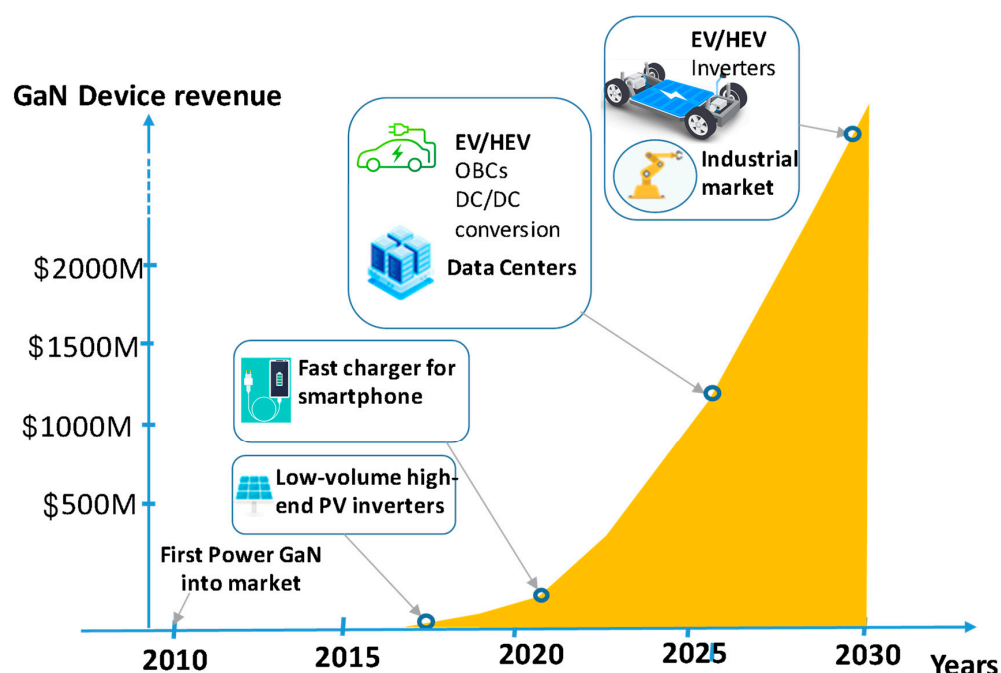

**Figure 1.** GaN power electronic devices in long-term evolution for the Chinese market (Source Power GaN report, Yole intelligence 2023 [7]).

In this article, the impact of the GaN technology in power electronics applications is described and discussed, considering the state of the art and a feasible outlook and perspectives. The article begins with an overview of gallium nitride technology, considering the advantages and drawbacks and examining possible developments. In the next sections, a general survey on the applications of GaN-based devices and their impact in improving the overall performance of the converters compared to competing power devices are described. The promising evolution of the future is also evaluated.

## 2. GaN Technology: Overview and Development

The first gallium nitride devices appeared recently, around 2004, as depletion-mode radio frequency (RF) transistors made in Japan by the Eudyna Corporation. The first semiconductor RF transistor used GaN on silicon carbide (SiC) substrates [8]. After a few years, the GaN-based technology began to be used in power electronics switches in different structural arrangements [9]. In 2009, Efficient Power Conversion (EPC) developed the first enhancement-mode GaN FET. Since this date, the evolution of GaN devices has carried on without stopping for increasingly ambitious targets.

The timeline of the development of GaN-based power devices and the main industrial players involved are depicted in Figure 2.

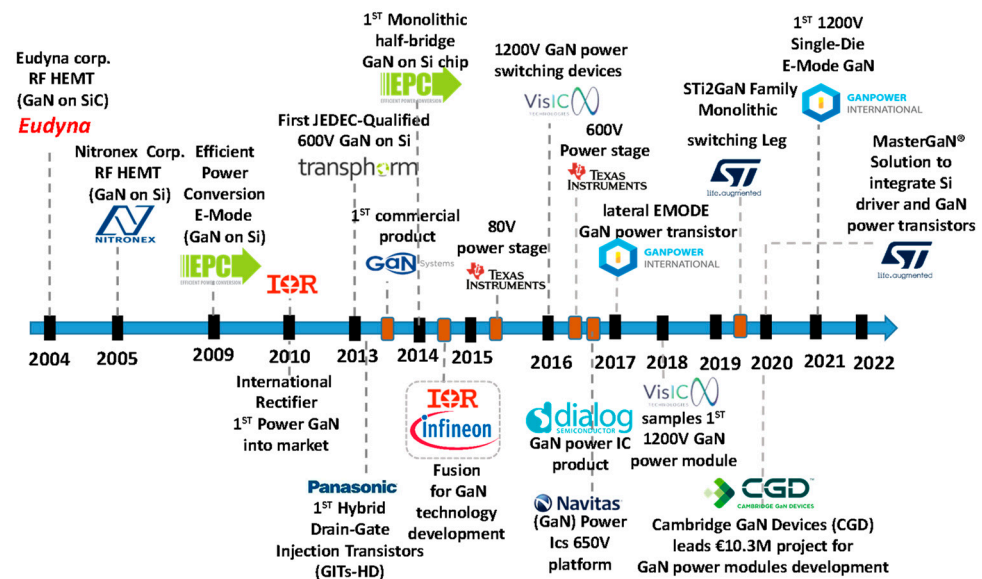

Figure 2. GaN power electronics devices milestones and main industrial players.

GaN power devices are wide-bandgap materials (WBG) belonging to the class of high-electron-mobility transistors (HEMTs). These semiconductor electronic transistors feature a two-dimensional electron gas (2DEG) created by a junction between two crystalline materials featuring diverse atomic spacing and band gaps. The polarization effect induces the 2DEG phenomena in the heterojunction (AlGaIn/GaN), causing the electron's high mobility [1]. Several factors have led power switch designers to put significant effort into making devices with WBG materials. To better recognize the causes behind the advanced performance of WBG power devices, a comparison of the significant material properties of silicon (Si), silicon carbide (SiC), and GaN is graphically depicted in Figure 3a. The SiC devices considered in Figure 3 are 4H-SiC technology. Power electronics device manufacturers use this technology for its isotropic structure [10]. From Figure 3a arises better WBG material properties compared with Si, such as a high thermal conductivity and electron mobility and the breakdown electrical field. GaN and SiC have different behaviors with advantages and drawbacks, making one or the other preferable based on the type of application.

GaN has a lower thermal conductivity than the SiC; indeed, the conductivity of SiC is 2.5 times higher than Si; this increased thermal conductivity feature transfers heat from the semiconductor device junction to the case in an improved way. Better thermal conductivity enables higher current/power densities for SiC devices. Instead, the main GaN peculiarity is the HEMT property, which means that the mobility in the transistor channel is very high. The electron mobility is typically around  $2000 \text{ cm}^2/\text{Vs}$ , almost 100 times higher than SiC MOSFETs. This is a noticeable advantage regarding low ON resistance values. In this way is possible to obtain devices with a much smaller area [11]. Moreover, the switching transients are very short, achieving higher switching frequencies than the SiC devices. After the comparison of the device technologies discussed above, it may be asserted that SiC devices offer a higher power/current density. In contrast, GaN devices provide a lower conduction loss and a higher switching frequency. The device's applications cover different areas of technological development with some overlays, as summarized in Figure 3b. From the point of view of the cost, the SiC material currently has a lower cost than the GaN.

Most manufacturers achieve GaN on Silicon structures on which large-size Si substrates are used for the GaN epitaxial layer growth to exploit the existing facilities and know-how and decrease fabrication costs [12]. The current technological approach led to the development of GaN semiconductor power devices with a lateral structure. In the lateral structure, the electron flow between the source and drain terminals features an inhomogeneous distribution of the electric field in the device, showing a peak in specific

device areas; this phenomenon limits its full voltage-blocking technological potential [13]. Vertical structures for GaN power devices are under development [14]. As in silicon and SiC devices, the vertical design allows for an increase in the breakdown voltage by increasing the thickness of the voltage-blocking layer. The vertical structure is a promising solution for growing penetration in the high-voltage markets dominated by SiC and silicon devices. To develop competitive vertical GaN device structures, some issues must be overcome, such as ion implantation for p-GaN and long-term reliability [15]. Reliability is a crucial constraint for the HEMT devices to be released into extended-power applications for the mass market. The device's reliability is studied by manufacturers in depth to achieve and fulfil standards to keep the GaN structure safe. In particular, the fabrication of the AlGaN crystal can be controlled accurately, and an imperfection or unexpected defects lead to failure in the switching operation [3]. Another aspect to consider related to the ruggedness of GaN devices is the conduction resistance  $R_{DSon}$  during switching events.

GaN power transistors show a dynamic on resistance (Dynamic- $R_{DSon}$ ) increase in switching-mode power converters [16]. In the lateral AlGaN/GaN device structure, the amount of the electric field in the gate edge adjacent to the drain side region strongly influences the Dynamic- $R_{DSon}$  variation. Furthermore, the adjacent semiconductor states and the injection and trapping of electrons affect the regions' degradation, leading to an increase in device loss and temperature (undesired features in the GaN HEMT structure) [17,18].

In recent years, GaN power transistor designers have worked hard on controlling and reducing this phenomenon which leads to serious operating problems during switching in the power converters, degrading its performance with a decrease in the drain current ( $I_D$ ) during switching (called a current collapse) [19].

One example is the advent of the high-voltage, normally off GaN devices of the gate injection transistor (GIT) structure which effectively acts on the degradation of the Dynamic- $R_{DSon}$ . The device injects holes from an additional p-AlGaN layer at the AlGaN/GaN heterojunction to release the trapped electrons and increase the electron density in the channel by drastically reducing the on-state resistance [20].

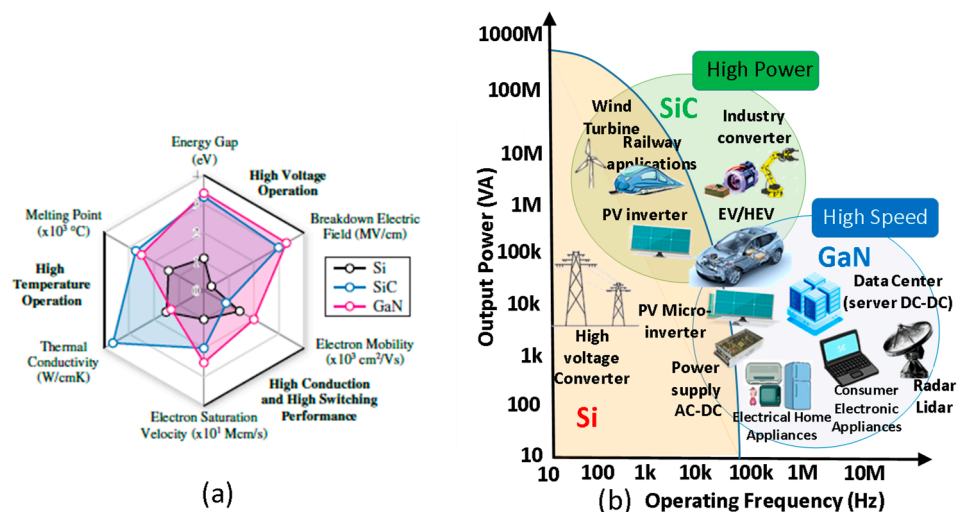
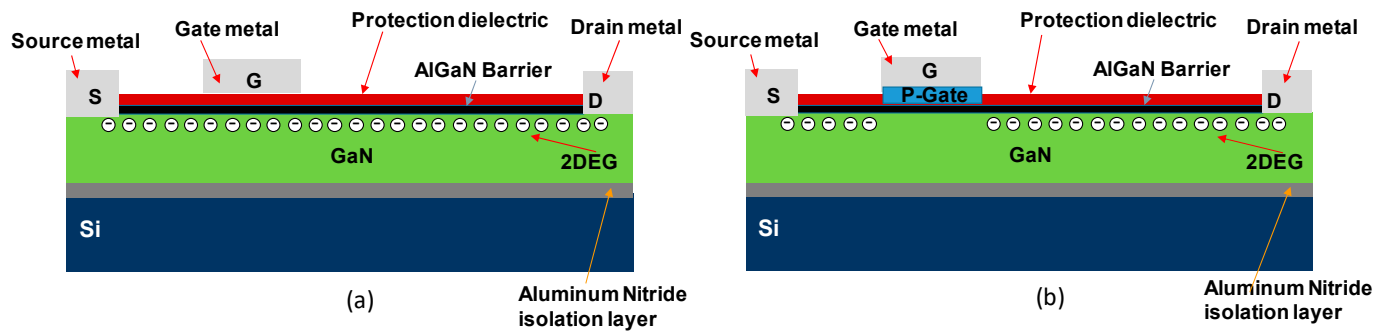

**Figure 3.** (a) Radar chart of the key material properties of Si, 4H-SiC, and GaN devices at ambient temperature (25 °C). Source [21]. (b) Si, SiC, and GaN power electronics switch applications areas.

### 2.1. GaN Power Devices: Classifications and Operation

The transistors based on GaN technology are lateral structure power devices belonging to the field effect transistor (FET) family, with a current conduction channel between the drain and source terminals. A gate voltage modulates the conduction current. The natural operation, similar to FET devices, is in depletion mode, from which the simplest structure of a GaN FET is a normally on switch. A simplified structure of a depletion GaN FET is reported in Figure 4a. Generally, the gate electrode is made via a Schottky contact on

the surface of the layer. The Schottky barrier becomes inversely polarized through the application of a negative voltage to this electrode with respect to the source, bringing the device to the OFF state. Figure 4a highlights the 2DEG created in the heterojunction (AlGaN/GaN). However, the GaN power transistor designer has developed typically off structures to make the HEMT power electronics switch increasingly competitive with SiC- and Si-based GaN FET device structures.

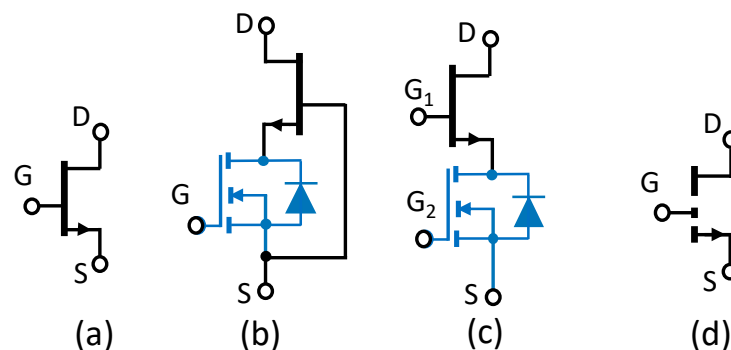

**Figure 4.** (a) Normally on GaN (d-mode): simplified structure. (b) Normally off GaN (e-mode): simplified structure.

The normally off GaN FET is obtained via an enhanced structure (e-mode), as depicted in the simplified structure of Figure 4b (considering the device in its off-state). The positively charged (p-type) GaN gate obtains the e-mode GaN (this is the first commercial device structural arrangement [8]). The layer is grown on top of the AlGaN barrier. The p-type layer effectively depletes the two-dimensional electron gas with  $V_{GS} = 0$ , achieving a normally off device. The 2DEG is fully restored through a suitable positive voltage (greater than the threshold voltage) between the gate and the source.

If the gate voltage is under the device threshold voltage, an equivalent diode behavior appears, and reverse conduction can happen. The virtual equivalent diode in GaN features a voltage drop that is higher than the body diode of a Si MOSFET. It does not show a reverse recovery charge,  $Q_{rr}$  (no minority carriers are involved in the conduction), at the turn-off [21].

Currently, the following GaN power transistor families are available in the HEMT device market (Figure 5).



**Figure 5.** (a) Normally on GaN (d-mode). (b) Normally off Cascode GaN (d-mode). (c) Direct-drive GaN (d-mode). (d) Normally off GaN (e-mode).

The normally on GaN shown in Figure 5a is the basic brick of HEMT GaN devices. The structure is an FET operating in depletion mode (d-mode). It features the lowest  $R_{DSon}$  due to having the simplest structure [21]. The GaN FET is in an on state with a gate voltage ( $V_{GS}$ ) of 0 V, while it is turned off with a  $V_{GS}$  equal to  $-15$  V. Like the FET, the d-mode GaN is naturally bidirectional if the gate voltage polarization enables the conduction channel between the source and drain. Currently, this structure is not on the

market as a single power switch for the normally on state conditions, but it is used to achieve a cascode structure.

The cascode structure reported in Figure 5b attains a switch normally off, adding a low voltage (LV) MOSFET in series with the GaN source. The cascode solution combines the advantaged switching /conduction capability and the structural simplicity of d-mode GaN technology with the friendly gate-driving technique of the Si MOSFET. The GaN FET gate is connected to the MOSFET source to maintain the HEMT device in an on state, while the MOSFET is used for the switching transients. The reverse cascode operation appears when the GaN switch is turned off, the LV Si MOSFET is turned off. In this condition, a reverse voltage is applied to the GaN switch; a current flows through the body diode of the LV Si MOSFET and the channel of the normally on GaN FET with a reduced voltage drop (as it is a naturally bidirectional device). However, an overall lower off state reverse voltage (i.e., <1 V) during dead times is obtained. The cascode configuration may be used in low-voltage applications (<200 V); nevertheless, in high-voltage applications (from 650 V up to 1200), it features a viable usage for higher-current switches [22].

The critical issues of the cascode arrangement are related to the following points:

- The complexity of the package solution;
- The increase in the stray inductances in the power loop;
- The presence of the reverse recovery of the MOSFET body diode;
- The quasi-uncontrolled GaN switching due to a lack of control drive of the HEMT gate.

Figure 5c shows a modified arrangement of the cascode configuration called a direct-drive GaN power transistor. The d-mode GaN gate terminal is not connected to the low-voltage Si MOSFET source in the direct-drive operation. The Si MOSFET is used as a protection device to prevent series shoot through (i.e., requiring an enable gate signal after the converter start-up). The d-mode GaN FET can be directly driven with a negative unipolar voltage (i.e.,  $-15\text{ V}$ ,  $0\text{ V}$ ). The main advantage of this direct-drive arrangement approach is the capability to drive the d-mode GaN FET, exploiting its switching properties and avoiding the uncontrolled commutation of the conventional cascode implementation [21]. Compared to the previous cascode solution, the direct-drive connection increases stray inductances. Furthermore, the two gates available increase the device pin to four.

The enhancement-mode (e-mode) GaN power transistor (Figure 5d) is achieved when the depletion-mode device modifies the gate structure to shift the threshold voltage positively to create a conductive channel [8]. The switching HEMT device is similar to an enhancement-mode MOSFET. The driver circuit must supply a gate voltage from  $0\text{ V}$  to  $+6\text{ V}$ . While the threshold voltage  $V_{GSth}$  is low, in the range of  $1\text{--}2\text{ V}$ , the reverse conduction during the dead time is characterized by an equivalent diode conduction mechanism that causes a higher voltage drop than a MOSFET body diode, increasing the reverse conduction power losses. Currently, the e-mode GaN power transistors are the most widespread family of GaN FET devices and are the group to which the major efforts of academic and industrial designers are directed to optimize performance, as in the case of the high-voltage GIT structure (from Panasonic) already discussed, which was developed to reduce the degradation effect of the dynamic  $R_{DSon}$  [20].

## 2.2. Integration of GaN Structures

The first monolithic half-bridge in a single chip appeared in the GaN market arena in 2014 from EPC [23]. The half-bridge integration reduces the power loop inductances, decreasing the drain voltage peak. Furthermore, the power device's circuit space in the board layout is strongly reduced. In the DC-DC converter for synchronous Buck topology, non-symmetric-area devices are used to optimize the figure of merit (FOM) of the high-side and low-side devices [24]. This monolithic half-bridge solution was the crucial step that led to the integration of driving, control, and sensing with protection functions together in a power stage in the following years. Several GaN power device manufacturers have taken up these technological challenges by providing the market with various integrated solutions with power stages and multiple functions that can be used in typical applications

of both DC-DC and DC-AC converters. Figure 6 depicts some of the most attractive solutions developed in recent years. In Figure 6a, the low-voltage half-bridge monolithic arrangement (EPC 2152 –80 V, 15 A half-bridge as a power stage, from EPC) with two symmetric e-mode GaN transistors integrating all drive circuitry and a level shift with a bootstrap function is depicted [25]. All the power integrated circuits (ICs), power stages, and signal circuits are developed in GaN technology. The GaN FET symbol for EPC maintains the MOSFET drawing arrangement. This integrated half-bridge can be used in DC-DC converters as single switching legs and in inter-leaving arrangements and inverters for low-power brushless DC (BLDC) motors, such as in e-bike applications [26].

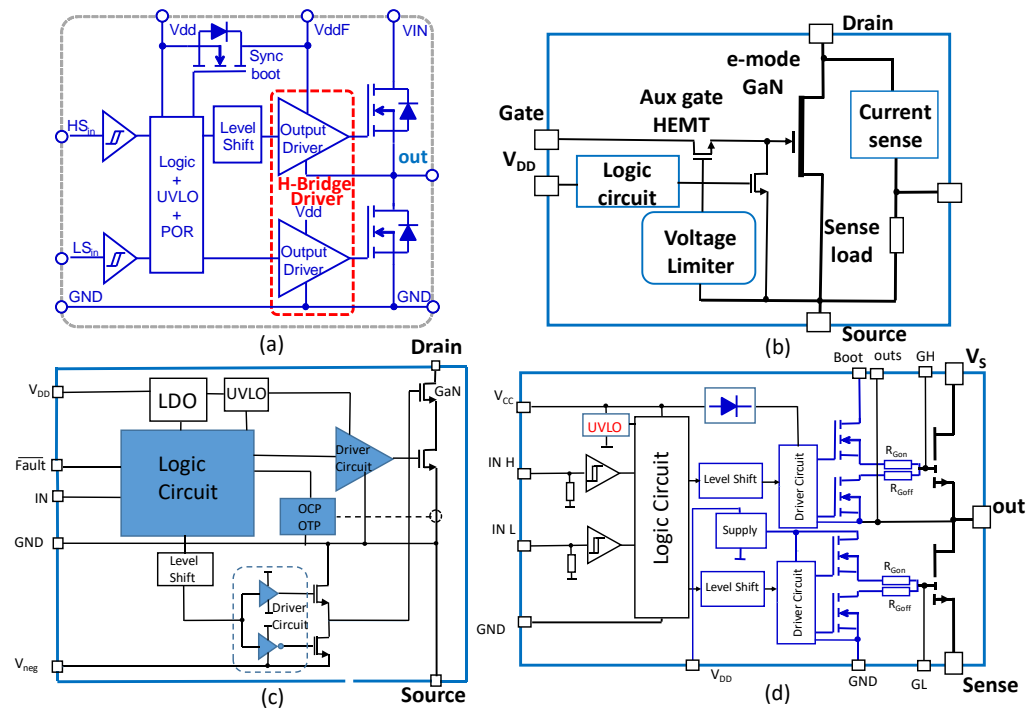

**Figure 6.** (a) Low-voltage switching leg power stage integrated with driver and protection circuit, source [25]. (b) High-voltage normally-off e-mode GaN FET integrated with driver and protection circuit from CGD, source [27]. (c) High-voltage direct-drive GaN FET (d-mode). From Texas Instruments, source [28]. (d) High-voltage normally-off (e-mode) GaN FET half bridge in SiP arrangement from STMicroelectronics [29].

Cambridge GaN Devices (CGD) offers several integrated circuit solutions (at 650 V). In Figure 6b, the single e-mode high-voltage monolithic GaN power stage, IceGaN™, with smart sensing and protection and controller and driver function is reported. The integrated solution is to drive it the same as a Si MOSFET. IceGaN™ accepts an input voltage  $V_{in}$  from 0 to 20 V, and the threshold voltage is augmented to 3 V for better driving control [27]. The application is oriented to a DC-DC single-switch converter, such as a quasi-resonant Flyback converter, for consumer power supply. The Texas instrument provides the LMG341x family’s integrated cascode solution (power stage: 600 V; 40 A at 25 °C) with a direct-drive implementation and driver and protection circuits [28]. The schematic of the power integrated circuit (IC) is shown in Figure 6c. A key feature of the gate driver is the control of the slew rate during hard-switching transients. The protection circuits associated with the function direct-drive solution allow for an increase in the reliability of the integrated GaN-based cascode device.

STMicroelectronics has developed “MasterGaN” devices, an integrated platform (system-in-package, SiP) embedding a silicon technology half-bridge driver with two e-mode GaN transistors in a switching-leg configuration (Figure 6d). Currently, the integrated switching-leg MasterGan1 features 600 V with 10 A at 25 °C of drain current [29]. As shown

in Figure 6, the GaN devices' circuit symbol is still non-uniform; every manufacturer draws the GaN power transistor in a different mode. It is necessary to define a standard symbol in the future.

In this field of power, GaN transistor integration highlights the monolithic solution for two GIT GaN devices arranged in a single chip to obtain a bidirectional switch, which has been realized in recent years for applications in protection power switches for voltages up to 400 V and hybrid relays [30].

A system-on-chip (SoC) circuit is much more attractive for the reduced number of components and space occupied by the power converter achieved. The target of future integrated structures based on HEMT GaN technology is to achieve a single-power IC that is driven by a microcontroller with a simple digital signal, high switching performances, and adequate current density [31].

The power modules are another crucial target for obtaining high-current power switches to compete with SiC MOSFET devices in high-power applications. In [32], a prototype of a 650 V/60 A GaN power module in an SP1 package is described. The basic power stage is a cascode configuration (as reported in Figure 5b). In the power module, a switching leg with two cascode devices in parallel connection in the high-side and low-side positions, respectively, is implemented. Furthermore, an RC snubber is integrated to control the drain voltage slope. The power module production for high-current devices in e-mode GaN power transistors is related to the development of the vertical HEMT structure. It is a perspective to consider in the coming years.

### 2.3. Package Solutions

The package solution plays a crucial role in reducing parasitic inductances to allow for an increase in switching frequencies without high ringing in the converter circuit waveforms and while avoiding drain voltage overshoot. A low-inductance package design is crucial. A suitable package material and layout decrease heat dissipation and limit electromagnetic interference (EMI). A GaN FET features a die size smaller than a MOSFET of an equivalent current density and breakdown voltage characteristics, allowing for a noticeable decrease in the package volume. Furthermore, the GaN FET case must achieve efficient cooling paths on the top and bottom sides.

Furthermore, electrical insulation is requested for a ground-referenced heat sink for a half-bridge topology [33]. An illustrative example regarding low-voltage e-mode GaN devices relating to EPC manufacture is the chip-scale package (CSP) arrangement. This package layout has "solderable bars" on the device surface. The developed solution allows a direct solder onto a printed circuit board (PCB). The CSP achieves a noticeable decrease in stray inductance.

Furthermore, efficient cooling can be obtained. The CSP solution is illustrated in Figure 7. The solderable bars are depicted in Figure 7a with the pin connections. In Figure 7b, the package assembly on the PCB is described. Finally, a photo of a half-bridge circuit in a CSP arrangement on the PCB top layer is shown in Figure 7c.

For high-voltage, the Discretes Flat No-leads (DFN) package is used by several manufacturers for an achievable high-voltage (up to 1200 V) that exhibits few stray inductances. For integrated GaN technology, the Quad Flat No-Lead (QFN) package is preferred, with some improvement as described in [34]. The growth of GaN devices in the semiconductor market goes hand in hand with the development of packages that can exploit the advantage of the switching characteristics of HEMT transistors, featuring a compact size to reduce parasitic inductance and the isolation strength capability to achieve the high-voltage switches that are increasingly demanded. Furthermore, the package solutions must exhibit a relevant heat dissipation capacity on both the bottom and high sides of the case.

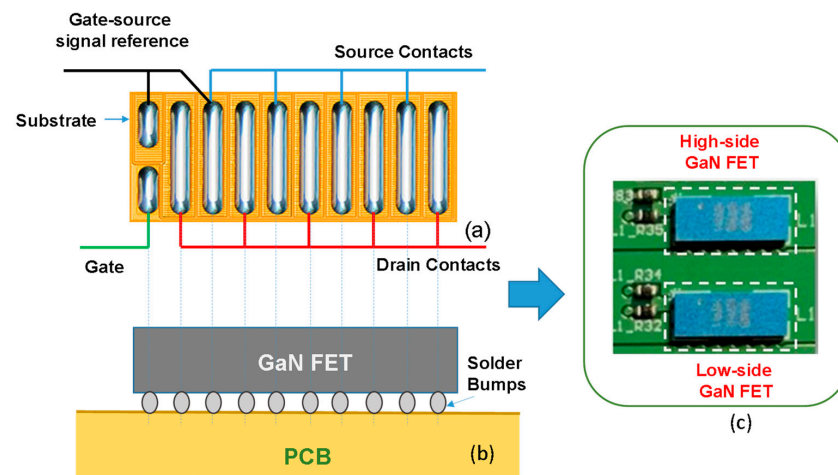

**Figure 7.** (a). Package description of solderable bars with source, drain, gate, and substrate contacts. (b) Package on the PCB arrangement. (c) Picture of a top layer of a half-bridge PCB with two devices in the CSP package.

### 3. GaN in Power Electronics Applications

E-mode GaN FETs are already used in several power electronics application areas. At a low voltage, the superior characteristics of HEMT devices allow for the increasing use of GaN FETs over silicon MOSFETs. There are electrical benefits and a reduction in the space occupied, making HEMT components very attractive for producing compact and efficient electronic equipment. As mentioned above, the currently higher cost than the MOSFETs is the principal limit for the even more widespread use of GaN FETs. In high-voltage power electronics systems, other established devices in these fields include WBG SiC MOSFETs and the more technologically mature silicon super-junction (SJ) MOSFETs and IGBT devices. This condition causes GaN power transistors to be used for a restricted but crucial area of application with a need for higher switching frequencies. In [35], a comparison of power losses among several SiC MOSFETs, SJ silicon MOSFETs, and GaN FETs (in d-mode cascode switching devices) at 400 V of DC bus and a different load current amplitude performed on inductive switching (Figure 8a) versus the switching frequency, show clearly the area of the best application of the tested silicon and WBG devices, as reported in Figure 8b. However, the GaN power transistors in high-voltage applications are increasingly experimented with in various fields of power converter applications, such as battery chargers in the automotive area or photovoltaic inverters [36,37], to recognize the advantages and disadvantages of the GaN FETs applications (in d-mode cascode and e-mode configurations) in these critical areas of the sustainable development in energy conversion. Several power electronics applications are discussed in the following to overview of the GaN FETs' impact.

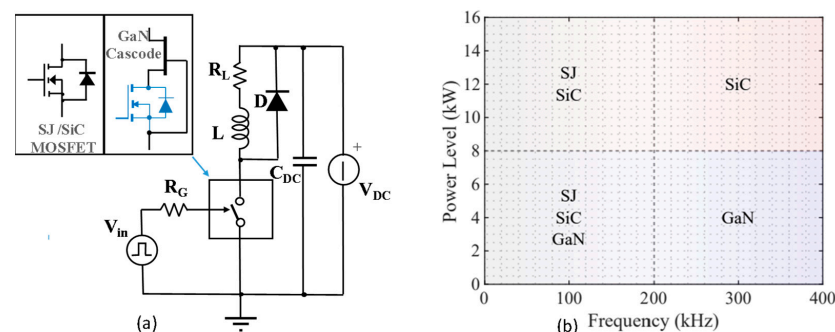

**Figure 8.** (a) Inductive-load-switching test circuit schematic. (b) Application areas trend for SiC, SJ, and GaN technologies. Drain-source voltage equal to 400 V, power levels in the range of 1 kW to 16 kW (current amplitude: 1 A–40 A), and switching frequencies from 1 kHz to 500 kHz [35].

### 3.1. GaN for DC-DC Power Converters

The power brick DC-DC converter is strongly diffused in power supply arrangements for industrial and domestic electronic equipment such as game consoles, laptops, computers, servers, communication networking, and storage systems. The power brick that complies with the standard sizes and footprints settled by the Distributed-power Open Systems Alliance (DOSA) is the solution for a flexible modular power supply. The advantage of using the power brick is that the equipment design engineers do not need to be experts in power supply design [38]. The power brick comprises the switching topology (a synchronous buck or boost topology) and a controller. For example, a typical 1/16th brick has a 48 V input, an output voltage of 12 V, and 25 A of output current (300 W). The power density per unit area is a crucial challenge for the brick arrangement. HEMT devices are excellent candidates for compact and high-efficiency modular power supply systems. The low-voltage GaN FETs feature a compact footprint with an outstanding FOM. The size and shape of the magnetic components can be improved via the increasing switching frequency achievable by GaN FETs. Furthermore, using high-switching HEMT devices reduces dead time in the implementation of a synchronous buck converter [39]. Choosing a GaN-compatible controller is a challenge for obtaining a high-performance power brick.

The advantages in terms of the main electrical parameters of a low-voltage e-mode GaN FET (GS61004B from GaN System in GaNPX<sup>®</sup> packaging) for a power brick application compared with an equivalent application trench-gate MOSFET (ISZ230N10NM6 from Infineon in a PG-TSDSON-8FL package) are reported in Table 1. The trench-gate-technology MOSFET device used has a very advantageous FOM (achieved by the product of  $R_{DSon}$  and  $Q_G$ ) when compared to MOSFET devices with an equivalent  $R_{DSon}$  resistance. It features a very low gate charge  $Q_G$  with respect to most MOSFETs available on the market. Despite the small  $Q_G$  of the chosen MOSFET, the FOM is very favorable to the GaN FET device, as shown in the graph of Figure 9a, related to the results in Table 1. The output capacitor  $C_{oss}$  is a parameter related to the switching losses [21,40]. The MOSFET shows a higher  $C_{oss}$  than the GaN FET. In reverse conduction, the e-mode GaN power transistor shows an equivalent diode behavior with  $Q_{rr} = 0$  but with a higher voltage drop. Generally, the dead-time reverse-conduction losses are lower for the MOSFETs, but the dead-time duration is strongly reduced for GaN FET devices [41]. The switching characteristics are strongly advantageous for GaN FETs, as demonstrated by the FOM features. However, the high frequency that can be reached brings a crucial cure in the layout arrangement to reduce the stray inductances in the power loop and gate circuit. Furthermore, the GaN FET cost currently is higher than the cost of a Si MOSFET.

**Table 1.** Comparison of low-voltage (100 V) main electrical parameters between a commercial e-GaN and an equivalent application trench-gate MOSFET device. The reference temperature is 25 °C.

LV Device	$I_D$ (A)	$V_{DS}$ (V)	$V_{GS}$ (V)	$R_{DSon}$ (m $\Omega$ )	$C_{oss}$ (pF)	$Q_G$ (nC)	$Q_{rr}$ (nC)	$V_F$ (V)
e-mode GaN	38	100	−10 to +7	16	110	3.3	0	2.3
MOSFET	31	100	±20	23	150	9.3	23	1

**Table 2.** Comparison of high-voltage (650 V) main electrical parameters comparison among a commercial e-GaN and equivalent application SiC MOSFET and SJ MOSFET devices. The reference temperature is 25 °C.

HV Device	$I_D$ (A)	$V_{DS}$ (V)	$V_{GS}$ (V)	$R_{DSon}$ (m $\Omega$ )	$C_{oss}$ (pF)	$Q_G$ (nC)	$Q_{rr}$ (nC)	$V_F$ (V)
e-mode GaN	30	650	−10 to +7	50	65	6.1	0	3.3
SiC MOSFET	35	650	−5 to 18	58	73	29	30	3
SJ MOSFET	30	650	±20	86	84	33	5100	1.2

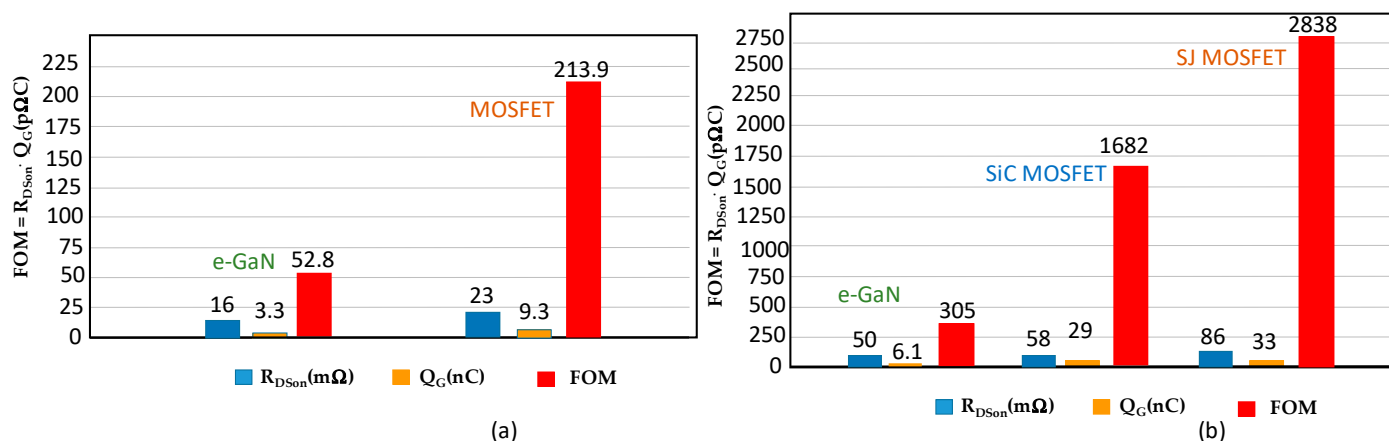

**Figure 9.** (a)  $R_{DS(on)}$ ,  $Q_G$ , and FOM comparison between a low-voltage (100 V) e-mode GaN FET and Si MOSFET related to Table 1. (b)  $R_{DS(on)}$ ,  $Q_G$ , and FOM comparison among a high-voltage e-mode GaN FET with a SiC and Si MOSFETs related to Table 2.

The LLC resonant converter is one of the topologies in which the use of e-mode GaN FETs allows for the achievement of the best power density [42]. The zero voltage switching achieved in an LLC converter permits an increase in efficiency, and the high switching frequency reachable (from 1 to tens of MHz) dramatically reduces the resonant tank's size. The LLC converter is one of the much-used converter topologies for inductive wireless power transfer (WPT) systems [43]. Compared with traditional Si-based MOSFETs, the compact size obtained with HEMT devices is a crucial factor for wireless charging applications, especially in drone applications [44] where the available space for the charger is limited. Another relevant field of application is the lighting of LEDs for driving. GaN devices, with their high switching frequency and high-power density characteristics, enable compact and efficient driving systems that can be inserted into the lamp, reducing the overall size [45].

In high-current applications such as in the battery interface (for example, in a 48 V mild-hybrid system), the DC-DC converter is arranged with bidirectional switching legs in an interleaved solution [46]. The GaN FET used must be automotive-qualified. The interleaved solution is associated with a high switching frequency, allowing for a substantial reduction in the current ripple and a reduction in the size of the inductor. Furthermore, the monolithic solution described above (Section 2.2) permits a compact size layout that is crucial for automotive applications.

In high-voltage e-mode GaN FET applications, the battery charger is one of the most diffused power electronic systems. The HEMT device may make a solid effort to increase the switching performance and reduce the occupied converter volume. Considering a typical voltage of 400 V for the DC bus, the maximum rated voltage for the switching device in a common half-bridge topology used for these kinds of applications  $V_{DSmax}$  is 650 V. Using this design constraint, three different technology-based devices are compared. In Table 2, the main electrical parameters for a high-voltage e-mode GaN FET (GS66508B from GaN System in e GaNPX<sup>®</sup> package) are compared with an equivalent application SiC MOSFET (SCT055HU65G3AG from STM, in U3PAK package) and a silicon super junction (SJ) MOSFET (SiHB100N60E from Vishay in D2PAK—TO-263). From Table 2, the better switching characteristics of the e-mode GaN FET arise.

Figure 9b depicts the graphics of the FOM comparison in relation to the Table 2 results. In this range of voltage, the e-mode GaN FET can be an effective alternative to SiC and Si MOSFETs. Over the cost, the maximum voltage currently available due to the lateral physical structure is the main drawback limiting market penetration. One of the critical disadvantages of GaN-HEMTs in DC-DC converter applications is their reduced capability to withstand unclamped inductive switching (UIS) [47], which is caused

by the non-removable structure of holes generated by the avalanche breakdown. The UIS ruggedness and capability of GaN FET HEMTs can be improved via a technological design approach that implements a hole removal structure and optimized package thermal resistance [48].

Furthermore, short-circuit robustness (SC) has been studied recently. The experimental investigations in [49,50] show that high voltage (until 650 V) GaN FET e-mode devices can sustain the SC for the standard 10  $\mu$ s with a drain–source voltage  $V_{DS}$  lower than about half the maximum expected voltage. This crucial fault condition must be further investigated to furnish detailed information to the GaN FET designers to improve the switch SC ruggedness.

Recently, developers of HEMT devices have also been experimenting with multilevel converters, such as flying capacitor inverter topology, to exploit the compactness of GaN transistors and the high switching frequencies in these power circuits [51]. The investigation into the application of the DC-DC modular multilevel converter (MMC) for solar electric propulsion in spacecraft power systems is described in [52]. For high voltages, d-mode GaN Power transistors in cascode configuration are currently used.

### 3.2. GaN in Motor Drive Applications

In recent years, the use of GaN FETs for low voltages has experienced remarkable development in applications for inverter drives for brushless direct current (BLDC) and AC motors (mostly for voltages < 200 V) due to the possibility of reaching high switching frequencies ( $\geq 100$  kHz), reducing the overall dimensions of the inverter, and therefore allowing for the integration of the motor, inverter, and control in a single compact system obtaining an efficient and integrated modular motor drive [53]. Light e-mobility devices, such as E-kick scooters, e-Bikes, skateboards, hoverboards, low-speed EVs, segways, mopeds, and e-scooters, benefit from the advantages of the HEMT GaN technology [54]. In low-voltage motor drives, the DC bus voltage  $V_{DC}$  is in the range of 24–96 V. The switching frequency for a MOSFET-based inverter is equal to or below 40 kHz. The dead time with MOSFET switching legs is maintained from 200 ns to 500 ns. The dead-time length impacts the generation of a sixth harmonic on the electrical frequency of the generated torque. This harmonic amplitude influences the motor efficiency performance, increasing the mechanical vibration and the winding temperature [55]. Dead time in e-mode GaN FETs can be reduced to tens of ns, improving the quality of the waveform and drastically decreasing the sixth harmonic effect [56]. From the point of view of power losses, the reverse conduction in GaN FETs must be maintained as low as possible to avoid cross-conduction in the inverter legs as well as to reduce the power losses caused by the higher voltage drop of the equivalent diode conduction [57].

An e-mode GaN FET inverter easily reaches 100 kHz of switching frequency. By increasing the PWM frequency, a double-positive effect can be achieved. The first advantage is the current ripple reduction. The second advantage is the input voltage ripple decrease that consequently permits a DC link capacitor reduction. Furthermore, at a conventional motor drive switching frequency (maximum 40 kHz with Si MOSFET in low voltage applications), the DC link capacitor is generally arranged with the electrolytic capacitor. When increasing the switching frequency, the capacitance values decrease, allowing for the use of ceramic capacitors. The non-polarized capacitors feature a lower series resistance (ESR) with a minimum in the range of 100–200 kHz, showing good temperature stability and reliability. The substantial reduction in the inverter input filter also influences the inverter's efficiency and compactness [26]. From the above consideration, the low-voltage DC battery-powered motor is moving from a Si-MOSFET-based inverter to HEMT e-mode GaN technology in the coming years. In high-voltage inverter applications, there are several experimental prototypes and investigations from academic and industrial researchers. In [53], a three-phase inverter based on the e-mode GaN transistor GS66516T produced by GaN Systems is experimentally evaluated ( $V_{DC} = 350$  V, an output rated current of 90 A for phase, at 20 kHz of switching frequency). Furthermore, an IMMD design approach

using GaN power transistors for inverter-driving permanent magnet synchronous motors (PMSMs) is presented in [58]. The application of high-voltage GaN power transistors in two-level and especially in multi-level inverters are in development, and exciting results are expected in the following years.

### 3.3. GaN for LIDAR Application

Light detection and ranging (LIDAR) identifies the technology that measures the distance to an object by illuminating it with laser light. Lidar is currently used as a remote recognition device for developing self-driving vehicles and for ADASs (advanced driver assistance systems).

Two modes of operation are prevalent in LIDAR applications: direct time of flight (DToF) and indirect time of flight [23]. The first LIDAR form sends individual pulses and measures the time of reflection to calculate the distances. The IToF method compares the phase of the transmitted and reflected signal pulse to calculate the distance of the target. In recent years, the IToF solution has grown for its versatility, simple design, and low cost. IToF is applied mainly in the medium range of distances (from 1 m to 10 m). It is primarily used in robots, unmanned aerial vehicles (UAV), and autonomous drive vehicles. The principle of operation of the IToF is shown in Figure 10a.

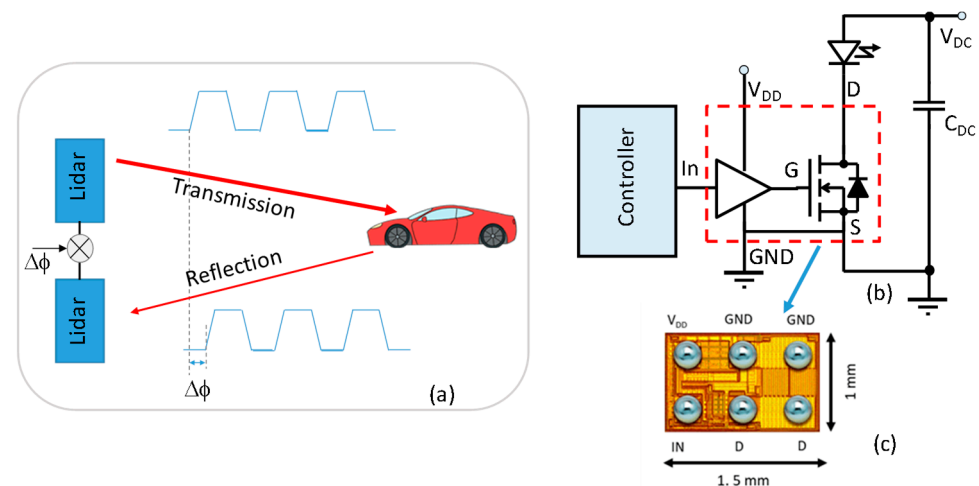

**Figure 10.** (a) Indirect time of flight system principle. (b) Simplified power circuit for the laser-pulse current generation with an e-mode GaN FET power stage and integrated driver circuit (EPC21601). (c) Picture of the die where the GaN FET power stage and driver circuit are integrated.

The LIDAR laser requires a specific pulse current for operation in the ToF system. The current pulse must be obtained through a low-voltage circuit based on a switch capable of quickly managing high currents. The e-mode GaN FET is an excellent candidate for this kind of application. In this direction, the EPC has developed an integrated power stage and driver circuit with a voltage switching time of 750 ps at a typical voltage supply of 30 V with 15 A of the peak current that is suitable for LIDAR operation and an operative frequency up to 200 MHz [59]. One of the most-used circuit topologies for implementing such a pulse laser current is shown in Figure 10b, and the layout of the IC, with the power stage and control circuit, is depicted in Figure 10c. The benefit of HEMT GaN technology is the compactness of the integration solution, which reduces the circuit part count associated with the reachable high-switching transients.

## 4. Discussion

The advent of GaN HEMT technology for power electronics has brought a novel breath of fresh air to the semiconductor power device arena. Gallium nitride, which is grown as a thin film on top of a standard silicon substrate, creates new horizons for developing fast and compact devices for increasing efficiency and performing applications. The integration

capability in the lateral GaN devices developed by several manufacturers allows for a reduction in the count-part of components for developing effective and innovative high-frequency power circuits. HEMT characteristics lead to a revolutionary layout arrangement to avoid ringing voltage due to stray inductances on the power loop. The power stage and driver circuit integration (SoC) are moving toward this target. A crucial point in the challenge of the massive application of HEMT GaN power transistors is the development of packages able to reduce the parasitic inductances and optimize the thermal management in the bottom and upper sides of the case. The GaN FET in modules arrangement is a further challenge. The e-mode GaN FET in a vertical structure is a future target for increasing the modular arrangement capability and maximum voltage available. Currently, the maximum high-current and high-voltage technologies are obtained in the cascode configuration of d-mode GaN devices. To increase the voltage managed, a multilevel converter will be investigated extensively in terms of advanced topology, innovative layout, and thermal management. Moreover, the technology development for high-voltage devices is moving on an innovative concept, the multi-channel monolithic-cascode high-electron-mobility transistor (MC<sup>2</sup>-HEMT), in which the low-voltage device is an e-mode GaN FET. Instead, the high-voltage device is a d-mode HEMT GaN FET. In [60], the voltage of the first devices developed was 3 kV, and the maximum voltage forecast for this new concept of GaN-based devices may go up to 10 kV.

In low-voltage applications, the e-mode GaN FETs feature broad application fields for superior performance compared to the equivalent pure silicon MOSFET devices. Si MOSFETs are still widely used due to the high knowledge of their static and dynamic characteristics in the various fields of power electronics and the maturity of the vertical structure technology. Meanwhile, the applications of lateral e-mode GaN FET devices are still under study, and the development of specific power converters is required. For example, Si MOSFETs have been investigated extensively in a parallel connection to obtain a fast and high current switch, while the behavior of GaN FETs is under study to optimize the parallel assembly [61,62]. Furthermore, another important limit for market penetration in consumer power electronics is the high cost. Cost reduction is a crucial future target for the extensive use of GaN FETs. GaN technology-manufacturing devices are working hard to obtain increasingly competitive construction processes. However, there are application fields, such as the case of LIDAR, where GaN FETs have become significantly necessary despite the high cost due to their high switching speed characteristics.

## 5. Conclusions

In this paper, an overview of HEMT GaN FET devices for low-voltage and high-voltage applications in the power electronics area are discussed, considering the state of the art and perspective. A GaN technology overview is presented, and the electrical characteristics are compared with pure Silicon and SiC MOSFETs. The high switching speed of the GaN power transistors allows for a compact design and more efficient power converters than Si and SiC MOSFETs. In the paper, the low-voltage and high-voltage device features and applications are evaluated to highlight their benefits and limits. From the outcome reported, the capability arises to use much more extensive e-mode GaN FETs in low-voltage power converters. The trend of growth of the e-mode GaN FETs shows that HEMT devices are moving on to substitute Si MOSFETs in several applications in the near future. In the high-voltage field, the use of GaN FETs in e-mode and d-mode in cascode configurations suffers from several competitors, such as Si IGBTs and SJ MOSFETs or WBG SiC MOSFETs. The lateral GaN FETs structure still does not reach the high current delivered by Si IGBT or WBG SiC modules. Still, for a lower current, the power converter compactness achievable with the GaN FETs is an enabling factor for its use in different types of applications, from lower power to medium power applications that require high frequencies of operation. The vertical structure of the GaN FETs would allow for the achievement of higher maximum voltages and modules that may be implemented more easily. Currently, vertical structure arrangement is under investigation, and significant results are expected in the next few

years. Finally, GaN FETs are promising devices for improving the efficiency, compactness, and high-frequency operation of battery-powered equipment, e-mobility devices, wireless power transfer chargers, etc. The benefits of the advantages of HEMT technology and its further improvements are foreseen for the near future.

Shortly, the main advantages and drawbacks of GaN FET power transistors applied in the power electronics converters investigated are summarized in Table 3.

**Table 3.** Main advantages and drawbacks of GaN FET in the investigated power electronics applications.

Application	Advantages	Drawbacks
DC-DC power converters for power supply or battery charger applications	<ul style="list-style-type: none"> <li>Higher power density per unit area;</li> <li>High switching frequency achievable (tens of MHz);</li> <li>Size of magnetic components reduction;</li> <li>Dead time reduction.</li> </ul>	<ul style="list-style-type: none"> <li>Higher cost than SiC MOSFET and Si MOSFET;</li> <li>Special cure in the PCB layout arrangement;</li> <li>Limits in maximum voltage reachable for the current physical lateral structure adopted;</li> <li>Critical UIS and short circuit management.</li> </ul>
DC-AC Power converters for motor drive applications	<ul style="list-style-type: none"> <li>Decreasing the motor's sixth harmonic torque by reducing dead time;</li> <li>Output current ripple reduction thanks to a higher switching frequency;</li> <li>Input voltage ripple decrease and DC link capacitor reduction.</li> </ul>	<ul style="list-style-type: none"> <li>Device cost;</li> <li>Special cure in the PCB layout arrangement;</li> <li>Both high <math>dv/dt</math> and voltage-ringing control to avoid motor insulation damage;</li> <li>Critical short-circuit fault condition management.</li> </ul>
LIDAR	<ul style="list-style-type: none"> <li>Lower <math>R_{Dson}</math>, which achieves lower conduction losses;</li> <li>Lower parasitic capacitances, decreasing in power losses during charging/discharging with the higher switching frequency;</li> <li>Smaller devices with less overheating, lower board-space requirements, and higher reliability.</li> </ul>	<ul style="list-style-type: none"> <li>Higher cost than Si MOSFET;</li> <li>Special cure in the management of stray inductances with a design approach typical of RF circuits.</li> </ul>

To continue this overview work, the next evolution of the investigation into the e-mode GaN FET as a switch in power converter applications will regard two key points. The analysis of the monolithic structures' impact on the ruggedness and compactness of the power converter system and the realization of a high-current switch through an optimized parallel connection.

**Author Contributions:** Conceptualization, S.M. and V.B.; methodology, S.M.; software, V.B.; validation, S.M. and V.B.; formal analysis, S.M.; investigation, S.M. and V.B.; resources, V.B.; data curation, S.M. and V.B.; writing—original draft preparation, S.M.; writing—review and editing, S.M.; and V.B.; visualization, V.B.; supervision, S.M.; project administration, S.M.; funding acquisition, S.M. All authors have read and agreed to the published version of the manuscript.

**Funding:** This research was funded by Ministero (MIUR) PRIN, Innovative Solutions for Renewables in Energy Communities (ISoREC): 202054TZLF.

**Conflicts of Interest:** The authors declare no conflict of interest.

## References

- Meneghini, M.; De Santi, C.; Abid, I.; Buffolo, M.; Cioni, M.; Khadar, R.A.; Nela, L.; Zagni, N.; Chini, A.; Medjdoub, F.; et al. GaN-based power devices: Physics, reliability, and perspectives. *J. Appl. Phys.* **2021**, *130*, 181101. [\[CrossRef\]](#)
- Sun, B.; Jorgensen, K.L.; Zhang, Z.; Andersen, M.A. Research of Power Loop Layout and Parasitic Inductance in GaN Transistor Implementation. *IEEE Trans. Ind. Appl.* **2020**, *57*, 1677–1687. [\[CrossRef\]](#)
- Zhong, Y.; Zhang, J.; Wu, S.; Jia, L.; Yang, X.; Liu, Y.; Zhang, Y.; Sun, Q. A review on the GaN-on-Si power electronic devices. *Fundam. Res.* **2022**, *2*, 462–475. [\[CrossRef\]](#)
- Wang, J.; Li, Y.; Han, Y. Integrated Modular Motor Drive Design with GaN Power FETs. *IEEE Trans. Ind. Appl.* **2015**, *51*, 3198–3207. [\[CrossRef\]](#)
- Lipu, M.S.H.; Miah, S.; Ansari, S.; Meraj, S.T.; Hasan, K.; Elavarasan, R.M.; Al Mamun, A.; Zainuri, M.A.A.M.; Hussain, A. Power Electronics Converter Technology Integrated Energy Storage Management in Electric Vehicles: Emerging Trends, Analytical Assessment and Future Research Opportunities. *Electronics* **2022**, *11*, 562. [\[CrossRef\]](#)
- Kumar, A.; Moradpour, M.; Losito, M.; Franke, W.-T.; Ramasamy, S.; Baccoli, R.; Gatto, G. Wide Band Gap Devices and Their Application in Power Electronics. *Energies* **2022**, *15*, 9172. [\[CrossRef\]](#)

7. China's Lead in Power GaN Consumer Devices Drives the Future Use in Telecom/Datacom and Automotive. Yole Group. 2 March 2023. Available online: <https://www.yolegroup.com/strategy-insights/chinas-lead-in-power-gan-consumer-devices-drives-the-future-use-in-telecom-datacom-and-automotive/> (accessed on 5 April 2023).
8. Lidow, A.; De Rooij, M.; Strydom, J.; Reusch, D.; Glaser, J. *GaN Transistors for Efficient Power Conversion*, 3rd ed.; John Wiley & Sons: Hoboken, NJ, USA, 2019.
9. Liu, A.-C.; Tu, P.-T.; Langpoklakpam, C.; Huang, Y.-W.; Chang, Y.-T.; Tzou, A.-J.; Hsu, L.-H.; Lin, C.-H.; Kuo, H.-C.; Chang, E.Y. The Evolution of Manufacturing Technology for GaN Electronic Devices. *Micromachines* **2021**, *12*, 737. [[CrossRef](#)]
10. Liu, Y.; Lin, Z.; Cui, P.; Fu, C.; Lv, Y.; Cheng, Z. Influence of polarization Coulomb field scattering on high-temperature electron mobility in AlGaIn/AlN/GaN heterostructure field-effect transistors. *Superlattices Microstruct.* **2018**, *120*, 389–394. [[CrossRef](#)]
11. Dimitrijević, S.; Han, J.; Haasmann, D.; Moghadam, H.A.; Aminbeidokhti, A. Power-switching applications beyond silicon: The status and future prospects of SiC and GaN devices. In Proceedings of the 2014 29th International Conference on Microelectronics Proceedings—MIEL 2014, Belgrade, Serbia, 12–14 May 2014; pp. 43–46. [[CrossRef](#)]
12. Chen, K.J.; Häberlen, O.; Lidow, A.; Iin Tsai, C.; Ueda, T.; Uemoto, Y.; Wu, Y. GaN-on-Si Power Technology: Devices and Applications. *IEEE Trans. Electron Devices* **2017**, *64*, 779–795. [[CrossRef](#)]
13. De Santi, C.; Buffolo, M.; Rossetto, I.; Bordignon, T.; Brusaterra, E.; Caria, A.; Meneghesso, G. Review on the degradation of GaN-based lateral power transistors. *E-Prime—Adv. Electr. Electron. Energy* **2021**, *1*, 100018. [[CrossRef](#)]
14. Meneghesso, G.; Meneghini, M.; De Santi, C.; Zanoni, E. GaN-based lateral and vertical devices: Physical mechanisms limiting stability and reliability. In Proceedings of the 2019 Electron Devices Technology and Manufacturing Conference (EDTM), Singapore, 12–15 March 2019; pp. 68–70. [[CrossRef](#)]
15. Oka, T. Recent development of vertical GaN power devices. *Jpn. J. Appl. Phys.* **2019**, *58*, SB0805. [[CrossRef](#)]
16. Kuring, C.; Tannhaeuser, M.; Dieckerhoff, S. Improvements on Dynamic On-State Resistance in Normally-off GaN HEMTs. In Proceedings of the PCIM Europe 2019, International Exhibition and Conference for Power Electronics, Intelligent Motion, Renewable Energy and Energy Management, Nuremberg, Germany, 7–9 May 2019; pp. 1–8.
17. Yang, S.; Han, S.; Sheng, K.; Chen, K.J. Dynamic On-Resistance in GaN Power Devices: Mechanisms, Characterizations, and Modeling. *IEEE J. Emerg. Sel. Top. Power Electron.* **2019**, *7*, 1425–1439. [[CrossRef](#)]
18. Wang, W.; Liang, Y.; Zhang, M.; Lin, F.; Wen, F.; Wang, H. Mechanism Analysis of Dynamic On-State Resistance Degradation for a Commercial GaN HEMT Using Double Pulse Test. *Electronics* **2021**, *10*, 1202. [[CrossRef](#)]
19. Ho, S.-Y.; Lee, C.-H.; Tzou, A.-J.; Kuo, H.-C.; Wu, Y.-R.; Huang, J. Suppression of Current Collapse in Enhancement Mode GaN-Based HEMTs Using an AlGaIn/GaN/AlGaIn Double Heterostructure. *IEEE Trans. Electron Devices* **2017**, *64*, 1505–1510. [[CrossRef](#)]
20. Uemoto, Y.; Hikita, M.; Ueno, H.; Matsuo, H.; Ishida, H.; Yanagihara, M.; Ueda, T.; Tanaka, T.; Ueda, D. Gate Injection Transistor (GIT)—A Normally-Off AlGaIn/GaN Power Transistor Using Conductivity Modulation. *IEEE Trans. Electron Devices* **2007**, *54*, 3393–3399. [[CrossRef](#)]
21. Cittanti, D.; Vico, E.; Bojoi, I.R. New FOM-Based Performance Evaluation of 600/650 V SiC and GaN Semiconductors for Next-Generation EV Drives. *IEEE Access* **2022**, *10*, 51693–51707. [[CrossRef](#)]
22. Huang, X.; Liu, Z.; Li, Q.; Lee, F.C. Evaluation and Application of 600 V GaN HEMT in Cascode Structure. *IEEE Trans. Power Electron.* **2014**, *29*, 2453–2461. [[CrossRef](#)]
23. Lidow, A. (Ed.) *GaN Power Devices and Applications*; John Wiley & Sons Ltd.: Hoboken, NJ, USA, 2021; ISBN 0996649220.
24. Musumeci, S.; Armando, E.; Mandrile, F.; Scrimizzi, F.; Longo, G.; Mistretta, C. Experimental Evaluation of an Enhanced GaN-Based Non-Symmetric Switching Leg Integrated Module for Synchronous Buck Converter Applications. In Proceedings of the 2021 23rd European Conference on Power Electronics and Applications (EPE'21 ECCE Europe), Ghent, Belgium, 6–10 September 2021; pp. 1–10. [[CrossRef](#)]
25. EPC2152 Datasheet and Application Note. Available online: <https://epc-co.com/epc/products/gan-fets-and-ics/epc2152> (accessed on 5 April 2023).
26. Musumeci, S.; Mandrile, F.; Barba, V.; Palma, M. Low-Voltage GaN FETs in Motor Control Application; Issues and Advantages: A Review. *Energies* **2021**, *14*, 6378. [[CrossRef](#)]
27. Cambridge GaN Devices CGD65A055S2 Datasheet. Available online: [https://cms.camgandevices.com/uploads/CGD\\_65\\_A055\\_S2\\_8f7276942a.pdf](https://cms.camgandevices.com/uploads/CGD_65_A055_S2_8f7276942a.pdf) (accessed on 5 April 2023).
28. Direct-Drive Configuration for GaN Devices. Available online: <https://www.ti.com/lit/wp/slpy008a/slpy008a.pdf?ts=1680655995471> (accessed on 5 April 2023).
29. MASTERGAN1 High Power Density 600V Half-Bridge Driver with Two Enhancement-Mode GaN HEMT. Available online: <https://www.st.com/resource/en/datasheet/mastergan1.pdf> (accessed on 5 April 2023).
30. Musumeci, S.; Panizza, M.; Stella, F.; Perraud, F. Monolithic Bidirectional Switch Based on GaN Gate Injection Transistors. In Proceedings of the 2020 IEEE 29th International Symposium on Industrial Electronics (ISIE), Delft, The Netherlands, 17–19 June 2020; pp. 1045–1050. [[CrossRef](#)]
31. GaN Power ICs. Available online: <https://navitassemi.com/gan-power-ics/> (accessed on 5 April 2023).
32. Doumergue, P.-L.; Bontemps, S. First 650V 60A GaN Power Module in a Compact, Package. In Proceedings of the PCIM Europe 2022, International Exhibition and Conference for Power Electronics, Intelligent Motion, Renewable Energy and Energy Management, Nuremberg, Germany, 10–12 May 2022; pp. 1–8. [[CrossRef](#)]

33. Musumeci, S.; Palma, M.; Mandrile, F.; Barba, V. Low-Voltage GaN Based Inverter for Power Steering Application. In Proceedings of the 2021 AEIT International Conference on Electrical and Electronic Technologies for Automotive (AEIT AUTOMOTIVE), Torino, Italy, 17–19 November 2021; pp. 1–6. [[CrossRef](#)]
34. Mishra, D.; Arora, V.; Nguyen, L.; Iriguchi, S.; Sada, H.; Clemente, L.; Spencer, S. Packaging Innovations for High Voltage (HV) GaN Technology. In Proceedings of the 2017 IEEE 67th Electronic Components and Technology Conference (ECTC), Orlando, FL, USA, 30 May–2 June 2017; pp. 1480–1484. [[CrossRef](#)]
35. Prado, E.O.; Bolsi, P.C.; Sartori, H.C.; Pinheiro, J.R. An Overview about Si, Superjunction, SiC and GaN Power MOSFET Technologies in Power Electronics Applications. *Energies* **2022**, *15*, 5244. [[CrossRef](#)]
36. Das, M.; Bertilsson, K. GaN Based Converters for Battery Charging Application of Electric Vehicle. In Proceedings of the IECON 2019—45th Annual Conference of the IEEE Industrial Electronics Society, Lisbon, Portugal, 14–17 October 2019; pp. 5134–5139. [[CrossRef](#)]
37. Stubbe, T.; Mallwitz, R.; Rupp, R.; Pozzovivo, G.; Bergner, W.; Haeberlen, O.; Kunze, M. GaN Power Semiconductors for PV Inverter Applications—Opportunities and Risks. In Proceedings of the CIPS 2014, 8th International Conference on Integrated Power Electronics Systems, Nuremberg, Germany, 25–27 February 2014; pp. 1–6.
38. Power Brick. Available online: <https://www.sunpower-uk.com/glossary/power-brick/> (accessed on 5 April 2023).
39. Mauroicale, G.; Raciti, A.; Rizzo, S.A.; Susinni, G.; Fusillo, F.; Palermo, A.; Scrimizzi, F. Efficiency of state-of-the-art GaN devices in a synchronous-rectifier buck converter. In Proceedings of the IECON 2019—45th Annual Conference of the IEEE Industrial Electronics Society, Lisbon, Portugal, 14–17 October 2019; pp. 1726–1731. [[CrossRef](#)]
40. Armando, E.; Fusillo, F.; Musumeci, S.; Scrimizzi, F. Low Voltage Trench-Gate MOSFETs for High Efficiency Auxiliary Power Supply Applications. In Proceedings of the 2019 International Conference on Clean Electrical Power (ICCEP), Otranto, Italy, 2–4 July 2019; pp. 165–170. [[CrossRef](#)]
41. Han, D.; Sarlioglu, B. Deadtime Effect on GaN-Based Synchronous Boost Converter and Analytical Model for Optimal Deadtime Selection. *IEEE Trans. Power Electron.* **2016**, *31*, 601–612. [[CrossRef](#)]
42. Mortazavizadeh, S.A.; Palazzo, S.; Amendola, A.; De Santis, E.; Di Ruzza, D.; Panariello, G.; Sanseverino, A.; Velardi, F.; Busatto, G. High Frequency, High Efficiency, and High Power Density GaN-Based LLC Resonant Converter: State-of-the-Art and Perspectives. *Appl. Sci.* **2021**, *11*, 11350. [[CrossRef](#)]
43. Choi, J.; Tsukiyama, D.; Tsuruda, Y.; Rivas, J. 13.56 MHz 1.3 kW resonant converter with GaN FET for wireless power transfer. In Proceedings of the 2015 IEEE Wireless Power Transfer Conference (WPTC), Boulder, CO, USA, 13–15 May 2015; pp. 1–4. [[CrossRef](#)]
44. Faraci, G.; Rizzo, S.A.; Schembra, G. Unmanned aerial vehicles and wind generation serving isolated areas. In Proceedings of the 2020 International Symposium on Power Electronics, Electrical Drives, Automation and Motion (SPEEDAM), Sorrento, Italy, 24–26 June 2020; pp. 138–143. [[CrossRef](#)]
45. Barba, V.; Solimene, L.; Palma, M.; Musumeci, S.; Ragusa, C.S.; Bojoi, R. Modelling and Experimental Validation of GaN Based Power Converter for LED Driver. In Proceedings of the 2022 IEEE International Conference on Environment and Electrical Engineering and 2022 IEEE Industrial and Commercial Power Systems Europe (EEEIC/I&CPS Europe), Prague, Czech Republic, 28 June–1 July 2022; pp. 1–6. [[CrossRef](#)]
46. Alharbi, S.S.; Alharbi, S.S.; Matin, M. Effects of Gallium Nitride (GaN) Cascode FETs on the Efficiency of an Interleaved DC-DC Converter. In Proceedings of the 2018 IEEE International Conference on Electro/Information Technology (EIT), Rochester, MI, USA, 3–5 May 2018; pp. 384–389. [[CrossRef](#)]
47. Raciti, A.; Musumeci, S.; Chimento, F.; Privitera, G. A new thermal model for power MOSFET devices accounting for the behavior in unclamped inductive switching. *Microelectron. Reliab.* **2016**, *58*, 3–11. [[CrossRef](#)]
48. Saito, W.; Naka, T. UIS test of high-voltage GaN-HEMTs with p-type gate structure. *Microelectron. Reliab.* **2016**, *64*, 552–555. [[CrossRef](#)]
49. Li, H.; Li, X.; Wang, X.; Wang, J.; Alsmadi, Y.; Liu, L.; Bala, S. E-mode GaN HEMT short circuit robustness and degradation. In Proceedings of the 2017 IEEE Energy Conversion Congress and Exposition (ECCE), Cincinnati, OH, USA, 1–5 October 2017; pp. 1995–2002. [[CrossRef](#)]
50. Landel, M.; Gautier, C.; Lefebvre, S. Study of short-circuit robustness of p-GaN and cascode transistors. *Microelectron. Reliab.* **2022**, *138*, 114695. [[CrossRef](#)]
51. Barth, C.B.; Assem, P.; Foulkes, T.; Chung, W.H.; Modeer, T.; Lei, Y.; Pilawa-Podgurski, R.C. Design and control of a GaN-based, 13-level, flying capacitor multilevel inverter. In Proceedings of the 2016 IEEE 17th Workshop on Control and Modeling for Power Electronics (COMPEL), Trondheim, Norway, 27–30 June 2016; pp. 1–6. [[CrossRef](#)]
52. Barchowsky, A.; Kozak, J.P.; Grainger, B.M.; Stanchina, W.E.; Reed, G.F. A GaN-based modular multilevel DC-DC converter for high-density anode discharge power modules. In Proceedings of the 2017 IEEE Aerospace Conference, Big Sky, MT, USA, 4–11 March 2017; pp. 1–10. [[CrossRef](#)]
53. Nakayama, Y.; Kanazawa, Y.; Kondo, F.; Inoue, M.; Ohta, K.; Doki, S.; Shiozaki, K. Efficiency Improvement of Motor Drive System by using a GaN Three Phase Inverter. In Proceedings of the 2019 IEEE International Conference on Industrial Technology (ICIT), Melbourne, VIC, Australia, 8 July 2019; pp. 1599–1604. [[CrossRef](#)]
54. Musumeci, S.; Barba, V.; Palma, M. GaN-Based Low-Voltage Inverter for Electric Scooter Drive System. In Proceedings of the 2022 AEIT International Annual Conference (AEIT), Rome, Italy, 3–5 October 2022; pp. 1–6. [[CrossRef](#)]

55. Ermolaev, A.; Erofeev, V.; Plekhov, A.; Titov, D. Magnetic Vibration in Induction Motor Caused by Supply Voltage Distortion. *Energies* **2022**, *15*, 9600. [[CrossRef](#)]
56. Mandrile, F.; Musumeci, S.; Palma, M. Dead Time Management in GaN Based Three-Phase Motor Drives. In Proceedings of the 2021 23rd European Conference on Power Electronics and Applications (EPE'21 ECCE Europe), Ghent, Belgium, 6–10 September 2021; pp. 1–10. [[CrossRef](#)]
57. Musumeci, S.; Barba, V.; Mandrile, F.; Palma, M.; Bojoi, R.I. Dead Time Reverse Conduction Investigation in GaN-Based Inverter for Motor Drives. In Proceedings of the IECON 2022—48th Annual Conference of the IEEE Industrial Electronics Society, Brussels, Belgium, 17–20 October 2022; pp. 1–6. [[CrossRef](#)]
58. Uğur, M.; Keysan, O. Multi-physics design optimisation of a GaN-based integrated modular motor drive system. *J. Eng.* **2019**, *2019*, 3900–3905. [[CrossRef](#)]
59. EPC21601data Sheet. Available online: <https://epc-co.com/epc/products/gan-fets-and-ics/epc21601> (accessed on 5 April 2023).
60. Xiao, M.; Ma, Y.; Du, Z.; Pathirana, V.; Cheng, K.; Xie, A.; Zhang, Y. Multi-Channel Monolithic-Cascode HEMT (MC2-HEMT): A New GaN Power Switch up to 10 kV. In Proceedings of the 2021 IEEE International Electron Devices Meeting (IEDM), San Francisco, CA, USA, 9 March 2022; pp. 5.5.1–5.5.4. [[CrossRef](#)]
61. Barba, V.; Musumeci, S.; Palma, M.; Bojoi, R. Maximum Peak Current and Junction-to-ambient Delta-temperature Investigation in GaN FETs Parallel Connection. *Power Electron. Devices Compon.* **2023**, *5*, 100035. [[CrossRef](#)]
62. Wattenberg, M.; Lorenz, O.; Sanchez, J. Efficiently Paralleling GaN-Transistors for High Current and High Frequency Applications Using a Butterfly Layout. In Proceedings of the 2022 24th European Conference on Power Electronics and Applications (EPE'22 ECCE Europe), Hanover, Germany, 5–9 September 2022; pp. 1–10.

**Disclaimer/Publisher's Note:** The statements, opinions and data contained in all publications are solely those of the individual author(s) and contributor(s) and not of MDPI and/or the editor(s). MDPI and/or the editor(s) disclaim responsibility for any injury to people or property resulting from any ideas, methods, instructions or products referred to in the content.