

Exploiting the generative design potential to select the best conceptual design of an aerospace component to be produced by additive manufacturing

Original

Exploiting the generative design potential to select the best conceptual design of an aerospace component to be produced by additive manufacturing / Pilagatti, Adriano Nicola; Atzeni, Eleonora; Salmi, Alessandro. - In: INTERNATIONAL JOURNAL, ADVANCED MANUFACTURING TECHNOLOGY. - ISSN 0268-3768. - ELETTRONICO. - 126:(2023), pp. 5597-5612. [10.1007/s00170-023-11259-7]

Availability:

This version is available at: 11583/2979589 since: 2023-06-26T12:43:51Z

Publisher:

Springer

Published

DOI:10.1007/s00170-023-11259-7

Terms of use:

This article is made available under terms and conditions as specified in the corresponding bibliographic description in the repository

Publisher copyright

(Article begins on next page)



Exploiting the generative design potential to select the best conceptual design of an aerospace component to be produced by additive manufacturing

Adriano Nicola Pilagatti¹ · Eleonora Atzeni¹ · Alessandro Salmi¹

Received: 30 November 2022 / Accepted: 11 March 2023 / Published online: 5 May 2023
© The Author(s) 2023

Abstract

Since the advent of Industry 4.0, the manufacturing sector has had to face new challenges, which require the development of new skills and innovative tools. This scenario includes innovative production processes such as additive manufacturing (AM), a technology capable of producing a component layer-by-layer directly from the 3D model without needing specific tools during the building phase. Generative design (GD) may represent an opportunity to maximise the potential of AM techniques. GD is based on parametric computer-aided design (CAD) tools capable of generating multiple optimised outputs, among which the designer could select the most promising solution. This paper presents a general methodology for evaluating the GD outputs in the conceptual phase of design to select the best possible solution through a series of criteria at several levels. The evaluation method is deployed in an aerospace field case study. The procedure demonstrates the benefits of synergising GD with AM in the early stages of product development. This indicates that the developed methodology could reduce the number of iterations during the design process, and the result is a decrease in the overall time spent on the project, avoiding problems during the final stages of the design.

Keywords Additive manufacturing · Generative design · Design methodology · Laser-powder bed fusion

1 Introduction

Production moved from craft manufacturing to more current mass customisation during the industrial revolutions. This was obtained through intermediate stages where the production was conditioned by continually growing and more revolutionary models, more adaptable to new needs, and has been subject to preferring a *pull* strategy rather than a *push* one [1]. The adoption of the pull strategy foresees a series of changes in the way a company approaches the market: shorter development times, identification of demand in quantitative and qualitative terms, flexibility, decentralisation of production, and resource efficiency [2]. With the advent of the Fourth Industrial Revolution and the digitalisation of production (Industry 4.0), the manufacturing sector has to

face new challenges, which require developing new skills and using innovative tools. This scenario includes smart factories and particularly the use of innovative production systems such as additive manufacturing (AM) [3–5].

In agreement with various authors, AM is a set of technologies capable of producing a component layer-by-layer directly from its three-dimensional model without requiring specific tools and in a single production step during the building phase [6, 7]. AM characteristic layer-wise production claims several advantages, such as the ability to produce complex and highly lightened shapes, thus minimising the buy-to-fly ratio [8]. The aerospace sector is the one that makes the most of AM techniques potential. The primary objective of the aerospace industry is to reduce the overall mass of the aircraft while improving the part performance, even at the risk of higher production costs [9]. Reducing the overall mass of the aircraft can make it fly farther and faster and consume less fuel. In addition, the aerospace industry can take advantage of AM to reduce environmental impact, reducing greenhouse gas emissions [10]. In the attempt to make this possible, the various parts of the aircraft should be lighter, but care should be taken not to affect other structural

✉ Adriano Nicola Pilagatti
adriano.pilagatti@polito.it

¹ Department of Management and Production Engineering (DIGEP), Politecnico di Torino, Corso Duca degli Abruzzi 24, 10129 Torino, Italy

requirements such as stiffness, fatigue strength, and resistance to high temperatures [11]. For these reasons, the aerospace industry has always been very attentive to the search for new materials, such as superalloys or composite materials, and to the use of innovative production techniques, such as AM [7]. Moreover, the aerospace industry could take advantage of numerous AM studies; for example, the directed energy deposition (DED) family technique allows control of the component properties of narrow regions to optimise its characteristics and extend its service life [9, 12, 13]. In particular, DED techniques enable the production of functionally graded materials, optimising the parts thanks to the different thermo-mechanical properties of the materials used in the metallic junction [4, 14–16]. Furthermore, in the aerospace sector, each structural component adopted on the aircraft must pass the two most critical phases: qualification and product certification. Thanks to the constant increase in the reliability of AM techniques, it is now possible to standardise the qualification and certification process of the components produced by AM following current regulations. GE estimates that AM will be exploited to build future ships that can safely transport humans to the Moon and Mars and has already started the fuel nozzle tip mass production for jet engines [17, 18]. Even if building an entire spaceship by AM is a utopian statement that could happen in the long-term future, to date, we are able to build sustainable eco-houses using AM [19].

Intending to take advantage of the adoption of AM technologies, the design of the components plays a key role. Nowadays, AM metal techniques produce final high-performance components with complex shapes, freeing the design from the process limits of standard techniques (e.g. milling, turning, foundry, and bending). Since the cost of a component made for AM does not depend on its complexity but rather on the amount of material used and its size, it can be said that the products made for AM are *complexity for free* [7]. To be more precise, gaps and challenges in materials, supports, process optimisation, and post-processing must be achieved before AM becomes truly complex for free or less costly [20]. As a result, geometric complexity is no longer a constraint for component design, and design optimisation tools can be exploited efficiently. Topology optimisation (TO) and generative design (GD) are two effective tools available to the designer for component optimisation. As a matter of fact, the very complex shapes generated by TO and GD, often not producible by conventional processing techniques, now have a production potential [21]. These tools can both be used to define an initial concept from which to develop an increasingly detailed design in the later stages of the design. Also, TO plays a significant role in optimising obsolete components in terms of performance and can therefore be optimised by adopting different materials or production processes than the original one. TO is used in various

fields, from the automotive, aerospace, and medical sectors to design and architecture. On the other hand, GD has found its main place in the design of buildings and, therefore, in the field of architecture and design [22]. In more recent years, the GD has also been used in the engineering field, particularly the structural one, thanks to the development and implementation of commercial software [23, 24].

As concerns GD, it is a conceptual project support to the designer based on a parametric computer-aided design (CAD), capable of generating multiple output proposals, which can be achieved by more than one production techniques [25]. The core of GD is to apply an evolutionary algorithm to populate alternative solutions in the design space [26]. Such algorithms optimise solutions by taking into account overall structural characteristics, material properties, and process constraints. In addition, GD algorithms may use both evolutionary design (EV) and TO but are not limited to the use of only one of these [27]. Although there is no precise and consistent definition of what GD is, it can be said that “generative design systems are aimed at creating new design processes that produce spatially novel yet efficient and buildable designs through the exploitation of current computing and manufacturing capabilities” [28], so it can help engineers think like designers and vice versa as assessed by Kazi et al. [29]. However, it should be noted that the distinction between the two approaches is sometimes unclear as TO algorithms could be also used in GD. On the other hand, GD offers a range of outputs that meet the designer’s requirements, thus allowing him to use multiple approaches to solve a problem. Typically, the choice of the right solution in the design process is based on the personal judgement of the designer.

GD allows taking into account some of the aspects of production already in the conceptual phase by integrating aspects such as finite element method (FEM) analysis, manufacturing limits and advantages, and production costs. This integration positively impacts the design process since potential issues are anticipated, and risk is reduced. This design approach for product development allows designers to evaluate performance in advance, partly avoiding the costly testing phase [30]. The methodology embraces the concurrent engineering approach, where the development of a project is integrated into its manufacturing, and the duration of the product development cycle could be reduced by up to 70% [31].

This work adopts a *simulation-driven* method based on GD software, aiming to define a methodology to quickly select the most promising solution from a portfolio of solutions, cutting down the time spent in the design phase. The proposed approach is intended for conceptual design and allows various geometries to be analysed and ranked and the best one to be quickly identified from the perspective of product functionality, costs, and

production aspects. It opens the way to the next steps of preliminary and final designs. More in detail, the methodology is applied to AM as manufacturing technology and aerospace as an application sector.

2 The design process

The design process includes several phases that are usually supported by specialised tools. The typical phases of the design process are presented, and the tools covered by this study are detailed in the following paragraphs.

2.1 Phases of the design process

The design of a product is typically developed in three phases: concept, definition, and development.

Concept phase. The first phase is the conceptual design and involves exploring the possible solutions applicable to the case study. During the design of an industrial product, Dorst and Cross [32] argue that the creative component is essential. As far as the conceptual prototyping part is concerned, using specific design software is not strictly required: it can be carried out iteratively by sketching on a piece of paper or digital drawing [22, 33, 34]. Using techniques such as brainstorming and *brainsketching* could be very efficient. However, this approach requires some conditions often unavailable to the designer: working teams and extended development times [35]. In this regard, the availability of a design tool such as three-dimensional modelling software could help the individual designer overcome the limits due to the time and the lack of development teams.

Definition phase. The second phase of the development of a product consists in realising the preliminary design of the component. Using CAD software, the three-dimensional model is created following the conceptual design developed in the previous phase. It is a crucial operation as it allows the designer to visualise the component, to fit the part into the assembly, and, sometimes, by using a CAD software tool that foresees it, to analyse the relative movements. This type of analysis makes it possible to verify the component correct functioning by ensuring that there is no interference with the other components and that it correctly fulfils the required function [36].

Development phase. The final phase is the final design of the component, which is a resume of the first two phases. Computer-aided engineering (CAE) analyses are performed based on the CAD model to highlight any engineering issues, like structural and thermal ones, and, if required, to perform optimisations [37]. In this step, the designer adapts and improves the CAD model based on the emerging

problems and designs the component with technical details, also considering the production process. The application of optimisation techniques could improve the structural performance of the component [38].

According to a *design-driven* method, product development follows a top-down sequential workflow. The main limit of the *design-driven* method lies in the structural problems that may arise in the advanced phases of the project when the product topology has already been defined, as a substantial number of working hours were employed to develop it. Differently, in a *simulation-driven* method (Fig. 1), optimisation techniques are already applied in the first conceptual phase of the project allowing to obtain an advanced design concept.

This method can prevent problems from occurring at the most advanced design stages. This alternative design method requires the CAD/CAE concurrent modelling, the definition of the loads, and the constraints that are more precise than usual in the concept phase and only sometimes available when starting a project. In the other hand, in most cases, it makes it possible to eliminate several iterations during the design process, shortening the project time.

2.2 Generative design software tools for the simulation-driven method

In the conceptual phase of the design, suitable solutions shall be explored without breaching design and manufacturing constraints, and GD could help and guide the designer early in the creative process typical of divergent thinking [39]. However, in the early stages of the design, these potentialities could be supported with the method proposed in this work by considering the technical possibilities of realising such products and increasing the intrinsic value of the GD. In this way, the designs developed are certainly producible through the current state-of-the-art AM techniques. Prior work has documented the effectiveness of GD in improving design exploration and product performance at the early stages of the product design process; Dino [40], for example, reports the efficacy of using a GD tool in architecture design exploration. Moreover, Krish [22] showed how GD through CAD could offer a wide variety of solutions to choose from in the early stages of a project. In fact, the use of CAD in

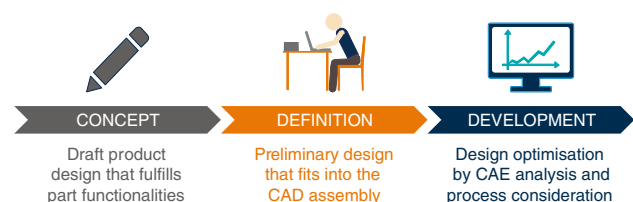

Fig. 1 The workflow of the *simulation-driven* method

the preliminary phases offers more leeway than its targeted use exclusively in the final phase of the project since, at this point, the possible modifications are limited. Another possible use of GD is related to the implementing automotive related designs, as proposed by Burnap et al. [41]. Bagassi et al. [27] confirmed the GD potential in the aeronautical sector and proposed a robust design procedure. In this respect, Tyflopoulos et al. [42] claimed the limitations of commonly used tools for optimisation and how an integrated procedure between CAD and FEA can deliver better results in optimisation, reducing human errors.

Several GD techniques are proposed in the literature, including shape grammars, L-systems, cellular automata, swarm intelligence, and genetic algorithms. Most developed GD systems are a natural evolution of the mentioned techniques [43]. Autodesk proposes a distinction between five methods suitable for AM: TO, lattice and surface optimisation, form synthesis, and trabecular structures [44]. TO is one of the best-known techniques to find, if existing, the optimal structure from a starting design space while complying with the boundary conditions and domain restrictions [45]. Lattice and surface optimisation methods consist of repeating a cellular unit structure, like crystalline ones, filling the parts of a component to be lightened [46, 47]. Form synthesis collects all these techniques, such as size and form optimisation [48]. These, and TO, are the three macro-categories of engineering optimisation issues. Finally, trabecular structures are mainly used in the medical field and create porous structures, often pseudo-randomly generated. These consist of rods connected, with a surface roughness obtained through AM and bio-medical materials, allowing implantation in patients [49]. When reference is made to a specific application sector (e.g. mechanical design), starting from developing a product up to its design and from design to its production, we can identify two macro-categories of GD: additive methods and subtractive methods. Lobos [44] explained the two approaches of GD (i.e. subtractive and additive methods) and how they are applied to a product design, evaluating the integrated method for production using AM techniques that also consider aesthetic beauty. GD, therefore, is a technique that lends itself to a *simulation-driven* method of design as it can create continuous structures meeting the demands of the problem without the need to define a volume (also known as design space) from which to remove the least efficient structural material.

An example of how GD can be used to develop mechanical components was proposed by Bagassi et al. [27], where the first part of the method focuses on a divergent phase, which explores various concept designs, followed by a convergent phase, in which the correct solution is sought. In the last few years, many GD software tools were released either as a part of CAE or as a stand-alone application. In larger companies developing engineering software, an increasingly

common trend is integrating CAD software with CAE ones. In this way, the working environment does not change, and the designer can focus on developing a product in its preliminary stages. Table 1 summarises some GD commercial software and their potential, paying particular attention to those suitable for GD, TO, and design for additive manufacturing (DfAM) [50].

The potential of GD software tools is maximised if AM techniques are selected for production and vice versa. Briard et al. [51] implemented a GD approach in the AM field, suggesting a workflow and a score-based evaluation method. They observed that GD outputs often have bio-inspired shapes, asymmetric, with variable thicknesses, and are often challenging to produce if not with AM techniques. Moreover, Wang et al. [52] evaluated by a CAE analysis the two lightest outputs generated by the GD software for a complex shape joint case study. They produced the conceptual prototype by fused deposition modelling (FDM) and a scaled mock-up part by laser powder bed fusion (L-PBF). In addition, AM techniques in synergy with GD offer higher efficiency and possibilities and can exploit human collaboration through data exchanged on cloud in an Industry 4.0 scenario [53]. In this perspective, several engineering software developers have focused their efforts to create platforms that allow design in a cloud-based collaborative environment for product lifecycle management (PLM) optimisation. Among software developers, we can mention PTC, Autodesk, and Dassault Systèmes and their respective cloud platforms: PTC PLM Cloud, Autodesk Vault, and 3DEXPERIENCE. These tools aim to enable large companies, which interface with the future through Industry 4.0, to use a tool that can combine PLM and design on CAD in such a way as to optimise the product design and life management of a product [54].

3 Methodology

The methodology proposed by the authors involves the use of a GD software tool to generate a variety of outputs suitable for AM production. The outputs proposed by GD software require a study capable of generating a series of performance and economic evaluations to be subsequently submitted to the designer's interpretation, as assessed by Briard et al. [51]. Typically, the outputs must respect the limits imposed by the designer and meet the requirements of different types: fatigue resistance, thermal dissipation, and minimum factor of safety (FoS). The evaluation procedure proposed in this paper focuses on four steps, which are (i) GD optimisation, (ii) scoring and sorting algorithm, (iii) manufacturing assessment, and (iv) performance evaluation, and allows to select a single output among those generated by GD software. The workflow of the proposed methodology is shown in Fig. 2. In particular, the sequence of operations and evaluation steps

Table 1 GD-AM software commercially available

Software name	Company	Multi-Objective	Fluid study	Lattice	Support generator	Process simulation	Platform packing	Post processing	Material prediction
3DXpert	3D Systems Inc.			✓	✓	✓	✓		
3-matic	Materialise		✓	✓					
Ansys Additive Suite	Ansys Inc.			✓	✓	✓			✓
Creo	PTC						✓		
Fusion 360 / Netfabb	Autodesk Inc.		✓	✓	✓	✓	✓		
Inspire Print3D	Altair Engineering Inc.			✓	✓		✓		
MSC Apex GD	Hexagon AB			✓			✓		
nTopology	nTopology Inc.	✓		✓			✓		
NX	Siemens			✓	✓		✓	✓	
Solidworks	Dassault Systèmes			✓			✓		
Solid Edge	PTC			✓	✓		✓		

allows a quick general estimation of the problems that may arise at any level of product development. These include non-compliance with manufacturability and technical requirements or excessively high production costs and times. Furthermore, the proposed decision-making scheme does not impact the GD characteristics and technique.

Starting from an initial idea of the component (named *part concept* in the following) and its general production characteristics that are the maximum envelope, the batch size, and the minimum production rate (PR) required, the possibility to produce the part concept with a feasible AM production system is preliminarily assessed. Thereafter, the design based on the *simulation-driven* method begins with the definition of the 3D CAD models of the geometries that limit the allowable volume for the part design: the designer thus creates the so-called *fixed volume* and *obstacle geometry* [25].

3.1 Generative design optimisation

Exploiting GD software, the inputs are the boundary conditions (BCs), the loads, adopting proper approximations to simplify the analysis, the optimisation objectives, and constraints, but also materials and manufacturing constraints have to be implemented in the GD optimisation. After the finite element (FE) model set-up, the optimisation is launched, performed, and could produce k solutions, $GD(k)$, if existing, that fulfil the GD inputs requirements.

3.2 Scoring and sorting algorithm

The evaluation of the $GD(k)$ solutions is carried out through a selection scoring and sorting algorithm to organise the outputs in a $GD(i^{th})$ k -length vector assessing specific criteria [55] or weighted criteria as claimed by Pilagatti et al. [56]. This algorithm aims to obtain an ordered vector based on the performance of the various outputs, according to the designer’s objective or multi-objective.

3.3 Manufacturing assessment

Subsequently, the manufacturing assessment starts with the first ranked GD output, $GD(1^{st})$. Suppose the manufacturing constraints introduced by the GD optimisation have specific parameters for the building orientation of the component in the machine. In that case, this orientation shall be maintained in all subsequent phases, as shown in Fig. 2. Thereafter, if the $GD(1^{st})$ output is oriented in the reference system according to $GD(1^{st})$ manufacturing constraints, the PR of the $GD(1^{st})$ output is evaluated: copies of the oriented $GD(1^{st})$ output are positioned and packed on the construction platform in such a way as to maximise the number of pieces that can be produced in a single job. This way, optimisation constraints are tighter than those of packing to maximise productivity and cannot be

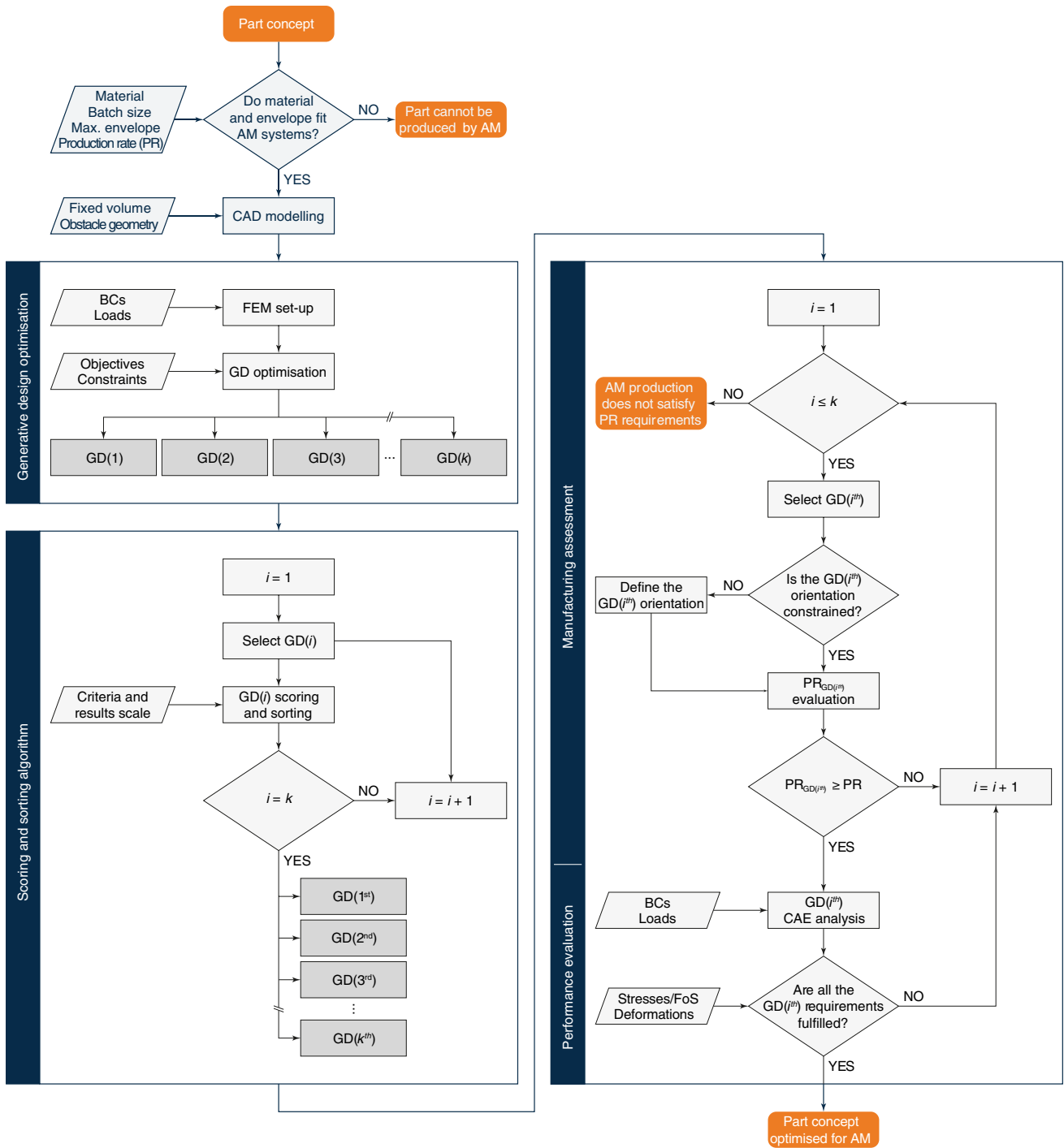

Fig. 2 Workflow proposed for the evaluation of the outputs generated from the software GD

breached. At this point, considering the job time, the $PR_{GD}(1^{st})$ is calculated as the number of components produced in a unit period of time. On the other hand, if there are no imposed orientation constraints in the GD phase, the $GD(1^{st})$ output is oriented to maximise nesting efficiency and productivity, and $PR_{GD}(1^{st})$ is evaluated as described above. It is worth to note that all the produced components must have the same

orientation in the machine in order to meet the qualification criteria typical of the aerospace sector [57]. If the $PR_{GD}(1^{st})$ does not meet the required PR, the $GD(1^{st})$ output is discarded. Then the evaluation is repeated on the following $GD(i^{th})$ outputs until a feasible solution, if existing, is reached [58]. The manufacturing assessment is taken before the detailed structural analysis that is highly labour and time-consuming.

3.4 Performance evaluation

A CAE analysis is performed on the feasible GD(i^{th}) solution by removing the approximations adopted in the GD optimisation phase. This detailed analysis is needed to verify that the solution meets all the design requirements, including residual stresses, deformation, and FoS. If the requirements are not completely satisfied, a new iteration starts for the GD($i^{\text{th}} + 1$) output. Finally, the output is prototyped after the evaluation is completed, and the solution is accepted. If approved, the output will be selected for the subsequent design phases.

There are no guarantees the GD software is capable of generating suitable outputs to be produced with a commercially available AM system. Moreover, the GD optimisation could not find a solution for all the inputs required, if these are too strict.

4 Case study

The proposed methodology has been applied and validated on a case study that refers to an aerospace application. Specifically, an aircraft bearing bracket has been re-designed exploiting AM possibilities. This bracket has the function of supporting sensors mounted on a shaft able to rotate thanks to rolling bearings. The final component shall meet specific company requirements as follows:

- 1.5 mm of maximum deformation
- 2 as a minimum FoS
- $\varnothing 0.6$ mm of position tolerance between the axis of the two-bearing housing in the deformed configuration

Moreover, it must be as light as possible, although this could mean running into additional production costs. The original bracket (shown in Fig. 3) has overall dimensions of $162 \times 116 \times 47$ mm³ and is made of UNI EN AW-7075 (i.e. Ergal), which is a common standard alloy in aerospace, as it shows a good balance between mechanical characteristics and low density [59].

The bracket is fixed to the aircraft and is subjected to six possible acceleration cases, according to the RTCA DO-160G-Environmental Conditions and Test Procedures for Airborne Equipment [60]. A 522 g mass sensor is connected to a 19 mm diameter Ergal shaft; this can rotate around the bracket (y-axis in Fig. 3), both CW and CCW, with the rolling bearings. This could produce two different torques that, combined with the six possible acceleration cases of the aircraft, return a total of twelve load cases.

A small-batch production of 60 pieces [61] and 2 months for delivery are assumed, which correspond to a minimum PR = 7.5 pcs/week. The goal is to identify a lightweight

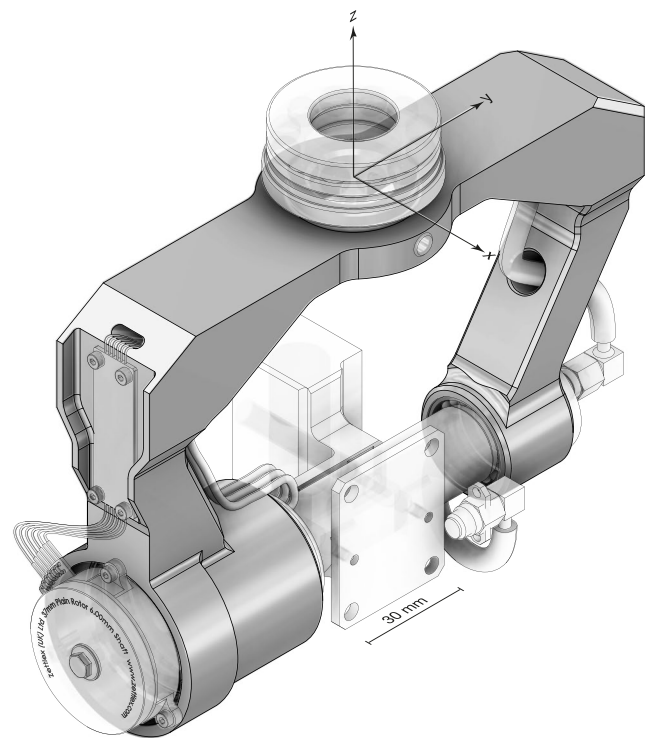

Fig. 3 Original bearing bracket with ancillary parts in transparency

geometry optimised for the product functionality, able to meet AM production requirements and with consideration of also costs.

4.1 AM production feasibility

Currently available AM metal techniques differ in the production process, achievable performance, and application areas. For the component under study, a proper AM technology is the L-PBF, which is well suited for creating small and medium batches of metal components with complex shapes and limited sizes [62]. Moreover, the L-PBF technique is suitable for manufacturing components that have a proper balance between the minimum producible detail level and a good surface finishing [63]. This process involves using a laser to melt metal powders selectively. The powder is deposited and fused in such a way as to form, layer after layer, a completely dense three-dimensional structure [21, 64]. The process characteristics such as layer height (typically between 20 and 100 μm), laser power, scanning strategy, inert gas flow type, and recoating system can vary between companies and are specific to the system considered. The increasing use of the L-PBF technique in aerospace is amply demonstrated by several case studies adopted by large companies in the sector. GE has now produced more than 30,000 LEAP engine fuel nozzles, reducing both the total mass (25% less) and the number of components (from 20 to 1) [65]. The Airbus A350

XWB has been fitted with a titanium alloy bone-like bracket produced by AM, with a total mass reduction of 30% compared to the same component designed and produced using conventional techniques such as foundry or milling [66].

As the original component material (Ergal) is currently unavailable for commercial AM systems, the AlSi10Mg alloy is considered an alternative material in this optimisation study. This choice was due to several reasons, including its proven reliability in the aerospace field and the characteristics of the components produced employing the L-PBF technique. These have similar and, in some cases, superior mechanical properties, compared to the components of the same alloy produced by traditional foundry technologies [67]. Moreover, the use of Ti6Al4V titanium alloy is also explored. In addition to having excellent mechanical properties, it has high corrosion resistance and low density. Ti6Al4V is widely used in the aerospace sector, and AM processes have reduced the buy-to-fly ratio from both economic and environmental impact points of view [68]. For these reasons, this alloy has aroused great interest in research and development.

In order to be able to estimate the criteria of the manufacturing assessment correctly, it is necessary to verify the availability of an AM system supporting the following characteristics:

- A building volume large enough to produce the bracket
- Possibility to process AlSi10Mg and Ti6Al4V
- Capability of meeting productivity requirements (minimum PR) and low downtime between two consecutive jobs

Among commercially available L-PBF machines, the EOS M 400–4 is one of the feasible systems that fulfil all the technical requirements and characteristics for this case study, as detailed in Table 2 [69], and is selected for the case study.

In detail, Table 3 shows the mechanical characteristics of the alloys processed by EOS M 404–4 and the comparison with the original AW-7075 material. Both considered AM alloys require heat treatment after building. In particular, the properties listed in Table 3 refer to samples subjected to the following heat treatments: 90 min of annealing at 270 °C for AlSi10Mg samples and a thermal relaxation at 800 °C for 2 h in an inert atmosphere for Ti6Al4V samples [70]. These are standard treatments for processed products using the L-PBF technique, enabling these components to maximise their mechanical properties.

The following hypotheses are assumed for AM production to evaluate the PR:

- Production in three shifts, 7 days a week
- One hour for pre-setting
- Three hours from the completion to the start of the next job and 1 h to unload the machine
- Production with no discard (ideal)
- One hour per piece for supports removal
- Heat treatment time depending on parts material and size

Table 2 EOS M 400–4 AM system datasheet

Parameter	Value
Building volume	400×400×400 mm ³
Build rate	5,000 mm ³ /h
Recoating time	10 s

Table 3 Mechanical properties of AW-7075 and comparison with AlSi10Mg and Ti6Al4V powder components after heat treatment [70]

Mechanical property	AW-7075	AlSi10Mg ¹	Ti6Al4V ²
Young's modulus (GPa)	71.7	70 ± 10	113.8 ± 10
Poisson's ratio	0.33	0.34	0.34
Density (kg/m ³)	2810	2670	4410
Yield strength (MPa)	145	220 ± 20	945 ± 20
Ultimate tensile strength (MPa)	276	340 ± 20	1055 ± 20

¹Stress relieve: anneal for 2 h at 300 °C (572 °F)

²HT: 800 °C for 2 h in argon inert atmosphere

4.2 Obstacle geometry and fixed volume

In an optimisation study, the volumes excluded must be identified and left unaffected; these volumes define the *non-design space*. This phase is essential as it allows the correct functioning of the component in the assembly and ensures that the couplings are carried out correctly.

The *obstacle geometry* is identified considering the geometry of the assembly that could interfere with the optimised component (Fig. 4). The *obstacle geometry* includes both coupling and relatively moving parts. In the current case, the *obstacle geometries* include (red in Fig. 4):

- Ball bearing aircraft connector
- Sensor system (rotating shaft, ball bearings, motor, and counter mass)
- Electronic components

The volume included in the final design and excluded from the optimisation is called the *fixed volume*. In the current case, the *fixed volumes* include (green in Fig. 4):

- Coupling volume with the aircraft
- Coupling volume with rolling bearings
- Volume for supporting electronic components

Finally, wires of the sensors (blue in Fig. 4) are not considered in the optimisation design, as they are flexible and easily adaptable to the resulting design.

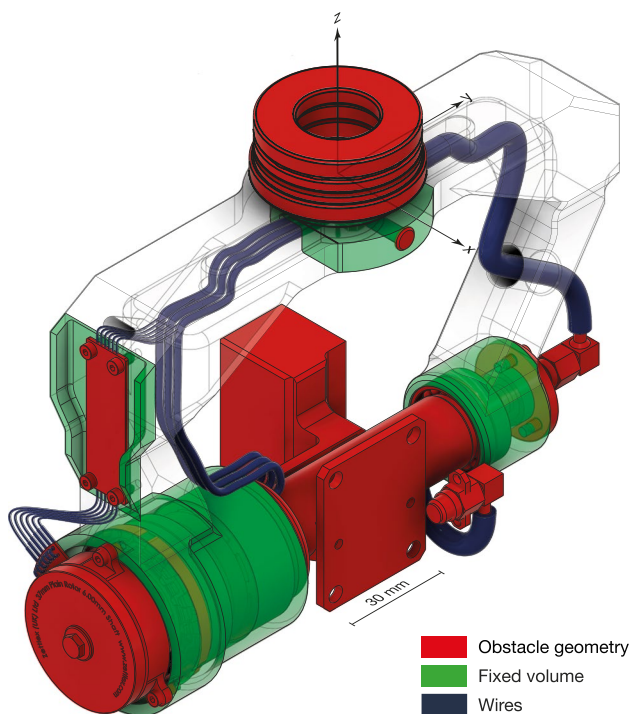

Fig. 4 Fixed volume, obstacle geometry, and wires

4.3 Objective and assumptions of the GD optimisation

In the case study, the optimisation objective is to reduce the mass by constraining the maximum permissible von Mises stress. As outlined in the Introduction, this is the primary focus of the aerospace industry. The L-PBF process introduces some manufacturing constraints that could limit the geometrical complexity of the part. Fusion 360 by Autodesk, i.e. the commercial GD software used in this work for the optimisation, allows to consider the L-PBF constraints or to exclude this limitation from the optimisation; in this study, both approaches have been examined. Specifically, L-PBF manufacturing constraints were defined as the maximum permissible angle to be produced by L-PBF without supporting cantilevered surfaces [71]. The selected values are conservative and have been set to 45° for the AISi10Mg and 35° for the Ti6Al4V.

5 Results and discussion

According to the methodological approach previously described, the final design of the aircraft bracket was identified, starting from various outputs generated by Fusion 360 GD software. The design flow is presented in the following paragraphs.

5.1 GD optimisation

Fusion 360 allows the automation and workflow of some typical finite element modelling processes, making the entire process leaner. Therefore, the Fusion 360 software generates, in a single step, a series of outputs, typical of the GD, that fulfil the demands with an evident saving of time and resources in the first phases of a product development.

The bracket was discretised with 3D linear tetrahedral elements, the only type available on Fusion 360, by an automatic mesh algorithm implemented in the Autodesk software [72]. The shaft was simplified and modelled as a simple linear beam, and the connection between the shaft and the bracket was assumed as parabolic with the bearing load, available on Fusion 360. Finally, all the rotating sensors were simplified as a single point mass, placed in the reduced mass coordinate on the shaft [25], where all the load cases are applied.

Fusion 360 provided 16 outputs from the inputs supplied, displayed, and organised in Fig. 5, as possible concepts of the bracket, 8 of which are in AISi10Mg and 8 in Ti6Al4V alloy. It should be noted that the number of outputs the software provides depends on the materials and the manufacturing constraints. Another distinction must be made on the production constraints as, for each material, two optimisations were unconstrained to the production process while the remaining six accounted for it.

5.2 Scoring and sorting algorithm

The evaluation of the supplied GD(k) outputs is related to the mass and costs of the component. The weight criterion was chosen as input to generate scoring of the selection sort algorithm, and, in this case, the lightest is at the first position with index $i = 1$. The selection sort algorithm is applied to all GD(k) outputs and ranked, as highlighted in Table 4.

It is noticeable that the first outputs appearing in the ranking are unconstrained, as the manufacturing constraints applied do not ensure that the optimisation of the function reaches the global minimum. It is possible to highlight how the titanium alloy components did not meet the main demand, namely the reduction, if any, in mass compared to the original design, except for the GD(13) output which has a mass reduction of around 24%. Moreover, a possible range of production costs for each output was estimated by the aPriori tool implemented in Fusion 360 [25]. From the first estimate of the costs supplied by the cost evaluation tool, it is possible to prove that these are linked to the component volume and not to the geometrical complexity, as claimed by Jared et al. [20].

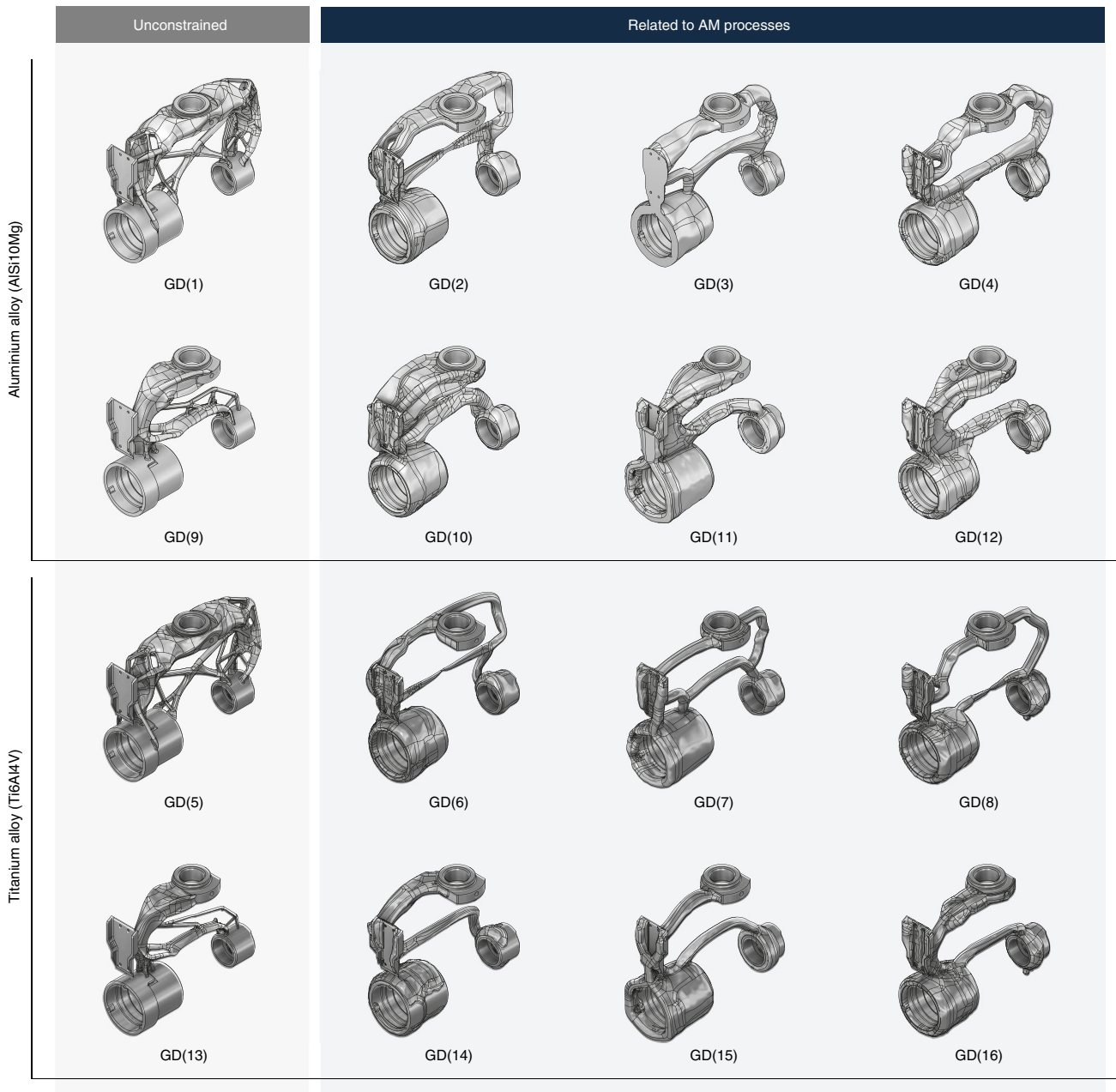

Fig. 5 GD(*k*) outputs

5.3 Manufacturing assessment

The manufacturing assessment was initially performed on the first ranked GD(1st) output, shown in Fig. 6, to characterise the output from the production perspective. This analysis was performed on Autodesk Netfabb Premium software. The assessment was carried out considering (i) the volume of material needed for the part, (ii) the volume and areas of supports, and (iii) the building time of a single component.

The L-PBF technique involves the use of supports during the construction of components. Supports play a fundamental role in the success of the job and have multiple functions, including anchoring to the construction platform, the dissipation of excess heat, and supporting structures with an exceeding overhang angle. As a result, the supports reduce residual stresses and excessive distortions and prevent collapse during manufacture [71, 73, 74]. On the other hand, supports are a source of material waste, in addition to the time needed for their

Table 4 Results of the scoring and sorting algorithm

GD(<i>i</i> th) sorted output	GD(<i>k</i>) output	Material	Orientation	Unit cost (EUR/part)	Mass (g)	Mass variation
1 st	9	AlSi10Mg	Unconstrained	110–186	186	–41.9%
2 nd	1	AlSi10Mg	Unconstrained	130–235	225	–29.7%
3 th	13	Ti6Al4V	Unconstrained	630–760	243	–24.1%
4 th	4	AlSi10Mg	AM (Z+)	245–275	286	–10.6%
5 th	2	AlSi10Mg	AM (X+)	235–350	294	–8.1%
6 th	3	AlSi10Mg	AM (Y+)	280–370	295	–7.8%
7 th	12	AlSi10Mg	AM (Z+)	165–260	302	–5.6%
8 th	11	AlSi10Mg	AM (Y+)	140–230	333	+5.6%
9 th	10	AlSi10Mg	AM (X+)	195–290	339	+5.9%
10 th	5	Ti6Al4V	Unconstrained	725–885	363	+13.4%
11 th	16	Ti6Al4V	AM (Z+)	880–1020	381	+19.1%
12 th	8	Ti6Al4V	AM (Z+)	1040–1180	382	+19.45%
13 th	14	Ti6Al4V	AM (X+)	960–1115	390	+21.9%
14 th	6	Ti6Al4V	AM (X+)	1250–1410	398	+24.4%
15 th	7	Ti6Al4V	AM (Y+)	1190–1350	428	+33.8%
16 th	15	Ti6Al4V	AM (Y+)	735–895	431	+34.7%

construction and time spent in post-production for their removal [75]. This results in an increase in production costs that are allocated to the single component. Therefore, one of the goals of the designer is to reduce the massive use of supports by adopting the guidelines of

the DfAM and correctly orienting the component in the machine, reducing the surfaces requiring their use and minimising the total volume of raw materials [21]. For the EOS M 400–4 system considered in this study, the used support parameters are listed in Table 5.

The GD(1st) solution, corresponding to the GD(9) output, has no manufacturing constraints; the orientation algorithm was therefore performed by minimising volume supports and the projected area on the build platform, each weighted to balance the difference between volume and areas. In particular, the chosen weights are 0.25 for the projected area and 0.75 for the support volume, as the latter drastically impacts costs. The data analysis was carried out by placing the component centred on the platform and spaced 10 mm above it. Since this phase aims to screen GD outputs, the supports were analysed as automatically generated by the script, without any modification by the designer. In this way, the supports develop vertically and, although not optimised for individual output, provide a first estimate of the production process. The results obtained on the single component in

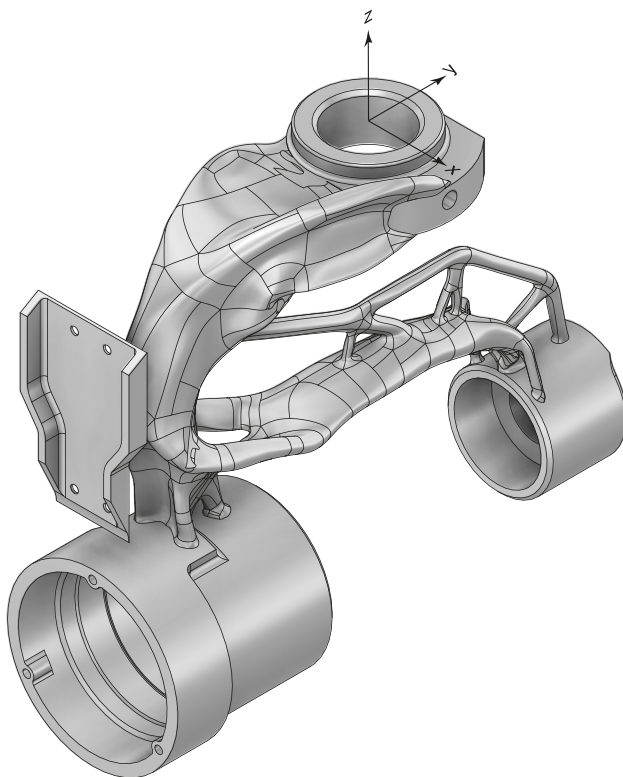

Fig. 6 GD(9) output

Table 5 Support structures parameters script

Support parameter	AlSi10Mg	Ti6Al4V
Support type	Structured	Structured
Structure pattern	Wired wall	Wired wall
Top part connection	Trapoid	Trapoid
Bottom part connection	Trapoid	Trapoid
Platform connection	Strip	Strip
Critical angle (deg)	45	30
Minimal area (mm ²)	10	10

terms of orientation and supports were used to evaluate the maximum number of parts produced for every job.

Particular attention was paid to the packaging of components on the building platform; in fact, the EOS M 400–4 system has areas where the four lasers could overlap, which can lead to problems in the process qualification for the aerospace industry. In particular, these areas create a cross shape on the platform, highlighted in dark red in Fig. 7. Components were thus positioned by excluding that their projection on the platform crosses two adjacent areas. In this way, the components are not produced by overlapping multi-lasers and meet the aerospace industry demand.

Based on the number of parts per job, the minimum number of jobs needed was computed to meet the production requirement of 60 components. *AlSi10Mg_080_HiProM404* standard process parameters were adopted to evaluate the building time [76]. Furthermore, an 80 μm layer height was considered for the aluminium alloy.

Thus, the PR was computed, considering the initial assumptions of the production system (working shifts, unloading, machine time) and heat treatment cycle time, as reported in Table 3. As highlighted in Table 6, the GD(1st) solution showed feasible PR and was selected for the next evaluation step.

5.4 Performance evaluation

The performance evaluation step consists of the CAE analysis performed through the commercial finite element software Altair HyperWorks X and OptiStruct. This software is chosen because it allows defining the mesh and the model manually in a much more detailed and controlled way than Fusion 360. The procedure involved the geometry import



Fig. 7 EOS M 400–4 building platform for GD(1st) output (top view dimensions are $400 \times 400 \text{ mm}^2$)

and meshing of the GD(9) output and, subsequently, the application of loads and constraints, as described in the Case study section. Concerning the discretisation of the model, the bracket was meshed with 3D linear tetrahedral elements (Tetra4), constrained with a fixed support. The shaft was modelled with 1D linear elements (Beam), and the connection between the shaft and the bracket was made possible with the rigid element (RBE2). The latter can transfer only the shaft displacements to the support and consequently the loads. The other parts are assumed as a point mass and connected to the shaft with RBE3 elements with 6 DoF, which can also transfer the torque [77]. Linear static analysis was performed paying particular attention to the worst of the twelve load cases.

In particular, the deformations (displayed in Fig. 8), the maximum von Mises stress, the FoS at yield strength, and the displacement of the two bearings axis were considered, both in terms of position and angle in order to obtain the position tolerance, as visible in Table 7. The rolling bearing chosen for this study (i.e., deep groove ball bearings) can accommodate the angular misalignment between the shaft and the housing [78]. It should be specified that the largest bearing housing was considered as the datum feature.

It is evident from the results that the GD(9) output has the best mass, is producible with a feasible PR, and satisfies the mechanical requirements according to the proposed evaluation method. These considerations imply the choice of this model as an input for the following stages of product design workflow.

6 Conclusions

The problem addressed in this paper is how to exploit the potential of GD software combined with AM technique capabilities to obtain an optimised design already in the first phases of the design process. One of the critical issues in modern production is the adoption of smart factories,

Table 6 GD(1st) solution L-PBF process data estimation

Property	Value
Mass	186 g
Part orientation	Min(support volume + support area)
Support volume per piece	6790 mm^3
Build Height	174.9 mm
Build time per job	182.9 h
Max. parts per built	12
Jobs required	5
Total building time	914.4 h
PR	11 pcs/week

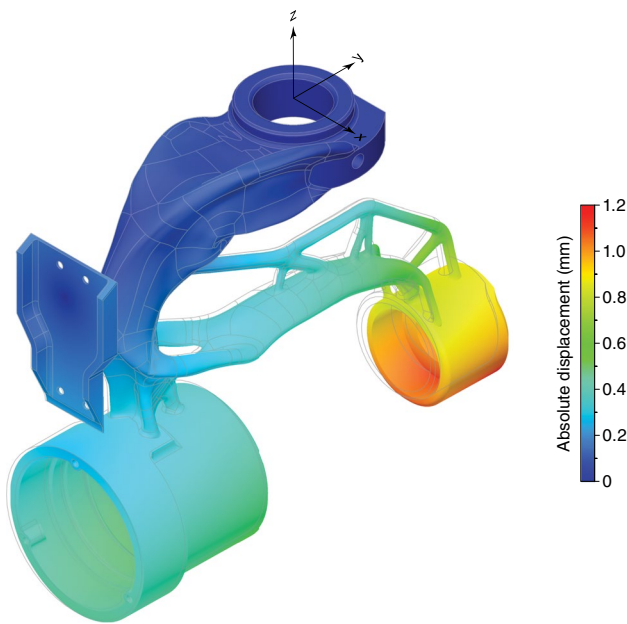

Fig. 8 GD(9) output displacements for the Load case 2

Table 7 Linear static analysis results for the Load case 2

Constraint	Required	GD(9) output
Max displacement (mm)	1.5	1.2
Max von Mises stress (MPa)	110	86.8
Min FoS	2	2.5
Axis position tolerance (mm)	∅0.6	∅0.4

which aims at sustainability by optimising both development and production times. In this context, AM has proven to be competitive both in terms of flexibility and engineering. AM techniques can produce components optimised by high-level algorithms, such as the ones used in GD, with higher intrinsic value than conventional manufacturing processes.

In this study, an evaluation methodology has been proposed based on multi-step criteria that guide the designer selecting the most promising design from the variety of the GD outputs. An aerospace case study was selected to validate the proposed methodology and the evaluation method allowed to choose the design solution among the various GD outputs, which best balances technical performance and AM production aspects. The results confirmed that the procedure adopted is fast and effective, allowing the final solution to be selected without needing an extensive analysis of all the GD outputs. The solution was produced to test the proof of concept in the first conceptual design phase.

Most notably, this is the first study to the author’s knowledge on the effectiveness of implementing an evaluation method for GD tool in AM environment for the conceptual design. The outcomes of the study have provided compelling evidence for adopting GD potentiality in support of the designer creativity process. The results obtained are encouraging; in fact, the GD is well suited to the current manufacturing environment, which is in continuous development and growth.

However, some limitations are worth noting. Although the proposed method is valid for the AM sector, this has not been proven for other production techniques. Moreover, the variety of outputs heavily depends on software algorithms. Also, the results were tested for the linear static case and not for fatigue or nonlinear ones. Therefore, future work should include other GD software or algorithms and evaluate the outputs in more complex cases like high-cycle fatigue analysis to improve the methodology proposed.

Moreover, it should be noted that the proposed methodology is highly dependent on the scoring and sorting criteria. The latter is crucial in selecting the best output, and multiple factors could be considered in a multi-objective evaluation (Pareto frontier) to overcome this limitation [79]. Indeed, adopting different criteria can help achieve different results than this study. The choice of such criteria depends on the designer’s discretion and experience and could be the subject of future investigations. Further development will be implementing the evaluation method by coding an automatic script to select the best GD output, reducing the selection procedure time.

Acknowledgements The Elettronica Aster S.p.A (Barlassina, Italy) company is kindly acknowledged, and Simona Chiarandini and Matteo Facchetti in particular for the support provided in the analysis.

Author contribution A.N. Pilagatti: investigation, methodology, writing—original draft; E. Atzeni: formal analysis, writing—review and editing, resources; A. Salmi: visualisation, resources, writing—review and editing.

Funding Open access funding provided by Politecnico di Torino within the CRUI-CARE Agreement. This research was partially supported by the Interdepartmental Center for Integrated Additive Manufacturing (IAM@PoliTo) at the Politecnico di Torino (Italy).

Data availability The manuscript has no associated data. Data will be made available upon request.

Declarations

Ethical approval Not applicable.

Consent to participate Not applicable.

Consent for publication Not applicable.

Competing interests The authors declare no competing interests.

Open Access This article is licensed under a Creative Commons Attribution 4.0 International License, which permits use, sharing, adaptation, distribution and reproduction in any medium or format, as long as you give appropriate credit to the original author(s) and the source, provide a link to the Creative Commons licence, and indicate if changes were made. The images or other third party material in this article are included in the article's Creative Commons licence, unless indicated otherwise in a credit line to the material. If material is not included in the article's Creative Commons licence and your intended use is not permitted by statutory regulation or exceeds the permitted use, you will need to obtain permission directly from the copyright holder. To view a copy of this licence, visit <http://creativecommons.org/licenses/by/4.0/>.

References

- Wang Y, Ma HS, Yang JH, Wang KS (2017) Industry 4.0: a way from mass customization to mass personalization production. *Adv Manufac* 5(4):311–320. <https://doi.org/10.1007/s40436-017-0204-7>
- Lasi H, Fettke P, Kemper HG, Feld T, Hoffmann M (2014) Industry 4.0. *Bus Inform Syst Eng+* 6(4):239–242. <https://doi.org/10.1007/s12599-014-0334-4>
- Li B, Wang L, Wang B, Li D, Oliveira JP, Cui R, Yu J, Luo L, Chen R, Su Y, Guo J, Fu H (2022) Electron beam freeform fabrication of NiTi shape memory alloys: crystallography, martensitic transformation, and functional response. *Mater Sci Eng: A* 843:143135. <https://doi.org/10.1016/j.msea.2022.143135>
- Bevans B, Ramalho A, Smoqi Z, Gaikwad A, Santos TG, Rao P, Oliveira JP (2023) Monitoring and flaw detection during wire-based directed energy deposition using in-situ acoustic sensing and wavelet graph signal analysis. *Mater Des* 225:111480. <https://doi.org/10.1016/j.matdes.2022.111480>
- Zuo X, Zhang W, Chen Y, Oliveira JP, Zeng Z, Li Y, Luo Z, Ao S (2022) Wire-based directed energy deposition of NiTiTa shape memory alloys: Microstructure, phase transformation, electrochemistry, X-ray visibility and mechanical properties. *Additive Manufacturing* 59:103–115. <https://doi.org/10.1016/j.addma.2022.103115>
- Atzeni E, Salmi A (2012) Economics of additive manufacturing for end-usable metal parts. *Int J Adv Manuf Tech* 62(9–12):1147–1155. <https://doi.org/10.1007/s00170-011-3878-1>
- Gibson I, Rosen D, Stucker B (2015) *Additive manufacturing technologies*, 2nd edn. Springer, New York. <https://doi.org/10.1007/978-1-4939-2113-3>
- Barnes J, Kingsbury A, Bono E (2016) Does low cost titanium powder yield low cost titanium parts. In: PowderMet 2016 international conference on powder metallurgy. Boston
- Milewski JO (2017) *Additive manufacturing of metals*. Springer Ser Mater Sci. <https://doi.org/10.1007/978-3-319-58205-4>
- Priarone P, Lunetto V, Atzeni E, Salmi A (2018) Laser powder bed fusion (L-PBF) additive manufacturing: on the correlation between design choices and process sustainability. *Procedia CIRP* 78:85–90. <https://doi.org/10.1016/j.procir.2018.09.058>
- Immarigeon JP, Holt RT, Koul AK, Zhao L, Wallace W, Beddoes JC (1995) Lightweight materials for aircraft applications. *Mater Charact* 35(1):41–67. [https://doi.org/10.1016/1044-5803\(95\)00066-6](https://doi.org/10.1016/1044-5803(95)00066-6)
- Rodrigues TA, Escobar JD, Shen J, Duarte VR, Ribamar GG, Avila JA, Maawad E, Schell N, Santos TG, Oliveira JP (2021) Effect of heat treatments on 316 stainless steel parts fabricated by wire and arc additive manufacturing: microstructure and synchrotron X-ray diffraction analysis. *Additive Manufacturing* 48:102428. <https://doi.org/10.1016/j.addma.2021.102428>
- Piscopo G, Iuliano L (2022) Current research and industrial application of laser powder directed energy deposition. *Int J Adv Manuf Tech* 119(11–12):6893–6917. <https://doi.org/10.1007/s00170-021-08596-w>
- Piscopo G, Atzeni E, Saboori A, Salmi A (2023) An overview of the process mechanisms in the laser powder directed energy deposition. *Applied Sciences (Switzerland)* 13(1):117. <https://doi.org/10.3390/app13010117>
- Rodrigues TA, Cipriano Farias FW, Zhang K, Shamsolhodaei A, Shen J, Zhou N, Schell N, Capek J, Polatidis E, Santos TG, Oliveira JP (2022) Wire and arc additive manufacturing of 316L stainless steel/Inconel 625 functionally graded material: development and characterization. *J Market Res* 21:237–251. <https://doi.org/10.1016/j.jmrt.2022.08.169>
- Makarenko KI, Shishkovsky IV (2020) Direct energy deposition of Cu-Fe system functionally graded structures. *IOP Conference Series: Materials Science and Engineering*. <https://doi.org/10.1088/1757-899X/969/1/012104>
- General Electric Company (2022) Aerospace. <https://www.ge.com/research/sectors/aerospace>. Accessed 23 Mar 2022
- General Electric Company (2018) Transformation in 3D: how a walnut-sized part changed the way GE aviation builds jet engines. <https://www.ge.com/news/reports/transformation-3d-walnut-sized-part-changed-way-ge-aviation-builds-jet-engines>. Accessed 17 Nov 2022
- Bianchini R (2022) 3D-printed house in Italy is made from locally-sourced clay. <https://www.inexhibit.com/case-studies/sustainable-house-in-italy-is-made-by-3d-printing-locally-sourced-clay/>. Accessed 13 Feb 2023
- Jared BH, Aguilo MA, Beghini LL, Boyce BL, Clark BW, Cook A, Kaehr BJ, Robbins J (2017) Additive manufacturing: toward holistic design. *Scripta Mater* 135:141–147. <https://doi.org/10.1016/j.scriptamat.2017.02.029>
- Salmi A, Calignano F, Galati M, Atzeni E (2018) An integrated design methodology for components produced by laser powder bed fusion (L-PBF) process. *Virtual and Physical Prototyping* 13(3):191–202. <https://doi.org/10.1080/17452759.2018.1442229>
- Krish S (2011) A practical generative design method. *Comput Aided Design* 43(1):88–100. <https://doi.org/10.1016/j.cad.2010.09.009>
- Plocher J, Panesar A (2019) Review on design and structural optimisation in additive manufacturing: towards next-generation lightweight structures. *Mater Des* 183:108–164. <https://doi.org/10.1016/j.matdes.2019.108164>
- All3DP (2022) The best generative design software of 2022. <https://all3dp.com/1/the-best-generative-design-software-of-2022/>. Accessed 17 Nov 2022
- Autodesk Inc (2022) Product documentation. <https://help.autodesk.com/view/fusion360/ENU/?guid=GUID-4EB16696-8951-47BC-8F15-10E614D8994F>. Accessed 5 July 2022
- Zhang Y, Wang Z, Zhang Y, Gomes S, Bernard A (2020) Bio-inspired generative design for support structure generation and optimization in additive manufacturing (AM). *CIRP Ann* 69(1):117–120. <https://doi.org/10.1016/j.cirp.2020.04.091>
- Bagassi S, Lucchi F, De Crescenzo F, Persiani F (2016) Generative design: advanced design optimization processes for aeronautical applications. In: 30th Congress of the International Council of the Aeronautical Sciences, ICAS 2016
- Shea K, Aish R, Gourtovaia M (2005) Towards integrated performance-driven generative design tools. *Autom Constr* 14(2):253–264. <https://doi.org/10.1016/j.autcon.2004.07.002>
- Kazi RH, Grossman T, Cheong H, Hashemi A, Fitzmaurice G DreamSketch (2017) Early stage 3D design explorations with sketching and generative design. In: UIST 2017 - Proceedings of

- the 30th Annual ACM Symposium on User Interface Software and Technology. Association for Computing Machinery 401–414. <https://doi.org/10.1145/3126594.3126662>
30. Karlberg M, Löfstrand M, Sandberg S, Lundin M (2013) State of the art in simulation-driven design. *Int J of Product Development* 18:68–87. <https://doi.org/10.1504/IJPD.2013.052166>
 31. Groover M (2016) *Automation, production systems and computer integrated manufacturing*. Pearson, London
 32. Dorst K, Cross N (2001) Creativity in the design process: co-evolution of problem–solution. *Des Stud* 22(5):425–437. [https://doi.org/10.1016/S0142-694X\(01\)00009-6](https://doi.org/10.1016/S0142-694X(01)00009-6)
 33. Greenberg S, Carpendale S, Marquardt N, Buxton B (2012) *Sketching user experiences: The workbook*. Morgan Kaufmann, Boston. <https://doi.org/10.1016/B978-0-12-381959-8.50001-8>
 34. Bacus J (2020) *Digital sketching*. Computer-aided conceptual design. JohnWiley and Sons, Hoboken
 35. Van Der Lugt R (2002) Brainsketching and how it differs from brainstorming. *Creat Innov Manag* 11(1):43–54. <https://doi.org/10.1111/1467-8691.00235>
 36. Dassault Systèmes SolidWorks Corp. (2020) *Understanding Motion Simulation*. https://www.solidworks.com/sw/images/content/Training/SIM_Motion_UnderstandingMotion_WP_ENG.pdf. Accessed 5 July 2022
 37. Pilagatti AN, Piscopo G, Atzeni E, Iuliano L, Salmi A (2021) Design of additive manufactured passive heat sinks for electronics. *J Manuf Process* 64:878–888. <https://doi.org/10.1016/j.jmapro.2021.01.035>
 38. Gaynor A, Decker C, Kaste R, Gao T, Mazurek A, Baker W (2018) Experimentally-informed topology optimization of Michell/Prager structures. In: IASS 2018, pp 1–8
 39. Jia W, Zeng Y (2021) EEG signals respond differently to idea generation, idea evolution and evaluation in a loosely controlled creativity experiment. *Sci Rep* 11(1):2119. <https://doi.org/10.1038/s41598-021-81655-0>
 40. Dino IG (2012) Creative design exploration by parametric generative systems in architecture. *METU J Fac Archit* 29(1):207–224. <https://doi.org/10.4305/METUJFA.2012.1.12>
 41. Burnap A, Liu Y, Pan Y, Lee H, Gonzalez R, Papalambros PY (2016) Estimating and exploring the product form design space using deep generative models. In: *Proceedings of the ASME Design Engineering Technical Conference*. <https://doi.org/10.1115/DETC2016-60091>
 42. Tyflopoulos E, Flem DT, Steinert M, Olsen A (2018) State of the art of generative design and topology optimization and potential research needs. *Proceedings of NordDesign: Design in the Era of Digitalization*
 43. Singh V, Gu N (2012) Towards an integrated generative design framework. *Des Stud* 33(2):185–207. <https://doi.org/10.1016/j.destud.2011.06.001>
 44. Lobos A (2018) Finding balance in generative product design. *Proceedings of NordDesign: Design in the Era of Digitalization*
 45. Huang J, Xu S, Ma Y, Liu J (2022) A topology optimization method for hyperelastic porous structures subject to large deformation. *Int J Mech Mater Des* 18(2):289–308. <https://doi.org/10.1007/s10999-021-09576-4>
 46. Maconachie T, Leary M, Lozanovski B, Zhang X, Qian M, Faruque O, Brandt M (2019) SLM lattice structures: properties, performance, applications and challenges. *Mater DeS* 183:108137. <https://doi.org/10.1016/j.matdes.2019.108137>
 47. Zhao M, Li X, Zhang DZ, Zhai W (2023) Design, mechanical properties and optimization of lattice structures with hollow prismatic struts. *Int J Mech Sci* 238:107842. <https://doi.org/10.1016/j.ijmecsci.2022.107842>
 48. Dede T, Ayvaz Y (2015) Combined size and shape optimization of structures with a new meta-heuristic algorithm. *Appl Soft Comput* 28:250–258. <https://doi.org/10.1016/j.asoc.2014.12.007>
 49. Ragone V, Canciani E, Arosio M, Olimpo M, Piras LA, von Degerfeldt MM, Augusti D, D’Ambrosi R, Dellavia C (2020) In vivo osseointegration of a randomized trabecular titanium structure obtained by an additive manufacturing technique. *J Mater Sci - Mater Med* 31(2):17. <https://doi.org/10.1007/s10856-019-6357-0>
 50. Schwaar C (2021) Top design for additive manufacturing (DfAM) software. <https://all3dp.com/1/top-design-for-additive-manufacturing-ing-dfam-software/#ansys-additive-suite>. Accessed 23 Mar 2023
 51. Briard T, Segonds F, Zamariola N (2020) G-DfAM: a methodological proposal of generative design for additive manufacturing in the automotive industry. *Int J Interactive Des Manuf (IJIDeM)* 14(3):875–886. <https://doi.org/10.1007/s12008-020-00669-6>
 52. Wang H, Du W, Zhao Y, Wang Y, Hao R, Yang M (2021) Joints for treelike column structures based on generative design and additive manufacturing. *J Constr Steel Res* 184:106794. <https://doi.org/10.1016/j.jcsr.2021.106794>
 53. Rajala SA (2012) Beyond 2020: preparing engineers for the future. *Proceedings of the IEEE 100(Special Centennial Issue):1376–1383*. <https://doi.org/10.1109/jproc.2012.2190169>
 54. Saorín JL, de la Torre-Cantero J, Melián Díaz D, López-Chao V (2019) Cloud-based collaborative 3D modeling to train engineers for the Industry 4.0. *Applied Sciences* 9(21):4559. <https://doi.org/10.3390/app9214559>
 55. Goyani M, Chharchhodawala M, Mendapara B (2013) Min-max selection sort algorithm -Improved version of selection sort. *Int J Adv Res Comput Sci Softw Eng* 6
 56. Pilagatti AN, Vecchi G, Atzeni E, Iuliano L, Salmi A (2022) Generative design and new designers’ role in the manufacturing industry. *Procedia CIRP* 112:364–369. <https://doi.org/10.1016/j.procir.2022.09.010>
 57. AIA-Aerospace Industries Association (2020) *Recommended guidance for certification of AM component*. <https://www.aia-aerospace.org/report/certification-of-am-component/>. Accessed 5 July 2022
 58. Nahmias S, Olsen TL (2005) *Production and operations analysis*. Waveland Press Inc., Long Grove
 59. Quaglia C, Buselli E, Webster Iii RJ, Valdastrì P, Menciasci A, Dario P (2009) An endoscopic capsule robot: a meso-scale engineering case study. *J Micromech Microeng* 19(10):105007. <https://doi.org/10.1088/0960-1317/19/10/105007>
 60. RTCA (2010) *RTCA DO-160G - Environmental conditions and test procedures for airborne equipment*. https://my.rtca.org/nc_store?search=DO-160. Accessed 5 July 2022
 61. Kalpakjian S, Schmid S, Sekar V (2013) *Manufacturing Engineering and Technology*, sixth edition in SI units. Pearson, London
 62. Ford S, Despeisse M (2016) Additive manufacturing and sustainability: an exploratory study of the advantages and challenges. *J Clean Prod* 137:1573–1587. <https://doi.org/10.1016/j.jclepro.2016.04.150>
 63. Garcia-Colomo A, Wood D, Martina F, Williams S (2020) A comparison framework to support the selection of the best additive manufacturing process for specific aerospace applications. *Int J Rapid Manuf* 9(2–3):194–211. <https://doi.org/10.1504/ijrapidm.2020.10019230>
 64. Calignano F, Galati M, Iuliano L (2019) A metal powder bed fusion process in industry: qualification considerations. *Machines* 7(4). <https://doi.org/10.3390/machines7040072>
 65. General Electric Company (2018) *New manufacturing milestone: 30,000 additive fuel nozzles*. <https://www.ge.com/additive/stories/new-manufacturing-milestone-30000-additive-fuel-nozzles>. Accessed 23 Mar 2023
 66. Liu R, Wang Z, Sparks T, Liou F, Newkirk J (2017) 13 - Aerospace applications of laser additive manufacturing. In: Brandt M (ed) *Laser Additive Manufacturing*. Woodhead Publishing, pp 351–371. <https://doi.org/10.1016/B978-0-08-100433-3.00013-0>
 67. Kempen K, Thijs L, Van Humbeeck J, Kruth JP (2012) Mechanical properties of AlSi10Mg produced by selective laser melting.

- Physics Procedia 39:439–446. <https://doi.org/10.1016/j.phpro.2012.10.059>
68. Brandl E, Palm F, Michailov V, Viehweger B, Leyens C (2011) Mechanical properties of additive manufactured titanium (Ti–6Al–4V) blocks deposited by a solid-state laser and wire. *Mater Des* 32(10):4665–4675. <https://doi.org/10.1016/j.matdes.2011.06.062>
69. EOS GmbH (2022) EOS M 400–4 technical data. <https://www.eos.info/en/additive-manufacturing/3d-printing-metal/eos-metal-systems/eos-m-400-4>. Accessed 23 Mar 2023
70. EOS GmbH (2022) DMLS Metal Materials for EOS 3D printer. <https://www.eos.info/en/additive-manufacturing/3d-printing-metal/dmls-metal-materials>. Accessed 17 Nov 2022
71. Piscopo G, Salmi A, Atzeni E (2019) On the quality of unsupported overhangs produced by laser powder bed fusion. *Int J Manuf Res* 14(2):198–216. <https://doi.org/10.1504/ijmr.2019.100012>
72. Autodesk Inc. (2022) Meshes. <https://help.autodesk.com/view/fusion360/ENU/?guid=GUID-8B876C32-91C7-4E9A-BB30-15F9BD0B229B>. Accessed 23 Mar 2023
73. Calignano F (2014) Design optimization of supports for overhanging structures in aluminum and titanium alloys by selective laser melting. *Mater Des* 64:203–213. <https://doi.org/10.1016/j.matdes.2014.07.043>
74. Salmi A, Piscopo G, Atzeni E, Minetola P, Iuliano L (2018) On the effect of part orientation on stress distribution in AlSi10Mg specimens fabricated by laser powder bed fusion (L-PBF). *Procedia CIRP* 67:191–196. <https://doi.org/10.1016/j.procir.2017.12.198>
75. Piscopo G, Atzeni E, Calignano F, Galati M, Iuliano L, Minetola P, Salmi A (2019) Machining induced residual stresses in AlSi10Mg component produced by laser powder bed fusion (L-PBF). *Procedia CIRP* 79:101–106. <https://doi.org/10.1016/j.procir.2019.02.019>
76. Autodesk Inc. (2021) About Autodesk® Netfabb®. <https://help.autodesk.com/view/NETF/2021/ENU/?guid=GUID-E48353B3-E8BE-4D1C-8C2E-E207DAA32CBE>. Accessed 23 Mar 2023
77. Altair Engineering Inc. (2017) OptiStruct Verification Problems Manual. https://altairuniversity.com/wp-content/uploads/2018/06/OSVPM_201722_v060118.pdf#:~:text=OptiStruct%20verification%20problem%20manual%20contains%20benchmarked%20problems%20that,element%20type%20and%20material%20properties%2C%20results%2C%20and%20references. Accessed 5 July 2022
78. SKF (2018) Rolling bearings. https://www.skf.com/binaries/pub12/Images/0901d196802809de-Rolling-bearings---17000_1-EN_tcm_12-121486.pdf. Accessed 5 July 2022
79. Forejt V, Kwiatkowska M, Parker D Pareto curves for probabilistic model checking. In: *Lecture Notes in Computer Science (including subseries Lecture Notes in Artificial Intelligence and Lecture Notes in Bioinformatics)*, pp 317–332. https://doi.org/10.1007/978-3-642-33386-6_25

Publisher's note Springer Nature remains neutral with regard to jurisdictional claims in published maps and institutional affiliations.