

Programmable SEL Test Monitoring System for Radiation Hardness Assurance

Original

Programmable SEL Test Monitoring System for Radiation Hardness Assurance / Rizzieri, D., Azimi, S., Sterpone, L., DE SIO, C., Borel, T., Gupta, V., Cardi, M.. - (2023), pp. 217-223. (IEEE/IFIP International Conference on Dependable Systems and Networks Porto (PRT) 27 - 30 June 2023) [10.1109/DSN-S58398.2023.00061].

Availability:

This version is available at: 11583/2979319 since: 2023-06-12T09:23:53Z

Publisher:

IEEE

Published

DOI:10.1109/DSN-S58398.2023.00061

Terms of use:

This article is made available under terms and conditions as specified in the corresponding bibliographic description in the repository

Publisher copyright

IEEE postprint/Author's Accepted Manuscript

©2023 IEEE. Personal use of this material is permitted. Permission from IEEE must be obtained for all other uses, in any current or future media, including reprinting/republishing this material for advertising or promotional purposes, creating new collecting works, for resale or lists, or reuse of any copyrighted component of this work in other works.

(Article begins on next page)

Programmable SEL Test Monitoring System for Radiation Hardness Assurance

Daniele Rizzieri
Politecnico di Torino
Turin, Italy
daniele.rizzieri@polito.it
Orcid: 0000-0002-2976-101X

Sarah Azimi
Politecnico di Torino
Turin, Italy
sarah.azimi@polito.it
Orcid: 0000-0002-9169-6140

Luca Sterpone
Politecnico di Torino
Turin, Italy
luca.sterpone@polito.it
Orcid: 0000-0002-3080-2560

Corrado De Sio
Politecnico di Torino
Turin, Italy
corrado.desio@polito.it
Orcid: 0000-0003-4212-3052

Thomas Borel
ESA
Noordwijk, Netherlands
thomas.borel@esa.int
Orcid: 0000-0002-7512-1187

Viyas Gupta
ESA
Noordwijk, Netherlands
viyas.gupta@esa.int
Orcid: 0000-0003-3611-2971

Margherita Cardi
Tyvak International SRL
Turin, Italy
margherita@tyvak.eu

Abstract—In the continued miniaturization of electronic devices, certain advantages in terms of power consumption, performances, and physical area occupation correspond to an increased susceptibility to highly charged radiation particle interactions. Therefore, it is nowadays extremely important to assess Radiation Hardness Assurance (RHA) procedures in order to guarantee that a certain system is suitable to be used in extreme environmental conditions such as deep space. When performing these measurements, the design and development of dedicated fault monitoring systems to be used as support architecture during the radiation tests are heavily time and budget-consuming operations. The present paper describes a programmable Single Event Latch-up (SEL) monitoring system capable of supporting experimenters on the test of several heterogeneous electronic devices ranging from microcontrollers up to individual MOSFETs. The proposed solution has been successfully verified during a heavy-ion radiation test campaign. The experimental results achieved during the radiation test campaigns are described and commented.

Keywords—Radiation, testing, SEL, MPSoC, Zynq7020

I. INTRODUCTION

When operating in a harsh space environment, electronic devices are subject to several stresses including highly charged radiation particle interactions. Depending on the time and location of the particle interaction with the silicon-sensitive substrate of a device, several failure scenarios might occur known as Single Event Effects (SEEs) [1]. Among these effects, one of the most crucial failure modes is represented by Single Event Latch-ups (SEL).

The SEL phenomenon happens in Complimentary Metal-Oxid-Silicon (CMOS) when a low-impedance stable state forms between the power rails which happen due to the interplay of parasitic bipolar junction transistors (BJTs) formed by the CMOS well structure and is caused by minority charge carriers injected into the body terminals of the parasitic BJTs due to the interaction with highly energetic particles. An SEL effect might provoke a rise in current and increasing temperature which may further cause permanent damage to the electronic device such as

a modification of the silicon conduction channels that may induce a permanent modification of the device's functional conditions. Furthermore, these effects may generate alterations of the component package, due to the overcurrent-induced temperature surge [2], therefore the removal of the power supply is the unique approach in all non-directly catastrophic SEL conditions in order to recover the correct device operations.

To ensure that a certain electronic part is sufficiently characterized versus SEL effects, many radiation tests should be performed, aiming at the reproduction of the particle interactions that could originate a Single Event Latch-up in the Device Under Test (DUT). To do so, in dedicated radiation test facilities, heavy ions of different energies and ranges are accelerated and directed toward the part under test, while it is properly biased and forced in well-known operating states.

One of the main challenges of such a testing procedure is monitoring the main current draws of the DUT to avoid its destruction and prevent any permanent damage that could occur as a consequence of radiation-induced faults. While for specific DUT such as MOSFETs, there is a standard guideline for monitoring the occurrence of SEL, for most of the devices, there are no specific and standard procedures for monitoring and protecting the device during irradiation. Therefore, the test engineer is required to propose and implement the test setup with respect to the DUT which might lead to high-cost ad-hoc custom test boards.

This paper proposes a new programmable monitoring test architecture for measuring the current absorption of a device and at the same time, protecting it from overcurrent permanent damage. The main achievement of the proposed solution is the applicability to different types of devices – ranging from FPGAs to power MOSFETs and permitting a fast test sequence in case of testing not one but a heterogeneous set of devices in the same test slot.

Furthermore, the proposed architecture is capable of monitoring and controlling the beam. Therefore, in the case of a catastrophic occurrence of failure, it is able to immediately

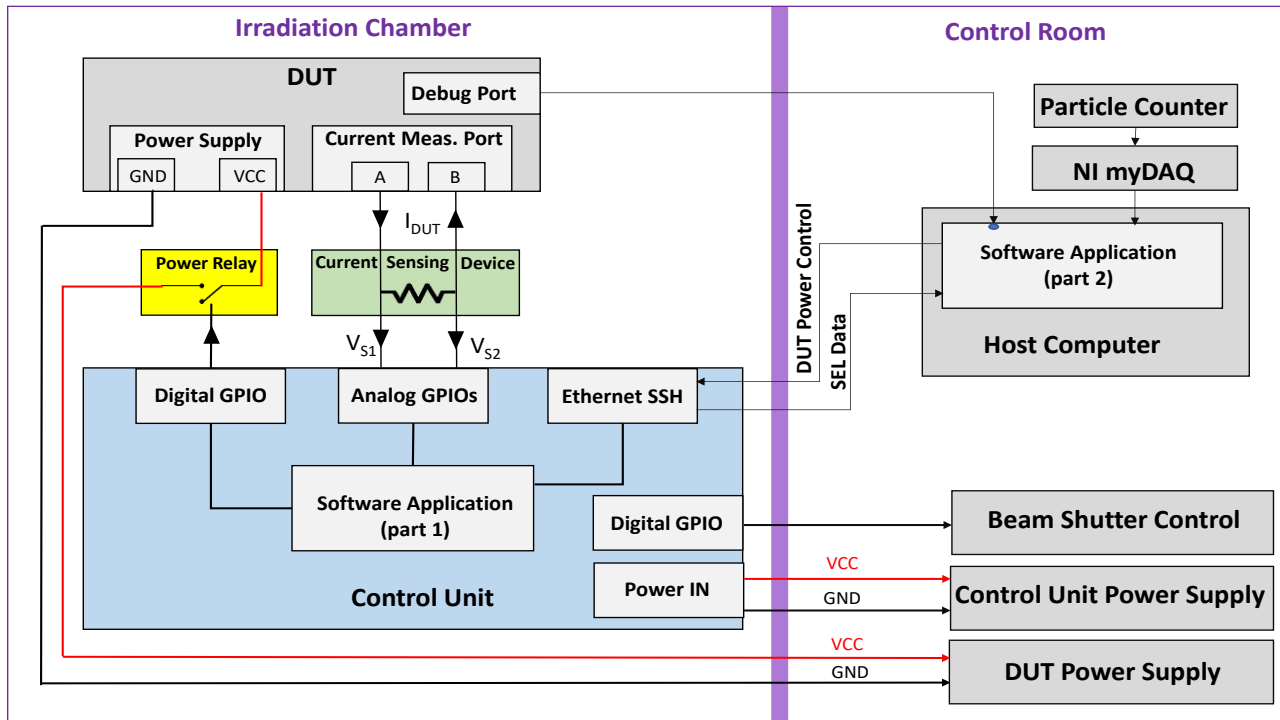

Fig. 1. Hardware setup scheme of the proposed test monitoring system.

suspend the beam flow and effectively count the energetic particles reaching the device. The proposed automatic architecture allows proceeding through the testing sequence while guaranteeing the standard procedure flow. As complementary advantages, the proposed approach allows to maximize the beam time usage enabling the examination of current status and evaluating the occurrences of transient and permanent faults as well. The paper is organized as follows. Section II provides an overview of the recent test platform developed for radiation environments. The developed platform is described in Section III, while experimental results are presented in Section IV. Finally, Section V depicts some conclusions and future works.

II. STATE OF THE ART

An SEL monitoring and testing architecture can be designed and implemented in several different ways, depending on the device under the test. For specific categories of electronic parts, like MOSFETs, standard guidelines describe the required setup to properly stimulate and monitor the DUT during the irradiation with accelerated particles [3]. For other active components, instead, most of the time, no clear standard procedure is present for the SEL simultaneous monitoring and protection of the DUTs, requiring the test engineer to design and implement a proper setup specifically for the purpose. In [4], the authors describe an FPGA anti-SEL power interface protection circuit to be manufactured on a Printed Circuit Board (PCB), without the possibility of easily monitoring and programming parameters like SEL current threshold and implying the need of refactoring part of the circuit for each desired parameter change. Another example of an SEL protection circuit that could be used for this type of radiation testing is described in [5], where the authors exploited a partially fixed electric circuit to disconnect the power supply of the device if an overcurrent condition is detected. Also, in this case, monitoring of the current draw is not

implemented, and a change in the overcurrent threshold requires the refactoring of certain electrical parameters. In [6], [7], [8], and [9], the experimenters used ad-hoc custom test boards embedding FPGA systems for different purposes, achieving not only the monitoring of the latch-ups but also the prevention of permanent damages due to prolonged overcurrent conditions. The drawback of such a solution is the high cost of developing and implementing ad-hoc custom test boards, resulting in a long, complex, and costly design process, not feasible for missions with a limited budget. Another drawback of such a setup is the actual physical space occupation required by it; sometimes, SEL testing is performed in dedicated vacuum chambers which impose limited available space. Therefore, the test setup space occupation can become a critical factor [11]. In the radiation analysis literature, another example of SEL monitoring architecture can be found in [10] in which the authors presented a control structure that exploits a flash-based FPGA to stimulate the DUT and collect the functional results. At the same time, the current absorption of the device under test is measured and logged by dedicated scopes, and external scope monitors are used to manage the incoming data. In this case, one drawback is the need for many separate hardware pieces to achieve the monitoring and the circumvention of Single Event Latch-ups which could be a problem if the irradiation chamber imposes volume or other mounting constraints [20].

The present paper proposes a test setup architecture that allows easy Single Event Latch-up monitoring without the need for expensive equipment and complex ad-hoc electrical circuits, applicable to a wide range of electronic devices. The proposed architecture is based on a commercial off-the-shelf (COTS) Multi-Processor System-On-Chip (MPSoC) and a few low-cost hardware pieces, permitting the modification of several test parameters on-the-fly, without the need for drastic and time-

consuming refactoring of the mounted set up in case a test parameter must be changed.

III. THE PROPOSED PLATFORM

This section is dedicated to elaborating on the proposed architecture for SEL monitoring and measurement. The proposed architecture is based on a commercial COTS- MPSoC, and it is composed of a hardware setup and a distributed software framework, implementing monitoring and circumvention of the latch-ups. The basic working mechanism consists of a control unit that monitors the current absorption of a selected power rail of the DUT. If the measured value trespasses a programmed threshold, the power of the DUT is detached through a physical decoupling device. All the measurements and all the taken actions are recorded in dedicated log files to make the SEL testing experiment even more simple and linear for the test engineer. In the following sections, the hardware and software setups are described in detail.

A. Hardware setup

Figure 1 represents the hardware scheme of the proposed architecture. The main parts needed to implement an SEL monitoring and circumvention system are the following:

- A current sensing device.
- A control unit.
- A physical power supply decoupler.

The main purpose of the developed architecture is the measurement of the current in order to detect the occurrence of SEL and act on it. Therefore, there is a necessity for an accurate but low-cost current measurement system. For the current draw measurement, several low-cost options are available, however, the main techniques are the use of a dedicated current sensor and the use of a simple shunt resistor. The Analog-to-Digital Conversion (ADC) logic inside a current sensor is composed of basic logic gates, and operational amplifiers but possibly also CMOS-based control logic, which could be susceptible to radiation-induced effects and therefore affect the sensing reliability. Furthermore, in such sensors the current is computed based on the voltage drop across an internal fixed shunt resistor [12][13], so another problem is the adaptability of the sensor to the actual current magnitude that has to be measured since a too small (or too high) resistance value would yield to an unfeasible or unreadable measure. Therefore, the proposed architecture exploits the second approach, using a well-known shunt resistor, highlighted in Green in Figure 1, to measure the DUT current as the voltage drop across this passive component. The system presented in this paper aims at being applicable to different DUTs with different electrical characteristics, and the use of an interchangeable shunt resistor best suits the need. In any case, one must take care that the additional resistive load introduced by the shunt resistor is negligible and does not interfere with the rest of the power line towards the DUT. In the system represented in Fig. 1, further described in Section IV the current sensing device has been put directly in series to the main power line since the induced perturbations were negligible.

Talking about the measurement acquisition system, the proposed solution exploits the onboard analog input pins in combination with the base FPGA configuration bitstream –

called *overlay* – that is specifically released by AMD-Xilinx for the MPSoC Programmable Logic (PL) embedded in this board. The provided FPGA configuration implements several Microblaze soft processors to monitor and interact with the onboard hardware peripherals and then provides control to the user application through dedicated Python APIs [14]. As a result, the system is capable of up to 1 mega sample per second (MSPS) over 12 bits, by exploiting the internal hardwired AMD-Xilinx XADC analog-to-digital converter [15][16].

The main hardware components highlighted in blue in Figure 1 are a PYNQ-Z2 development board and an economic COTS SoC which acts as the control unit. This development board allows the execution of a Linux Ubuntu operating system, becoming a complete computing system that can be easily instructed via Ethernet-SSH communication. This operating system is exploited for executing the software application responsible for exchanging the data with the GPIO peripherals and using the Ethernet communication with the experiment host computer.

While the shunt resistor is providing the DUT current level, the onboard analog input pins of the PYNQ COTS SoC are exploited for receiving the analog current signal of the shunt resistor. These input pins of the PYNQ SoC can be used by configuring the programmable logic embedded on the development board and consequently provided to the application software executing on the embedded operating system of the development board in order to detect the

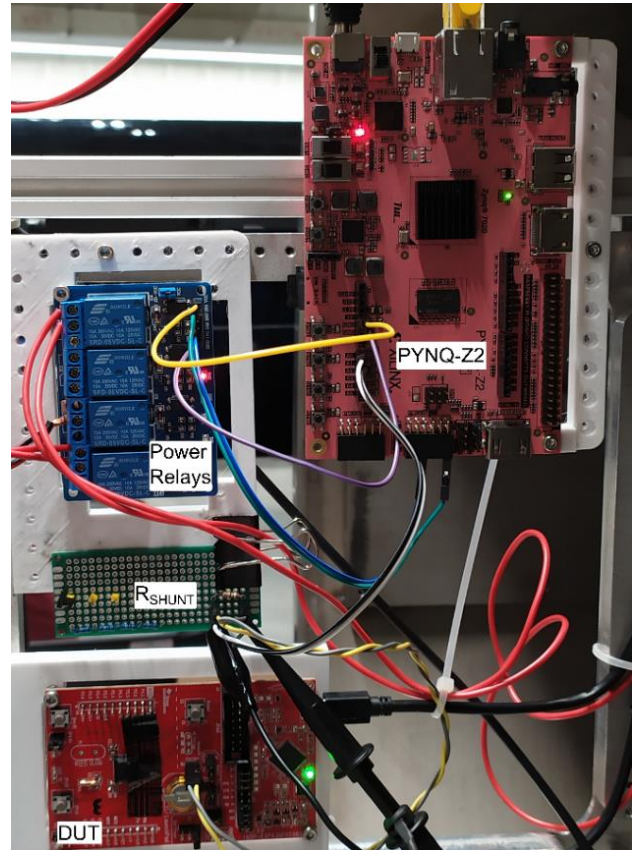

Fig. 2. Photo of the proposed SEL control system mounted at UCL facility

occurrence of the SEL. More information about the software application will be provided in the following.

Once an SEL is detected, the device should be detached from the power supply in order to extinguish any residual current and limit the risk of permanent damage due to the related current surge as much as possible. This action is the duty of the third module, a physical power supply decoupler. There are several possible approaches such as an ad-hoc power MOSFETs control circuit, but due to possible radiation-induced faults – such as Single Event Gate Rupture (SEGR) and Single Event Burnout (SEB) [1], this solution would not be suitable. Therefore, we moved forward with the usage of a power relay module which allows a fast physical detachment of the power supply rail while being aligned with the goal of the proposed architecture, providing a simple and low-cost solution. Practically, in the proposed architecture the relay switch remains normally open, keeping the DUT off. When the irradiation run starts, through a dedicated GPIO signal coming from the control unit the relay switch is closed, powering the DUT. In case an SEL is detected, through the same control unit GPIO signal.

B. Software framework

To complete the monitoring and circumvention of the SEL, a distributed software (SW) control system has been designed and implemented. This SW application is divided into parts. The first part is executed on the embedded operating system of the control unit, physically located in the proximity of the DUT, while the second part is executed on the host computer located in the control room, not at a close distance from the DUT.

On the control board, the following functionalities are implemented:

- DUT current measurement and logging.
- SEL detection and threshold parameters management.
- Autonomous and manual DUT power control, with interface towards host computer.
- Autonomous and manual particle beam control, with interface towards host computer.
- Logging of the experiment events.

The main purpose of the control board is the measurement of the current of the DUT. This is performed as one of the modules of software applications, implemented through dedicated APIs which interface the software with the hardware resources used to achieve the measurement. As mentioned in the previous sections, the current draw of the DUT is obtained as the voltage drop across the shunt resistor. Based on the characteristics of the DUT and the needed sensing resistor, a calibration parameter can be adjusted through SW to precisely adapt the computed value with the actual DUT current draw. Each measured datum is immediately recorded with the corresponding timestamp in a dedicated log file, stored in an onboard flash non-volatile memory (NVM). The software platform is implemented in such a way that these files won't be larger than a certain size – multiple logs are created – permitting the easy retrieval of these data at any time on the experiment host computer, through the Ethernet-SSH connection.

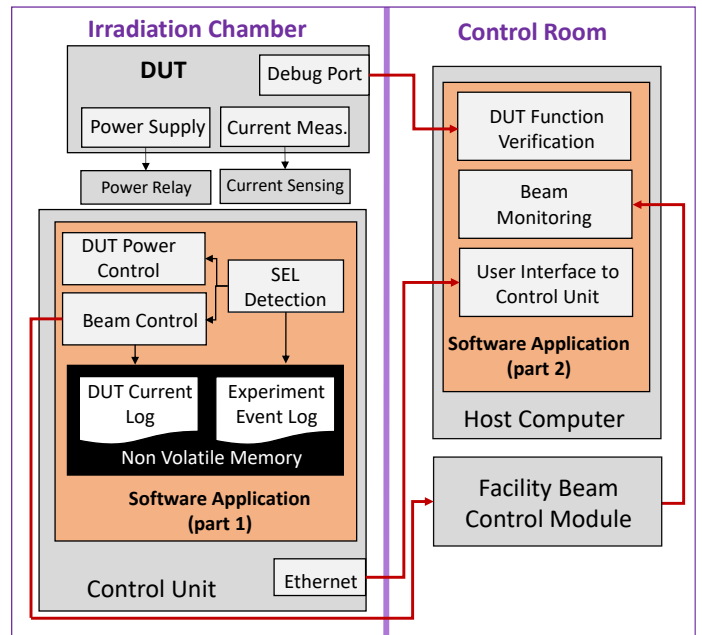

Fig.3. Software framework architectural scheme.

The control board is also responsible for managing the SEL threshold level, the out-of-bound triggering delay, and the moving average window size. Regarding the SEL threshold level, which is the most important parameter to be set, it has to be chosen based on a pre-irradiation characterization of the current signature, because different workload conditions can result in a different current draw behavior. Several other options are considered such as a parameter that can be set to indicate the interval of time for which the DUT current draw must be out-of-bounds before triggering the autonomous cut-off of the device power and the particle beam. The first of these two time interval can be useful to avoid the misdetection of not radiation induced current spikes, erroneously marked as SEL. Another tunable parameter is the interval of time for which, after an SEL is detected, the DUT is kept active while the particle beam is switched off. This is beneficial for checking whether the latch-up can extinguish itself just by avoiding any particle interaction. Optionally, the test engineer can set the number of current measurement samples to be included in a moving average window, to reduce the noise that could be possibly affecting the sensing sub-system.

As mentioned, through two different hardware interfaces, the monitoring unit has the crucial role of autonomously controlling the DUT power and, also the particle beam shutter, when the test facility permits so. In addition to these features, the DUT and beam management actions can also be manually instructed by the experimenter on the experiment host computer, through dedicated commands. During the radiation test, many different events are likely to happen in a short time, and therefore a precise time-related record of such occurrences is very important. For this purpose, a separate log file, keeping track of all the notable events, is progressively written and stored in the onboard NVM of the control board, permitting reconstruction of the sequence of the events that characterized each irradiation run.

The second part of the software application implemented on the experiment host computer is as follows:

- The user interfaces to the test monitoring system.
- Functional verification of the DUT output.
- Beam flux/fluence monitoring.

The main implemented module executed on the host computer is the user interface to the test monitoring system, by using any SSH terminal manager software. The other implemented control services on the host computer – functional verifier and beam flux/fluence monitor – can be used or not depending on the device to be tested, but also according to the characteristics of the test facility in which the procedure is taking place. As said, one implemented function consists of a DUT functional verifier. This can be used to verify the correctness of the DUT output in case the device can produce any digital functional result – i.e., in readable text form, byte-coded, discrete logic levels, etc. The functional verifier can be used with any type of processing unit, ranging from ADC/DACs, and signal processing devices, but also full microprocessors or microcontroller units, as depicted in the architectural scheme of Fig. 1. If the functional output of the DUT is considered as faulty for a certain interval of time, likely, its operation is not nominal and therefore the SEL testing is not valid anymore, since the part could be in an unknown power state, different from the one characterizing the nominal operation. Subsequently, an interrupt message can be sent from the host PC to the monitoring board, to temporarily stop the particle beam and let the test engineer deal with the functional interruption.

Furthermore, another optional feature has been implemented, regarding particle beam monitoring. In fact, if the radiation facility permits so, it can be useful to keep track of how many particles are effectively interacting with the DUT. This value is referred to as *fluence* and it is measured in particles/cm². To retrieve this data, sometimes a dedicated signal is available from the facility dosimetry system. If this is the case, the proposed solution can monitor that signal through any COTS digital acquisition device, like for example the National Instruments myDAQ, which can be easily instrumented and controlled through a set of APIs released as part of the product [17][18]. Nevertheless, the system could be easily adapted to work also with other Data Acquisition (DAQ) systems, without requiring massive SW refactoring.

By exploiting this beam monitoring feature, the overall experiment log produced by the control unit will also include precious data about the actual fluence reached with every

irradiation run. By interacting with the described software architecture, it is possible to achieve a clear view and easy management of the radiation analysis experiment, obtaining also precise and practical experimental results to be analyzed after the test for any further investigations.

IV. EXPERIMENTAL RESULTS

To confirm the efficiency of the proposed architecture, we performed a heavy-ion radiation test campaign at the Heavy ion Facility (HIF) of the Université catholique de Louvain (UCL), Louvain-la-Neuve, Belgium, in July 2022. The purpose of the test was the verification of the device's hardness against radiation-induced Single Event Latch-ups. The test has been conducted in a vacuum irradiation chamber, where accelerated heavy ions have been directed toward the MCU, to possibly trigger latch-up conditions.

TABLE I. HEAVY-ION EXP. PARAMETERS, LET = 32.4 [MEV·CM²/MG]

| DUT Samples | Beam Time [min] | Fluence [particles/cm ²] | | |
|-------------|-----------------|--------------------------------------|----------|----------|
| | | Kr | Rh | Xe |
| #1 | 58 | - | 1,00E+07 | - |
| #2 | 23 | - | - | 2,91E+06 |
| #3 | 62 | - | 1,05E+07 | - |
| #4 | 103 | 1,56E+06 | 1.68E+07 | - |

A. Experiment Setup

The device under test has been the Texas Instruments MSP430FR5969 Microcontroller Unit (MCU), implemented in a Texas Instruments MSP-EXP430FR5969 LaunchPad development kit. Similar devices have been already tested for single event effects, as can be seen in [21] and [22]. The control unit of the proposed architecture is implemented on the PYNQ-Z2 development board by TUL. On this board, many hardware peripherals are integrated around a Zynq-7020 MPSoC by AMD-Xilinx, embedding a programmable logic equivalent to an Artix-7 FPGA together with a 650MHz dual-core Cortex-A9 processor, a 512MB DDR3 memory and a 16MB Quad-SPI Flash memory.

TABLE II. Observed Events for MSP430 Heavy-Ion Experiment

| Sample DUTs | SEL [#] | SEFI [#] | Max DUT Current [A] |
|-------------|---------|----------|---------------------|
| #1 | 2 | 4 | 12.062 mA |
| #2 | 4 | 5 | 22.355 mA |
| #3 | 2 | 7 | 11.696 mA |
| #4 | 1 | 12 | 13.106 mA |

TABLE III. COMPARISON OF FLUENCE OBTAINED FROM THE FACILITY LOGS AND PROPOSED MONITORING AND MEASUREMENT ARCHITECTURE

| DUT Samples | Kr | | Rh | | Xe | |
|-------------|---|--|---|--|---|--|
| | Fluence [particles/cm ²] Facility | Fluence [particles/cm ²] proposed Architecture | Fluence [particles/cm ²] Facility | Fluence [particles/cm ²] proposed Architecture | Fluence [particles/cm ²] Facility | Fluence [particles/cm ²] proposed Architecture |
| #1 | - | - | 1,00E+07 | 9.97E+06 | - | - |
| #2 | - | - | - | - | 2,91E+06 | 2.94E+06 |
| #3 | - | - | 1,05E+07 | 1.03E+07 | - | - |
| #4 | 1,56E+06 | 1.54E+06 | 1.68E+07 | 1.69E+07 | - | - |

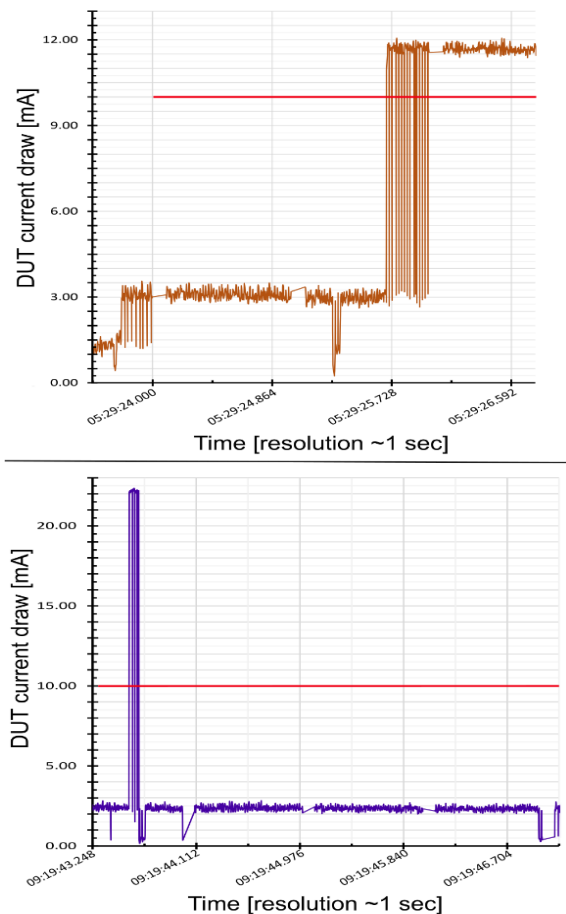

Fig.4. Reconstructed waveforms of two different detected SELs

Many runs have been conducted up to a total fluence of $1.2E+10$ particles/cm². More comprehensive details about the irradiation campaign can be found in Table I where official data coming from the UCL-HIF facility logs are reported. In order to assure the robustness of the DUT against SEL, we tested four different samples of the same device type. Figure 3 represents the test setup which includes the PYNQ-Z2 as the control unit, the power relays, the shunt resistor, and the MSP430 MCU as the DUT.

During the test, both the beam monitoring and the beam shutter control signals, provided by the UCL-HIF facility, were effectively connected to the implemented control system. This allowed us to accurately irradiate the DUTs without overexposing none of the samples, which survived up to the target fluence necessary for robustness assurance.

TABLE II. OBSERVED EVENTS FOR MSP430 HEAVY-ION EXPERIMENT

B. DUT Test Results

During the test experiment, we collected data regarding the number of observed Single Event Latch-up as well as Single Event Functional Interrupts (SEFI). The main difference between an SEL and a SEFI is that the first is referring to an abrupt high current condition affecting the DUT, while the second one is, by definition, an interruption of the nominal function of the device under test, due to particle interaction. Please note that the SEFIs are detected by the DUT functional

verification module of the software application from the host computer and SEL is detected by the SET detection module of the software application from the control unit.

While the nominal current consumption for the DUT is defined as 3 mA, we set the threshold value of SEL equal to 10 mA. Moving forward with the experiment, we increase this value and set it to 40 mA. Please note that thanks to the developed monitoring architecture, this operation was possible without the need of opening the vacuum chamber and not modify the mounted setup.

Table II reports the data obtained during the experiment. While a different number of SEL and SEFI have been observed, thanks to the developed monitoring architecture and fast detachment of the power supply of DUT, none of the events resulted in permanent damage to the sample DUTs. Without an autonomous detachment of the DUT power, some of these events would likely have resulted in permanent damage to the device, denying the possibility of reaching the target fluence and obtaining satisfactory statistical data from the experiment.

C. Monitoring System Performance

As it has been mentioned before, by exploiting the developed proposed monitoring architecture, we were able to detect the occurrence of SEL and SEFI, reported in Table II. Moreover, the developed architecture is capable to obtain information regarding the beam time and fluence of the different sessions automatically. Table III reported the comparison of the Fluence reported by the facility and the obtained by the monitoring platform. As can be observed, there is a negligible difference between the two values. Moreover, by exploiting the measurement recording feature, for each irradiation run a separate log file has been created which allows to precisely reconstruct the waveforms of the DUT current in relation to each of the detected SEL events. Some examples of such waveforms can be seen in Figure 4. In particular, the monitoring system has been capable of measuring and recording 500 samples/s with a resolution of $1\mu A$. The latency between the detection of an SEL and the shutting of the beam, followed by the DUT power cut-off, has been lower than 3ms on average.

I. CONCLUSIONS FUTURE WORKS

This paper is proposing a low-SEL monitoring and circumvention system, capable of being used with different types of CMOS-based devices, which are susceptible to such fault models when operating in the radiation environment. The proposed solution is capable of SEL detection management but also autonomous and manual shutdown of the device and the particle beam. The described hardware and software architecture has been successfully exploited during a heavy-ion radiation test campaign. The results show the accurate current measurement of the proposed architecture, with a resolution of $1\mu A$ and a fast reaction from the detection of SEL until the powering off the DUT, around 3 ms.

II. ACKNOWLEDGEMENTS

This work is part of MILANI project by Tyvak International, financially supported by the European Space Agency (ESA) in the context of the space mission HERA.

REFERENCES

- [1] S. Azimi, B. Du, L. Sterpone, "On the Prediction of Radiation-induced SETs in Flash-based FPGAs", in *Microelectronics Reliability*, 2016, DOI: 10.1016/j.microrel.2016.07.106.
- [2] G. Bruguier and J. M. Palau, "Single particle-induced latch-up," in *IEEE Transactions on Nuclear Science*, 1996, DOI: 10.1109/23.490898.
- [3] Military Specification MIL-STD-750, TEST METHODS FOR SEMICONDUCTOR DEVICES, revision E, Nov 2006.
- [4] G. Yue, W. Shaojun, M. Ning, L. Pan, and P. Yu, "A Single Event Latch-up protection method for SRAM FPGA," 2017 13th IEEE International Conference on Electronic Measurement & Instruments (ICEMI), 2017, pp. 332-336, DOI: 10.1109/ICEMI.2017.8265807.
- [5] S. Kulkarni et al., "A generic, customizable, fault-tolerant load protection system for Small Satellites," 2014 IEEE International Conference on Power Electronics, Drives and Energy Systems (PEDES), 2014, pp. 1-6, DOI: 10.1109/PEDES.2014.7041982.
- [6] B. Crouzat, "AD7961 Heavy Ions Test Report", 2018, Available at: <https://esarad.esa.int/?id=313&handler=DownloadDb>.
- [7] M. Rousselet, "MX30LF4G18AC Heavy Ions Test Report", 2017, Available at: <https://esarad.esa.int/?id=328&handler=DownloadDb>.
- [8] F. X. Guerre, "STP24NF10 Single Event Effects Test Report", 2016, Available at: <https://esarad.esa.int/?id=321&handler=DownloadDb>.
- [9] P. X. Wang, M. Gil, F. Widmer, and P. Garcia, "SEE test results of the LVDS Driver and Receiver," 2013 14th European Conference on Radiation and Its Effects on Components and Systems (RADECS), 2013, pp. 1-4, DOI: 10.1109/RADECS.2013.6937394.
- [10] L. Sterpone, R. Mancini and D. Gelfusa, "Latch-up test measurement for long duration space missions," 2012 IEEE International Instrumentation and Measurement Technology Conference Proceedings, 2012, DOI: 10.1109/I2MTC.2012.6229561.
- [11] S. Azimi, B. Du, L. Sterpone, "Evaluation of Transient Errors in GPGPUs for Safety Critical Application: An Effective Simulation-based Fault Injection Environment", *Journal of Systems Architecture*, vol 75, 2017, DOI: 10.1016/j.sysarc.2017.01.009.
- [12] Texas Instruments, "Current Sense Amplifiers Guide", revision E, 2021, Available at: <https://www.tij.co.jp/jp/lit/slyb194>.
- [13] STMicroelectronics, "Current Sensing Quick Reference Guide", 2022.
- [14] AMD, PYNQ-Z2 Base Overlay documentation webpage, [Online], Available at: <https://pynq.readthedocs.io/en/v3.0.0/>.
- [15] TUL Corporation, "PYNQ-Z2 Reference Manual", version 1.0, 2018,.
- [16] AMD-Xilinx, "7 Series FPGAs and Zynq-7000 SoC XADC Dual 12-Bit 1 MSPS Analog-to-Digital Converter User Guide (UG480)", 2022
- [17] National Instruments, "NI myDAQ User Guide and Specifications", 2011.
- [18] National Instruments, NI-DAQmx Python documentation webpage
- [19] G. Bruguier and J. M. Palau, "Single particle-induced latch-up," in *IEEE Transactions on Nuclear Science*, vol. 43, no. 2, pp. 522-532, April 1996, DOI: 10.1109/23.4908.
- [20] C. De Sio, S. Azimi, L. Sterpone, "Radiation-induced Single Event Transient Effects during the Reconfiguration Process of SRAM-based FPGAs", *Microelectronics -reliability*, 2019, DOI: 10.1016/j.microrel.2019.06.034.
- [21] S. M. Guertin et al., "Radiation Test Results for Common CubeSat Microcontrollers and Microprocessors," *2015 IEEE Radiation Effects Data Workshop (REDW)*, 2015, DOI: 10.1109/REDW.2015.7336730
- [22] J. Aarestad et al., "Single Event Effects Testing of the Hardened Texas Instruments MSP430FR5739 Microcontroller on with Embedded Ferroelectric Memory," *2016 IEEE Radiation Effects Data Workshop (REDW)*, 2016, DOI: 10.1109/NSREC.2016.789174