

H-Bridge Converter as Basic Switching Topology Workbench in Power Electronics Teaching

Original

H-Bridge Converter as Basic Switching Topology Workbench in Power Electronics Teaching / Musumeci, S., Tenconi, A., Bojoi, R., Fratta, A., Armando, E., Mandrile, F.. - In: ENERGIA ELETTRICA. SUPPLEMENTO. - ISSN 1590-7643. - 97:1(2020). [10.36156/ENERGIA06_03]

Availability:

This version is available at: 11583/2979040 since: 2023-06-14T12:58:44Z

Publisher:

AEIT

Published

DOI:10.36156/ENERGIA06_03

Terms of use:

This article is made available under terms and conditions as specified in the corresponding bibliographic description in the repository

Publisher copyright

(Article begins on next page)

H-Bridge Converter as Basic Switching Topology Workbench in Power Electronics Teaching

S. Musumeci, A. Tenconi, R. Bojoi, A. Fratta, E. Armando and F. Mandrile
DENERG Politecnico di Torino, Corso Duca Degli Abruzzi 24, 10129 Torino, Italy

Received: 15 May 2020; Reviewed: 30 May 2020; Published: 8 June 2020

Abstract— This article deals with an effective power electronics learning setup based on a Full-Bridge converter used to teach electrical energy conversion experimentally. In the proposed learning by doing methodology, the hardware and the software are properly mixed in order to obtain an easy-to-use experimental learning environment. In this paper, the H-Bridge is the fundamental brick to build students' knowledge on the main topics of power electronics converter circuit in different operative conditions. This H-Bridge comes with a reconfigurable output LCL to achieve several basic DC-DC power converters topologies. Converter current and voltage switching behavior can be investigated using the proposed setup. Furthermore, the friendly hardware and software set-up allows studying the converter modulation and control techniques of the different power electronics circuits.

Index Terms— H-Bridge, Buck, Boost, Learning by doing, Power Electronics, DC-DC power converter.

I. INTRODUCTION

POWER electronics is an engineering discipline that involves complementary skills ranging from electronic devices, circuit electronics, with mixed digital and analog controls systems, sensors, electrical power systems etc. The multidisciplinary nature of power electronics is graphically summarized in Fig. 1 [1]. Nowadays, power electronics is an enabling technology in the energy transition scenario. Furthermore, power electronics is strictly linked with several fields of technological growth such as consumer electronics, IT and communications, Electrical networks, utilities, Industrial Drives and Robotics, Transportation and Automotive etc. Power electronics is, therefore, a complex learning subject because it has many multidisciplinary topics whereby it requires an adequate learning methodology [2]. Electrical engineers working with power electronics must possess adequate theoretical knowledge together with solid experimental skills. The best strategy applied on complex learning system such as power electronics is to learn through a laboratory approach with simulations and experimental tests [3]. This learning methodology is based on a "learning by doing" approach. Learning objectives are configured in the form of "Know how to do" rather than "know what"; in fact, in this way the student becomes aware of why it is necessary to know something and how a certain knowledge can be used.

According to this learning approach based on the theory of constructivism, knowledge is built on the basis of lived experiences on which it is pondered how they can be understood and applied in different topics [4]. The purpose of this article is to present an effective example of "learning by doing" methodology applied at power electronics used in the energy conversion course of Politecnico di Torino. This learning approach allows the students to overcome the complexity of the theory through the experimental investigation on a Full-Bridge based laboratory set-up. The Full-Bridge topology consisting of four switches, simply called H-Bridge, is taken as the basic topology to study several types of converters [5]. The H-bridge is recognized as the "brick" to make the basic converter topologies used on several static energy conversion applications in DC-DC, DC-AC and AC-DC conditions. In applications such as those in the automotive and industrial field, many modern converters are based on topologies that have H-Bridge circuits built using "switching legs" as their fundamental building block. Considering the H-Bridge circuit as an educational platform the learning methodology allows synthesizing different circuit topologies by means of a suitable layout arrangement as shown below in the paper. Furthermore, the H-Bridge topology combined with micro-controller systems also lends itself to the analysis and learning of modulation techniques and the development of software for the control of the converters.

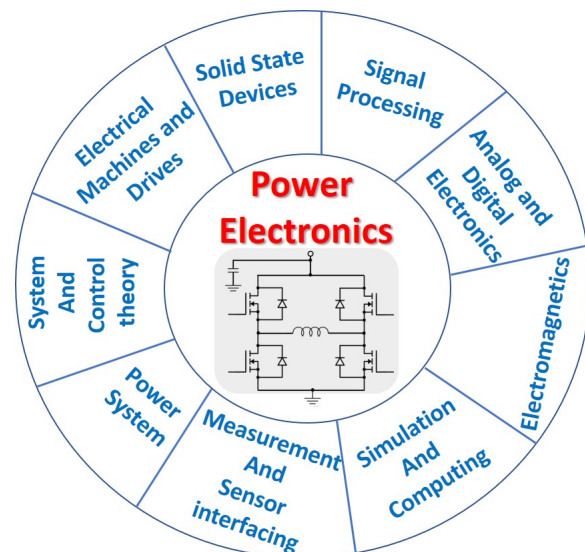

Fig. 1. Main topics linked with power electronics.

In educational literature on power electronics, there are several cases of educational kits oriented to simplify the training course with complex hardware systems arrangement and software simulation tools [6], [7]. In the proposed teaching system, a simple H-Bridge topology accompanied by a microcontroller is able to present the basic principles of power electronics in an effective and extensible hands-on way. This paper starts with an explanation of the H-Bridge and the load arrangement as power electronics experimental measurement set-up to investigate the basic converter topology. Furthermore, the modulation techniques, control methods with relative software are described to know the link between circuit topology and control technique. The learning process of a DC to DC conversion systems module for a power electronics course devoted to an undergraduate degree is focused and described. Moreover, some examples of the experimental investigation on the H-Bridge in DC-DC applications are shown.

II. THE LEARNING PROCESS FLOW-CHART

The learning process described requires several of teaching steps with simulation runs and experimental tests. In this section as example of the learning methodology, the DC-DC converters topics, a learning flow-chart can be described to adjust and standardize the different steps of the teaching procedure. The learning flow-chart shown in Fig. 2 is developed in two parts. In the first part, the basic switching converter topology is studied and experimentally investigated. In the second part, the modulation technique and both the voltage and current control methods are introduced and evaluated with simulation and experimental tests.

In the first part, the flow chart describes the converter's response to the main circuit physical parameters variation

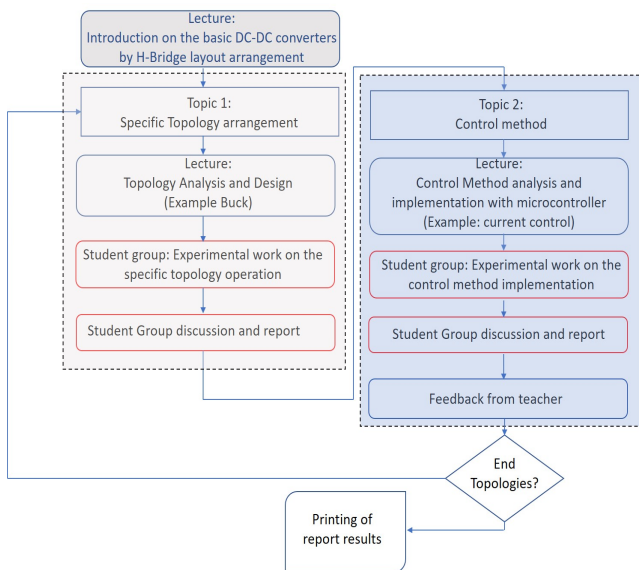

Fig. 2. Flow-chart of the learning procedure in the case of study of DC-DC converters topic.

through simulation tests. After the simulations, the experimental working conditions are verified in the laboratory workbench. The workbench (as better described in the specific

section) is made with the H-Bridge converter controlled by the microcontroller system, desktop PC and measurement set-up with digital scope.

The basic software learning procedure consists of:

- conditioning and filtering of analog signals;
- analog and digital feedback acquisition;
- control algorithm execution;
- modulation.

Both in the development of control techniques and modulations as well as in research and industrial research environments it is practical to simulate the system prior to its physical realization. Today, for example, Hardware in the Loop (HiL) validation systems are very common, based for example on dSPACE or PLECS [8],[9]. In HiL the software and the hardware are combined to create models representative of the final system. A general block diagram for industrial code development is shown in Fig. 3. Generally, the control algorithm for power converters is developed with two different scopes. First, the control algorithm is implemented on a rapid prototyping platform (e.g. Plexim RTbox or dSPACE), using code generation. This design approach is typical in the research and development conditions, since it allows a rapid testing of novel control techniques without spending much time into the hardware development. Later, to actually implement the control algorithm on an industrial product, the code must be developed for a specific industrial microcontroller, often in lower level programming languages, such as C. Although rapid prototyping is optimal in research phase, it is preferable to teach the students how to approach an industrial microcontroller, as it will be useful to them in their future professional life.

The microcontroller code is already given in several parts

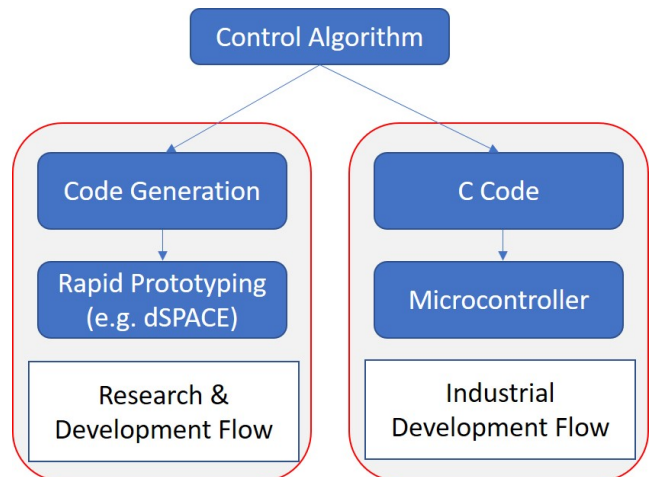

Fig. 3. Flow-chart of the control algorithm design in research and development process and in the case of industrial development flow.

such as the acquisition data block and timers. The students are able to vary some parameters in the code to drive the arranged converter for the evaluation of the operative conditions. Then the code (developed in C language) used in the simulations is implemented in the microcontroller unit. The microcontroller output response allows evaluating the differences and approximations assumed in the simulations. In the laboratory workbench students adjusting the code already partially set to

focus the attention on the use of control system and the variation of the coefficients to tune the regulator block. The learning process is over when a comprehensive report is delivered. The report must demonstrate that the topic addressed was understood in the various theoretical and laboratory parts. Furthermore, technical reporting is an important skill for their professional careers.

III. H-BRIDGE CONVERTER AS BASIC BRICK IN POWER ELECTRONICS APPLICATIONS

The H-bridge circuit may be utilized to analyze the main issues on AC-DC, DC-DC, DC-AC energy conversion. For example, in DC-DC applications the H-Bridge topology is used to produce high density modular power supplies for several field of modern power electronics applications such as battery charge solutions, telecom, lighting and wireless system [10]-[13]. Furthermore, H-Bridges are used in four quadrants DC motor or bipolar stepper motor drive [14], [15]. Moreover, the H-bridge is the fundamental structure to build multilevel high-voltage power converter systems such as the Cascaded Cell Multilevel Converter (CCMC) [16]. In DC-AC Energy conversion the Full-Bridge converter is the basic structure for a single-phase inverter driven by a sinusoidal control voltage [17].

In this learning approach the H-bridge is used as a general-purpose “demonstrator” circuit to explore several topics on power electronics. The H-Bridge circuit in the proposed solution is realized with low-voltage MOSFETs as switches considering the body diode to realize a bidirectional current switch [18], [19]. The schematic of the simple Full-Bridge topology with an inductive load is shown in Fig. 2a. In the case of AC-DC applications, a diode bridge rectifier must be connected to the AC input voltage to create a capacitive DC-Link for the H-Bridge topology [20].

In power electronics applications, this basic circuit topology allows explaining the energy content variation on the load through a changing of the average voltage and current value by means of a suitable control voltages strategy on the switches.

The DC-DC energy conversion case is considered as a learning model to show the effectiveness of the proposed learning by doing approach. In this experimental learning system, the H-Bridge is used to obtain different basic topologies such as the Buck, the Boost and the Buck and Boost converters. For this purpose, the output load of the classic H-bridge

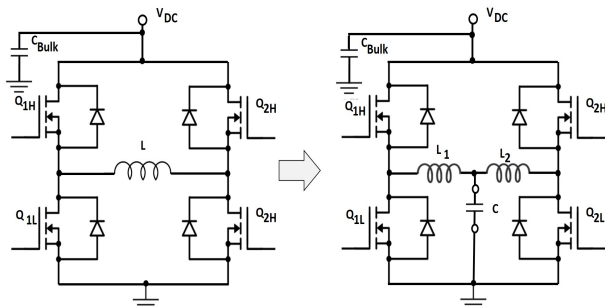

Fig. 4. a) Simplified MOSFET H-Bridge topology, b) load modified H-Bridge Converter.

topology consisting of an inductor, as shown in Fig. 4a, is modified by suitably connecting a circuit network consisting of two inductors and a capacitor (LCL load) as shown in Fig. 4b. In this circuit solution, the load inductance is divided into two parts and a ground-related capacitance is connected to the central point. Starting from the modified load H-bridge using only one leg of the circuit topology or the two legs with suitable arranging of the circuit layout and taking into account of the load LCL is possible to achieve the basic DC-DC converters as shown in Fig 5.

The Buck converter topology can be obtained starting from the

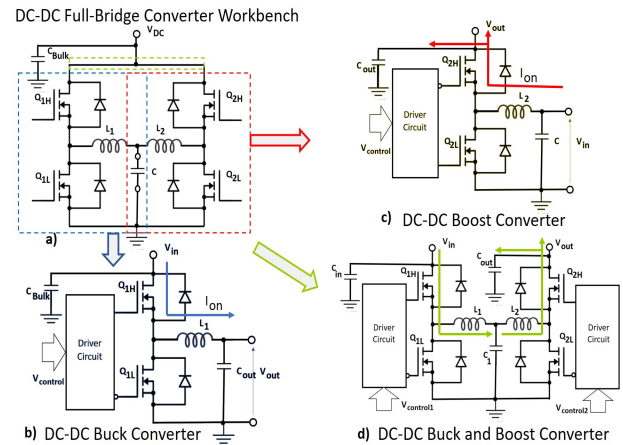

Fig. 5. a) Buck converter topology, b) Boost converter topology, c) Buck and Boost converter topology. The three circuit are achieved through the L H-Bridge and LCL layout arranging.

H-Bridge with LCL load (Fig.5a) considering only a switching leg (Q_{1H} , Q_{1L}) and a single inductance connected to the capacitance as depicted in Fig. 5b. In the step-down converter arrangement, the current (I_{on}) flowing from V_{in} (the voltage V_{DC} of the H-Bridge) to V_{out} (voltage across the capacitor C) at Q_{1H} in on state as shown in Fig. 5b. The Boost converter is achieved considering the switching leg circuit with Q_{2H} and Q_{2L} swapping input and output as shown in Fig. 3c. In the step-up converter circuit diagram (Fig. 5c) the current I_{on} flows from the voltage across the capacitor C (V_{in}) to the output voltage V_{out} (the voltage V_{DC} of the H-Bridge)

Finally, the non-inverting Buck and Boost converter is realized combining the two switching legs. The V_{DC} pin layout is separated in two voltage point V_{in} for the step-down switching leg and V_{out} for the step-up switching leg as shown in Fig. 5d. The Buck and Boost converter open-loop voltage ratio is achieved by the arrangement of the duty-cycle D relationships of the two cascade converters. From Fig 5d

$$\frac{V_{out}}{V_{in}} = \frac{V_C}{V_{in}} \cdot \frac{V_{out}}{V_C} = D \cdot \frac{1}{1-D} \quad (1)$$

In addition to the basic circuits of the DC-DC conversion through the H-Bridge with a suitable layout, it is possible to study more advanced and complex topologies nowadays widely used in the field of power electronics interfaced to the electrical network such as the power factor corrector (PFC) circuits implemented with Boost converter in bridgeless or interleaved

solution [21], [22]. In Fig. 6a an interleaved Boost PFC with two legs is described. The input voltage is supplied in the capacitor C position of LCL load. In this topology, the control gate signal of the two lower devices is shifted to 180° in order to reduce the input current ripple [23]. In the case of the H-Bridge circuit operating as PFC, the upper devices can be used as a synchronous switch to decrease the direct voltage drop reducing the power losses or can be left open, using the parallel body diode [24]. Another possible converter topology achievable by the H-Bridge modified using the Boost arrangement is the Boost inverter shown in Fig. 6b [25]. It is used in renewable energy conversion to charge and discharge a storage battery. The boost inverter topology is composed of two converter stages. Each converter is a current bidirectional boost converter. The modulation technique of each converter is implemented by two 180° degrees out of phase sine functions [26].

As described above, using the modified H-Bridge it is possible to study both the basic circuits of the DC-DC conversion and the specific topologies AC-DC (for example rectifiers with boost PFC) and DC-AC (single-phase inverters or boost inverters). In any case, when implementing a measurement set-up that involves students in experimental tests, it is necessary to maintain restrictive safety criteria. In the

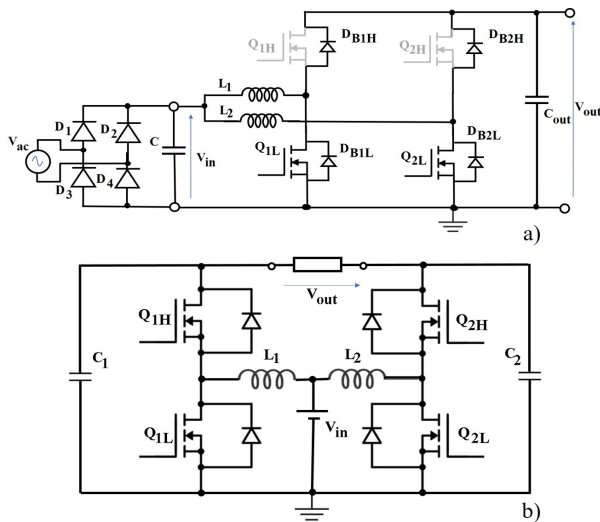

Fig. 6. a) Dual legs interleaved Boost PFC topology. The upper devices (MOSFET, Q_{1H} , Q_{2H} and diode D_{B1H} , D_{B2H}) can be used in alternative way in Boost PFC application. b) Boost inverter converter topology.

experimental realization of the H-Bridge converter, consequently to the limitations given by safe measurement conditions, the maximum voltage is set at 48V. The switching devices was chosen with a suitable breakdown voltage limitation and satisfying dynamic performance. The MOSFETs in the experimental converter arrangement are in trench-gate technology with strip-layouts and features a breakdown voltage of 100V [27]. A crucial topic in learning the operation of the power converters is the correct propagation of the PWM signal from the microcontroller to the gate of the power devices in the bridge leg.

In order to command a power transistor, it is necessary to

apply a proper voltage amplitude and current level to its gate (base). The PWM signal is not suitable to directly command a power transistor used in power electronics systems. The on-state gate voltage (e.g. 15 V) is in fact higher than the standard voltages of the CMOS / TTL logic (3.3 V or 5 V). For this reason, an interface is required between the control logic circuitry and the power switch. Then, the primary function of a driving circuit is that of a power amplifier and level shifter. Furthermore, the devices of the bridge leg must be driven in the opposite way to avoid short circuit.

Moreover, power devices have fixed switching times whereby it is necessary to take them into account. To avoid cross-conduction, dead times must be included in the timing of the driver circuit signals of up-side and low-side transistors.

Another important point to consider is the electrical isolation between power and control. The driving signal of the high side of the bridge devices must be isolated from the gate signal of the low side switch since the electrical reference point of the signals, for the high side switch, is not fixed, but floating. Furthermore, in the driver circuit, insulation is necessary to separate the high voltage power path from the low-voltage signal path [28]. In case of failure, the electrical separation allows isolating the signal part avoiding the propagation of the faults. Insulation also allows a reduction in the propagation of disturbances [29]. Fig. 7 shows the circuitry needed to drive the MOSFETs of the bridge leg (Buck converter arrangement) with

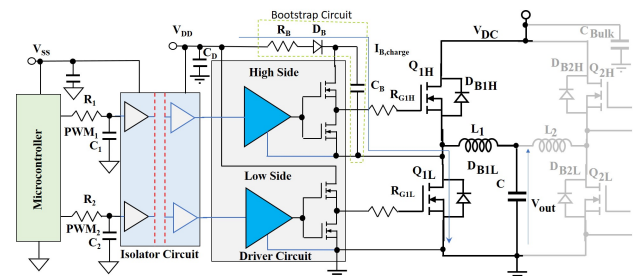

Fig.7. Propagation of PWM signal from the microcontroller circuit to the gate of the MOSFETs in the switching leg.

the PWM signals. The PWM signals after a low pass filter are isolated and after are amplified and level shifted by the driver circuit. The driver circuit of the switching leg MOSFETs is composed of a low-side and high-side circuit. The high side circuit is supplied by a bootstrap circuit referred to the central point of the bridge leg. The capacitance charging current (I_B) path is shown in Fig. 7. The capacitance value may be obtained by

$$C_B \geq \frac{Q_G}{V_{DD} - V_{FB} - R_B \cdot I_B - V_{GG,off}} \quad (2)$$

Where the Q_G is the gate charge of the MOSFET, V_{FB} is the diode direct voltage drop and $V_{GG,off}$ is the minimum voltage allowed across the capacitor C_B during the off-state of high-side MOSFET.

IV. MODULATION TECHNIQUES AND CONTROL METHODS:
TRAINING WITH H-BRIDGE CONVERTER

Modulation techniques and control systems are more easily understood through an application methodology that works through simulations and experimental tests. To show the learning method, in a simple case let's examine the H-Bridge that drives a RL load. To evaluate the evolution of a basic control systems, the output response to a step signal can be considered. The schematic of the H-Bridge considering the control circuit and the driver circuits is reported in Fig. 8a. The output current is controlled by a proportional integral (PI) controller and a pulse width modulation (PWM) is implemented to control the power devices. The output step current response simulation result is reported in Fig. 8b. The simulation allows to understand the first-order evolution of the I_L output current. Simulations runs are carried out with a power electronics system-oriented software tool (*PLECS*[®]). The block scheme of the PI controller and the pulse width modulation (PWM) implemented in the simulation tool is reported in Fig. 9. Simulations are used to make the students understand the different effects of parameters tuning, load variations and parameters mismatch. The result of the activity is a C code that can be later implemented in a microcontroller unit of the experimental setup [30]. This way, the students can use and learn with a widespread simulation tool and quickly try different control parameters. The output of this first learning phase is a short report showing the main significative results and the control procedure method, showing similar results to

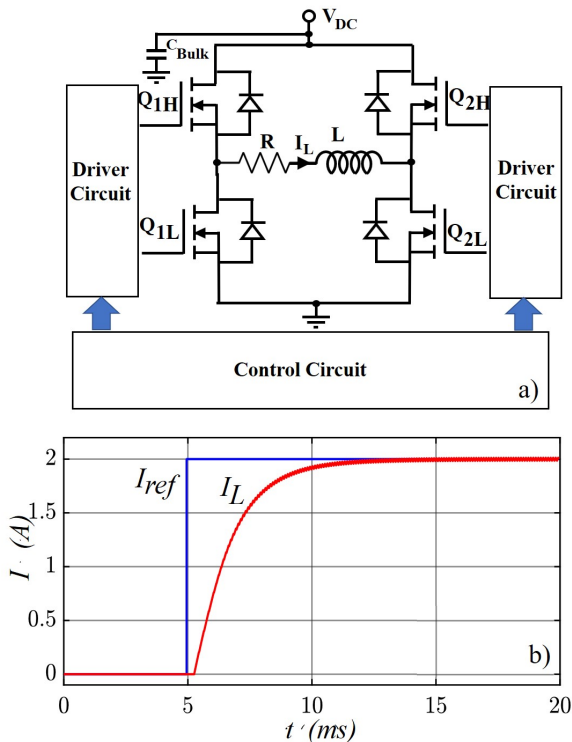

Fig. 8. a) H-Bridge and control circuit with RL load. b) Simulation results of the inductive output current at reference current step response.

Fig. 8b. Afterwards, to complete the learning method, the experimental tests are carried out, using the actual H-Bridge power stage with an RL load as it will be shown in the proper section.

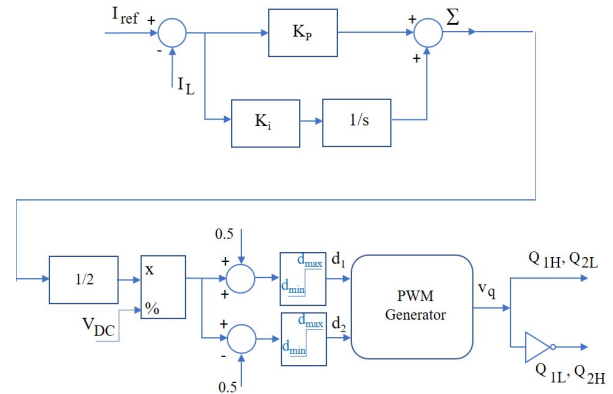

Fig. 9. Block diagram of PI control scheme and PWM generator.

A. Case of Study with Modified H-Bridge

The modified H-Bridge described in Fig. 4b can be used to investigate the converter operation and the output current and voltage responses with the basic control methodology obtained by means a PWM modulation technique. In the proposed case of study, a suitably mixed voltage and current control are evaluated allowing the modulation of the capacitor charge through the two switching legs of the H-Bridge. The first leg (Q_{1H} and Q_{1L}) is led by a current control to provide the requested charging current to capacitor C, while the voltage control is applied to the second leg (Q_{2H} , Q_{2L}) to modulate the capacitance-voltage. The voltage control is obtained by an open-loop duty-cycle control. The described mixed control method can also have an actual application. The modified H-Bridge circuit considered can be used as a battery charger replacing the capacitor with a battery. In this case, the converter circuit allows controlling the current charge profile at different supplied voltage. As the first step, the converter operation and the voltage and current control transient behavior are evaluated by a simulation tool as in the simple current control with RL load. In laboratory simulation activities the students are organized in groups of 4 to evaluate in teams how mixed control and PWM modulation technique affect the performance of the converter in terms of both current and output voltage. Each group of students can simulate the control system and generate the C code that will be implemented on the microcontroller in the later experimental activity. The different control systems block diagram of both output current I_{L1} , I_{L2} and voltage $V_{out}=V_C$ is reported in Fig. 10. For the second leg (Q_{2H} , Q_{2L}), the voltage control may be chosen in closed-loop or in open-loop mode to investigate the different output voltage behavior. In the Buck converter application of Fig. 5b in the current control diagram, the Σ value is divided by V_{in} . In the case of a leg used as Boost converter (Fig. 5c), Σ is divided by V_{out} to correct output current control. In the simulation tests, the input voltage V_{DC} is fixed at 48V. The output voltage V_C is selected

at 24V. The control procedure is implemented in C language. The simulation results for the output current and voltage transient behavior are shown in Fig. 11. Simulation tests show the effects of the different control methods on the capacitor voltage and inductor current. The output electrical quantities simulation starts acting the voltage control on the capacitor voltage performed by the use of the second leg (Q_{2H} , Q_{2L}). A ramp reference is supplied until the voltage V_C up to 24V. At a selected voltage of 24V, the output voltage control is stopped and after a fixed time delay the output current control is activated. In the proposed example, a current reference level of 5A is settled, maintaining the 24V voltage constant duty-cycle control in feed-forward mode. The different voltage control acting in two steps is interesting to evaluate because demonstrate the differences between feedforward and closed-loop voltage ripple effects. The capacitor voltage (V_C) transient behavior is depicted in Fig. 11a. The voltage ripple increases when the voltage control switches from closed-loop to open-loop mode. When the reference current step changes, a momentary loss of output voltage control appears, and as a consequence a voltage peak arises. It is due to the fast-current variation in the circuit inductance. Fig. 11b shows the detail of the initial ramping up of the capacitor voltage V_C . In Fig. 11b the output voltage V_C is controlled by a Proportional Integrative regulator (PI). The PI regulator effect allows the satisfactory following of the reference voltage (V_{ref}) ramp input voltage. Fig. 11c shows the action of the output current control I_{L1} when the current step is imposed. The current control is applied to the H-Bridge first leg (Q_{1H} , Q_{1L}) after an arbitrarily set delay time. Fig. 11d reports the current transient behavior flowing in the inductor L_2 . It is opposite to that in L_1 . In L_2 a low current value can be observable from the initial instant of time. It is due to the capacitor charging phase by the voltage control of the second leg of the H-Bridge (Q_{2H} , Q_{2L}). The example shows that the independent control of the switching legs of the H-Bridge is a flexible way to study and validate the action of the current and voltage controls and their interaction during the converter operation. Furthermore, this example demonstrates the effectiveness of an H-Bridge as a workbench to test different types of control and operating conditions typical of power conversion. Moreover, the H-Bridge allows the evaluation of PWM modulation techniques both in a unipolar and in a bipolar mode due to the possibility of independently switching the single legs as shown in this converter control example.

V. H-BRIDGE CONVERTER AS EXPERIMENTAL WORKBENCH

In the experimental learning system, there are two types of H-Bridge converters. The first case concerns the converter on the teacher's desk. The second converter is related to the student H-Bridge arrangement.

A. Teacher's Desk H-Bridge Workbench Arrangement

The teacher's desk H-Bridge works at $V_{in} = 48V$ and $I_{out}=I_L$ is up to 40A, the switching frequency is set to $f_{sw} = 15kHz$. It is used to perform the lecture concept in an experimental way by means of a flexible converter layout with measurement test points. The control methods and the modulation techniques can be implemented on the teacher's desk in two different modes: with an applied software (*dSPACE*) system and with a

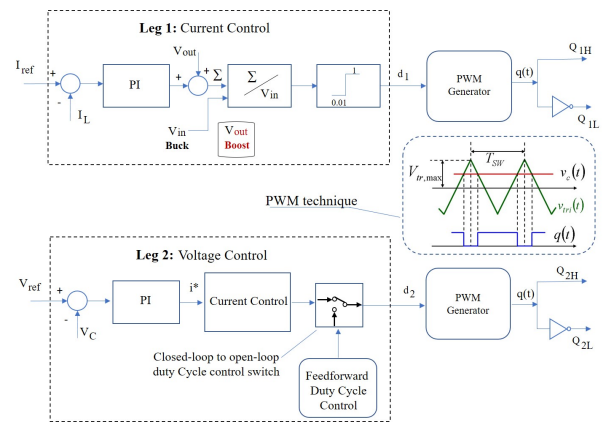

Fig. 10. Block diagram of current control for the leg1 and voltage control in the leg 2. The voltage control can be selected in open-loop mode and in closed-loop mode. The PWM technique principle is also depicted.

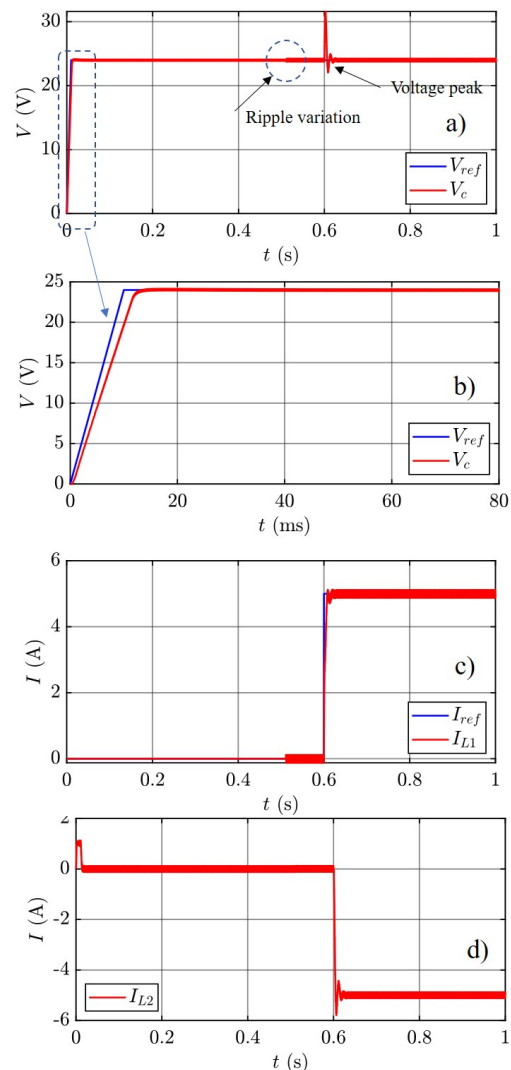

Fig. 11. Simulation results of current and voltage control effect on H-Bridge legs. a) Output voltage ripple variation in feedforward and closed-loop conditions, b) zoomed view of the voltage V_C , c) current control effect on I_{L1} , d) current control effect on I_{L2} .

microcontroller unit (*STM Nucleo board*); for flexibility didactic reasons. The experimental layout system arrangement

of the teacher desk set-up with modified LCL load H-Bridge is reported in the picture of Fig. 12a. In Fig. 12b the photo of experimental set-up arrangement is shown. For demonstration purposes, the circuit of Fig.5d is taken as an example. The power hardware accepts inputs coming either from a microcontroller or from a rapid prototyping environment, such as dSPACE. The analog measurements (current and DC voltages) can be sampled by either platform. The dSPACE platform for the teacher’s bench has been chosen due to its simple graphical user interface capabilities. Thanks to this, the teacher can show the control panel of the converter, plot the converter waveforms and change the control parameters online in a more intuitive way, compared to a microcontroller.

The use of desk experimental set-up allows explaining by a projection of the experimental test to discuss the lecture concept in an interactive way. Furthermore, the H-Bridge converter switching cell is suitable for the analysis of the MOSFETs device transient waveforms to show the discrepancy between an ideal switch and an actual electronic device. The lower MOSFET devices are used in the switches characterization to avoid measurement due to floating ground problem [31]. Moreover, the H-Bridge converter with only inductor load L (Fig. 2a) can be used to evaluate inductance value. In this case, the H-Bridge supplies a voltage square wave to load inductor at different load current. The voltage waveforms across the inductor are obtained by means of the control system that generates a suitable series of square wave pulses with programmable pulse width. With n measurement steps at several pulse width, the L value is given by

$$L = \frac{1}{n} \sum_{i=1}^n \frac{\Delta I_{Li}}{\Delta t_i} V_L \quad (3)$$

Where ΔI_L is the inductive linear current variation, Δt is the pulse width duration and V_L is the voltage across the inductor L . This experimental approach introduces to the study of the magnetic hysteresis, saturation of magnetic cores and magnetic losses.

B. Example of the H-Bridge Modified with LCL Load in Mixed Voltage and Current Control Mode

Example of PWM modulation techniques and control methods can be evaluated experimentally using H-Bridge modified topology with LCL load. In the case of study proposed a PI closed-loop current control acting on the first leg of the H-Bridge (Q_{1H} , Q_{1L}) in the L_1 inductor. The second leg (Q_{2H} , Q_{2L}) is controlled in open-loop duty-cycle voltage control. The capacitor C voltage level is set to 24V. The experimental waveforms of the capacitor voltage and current in L_1 and L_2 are reported in Fig. 13. The current I_{L2} in L_2 is opposite to the current flowing I_{L1} in L_1 . The current waveforms inspection allows evaluating the current ripple behavior. In Fig. 13 is shown the effect of the current control on the experimental waveforms. The current in the inductances of the load LCL following the reference current ramp, keeping the output voltage V_C constant. Furthermore, the H-Bridge workbench allows the evaluation of the voltage switching waveforms across the bridge structure lower devices, as previously

discussed. The experimental switching waveforms in the first leg on the lower Q_{1L} device with the I_{L1} current are reported in Fig. 14. The experimental waveforms focus on the gate voltage $V_{GS,(Q1L)}$, the Drain-Source voltage $V_{DS,(Q1L)}$ and the current I_{L1} . The device switching waveforms are the starting point to explain some issues on the dynamic behavior of a MOSFET device. The current I_{L1} shows a triangular shape and can be used to calculate the L_1 inductance value by (2) with $n=1$.

C. H-Bridge Set-Up Arrangement for Student Workbench

The experimental workbench is an important point of the learning procedure. The experimental workbench is implemented on the H-bridge topology with a suitable microcontroller unit. The converter topology is achieved arranging three-phase inverter expansion board, *X-Nucleo-IHM08M* based on *STripFET™ F7* Power MOSFET [32]. In

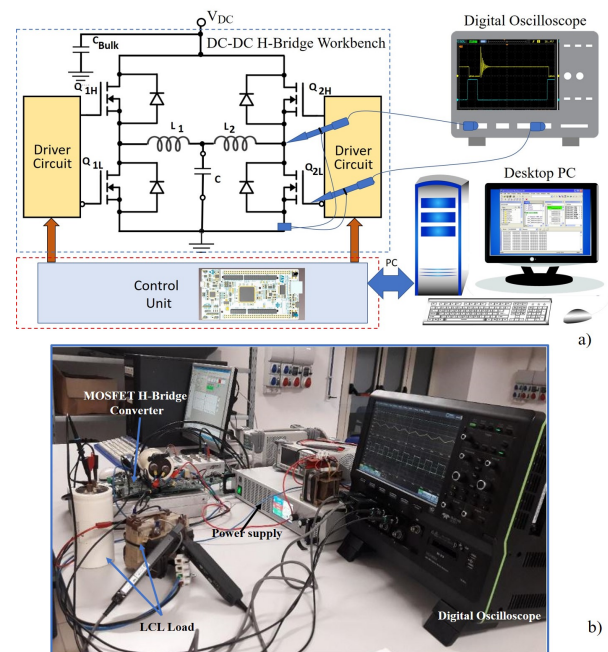

Fig. 12. a) block scheme of experimental hardware and software set-up of the teacher desk H-Bridge with LCL load workbench. b) Photo of actual experimental set-up.

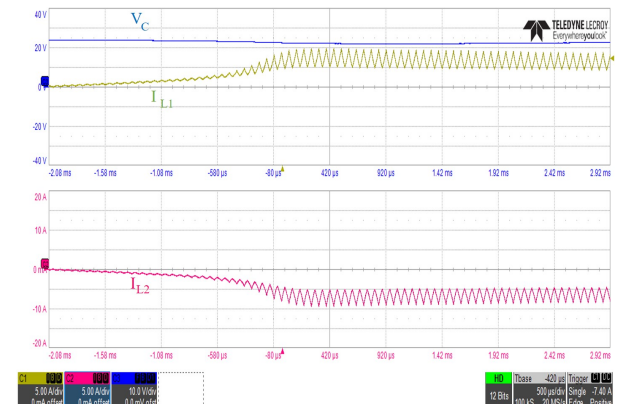

Fig. 13. Experimental current step in H-Bridge with independent control mode on the two legs. $V_C=10V/div$, $I_{L1}=5A/div$, $I_{L2}=5V/div$, $t=500\mu s/div$.

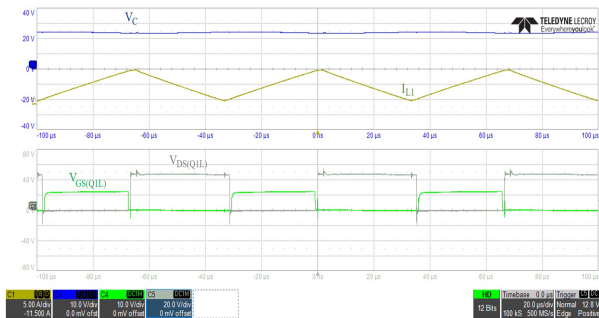

Fig. 14. Experimental waveforms of gate voltage $V_{GS(Q1L)}$ and Drain-Source Voltage, $V_{DS(Q1L)}$ with the output voltage V_c and the inductance current I_{L1} .

$V_c = V_{GS(Q1L)} = 10V/div, V_{GS(Q1L)} = 20V/div, I_{L1} = 5A/div, t = 20\mu s/div.$

the Inverter board, a switching leg is not used to obtain the H-Bridge topology as shown in Fig. 15, where the student workbench is depicted. The control of the three-phase inverter allows the students to familiarize with the electronic board usable in the lectures that will concern the inverters topology and applications [33].

The converter characteristics useful for H-Bridge applications are:

- Nominal operating voltage range: $V_{DC} = 8\text{ V} - 48\text{ V}$
- Maximum output peak current: $I_{out} = 30\text{ A}$
- Nominal RMS output current: $I_{out,rms} = 15\text{ A}$
- 3-Shunt (one each leg) and 1-Shunt configurable jumpers for load current sensing.

The load is arranged through a selectable RLC box to obtain the LCL load (Fig. 15). The microcontroller unit is an *STM32F303K8* (*STMicroelectronics*). A desktop PC is used to code the control in the integrated development environment (IDE) for the microcontroller device. The IDE allows the programming of the microcontroller by universal serial bus (USB).

Even though many rapid prototyping platforms are available on the market (e.g. dSPACE, Imperix or RTbox), it is more effective to make students work with an industrial microcontroller. In fact, most students will have to work with them in their professional life, without any access to higher level rapid prototyping environments.

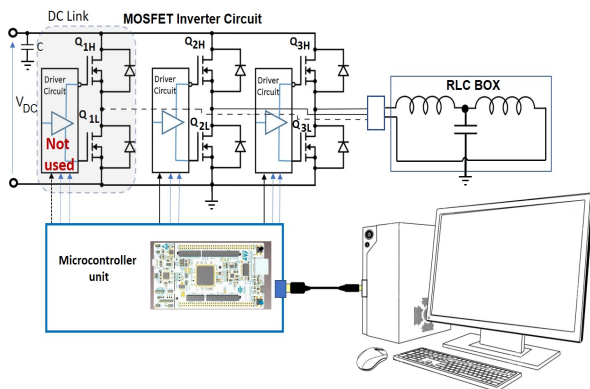

Fig. 15. Experimental student set-up with the MOSFET inverter circuit. In the H-Bridge arrangement a switching leg is not used. The LCL load is realized with RLC BOX.

Power supplies and a digital oscilloscope with current and voltage probes are the measurement set-up of the selected experimental workbench. In Fig. 16 is reported the picture of the laboratory set-up in the case of study with an H-Bridge topology with current control of an RL load (Fig. 5). The step current control response is observable in Fig. 16. Furthermore in Fig. 16, the *X-Nucleo-IHM08M* and the *STM32F303K8* microcontroller unit is focused. The experimental activities are carried out in a specialized "Tommasini" laboratory [34]. In the laboratory, there are 8 workbenches, capable of hosting up to 40 students at the same time. Each workbench is equipped with

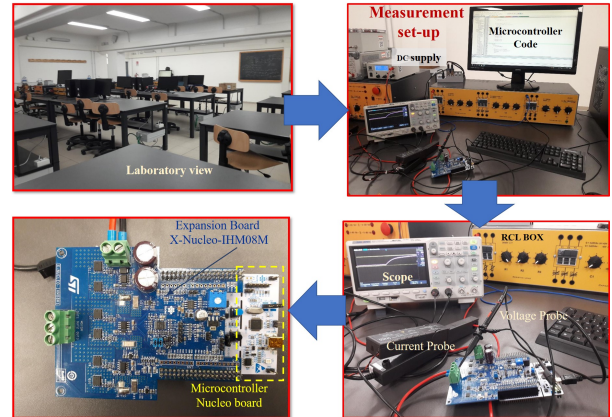

Fig. 16. Photo of the laboratory view and experimental student set-up with the MOSFET inverter circuit, microcontroller unit and RLC box to arrange the requested load. The scope picture is related to the RL current response at step current reference.

an electric motor test rig and several measurement facilities such as DAQ devices interfaced by *LabVIEW* with PC, AC and DC power supplies, electronics load and a digital multimeter. In the laboratory is possible performing various experimental activities of power electronics, electric drives and micro-grids control. The photo of a global view of the "Tommasini" laboratory is reported in Fig. 16.

VI. CONCLUSION

In the article, a "learning by doing" approach based on the use of the H-Bridge topology was described. The H-Bridge circuit was used as the basic circuit to explain the fundamental contents of the first-level course on power electronics. As an example of the learning procedure, a basic DC-DC converters structure were focused. The H-Bridge legs are arranged as switching poles to obtain several basic DC-DC converter topologies through a suitable layout of a passive output LCL network. Furthermore, the modulation techniques and control methods operation were evaluated by the H-Bridge workbench. In this paper, the current and voltage control strategies can be applied in a mixed-mode in the two bridge legs to analyze and compare the output electrical quantities performance and both current and voltage ripple. This mixed-mode control is implemented by means of the independent control of the output voltage of one leg to reach the fixed reference voltage, while the second leg current control adjusting the requested output current value. The modified H-Bridge was applied to explore

the main topics of the DC-DC structure and control methods by simulation runs and experimental tests. The experimental set-up for the teacher desk and student workbenches in the laboratory environment is described and discussed to obtain a hands-on experience for the student. Moreover, a flow-chart of the learning procedure is presented. The presented "learning by doing" process allows to obtain the fundamental skills of the complex subject of power electronics using a laboratory-based methodology.

ACKNOWLEDGMENT

The authors would like to thank Dr Fausto Stella for his valuable work in setting up the workbench in the experimental learning phase for students.

A. References

- [1] N. Mohan, "Power Electronics: A First Course," New York, USA, John Wiley and Sons, Inc, 2011.
- [2] P. Bauer and J. W. Kolar, "Teaching power electronics in the 21st century" in *EPE Journal*, vol. 13, no.4, November 2003, pp.43-50.
- [3] F. J. Maseda, I. Martija and I. Martija, "An active learning methodology in power electronic education," in *2014 IEEE Frontiers in Education Conference (FIE) Proceedings*, Madrid, October 22-25, 2014, pp. 1-5.
- [4] P.C. Blumenfeld, et al., "Motivating projectbased-learning: sustaining the doing, supporting the learning," in *Educational Psychologist*, vol. 26, no.3-4, 1991.
- [5] E. Armando, R. Bojoi, A. Fratta, F. Mandrile, S. Musumeci and A. Tenconi, "H-Bridge Converter as Power Electronics Workbench: An Effective Teaching Case of Learning by Doing," *2019 21st European Conference on Power Electronics and Applications (EPE '19 ECCE Europe)*, Genova, Italy, 2-6, September 2019, pp. P.1-P.10.
- [6] Osama S. Saadeh, Moh'd Rashad D. Al-Mothafar "Power Electronics Laboratory Education: the JUST Experience," *Conf. Rec. 2017 IEEE First Ukraine Conference on Electrical and Computer Engineering (UKRCON)*, Kyiv (Ukraine) 29 May-2 June 2017, pp. 1191-1196.
- [7] K. Jitngamkam, M. Phattanasak, R. Gavagsaz-Ghoachani, P. Sethakul, "Power-Electronics Learning through experiment and simulation: DC-DC converters," *Conf. Rec. 2016 IEEE International Conference on Teaching, Assessment, and Learning for Engineering (TALE)*, Bangkok, Thailand, 7-9 December 2016, pp. 403-408.
- [8] Y. V. P. Kumar and R. Bhimasingu, "Alternative hardware-in-the-loop (HIL) setups for real-time simulation and testing of microgrids," *2016 IEEE 1st International Conference on Power Electronics, Intelligent Control and Energy Systems (ICPEICES)*, Delhi, 4-6 July 2016, pp. 1-6.
- [9] M. Ciobotaru, T. Kerekes, R. Teodorescu and A. Bouscayrol, "PV inverter simulation using MATLAB/Simulink graphical environment and PLECS blockset," *IECON 2006 - 32nd Annual Conference on IEEE Industrial Electronics*, Paris, 6-10 Nov. 2006, pp. 5313-5318.
- [10] I. Lee and J. Kim, "A high-power DC-DC converter for electric vehicle battery charger," in *2017 IEEE 3rd International Future Energy Electronics Conference and ECCE Asia (IFEEC 2017 - ECCE Asia)*, Kaohsiung, June 3-7, 2017, pp. 1861-1866.
- [11] S. Musumeci, F. Fusillo, F. Scrimizzi, R. Bojoi, A. Raciti, S. Rizzo, "Full-Bridge DC-DC Power Converter for Telecom applications with Advanced Trench Gate MOSFETs," *Conf. Rec. IEEE - INTELEC 2018 - International Telecommunications Energy Conference*, Torino, Italy, 7-11 October 2018, pp 1-7.
- [12] L. E. Amraoui and G. Zissis, "Design and optimization of a DC-DC converter for LEDs lighting applications," in *2019 IEEE 13th International Conference on Power Electronics and Drive Systems (PEDS)*, Toulouse, France, 9 – 12 July 2019, pp. 1-6.
- [13] R. Ruffo, M. Khalilian, V. Cirimele, P. Guglielmi, M. Cesano, "Theoretical and experimental comparison of two interoperable dynamic wireless power transfer systems for electric vehicles," in *2017 IEEE Southern Power Electronics Conference, (SPEC)*, 4-7 December 2017, Puerto Varas, Chile, pp. 1-6.
- [14] K. Mehta, P. Jain, A. Mecwan, D. Kothari and M. Chauhan, "Design implementation of high performance DC motor drive," in *2014 International Conference on Advances in Computing, Communications and Informatics (ICACCI)*, New Delhi, September 24-27, 2014, pp. 740-745.
- [15] M. Y. Tarnini, "Fast and cheap stepper motor drive," in *2015 International Conference on Renewable Energy Research and Applications (ICRERA)*, Palermo, November 22-25, 2015, pp. 689-693.
- [16] Zhang Y., Li X., Miu Z., Kundanam K., Liu J., Liu Y., "High step-up full bridge DC-DC converter with multi-cell diode-capacitor network," *Conf. Rec. 2017 IEEE Applied Power Electronics Conference and Exposition (APEC)*; Tampa, Florida USA, March 26-30, 2017, pp. 26–30.
- [17] J. Xu and K. Han, "The Single-Phase Inverter Design for Photovoltaic System," in *2016 International Symposium on Computer, Consumer and Control (IS3C)*, Xi'an, July 4-6, 2016, pp. 341-344.
- [18] A. Raciti, F. Chimento, S. Musumeci, F. Xibilia, G. Privitera "A Bi-Dimensional Model for Power MOSFET Devices Accounting for the Behavior in Unclamped Inductive Switching Conditions," *Conf. Rec. IEEE IECON 2013*, Vienna, Austria, November 10-13, 2013, pp. 134-139.
- [19] K. Askan, M. Bartonek and F. Stueckler, "Bidirectional Switch Based on Silicon High Voltage Superjunction MOSFETs and TVS Diode Used in Low Voltage DC SSCB," in *PCIM Europe 2019; International Exhibition and Conference for Power Electronics, Intelligent Motion, Renewable Energy and Energy Management*, Nuremberg, Germany, May 7-9, 2019, pp. 1-8.
- [20] H. Wang, H. Wang, G. Zhu and F. Blaabjerg, "An Overview of Capacitive DC-Links-Topology Derivation and Scalability Analysis," in *IEEE Transactions on Power Electronics*, vol. 35, no. 2, pp. 1805-1829, Feb. 2020.
- [21] G. Anand and S. S. K. Singh, "Design of single stage integrated bridgeless-boost PFC converter," in *2014 International Conference on Medical Imaging, m-Health and Emerging Communication Systems (MedCom)*, Greater Noida, India, November 7-8, 2014, pp. 458-463.
- [22] S. Musumeci, R. Bojoi, E. Armando, S. Borlo, F. Mandrile, "Three-Legs Interleaved Boost Power Factor Corrector for High-Power LED Lighting Application," in *Energies* 2020, 13, 1728.
- [23] S. Borlo, et al., "Comparative CCM-DCM Design Evaluation of Power Inductors in Interleaved PFC Stage for Electric Vehicle Battery Chargers," in *2019 International Conference on Clean Electrical Power (ICCEP)*, Otranto, Italy, July 2-4, 2019, pp. 180-186.
- [24] S. Di Mauro, et al., "Synchronous rectification with low voltage MOSFETs in LLC converters," in *AEIT International Annual Conference (AEIT)*, 2017, Cagliari, Italy, September 20-22, 2017, pp. 1-6.
- [25] Ramon O. Caceres, and Ivo Barbi, "A Boost DC-AC Converter: Analysis, Design, and Experimentation" in *IEEE Transactions on Power Electronics*, Vol. 14, No. 1, January 1999, pp. 134-141.
- [26] Rafia Akhter, Aminul Hoque "Analysis of a PWM Boost Inverter for Solar Home Application," in *World Academy of Science, Engineering and Technology International Journal of Electrical and Computer Engineering* Vol:2, No:11, 2008, pp. 2626- 2630.
- [27] E. Armando, F. Fusillo, S. Musumeci and F. Scrimizzi, "Low Voltage Trench-Gate MOSFETs for High Efficiency Auxiliary Power Supply Applications," in *2019 International*

- Conference on Clean Electrical Power (ICCEP)*, Otranto, Italy, July 2-4, 2019, pp. 165-170.
- [28] R. Pagano, S. Abedinpour, A. Raciti and S. Musumeci, "Efficiency modeling of wireless power transfer ASICs accounting for layout parasitics," 2016 IEEE Energy Conversion Congress and Exposition (ECCE), Milwaukee, WI, 18-22 Sept. 2016, pp. 1-8.S.
- [29] Musumeci, A. Fratta, E. Armando, F. Mandrile and S. Borlo, "Soft Switching Full-Bridge Isolated Circuit Solution for Auxiliary Power Supply in Power Converter Systems," IECON 2019 - 45th Annual Conference of the IEEE Industrial Electronics Society, Lisbon, Portugal, 14-17 Oct. 2019, pp. 1985-1990
- [30] S. Krithiga and N. A. Gounden, "A microcontroller based power electronic controller for PV assisted DC motor control," in *2011 6th International Conference on Industrial and Information Systems*, Kandy, Sri Lanka, August 16-19, 2011, pp. 505-510.
- [31] J. Chen et al., "A Comprehensive Analysis of Voltage to Ground of Floating Submodule for MMC," in *2019 21st European Conference on Power Electronics and Applications (EPE '19 ECCE Europe)*, Genova, Italy, 2-6, September 2019, pp. P.1-P.9.
- [32] E. Armando, S. Musumeci, F. Fusillo and F. Scrimizzi, "Low Voltage Trench-Gate MOSFET Power Losses Optimization in Synchronous Buck Converter Applications," *2019 21st European Conference on Power Electronics and Applications (EPE '19 ECCE Europe)*, Genova, Italy, 2-6, September 2019, pp. P.1-P.10.
- [33] G. J. van der Merwe and L. van der Merwe, "Inverters-the investigation to the optimal topology to the designing of a sinewave inverter range for the use in static as well as mobile applications," in *IEEE International Symposium on Industrial Electronics. Proceedings. ISIE'98 (Cat. No.98TH8357)*, Pretoria, South Africa, July 7-10, 1998, pp. 51-56 vol.1.
- [34] A. Cavagnino, G. Pellegrino, A. Estebarsari, E. Armando, R. Bojoi "A New Laboratory for Hands-on Teaching of Electrical Engineering," *2018 IEEE 27th International Symposium on Industrial Electronics (ISIE)*, Cairns, Australia, 13-15 June 2018, pp. 883-889.