

Battery Pack and Underbody: Integration in the Structure Design for Battery Electric Vehicles—Challenges and Solutions

Original

Battery Pack and Underbody: Integration in the Structure Design for Battery Electric Vehicles—Challenges and Solutions / Belingardi, Giovanni; Scattina, Alessandro. - In: VEHICLES. - ISSN 2624-8921. - ELETTRONICO. - 5:(2023), pp. 498-514. [10.3390/vehicles5020028]

Availability:

This version is available at: 11583/2978128 since: 2023-04-24T07:31:33Z

Publisher:

MDPI

Published

DOI:10.3390/vehicles5020028

Terms of use:

This article is made available under terms and conditions as specified in the corresponding bibliographic description in the repository

Publisher copyright

(Article begins on next page)

Article

Battery Pack and Underbody: Integration in the Structure Design for Battery Electric Vehicles—Challenges and Solutions

Giovanni Belingardi ^{1,2,*}  and Alessandro Scattina ^{1,2} ¹ DIMEAS Department of Mechanical and Aerospace Engineering, Politecnico di Torino, 10129 Turin, Italy² CARS—Center for Automotive Research and Sustainable Mobility, Politecnico di Torino, 10129 Turin, Italy

* Correspondence: giovanni.belingardi@formerfaculty.polito.it

Abstract: The evolution toward electric vehicle nowadays appears to be the main stream in the automotive and transportation industry. In this paper, our attention is focused on the architectural modifications that should be introduced into the car body to give a proper location to the battery pack. The required battery pack is a big, heavy, and expensive component to be located, managed, climatized, maintained, and protected. This paper develops some engineering analyses and shows sketches of some possible solutions that could be adopted. The possible consequences on the position of the vehicle center of gravity, which in turn could affect the vehicle drivability, lead to locate the battery housing below the passenger compartment floor. This solution is also one of the most interesting from the point of view of the battery pack protection in case of a lateral impact and for easy serviceability and maintenance. The integration of the battery pack's housing structure and the vehicle floor leads to a sort of sandwich structure that could have beneficial effects on the body's stiffness (both torsional and bending). This paper also proposes some considerations that are related to the impact protection of the battery pack, with particular reference to the side impacts against a fixed obstacle, such as a pole, which are demonstrated to be the most critical. By means of some FE simulation results, the relevance of the interplay among the different parts of the vehicle side structure and battery case structure is pointed out.

Keywords: electric vehicles; battery pack housing; skateboard architecture; pole lateral impact; rocker reinforcement; FE simulation



Citation: Belingardi, G.; Scattina, A. Battery Pack and Underbody: Integration in the Structure Design for Battery Electric Vehicles—Challenges and Solutions. *Vehicles* **2023**, *5*, 498–514. <https://doi.org/10.3390/vehicles5020028>

Academic Editor: Teresa Donateo

Received: 6 March 2023

Revised: 12 April 2023

Accepted: 18 April 2023

Published: 23 April 2023



Copyright: © 2023 by the authors. Licensee MDPI, Basel, Switzerland. This article is an open access article distributed under the terms and conditions of the Creative Commons Attribution (CC BY) license (<https://creativecommons.org/licenses/by/4.0/>).

1. Introduction

After a lot of debate and international meetings, the evidence of climate change effects has finally pushed governments all over the world to act in order to reduce the emissions of Greenhouse Gases (GHGs). The transportation sector is one of the dominant sources of these type of emissions. Therefore, over the next twenty years, the transportation sector is expected to face a deep transformation in order to meet the required emissions targets, and the mobility industry is asked to provide innovative solutions to reach these objectives. CO₂ emission limits are enforced by the regulation adopted in different countries and they are expected to decrease carbon-based fuel consumption.

In 2018, the transport sector, as a whole, accounted for 21% of the GHG emissions, with road transport alone accounting for 15% [1]. Passenger and goods transports account each for about half of the GHGs emitted by vehicles [1]. The more stringent emission regulations and the possible advantages that can come from innovative vehicles have pushed the manufacturers (OEMs) to start the transition toward alternative propulsion systems.

At present, the most diffused solution is electrification, which includes hybrid electric vehicles (HEVs), plug-in hybrid electric vehicles (PHEVs), and fully electric battery electric vehicles (BEVs). Hydrogen-powered fuel cell electric vehicles (FCEVs) are also considered as a possible evolution, although hydrogen production and refueling distribution are still considered challenging problems [2–4]. In terms of the future, hybrid electric vehicles are

considered a transition toward BEVs, and they are expected to become the prevalent vehicle type in the market [5].

The benefits of the electric powertrain obviously come from the possible diversification of the energy sources, but also from the mechanical characteristics of the electric motor, which make it particularly suitable for vehicle traction. BEVs are accredited for an overall efficiency of up to 35% against an efficiency of 25% for gasoline ICEVs [2,6], and, consequently, in emission reductions ranging from 40% to 60% in real driving conditions [7,8]. In order to perform a complete comparison among the solutions, it is important to also take into account the effective energy density of the on-board energy storage devices. Yu and coworkers presented some data in their recently published paper [9], whereby the effective energy density for the ICE vehicle was largely greater than that of the hydrogen fuel cell vehicles and of the BEVs.

Further, to gather the complete picture, it is necessary to look at the total life cycle emissions of the vehicle, accounting for the emissions from manufacturing, including the vehicle use and end-of-life. A Preformed Life Cycle Analysis (LCA) says that the GHG emissions during battery manufacturing heavily affect the overall life cycle emissions of BEVs. Despite that, the overall life cycle emissions of BEVs are still considered to be at least 17% lower than that for ICEVs [7,8]. Battery recycling will play a crucial role in reducing end-of-life emissions as well as mineral extractions and manufacturing emissions. Battery recycling will allow us to reduce both the cost of the battery and the whole vehicle itself, while coping with a critical base element supply (Lithium and Cobalt) [3,10]. In addition, a “battery second life” is another possible approach that can reduce the end-of-life impacts of BEVs [11]. At present, it is generally accepted that when the battery loses more than 20% of its energy storage capacity due to progressive ageing, it is no longer considered suitable for automotive applications and it has to be replaced. However, (and this is the meaning of “second life”) it still has a sufficient energy performance so that it can be used in less demanding applications, such as stationary energy storage services [12,13].

The main concerns regarding BEVs are currently associated with the battery pack, which is their energy storage medium. In recent decades, Li-ion batteries have become the preferred choice for BEVs thanks to their relatively high energy density and good durability [3,5,10,12]. In [13], a comprehensive comparison of the different Li-ion technologies for battery solutions is reported. In [14], the application of the Life Cycle Assessment (LCA) methodology to battery packs is presented and discussed as, in the perspective of environmental improvement, the transition to BEVs should not induce negative effects caused by the battery packs.

As the energy density of the battery pack is not comparable with one of the fuels, a relevant weight increase, a severe limitation in the driving range, and rather lengthy recharging operations are, at present, affecting BEVs. A trade-off is needed for the effective diffusion and usefulness of these vehicles [5].

In this paper, our attention is focused on the architectural modifications that should be introduced into the car body to give a proper location to the battery pack. The required battery pack is no longer a simple, relatively cheap brick that will be located in the engine compartment, but it is a big, heavy, and expensive component to be located, managed, climatized, maintained, and protected. This paper intends to develop some engineering analyses and reviews by means of sketching out the possible solutions that have already been adopted for market vehicles. The location of the battery pack on board of the vehicle may affect the position of the vehicle center of gravity, which in turn could affect the vehicle’s drivability. In order to lower the possible negative consequences, the battery housing is generally located below the passengers compartment floor. This solution is also one of the most interesting in terms of battery pack protection in case of a lateral impact and for easy serviceability and maintenance. The integration of the battery pack’s housing structure and the vehicle floor leads to a sort of sandwich structure that could have beneficial effects on the body’s stiffness (both torsional and bending) and on the acoustical performance of the passenger compartment (better insulation).

The structural problems have already been considered in the published literature. Luttenbeger and co-workers [15] developed a study concerning the safety behavior of a battery pack in case of impact. They have considered both the frontal impact and the pole side impact according to EuroNCAP standards. The battery housing is integrated into the pre-existing body in white. They have hypothesized some lateral impact energy absorbers to be applied around the battery pack enclosures. Arora and co-workers [16] have developed a study related to the battery packaging design aimed to maximize its reliability and mitigate the safety risks in case of impact. They pay particular attention to the side impact but without developing a simulation analysis of the sketched solutions. Furthermore, the problem of the battery pack's placement is considered, and some design guidelines are proposed. Kukreja and co-workers [17] have developed a study concerning the battery pack's structure to enhance its damage-tolerant features, with particular reference to a possible frontal impact situation. Setiawan and Salim [18] have developed a specific analysis of the side impact test against a pole according to the EuroNCAP standard. In particular, they have considered two structural modifications: either a metallic foam or a honeycomb inserted into the hollow thin-walled rocker in order to enhance its lateral compression strength or a contour of thin-walled tubes to be placed around the battery pack enclosure as an energy-absorber device. Hao and co-workers [19] have developed a base study through the FE simulation of the behavior of the battery pack in case of a frontal impact. The 110 kg battery pack is placed in the front compartment under the hood and this justifies why they have concentrated their attention on the front impact event. Shui and co-workers [20] have developed a study on the battery pack enclosure through a design optimization methodology aimed to optimize some of the relevant features of its mechanical design. In particular, they have considered the minimization of mass, the maximization of minimum natural frequency, and the minimization of maximum deformation as objective functions. Navale and co-workers [21] have developed a study concerning the impact behavior of EV derived through a conversion process from a conventional vehicle. Some different cases of impact including side and pole side impact are considered. The flat battery pack and its control module are placed under the floor. To achieve an acceptable result, some modifications are introduced in some structural elements, including the floor cross-members. Furthermore, some special energy-absorbing structures are added for the door sills. In a very recent study, Pan and co-workers [22] concentrated their attention on the impact behavior of the battery pack as a component that, equipping an EV vehicle, is submitted to dangerous acceleration in case of impact. Different materials and sheet thicknesses are considered to increase the protection offered by the enclosure to the battery pack. Mortazavi Moghaddam and co-workers [23] have recently developed an analysis of an EV in case of a side pole impact as the severe load case according to ENCAP. Protection of the battery pack is improved by implementing a novel energy-absorber element into the body sill side that consists of a set of transverse conical corrugated tubes made of steel.

From the above review, the relevance of the safety problem of the EVs is clear, with particular attention to the lateral pole impact, which is more severe with respect to the lateral barrier impact. To protect the battery pack in case of impact, the above mentioned papers propose either the reinforcement of the vehicle's lateral structure (the lateral rockers or the door sills) or the addition of a sacrificial structure around the battery enclosure. None of the mentioned papers develop the idea that the protection of the battery pack is the result of the properly conceived design of the battery pack enclosure together with (in relation to) the vehicle's underbody structure (mainly the lateral rockers and the floor). This paper proposes some architectural considerations and presents some simulation results that offer evidence concerning how the interplay of the two mentioned structures is fundamental and gives some guidelines toward a collaborative design.

2. BEV Architecture and Main Structural Design Solutions

2.1. Underbody Functions

There are many principal functions and requirements of the whole vehicle underbody system; however, for the topic of this paper, the most relevant functions are as follows [2,24,25]:

- The structural function: static and dynamic strengths and stiffnesses are of crucial importance for the dynamic and NVH performance of the vehicle;
- The safety function: the underbody must contribute on the one hand to appropriate protection for the occupants, as it is an essential part of the passenger compartment, and more generally to distribute the energy absorption during impact (both frontal and lateral) events, and on the other hand, in the specific case of BEVs, to appropriate protection of the battery pack to avoid fire or explosion hazards of this component [26].

The general target is to design a light and stiff frame, because it is a fundamental part of the whole vehicle body. The body static stiffness (both bending and torsional) should be the highest possible, both for passengers' comfort and for driving precision, while keeping the mass as low as possible. General reference data for Body In White (BIW) stiffnesses are around 11 kN/mm for the bending stiffness and 1500 kNm/rad for the torsional one [24,25].

For what concerns the safety functions, the general concept is to ensure the integrity of the passenger compartment by dissipating as much of the vehicle kinetic energy as possible through progressive deformation of dedicated crumple zones. It is well known that this method has limitations, both in terms of good design practice and in the international regulations for the maximum value and dose of the deceleration the occupants can sustain without injuries. In the case of BEVs, the side impact is the most critical aspect for crash analysis, because not only the passengers but also the battery pack have to be adequately protected [22,26]. Typically, the vehicle side structures and doors have limited room for crash energy-absorbing components [27], and, in the case of BEVs where the battery pack is located in the underbody, the vehicle deck should remain nearly undeformed in order to avoid damage to the battery pack and therefore not contribute to the crash energy dissipation.

2.2. Battery System Technology

Batteries constitute the crucial and distinctive component of BEV platforms; thus, a brief note on the presently adopted battery technology and battery pack design is useful.

The vehicle battery system is a quite complex assembly as it comprises the energy storage medium, i.e., the battery cells, the structural enclosures, the temperature control (cooling) system, and an electronic device—the Battery Thermal Management System (BTMS)—which make the system supervision and the thermal and electrical safety devices based on a number of properly located sensors.

Different chemistry technologies are nowadays available for BEV batteries cells. Ding et al. provided an overview of this in their paper [10]. Electro-chemistry is the base for the development of a highly performant battery. Then, battery cells have to be manufactured. There are three main types of battery cell that are available on the market: cylindrical (Figure 1a), prismatic (Figure 1b), and pouch (Figure 1c) cells. In cylindrical cells, the anode and the cathode are winded one around the other, with a separator membrane interposed and enclosed in a steel casing. The single cell is usually relatively small, and it reaches an energy capacity lower than 20 Wh. Prismatic cells use a concept similar to the cylindrical cells, enclosing winded electrodes into an aluminum or steel enclosure with an energy capacity of around 700 Wh per cell. Finally, the pouch cells enclose the electrodes into a soft packaging, they reach an energy capacity up to 300 Wh per cell, and usually, they show the highest energy densities per unit of weight [3,13,28].

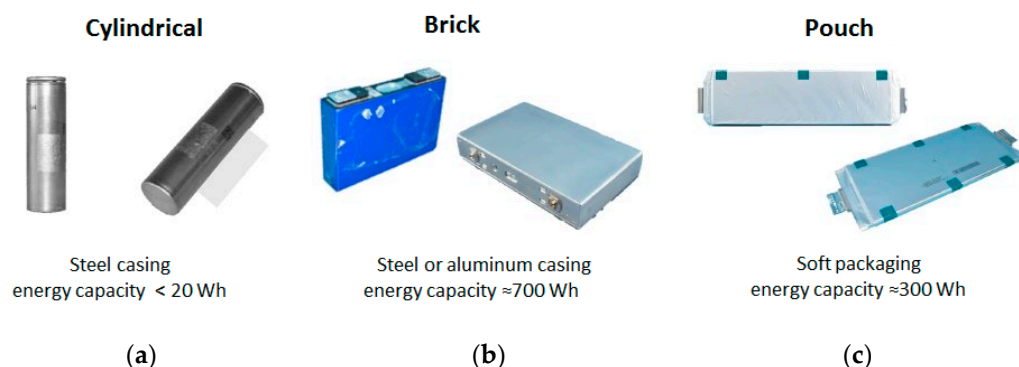

Figure 1. Comparison between different lithium battery cells, different casing external shapes ((a)—cylindrical; (b)—brick; (c)—pouch) and related storage capacities [13].

2.3. Battery Pack Enclosure

The next stage in the construction process is the integration of several cells into a battery pack structure. The main functions and critical aspects of the battery pack are listed in the following section, according to the Khajepour et al. classification [4].

- **Structural stability:** The battery pack must be designed to support the cells without affecting their operability, to be properly linked to the underbody to sustain the relevant mass of the battery cells during static and dynamic loading and granting adequate NVH performance.
- **Placement:** The battery pack should be placed as close as possible to the ground, to lower the center of gravity of the vehicle and thus not affect its dynamic riding performances. The battery placement is also crucial to determine the vehicle packaging and the vehicle's occupant ergonomics.
- **Improvement in underbody stiffness:** In the design of new HEV and BEV bodies, the battery pack is expected to contribute to the underbody structural stiffness by coupling with it to constitute a sort of sandwich structure.
- **Crash protection:** The battery pack must be placed and protected through adequate crash absorption structures; no battery case deformation is acceptable to avoid cell damages and possible fire or explosion due to cell breakage.
- **Thermal management:** The battery cells need to be maintained in the optimal operating temperature range between 25 °C and 35 °C, either by heating or cooling. This is of capital importance in order to reduce the ageing effects and to achieve the longest operative life.
- **Protection from external environment:** The battery pack must provide adequate protection from road debris and punctures to avoid damages to the cells. Adequate ground clearance and pack shielding are necessary.

In Figure 2, an example of a battery pack made of stainless steel is shown, where the different constituting elements can be identified. The battery modules are placed inside a steel case made of a deep-drawn shell and a cover, and they are separated one from the others by a grid of beams and are surrounded by a reinforcing frame, which is specifically designed for protection in case of impact. The cooling plate, which in this case, is shown in Figure 3, is made with a number of small diameter tubes and is cooled with forced flow of water; it is an essential element in terms of taking the battery pack's operating temperature under control.

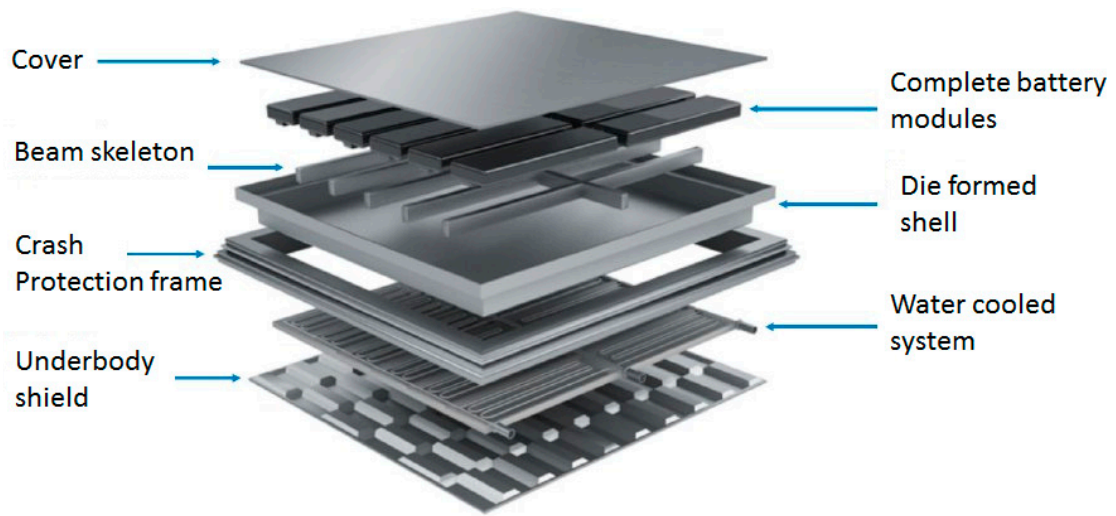

Figure 2. Stainless steel battery pack concept and typical constituting elements.

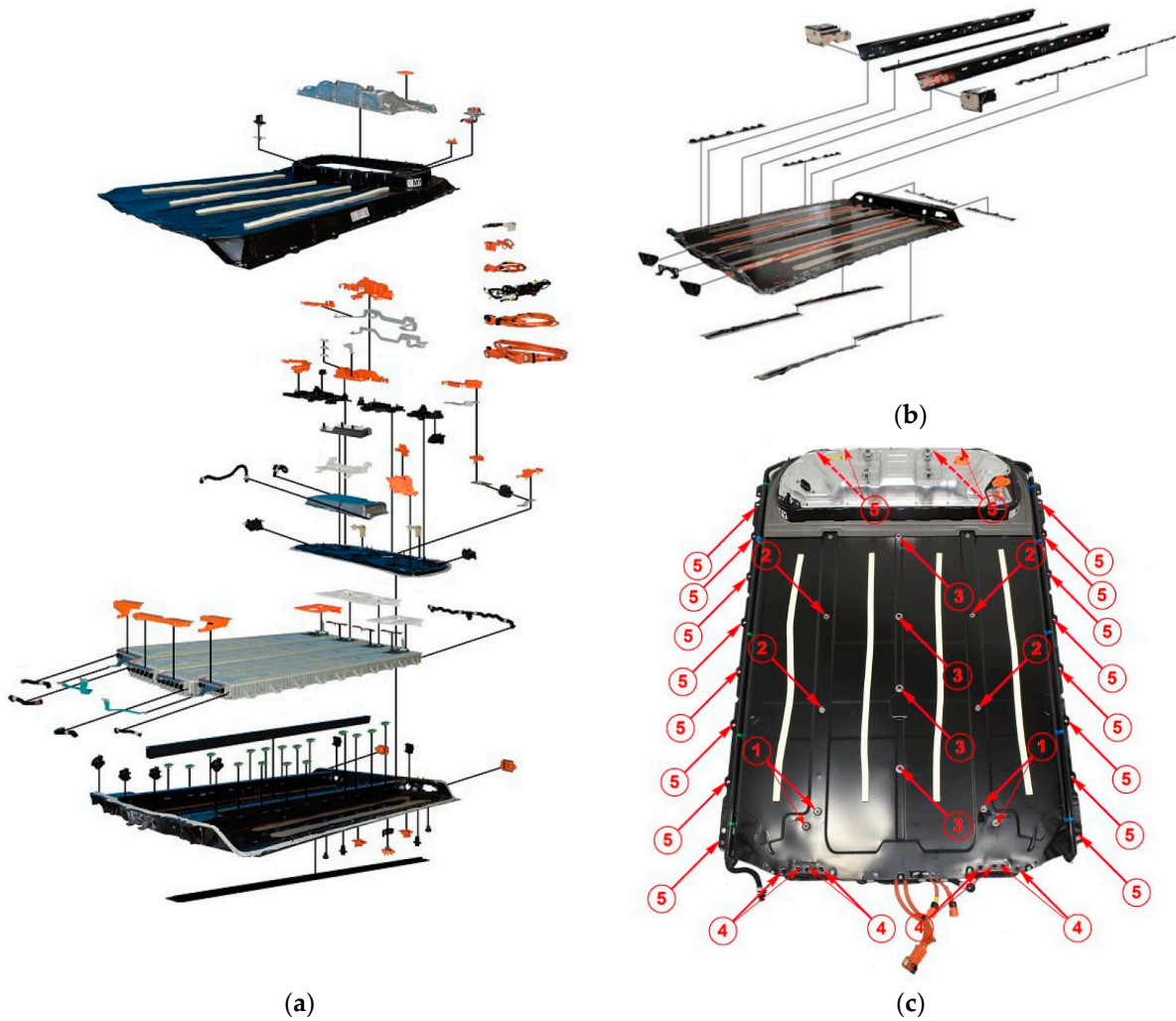

Figure 3. Examples of battery pack from Tesla Model Y-implemented solutions: (a)—exploded view of the battery pack; (b)—exploded view of the lower enclosures; (c)—the numbered red arrows show the fasteners locations [29].

2.4. Battery Pack Location and Integration

Typically, the electric powertrain accounts for at least 50% of the vehicle cost, with the battery constituting up to 35% of the overall vehicle cost; in conventional ICEVs, the powertrain accounts for approximately 16% of the vehicle cost. Further, it is worth noting that the battery weight constitutes, typically, more than one-quarter of the vehicle weight, reaching masses close to 700 kg for the complete battery pack [3,4]. It is thus crucial to focus not only on the battery's technology but also on the battery pack's structure to reduce its complexity and cost while improving its performance.

An example of the evolution of the battery pack design is shown in Figure 4, where the battery pack used by Volkswagen for their MQB platform in 2014 is compared with the newer MEB platform battery pack adopted more recently by the same manufacturer. The design philosophy is clear: in the MQB platform, the battery pack was located to use the space available in a traditional floor architecture where the longitudinal tunnel is present (see also, the study presented in [15]), while in the MEB platform, the battery pack is flat, and located under the passenger compartment floor. Simplification is easily appreciated. The new battery pack allowed VW to improve the vehicle performance and autonomy range while reducing its costs by 50%.



Figure 4. Comparison of the battery packs of VW MQB platform (left) and VW MEB platform (right).

Figure 5 shows the solution patented by Tesla for the integration of the battery pack to the underbody structure [30]; particular attention is paid to their connections. It is clear that the new underbody designs are based on the so-called skateboard architecture and they have the advantages of a sandwich-like structure. The archetype of this design was the AUTonomy, which was presented in 2002 by GM.

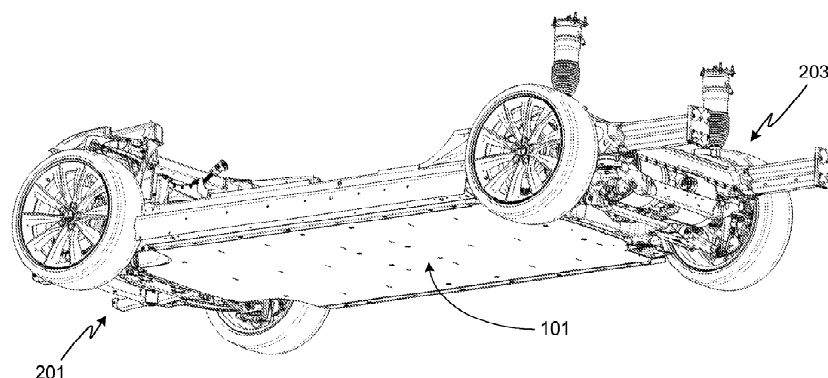

Figure 5. The solution patented by Tesla for the integration of the battery pack to the underbody structure [30].

The original GM concept evolved and was then adapted for BEV architecture. The basic idea is to have the central portion of the BIW underbody occupied by a large and mostly flat battery pack constituting the ideal board [2–4]. This enables the exploitation of the underfloor region to house the bulky battery, reducing the impact on the vehicle packaging and keeping its center of gravity low [4]. This architecture offers more flexibility to the design of the vehicle, with a simple architecture concept that is dedicated to exploit

the advantages of the BEV powertrain and cope with its challenges [4]. The crucial aspect of this architecture is the integration of the underbody structure with the battery pack in a sort of sandwich structure that guarantees high static, dynamic, and safe performances [3,4].

In Figure 6a,b, examples of two other dedicated BEV skateboard architectures from Hyundai and Ford are shown.



Figure 6. Example of two dedicated BEV skateboard architectures from Hyundai (a) and Ford (b) [29].

The solution with the battery pack positioned below the floor of the car can also be adopted in a rather similar way with commercial light duty vehicles, which typically have a completely flat floor under the storage compartment. Therefore, for this type of vehicle, small modifications to the body structure could be necessary in the transition from the ICE version to the BEV version. However, for this class of vehicles, the problems generated by the additional weight due to the battery pack and the reinforcement structures may be more important than those for passenger cars. Considering the required autonomy and the actual power density of the battery packs, the additional weight is not negligible, and this negatively affects the payload. For what concerns larger vehicles, such as trucks, the battery pack, generally, cannot be positioned as discussed up to now. In this class of vehicles, at present, there are few examples of electrification considering the required autonomy that is much larger than for the other types of vehicles. Therefore, at the moment, it is not possible to identify a standard solution. A possibility that is under development is to position the battery packs at the side of the truck frame, where the fuel tanks are positioned or at the side of the semitrailer frame.

2.5. Design Solutions for Crashworthiness and Battery Protection

As already stated, the structure should be able to offer protection both to the passengers and to the battery pack in case of a lateral impact. This result is obtained by the proper design and dimensioning of the lateral rocker, the pillars (in particular of the B one), the floor transverse beams, and the lateral door structure, while the contribution of the floor panel deformation must not be searched. The biggest effort is generally paid to the rocker structure because, in case of a lateral impact, this is first to make contact with the impacting car or the impacted pole. Typically, the rocker consists of a boxed, thin-walled beam; inside this, a room is available and it is used to obtain a proper reinforcement, as shown in Figure 7a. In order to understand the solutions implemented by the different car makers, the analyses of the cross-sections drawings and the BIW-exploded views are very helpful. Figure 7a shows an example of the rocker cross-section for the Tesla Model Y. The internal structure, an extruded longitudinal bar with three cell sections is marked with blue lines in the figure. It was specifically introduced to enhance the rocker strength and its energy-absorption capability in case of a lateral impact. Figure 7b shows, for exemplification purposes, the exploded view of the Tesla Model Y left body side assembly. The lateral rocker and the two A and B pillars are well visible.

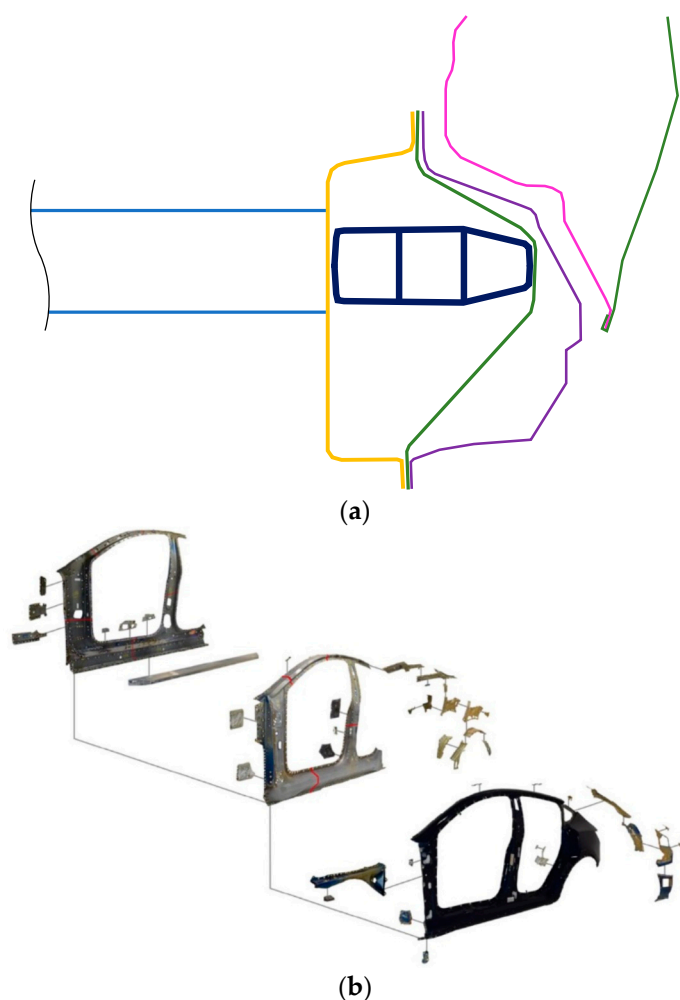

Figure 7. The cross-section of the Tesla Model Y rocker with multi-cell reinforcement inside (a) and the left side body assembly (b) [29].

The typical constitutive components and the assembly sequence are highlighted in Figure 3a. Figure 3b shows a further phase in the assembly process. The structure of the lower enclosure, which constitutes the most relevant structural component of the battery pack, is particularly evident. Lastly, Figure 3c shows the location of the fasteners that are used to join the battery pack with the underbody.

It is noteworthy that, because of the properly conceived choice of the adopted fasteners, the maintenance operation of the battery pack is relatively easy, via the detachment of the lower enclosure from the floor. Further, to increase the maintainability, access to the top rear part of the battery pack, where the electronic control unit is often positioned, could be made available under the rear seats.

Figure 8 shows the particular solution adopted by Jaguar per its I-pace model. The picture of the dedicated BEV underbody structure highlights the peculiar features of BEV platforms. With respect to the solution adopted for the corresponding ICE vehicle, the front longitudinal rails have a bigger cross-section, both because of the wider space available due to the absence of the ICE and a complex gearbox inside the engine compartment, and because of the need to dissipate a higher crash energy as a consequence of the increased vehicle weight. The floor is flat, with no or a low-profile central tunnel, and no underfloor rails are present. Since no exhaust system is present, it is possible to place a cross-member at the front part of the floor. This cross-beam may either be part of the body structure or be included into the battery pack frame. Further, it is noteworthy that the two front torque boxes and the two lateral rockers are reinforced with respect to the previous classical model design. The front torque boxes connect the front side members to the door sills.

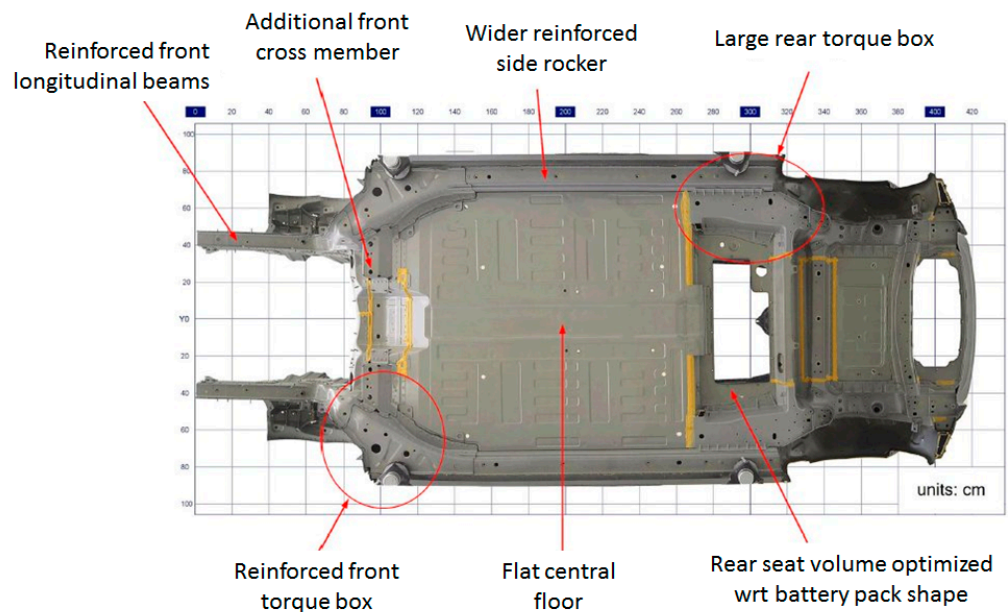

Figure 8. Jaguar I-pace underbody and main structural features of the BEV platform [29].

The side rockers are the main energy-absorbing structure in case of a side impact, and, as shown in Figure 9, they very often include inserts that are specifically designed to improve the energy-absorption capability. These inserts are generally multi-cell-extruded bars (see Figure 9A–C) made of aluminum or reinforced plastic materials, but sometimes, rockers have internal diaphragms made of stamped steel sheets (see Figure 9D) or internal diaphragms combined to constitute multi-cell-reinforcing solutions (see Figure 9E). Another solution for the rocker reinforcement has been presented in [23], where the inserted energy-absorbing structures are undulated circular tubes with the axis transverse to the rocker axis, along the impact direction.

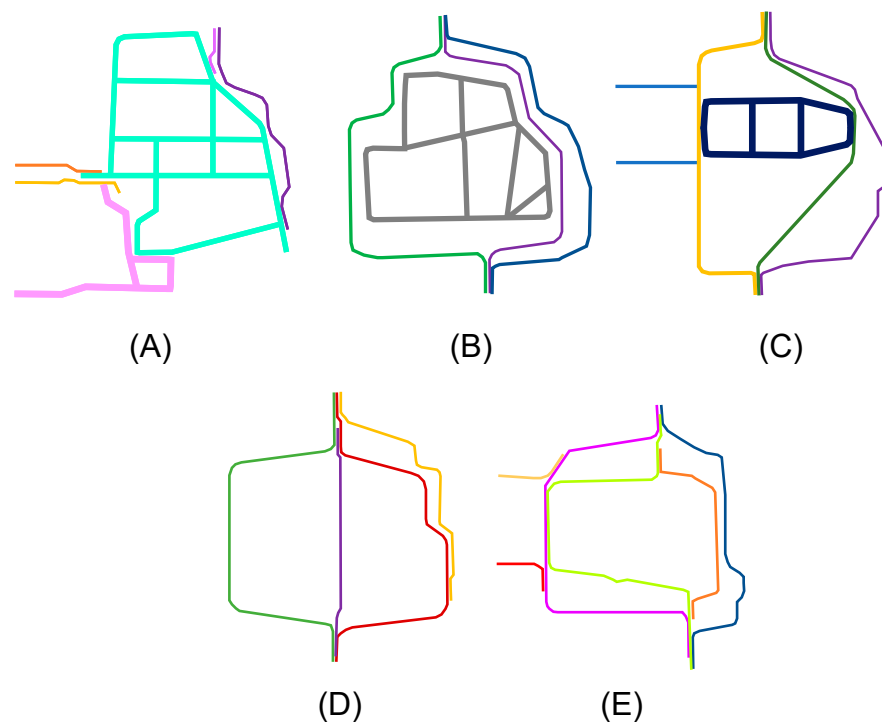

Figure 9. Five different solution: multi-cell-extruded inserts (A–C) and stamped sheet-reinforcing structures (D,E) implemented in BEVs to increment the side energy-absorption capability [29].

Figure 10 shows another example of a typical battery pack structure. Some differences are appreciable with respect to the solution already shown in Figure 2. Usually, the pack has a perimetral frame, which gives stiffness to the pack but is also intended to contribute to the crash energy-absorption performance as an addition to the side rocker's structural capability. When this frame is not present, the lower enclosure assumes the shape of a tray without the perimetral frame but with a perimetral flange to link the pack to the underbody. The most commonly used battery pack material is aluminum, which is either extruded, stamped, or casted, or alternatively, stamped steel. The perimetral frame is usually connected to the lower tray enclosure, which is then stiffened by a grid of longitudinal and/or transversal members. These members are essential for the battery module protection due to their stiffness and strength, which prevent large case deformation. The structure is completed by the top enclosure, which seals the battery pack. Sometimes the vehicle structures tend to exploit the volume under the rear seats with a battery pack protrusion that is typically dedicated to host the electronic circuits for the Battery Management System (BMS). All these structures are designed to house and protect the battery cells from external agents and impacts, as well as limiting the damages in case of a partial fire of some of the cells' modules. Another critical component of the battery pack is the cooling system, which consists of a cooling plate and cooling channels, and can be based on forced air, fluid circulation, or phase change materials.

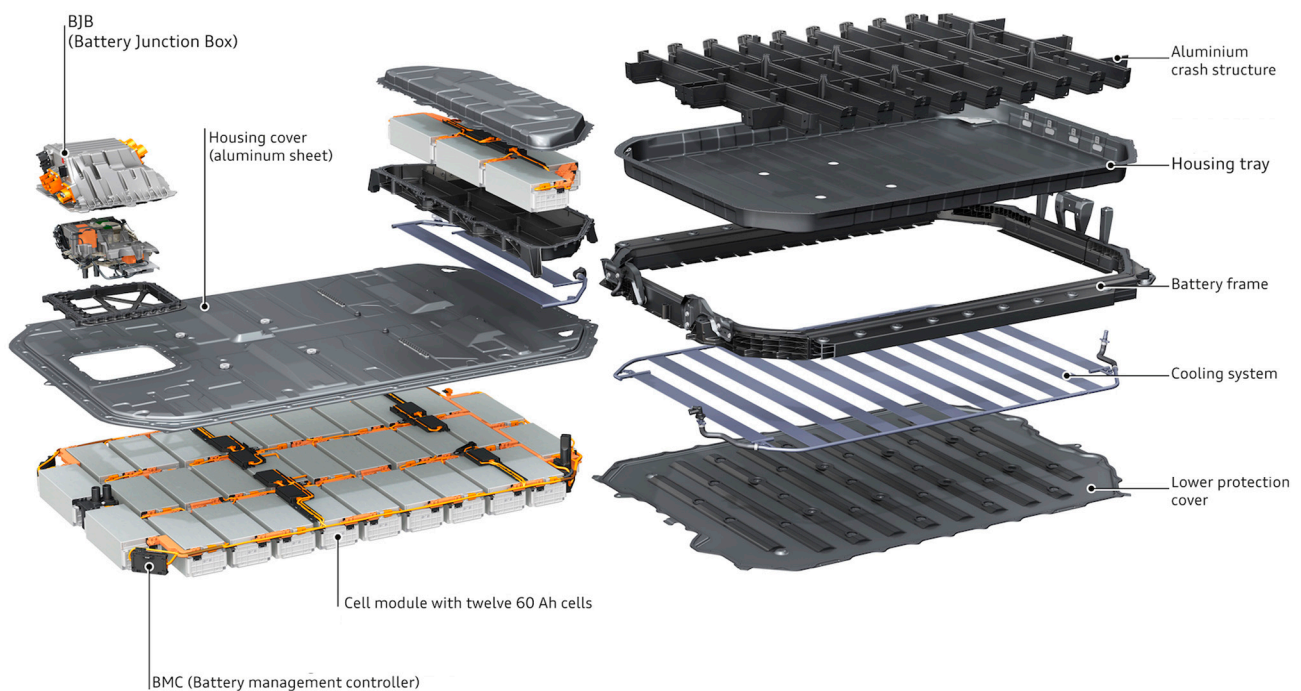

Figure 10. Constitutive elements of the Audi e-tron battery pack [31].

3. Approaches in the Crashworthiness Design

One of the challenging problems to be studied in the design phase of the described new architectural solutions for BEVs is the passive safety, with particular reference to the side impact. The side impact is not only the second type of statistical relevance in the road accident data analysis, but it is of top relevance with particular reference to the considered architecture and the concerns about possible damages of the battery pack [22,26].

The side impact suffers because of the very small space that is present in the body in the white structure where a structural device could be located with the aim of absorbing the side impact energy.

It is well known that in case of a side impact, two main test conditions are taken into account: one is related to the possible impact against another vehicle, the other one is related to the possible impact against a pole (or something similar, such as a tree). This

last condition is particularly severe because the loads are concentrated in a smaller part of the body in white, compared to the first test condition, where a large part of the vehicle's side structure is involved. This type of impact test is even more relevant for BEVs and targets that are even more stringent than in the case of traditional ICE vehicles, because of the battery pack. As already introduced, the battery pack is typically positioned in the underfloor, and it cannot be deformed in any way due to the above mentioned hazard of fire and explosion.

In these impact situations, the deck is the part of the body in white structure that is mainly involved. Some smaller contributions to the energy absorption in case of a side impact come from the B-pillar and from the door structure. The main contribution comes from the deck; therefore, the deck design had the priority. One essential component is the rocker, i.e., the lower longitudinal side member, which is typically a thin-walled, closed-section beam. Another important contribution comes from the sandwich structure, which is constituted by the passenger compartment floor and the underbody shield; sometimes, but not in all the existing solutions, the battery pack structure gives a contribution (see Figure 2) through specific structural components that are part of the battery case.

In order to match the peculiar requirements for BEVs, the rocker should be stiffer and stronger than the usual one. A typical design solution used in BEVs has already been described in Section 2.5 and it includes an extruded profile that is positioned inside the rocker, as shown in Figure 9A–C. The section and the material of this added extruded profile change from one vehicle to another according to the adopted design philosophy.

The choice of the geometry of the extruded profile, of its wall thickness and material is very influential on the global behavior; therefore, these parameters must be optimized to achieve an excellent design. This results from a careful analysis of how the geometry, the position, and the shape of the extruded profile influence, for example, the lateral load distribution on the different parts of the underbody: the upper floor, lower floor, or battery case.

A detailed design of the structural solution is made by means of a Finite Element (FE) simulation. To this aim, the authors investigated the influence of the above mentioned parameters of the rocker by means of the simplified FE model shown in Figure 11. It is a simplified generic model of the underbody for a low market segment of BEVs. It can be labeled a "generic" model because the geometries and the geometrical dimensions are not specific to a real vehicle. However, as it is possible to see in the exploded view of Figure 11b, the simplified model is made up of the main underbody components that are present in a real vehicle. All these components were simulated with shell elements. Because the target of the developed analysis is to point out the influence of the rocker cross-sections, all the components were simulated with a simple bi-linear material model representing the typical steel/aluminum used for these applications. In particular, the material parameters were defined as the average values of what is currently present in the real solutions. A benchmarking analysis enabled the definition of the yield value of 500 MPa for the steel rocker components, 270 MPa for the aluminum rocker-extruded profiles, and 280 MPa for all the other components in the model. The end cross-sections of the longitudinal rail members in the front and rear (pink and yellow components in Figure 11, respectively) are connected in a rigid way to two nodes positioned on the longitudinal x axis of the vehicle. The appropriate values of the mass and inertia were applied to these nodes in order to account for the other parts of the vehicle that were not present in the model and, therefore, to achieve the real behavior of the underbody. The parameters (geometries, dimensions, masses, and inertias) of this model were defined after a careful benchmarking analysis on the BEV vehicles on the market. With reference to a small car (B segment), the values of the masses were defined in 690 kg and 310 kg for the front and rear parts, respectively. To perform the study, the FE model was subjected to the side impact with the pole, according to the EuroNCAP regulations. Therefore, the impact angle between the longitudinal vehicle centerline and the pole velocity was set to 75° , whereas the initial velocity of the pole was set to 32 km/h [32]. During the simulated test, the deformations, the forces transmitted, and the energies absorbed by the different components were measured and recorded. The

deformations were measured as the compression of spring elements positioned along the transverse axis of the vehicle at the impact point considering their longitudinal position. The forces were measured with the cross-sections positioned as the spring elements. The energies absorbed by the different components were measured as the internal energy in the simulation.

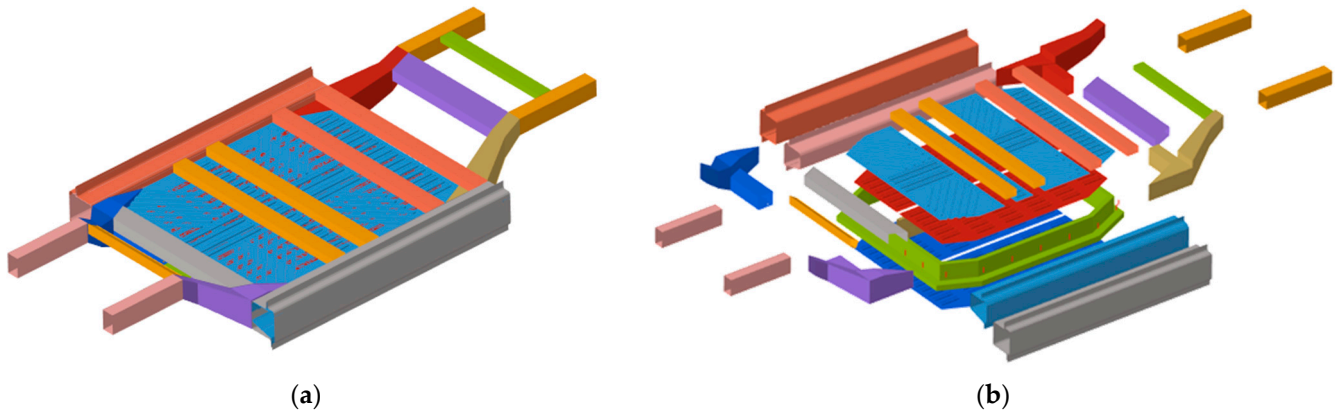

Figure 11. (a) Simplified generic model of the underbody for a low segment BEV. (b) The exploded view of the underbody model.

The influence of the geometry of the extruded profile inserted into the rocker is highlighted in Figure 12a, where the time history of the energy absorbed by the battery case is shown for three different rocker solutions studied in the work. The cross-sections of the rocker used in these considered solutions are shown in the figure. These three solutions are representative of the possible solutions that are present in the market. The solution with the black border in Figure 12a is a traditional solution, whereby the rocker is reinforced with an internal septum in stamped steel sheets. In the other two cross-sections, the rocker is reinforced with an extruded profile made of aluminum. In the green border solution, the extruded profile fills all the cross-section, whereas in the blue border solution, the extruded profile is localized in a part of the cross-section. A smaller value of the energy to be absorbed by the battery case means better energy absorption by the rocker. The influence of the position of the aluminum-extruded profile on the value of impact lateral loads can be deduced from Figure 12b, where the time history of the load, separately on the floor and on the battery pack, is reported for two different rocker reinforcement solutions. In this case, the traditional solution that is completely made of stamped steel sheets was not considered because it was outside the scope of the analysis. The cross-sections of the rocker used in these two considered solutions are shown in the figure. Once again, a smaller value of the force applied to the battery pack means a better solution.

On the other hand, it is of interest to analyze the effect of changes in the wall thicknesses of the extruded profile because, if their values are too high, the stiffness of this part will be too high compared with the nearer components and it will not deform (thus it will not absorb energy) or deform slightly (thus, it will absorb a little amount of energy) during the impact. In Figure 13a, the time histories of the impact deformation of the rocker are reported for the same internal reinforcement solution but with two different wall thicknesses. As a consequence of a too stiff solution, all the loads will be rigidly transmitted to the battery pack (Figure 13b). This is not what the structural designer desires to achieve, as this will probably result in relevant damage to the battery pack.

As a conclusion of this part of the study, the interplay between the compressive stiffness of the vehicle's lateral structure (and in particular, of the rocker and its internal reinforcing structure) with the lateral stiffness of the battery case is evident. When the internal reinforcement is not occupying the whole section of the rocker, it is important to properly select its location and eventual clearance.

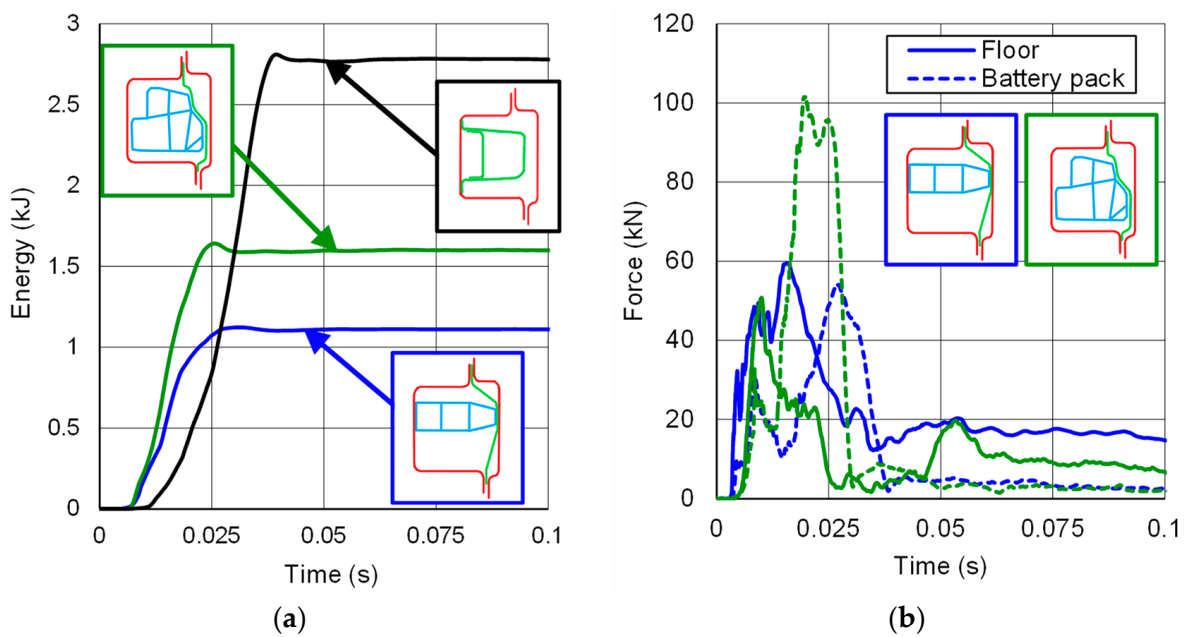

Figure 12. FE results of the pole side impact on the simplified underbody model: energy absorbed by the battery case (a), and lateral loads on the floor and battery case (b).

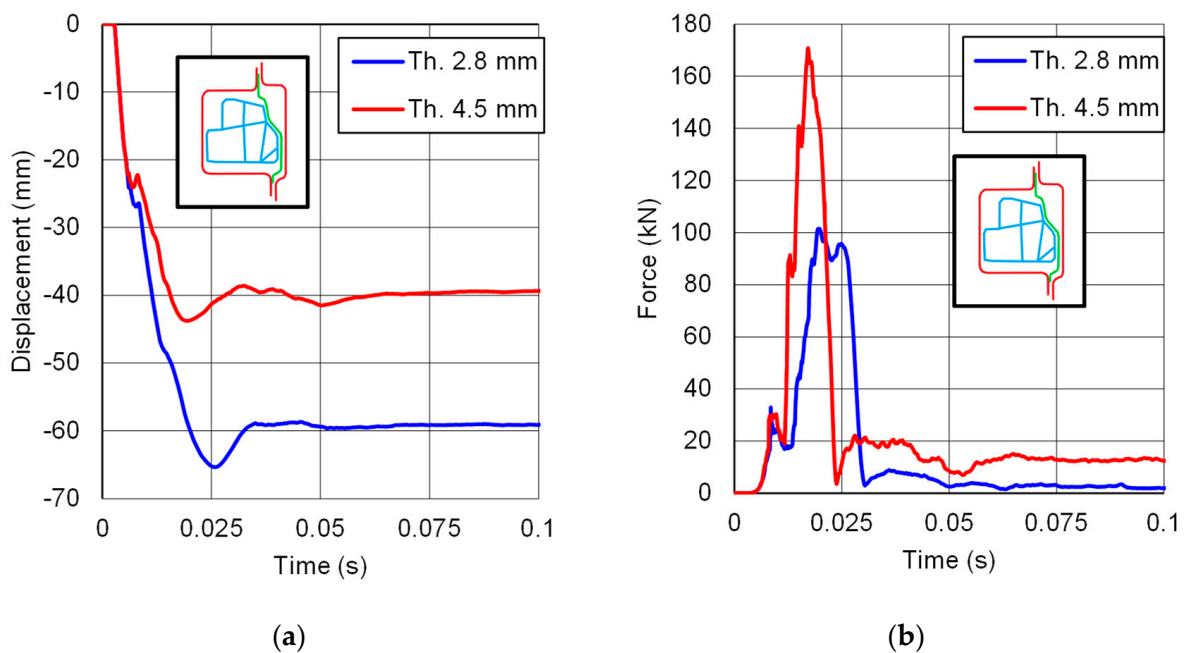

Figure 13. FE results of the pole side impact on the simplified underbody model: side deformation of the rocker (a), and force transmitted to the battery case (b).

As a consequence of the changes in the structure, the global dynamic behavior of BEVs during a side crash is different with respect to the usual ICEVs. Being the lower longitudinal member stiffer, the vehicle tends to have a higher rolling rotation around the longitudinal axis, because there is less deformation of the lower structure, as it is possible to see in Figure 14, where the responses of the same vehicle equipped either with a traditional internal combustion engine or with an electrical powertrain and submitted to the pole impact test are compared. Consequently, the upper part of the BEV structure (in particular the B-pillar and the upper beam that constitute the roof longitudinal member) is involved in the impact, making contact with the pole.

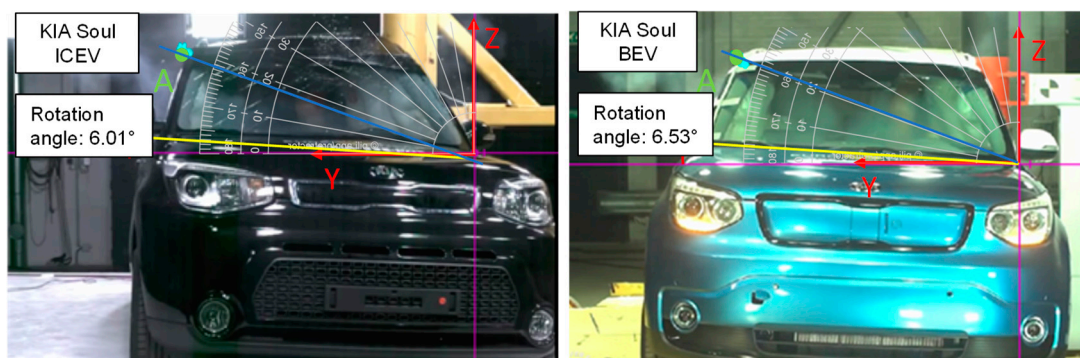

Figure 14. Maximum rotation angle along the longitudinal axis of the same vehicle (KIA Soul) equipped with different powertrain configurations (ICEV and BEV) evaluated during the pole side impact.

4. Conclusions

The evolution toward electric vehicles nowadays appears to be the main stream in the automotive and transportation industries. This choice is expected to have a beneficial impact on climate change and on the pollution of the air, especially inside our towns; however, as discussed in this paper, it is really challenging to develop feasible, effective solutions to relevant problems in the BEV design.

This innovative type of vehicle, equipped with an electrical powertrain system and related specific controls, may have an insufficient autonomy problem. A solution for this is given by strong increments of the dimension and capacity of the on-board battery pack and through the development of technologies to dramatically increase the rapidity of battery recharging operations.

Our attention has been focused on the architectural modifications that should be introduced into the car body to give a proper location to the battery pack. The required battery pack is no longer a simple, relatively cheap brick to be located in the engine compartment, but it is a big, heavy, and expensive component to be located, managed, climatized, maintained, and protected.

After a detailed overview of the published literature on the specific subject, we presented some engineering analyses together with an overview of sketches of some possible solutions for the above-listed points.

Taking into account the weight of the battery pack required for new BEVs, in order to avoid a relevant change in the location of the vehicle center of gravity that in turn could affect the vehicle's drivability, it is generally accepted that the battery housing should be located below the passenger compartment floor. This solution is very interesting from the point of view of the battery pack's protection in case of a front, lateral, or rear impact and for easy serviceability and maintenance.

The integration of the battery pack housing structure and of the vehicle floor leads to a sort of sandwich structure that could have beneficial effects on the body's stiffness (both torsional and bending).

This paper proposes some considerations related to the impact protection of the battery pack, with particular reference to the side impacts against another vehicle and against a fixed obstacle, such as a pole, which demonstrate themselves to be the most critical condition. Three different solutions for the reinforcement of the lateral rocker are considered. One consists of a traditional internal septum, and the other two consist of extruded profiles inserted inside the rocker. The reported results of the FE analysis, carried out with a simplified model, demonstrate the effectiveness of the different possible solutions for reinforcement placed inside the rocker, and the importance of the proper choice of wall thickness in the interplay among the different parts of the vehicle side structure and battery case structure.

Author Contributions: Conceptualization, G.B.; methodology, G.B. and A.S.; software, A.S.; validation, A.S.; formal analysis, G.B.; investigation, G.B. and A.S.; resources, G.B. and A.S.; data curation, A.S.; writing—original draft preparation, G.B.; writing—review and editing, G.B. and A.S.; visualization, A.S.; supervision, G.B.; project administration, G.B. and A.S.; funding acquisition, A.S. All authors have read and agreed to the published version of the manuscript.

Funding: This research received no external funding.

Conflicts of Interest: The authors declare no conflict of interest.

References

1. Ritchie, H. Cars, planes, trains: Where do CO₂ Emissions from Transport Come From? 2020. Available online: <https://ourworldindata.org/co2-emissions-from-transport> (accessed on 26 September 2020).
2. Ehsani, M.; Gao, Y.; Emadi, A. *Modern Electric, Hybrid Electric, and Fuel Cell Vehicles: Fundamentals, Theory, and Design*; CRC Press: Boca Raton, FL, USA, 2009.
3. Emadi, A. *Advanced Electric Drive Vehicles*; CRC Press: Boca Raton, FL, USA, 2014.
4. Khajepour, A.; Saber Fallah, M.; Goodarzi, A. Body and Chassis Technologies. In *Electric and Hybrid Vehicles: Technologies, Modeling and Control—A Mechatronic Approach*; John Wiley & Sons: Hoboken, NJ, USA, 2014.
5. Belingardi, G.; Scattina, A. Integrated Underbody and Battery Pack for Battery Electric Vehicles: Challenges and Solutions in the Design. In Proceedings of the 9th International Congress Motor Vehicles and Motors (MVM 2022), Kragujevac, Serbia, 13–14 October 2022.
6. Zhang, X.; Chan, S.H.; Ho, H.K.; Tan, S.-C.; Li, M.; Li, G.; Li, J.; Feng, Z. Towards a smart energy network: The roles of fuel/electrolysis cells and technological perspectives. *Int. J. Hydrog. Energy* **2015**, *40*, 6866–6919. [[CrossRef](#)]
7. Hoekstra, A. The Underestimated Potential of Battery Electric Vehicles to Reduce Emissions. *Joule* **2019**, *3*, 1412–1414. [[CrossRef](#)]
8. Yang, L.; Yu, B.; Yang, B.; Chen, H.; Malima, G.; Wei, Y.M. Life cycle environmental assessment of electric and internal combustion engine vehicles in China. *J. Clean. Prod.* **2021**, *285*, 124899. [[CrossRef](#)]
9. Yu, X.; Sandhu, N.S.; Yang, Z.; Zhen, M. Suitability of energy sources for automotive application—A review. *Appl. Energy* **2020**, *271*, 115169. [[CrossRef](#)]
10. Ding, Y.; Cano, Z.P.; Yu, A.; Lu, J.; Chen, Z. Automotive Li-Ion Batteries: Current Status and Future Perspectives. *Electrochem. Energy Rev.* **2019**, *2*, 1–28. [[CrossRef](#)]
11. Engel, H.; Hertzke, P.; Siccardo, G. *Second-Life EV Batteries: The Newest Value Pool in Energy Storage*; McKinsey & Company: New York, USA, 2019.
12. Han, X.; Lu, L.; Zheng, Y.; Feng, X.; Li, Z.; Li, J.; Ouyang, M. A review on the key issues of the lithium ion battery degradation among the whole life cycle. *eTransportation* **2019**, *1*, 100005. [[CrossRef](#)]
13. Saldaña, G.; San Martín, J.I.; Zamora, I.; Asensio, F.J.; Oñederra, O. Analysis of the Current Electric Battery Models for Electric Vehicle Simulation. *Energies* **2019**, *12*, 2750. [[CrossRef](#)]
14. Bobba, S.; Mathieux, F.; Ardente, F.; Blengini, G.A.; Cusenza, M.A.; Podias, A.; Pfrang, A. Life Cycle Assessment of repurposed electric vehicle batteries: An adapted method based on modelling energy flows. *J. Energy Storage* **2018**, *19*, 213–225. [[CrossRef](#)]
15. Luttenberger, P.; Ostrowski, M.; Kurz, M.; Sinz, W. Structural analysis of a body in white for battery integration using finite element and macro element with the focus on pole crash optimization. In Proceedings of the European Congress on Computational Methods in Applied Sciences and Engineering (ECCOMAS 2012), Vienna, Austria, 10–14 September 2012.
16. Arora, S.; Shen, W.; Kapoor, A. Review of mechanical design and strategic placement technique of a robust battery pack for electric vehicles. *Renew. Sustain. Energy Rev.* **2016**, *60*, 1319–1331. [[CrossRef](#)]
17. Kukreja, J.; Nguyen, T.; Siegmund, T.; Chen, W.; Tsutsui, W.; Balakrishnan, K.; Liao, H.; Parab, N. Crash analysis of a conceptual electric vehicle with a damage tolerant battery pack. *Extrem. Mech. Lett.* **2016**, *9*, 371–378. [[CrossRef](#)]
18. Setiawan, R.; Salim, M.R. Crashworthiness design for an electric city car against side pole impact. *J. Eng. Technol. Sci.* **2017**, *49*, 587–603. [[CrossRef](#)]
19. Hao, F.; Lu, X.; Qiao, Y.; Chen, X. Crashworthiness analysis of electric vehicle with energy-absorbing battery modules. *J. Eng. Mater. Technol.* **2017**, *139*, 021022-1. [[CrossRef](#)]
20. Shui, L.; Chen, F.; Garg, A.; Peng, X.; Bao, N.; Zhang, J. Design optimization of battery pack enclosure for electric vehicle. *Struct. Multidiscip. Optim.* **2018**, *58*, 331–347. [[CrossRef](#)]
21. Navale, A.B.; Chippa, S.P.; Chougule, D.A.; Raut, P.M. Crashworthiness aspects of electric vehicle design. *Int. J. of Crashworthiness* **2021**, *26*, 368–387. [[CrossRef](#)]
22. Pan, Y.; Xiong, Y.; Dai, W.; Diao, K.; Wu, L.; Wang, J. Crush and crash analysis of an automotive battery-pack enclosure for lightweight design. *Int. J. of Crashworthiness* **2022**, *27*, 500–509. [[CrossRef](#)]
23. Mortazavi Moghaddama, A.; Kheradpishehband, A.; Asgari, M. An integrated energy absorbing module for battery protection of electric vehicle under lateral pole impact. *Int. J. Crashworthiness* **2022**, *27*, 1–13. [[CrossRef](#)]
24. Zhang, J.; Hu, S.; Guo, X.; Zhou, Q. Multidisciplinary design optimization of BEV body structure. *SAE Tech. Pap.* **2015**, *26*, 0229.

25. Park, D.; Jeong, S.H.; Kim, C.W.; Yang, H.W.; Kim, D.S.; Choi, D.H. Material arrangement optimization for weight minimization of an automotive body in white using a bi-level design strategy. *Proc. Inst. Mech. Eng. Part D J. Automob. Eng.* **2016**, *230*, 395–405. [[CrossRef](#)]
26. Ascurra, J.; Luzzi, F.; Panfili, A.; Masoero, G.L.; Puppini, R.; Stolcis, L.; Belingardi, G.; Scattina, A. Underbody design for Battery Electric Vehicles. In Proceedings of the International Automotive Body Congress IABC, Torino, Italy, 22–23 June 2022.
27. Belingardi, G.; Jindong, J. Crashworthiness evaluation of composite vehicle side door with an innovative design. *Int. J. Automot. Compos.* **2016**, *2*, 75–93. [[CrossRef](#)]
28. Løbberding, H.; Wessel, S.; Offermanns, C.; Kehrer, M.; Rother, J.; Heimes, H.; Kampker, A. From cell to battery system in BEVs: Analysis of system packing efficiency and cell types. *World Electr. Veh. J.* **2020**, *11*, 77. [[CrossRef](#)]
29. Available online: <https://www.a2mac1.com/> (accessed on 15 April 2022).
30. Rawlinson, P. Underbody for a Motor Vehicle. U.S. Patent US-8286743-B2, 16 October 2012.
31. Available online: https://www.greencarreports.com/news/1116347_audi-details-battery-for-2019-e-tron-electric-suv (accessed on 15 April 2022).
32. Euro NCAP—Oblique Pole Side Impact Testing Protocol, Version 7.0.2, November 2015. Available online: <https://cdn.euroncap.com/media/20874/oblique-pole-side-impact-test-protocol-v702.pdf> (accessed on 15 February 2023).

Disclaimer/Publisher’s Note: The statements, opinions and data contained in all publications are solely those of the individual author(s) and contributor(s) and not of MDPI and/or the editor(s). MDPI and/or the editor(s) disclaim responsibility for any injury to people or property resulting from any ideas, methods, instructions or products referred to in the content.