

Life cycle assessment of the biofuel production from lignocellulosic biomass in a hydrothermal liquefaction - aqueous phase reforming integrated biorefinery

*Original*

Life cycle assessment of the biofuel production from lignocellulosic biomass in a hydrothermal liquefaction - aqueous phase reforming integrated biorefinery / Zoppi, G; Tito, E; Bianco, I; Pipitone, G; Pirone, R; Bensaid, S. - In: RENEWABLE ENERGY. - ISSN 0960-1481. - 206:(2023), pp. 375-385. [10.1016/j.renene.2023.02.011]

*Availability:*

This version is available at: 11583/2977936 since: 2023-04-14T08:44:51Z

*Publisher:*

PERGAMON-ELSEVIER SCIENCE LTD

*Published*

DOI:10.1016/j.renene.2023.02.011

*Terms of use:*

This article is made available under terms and conditions as specified in the corresponding bibliographic description in the repository

*Publisher copyright*

(Article begins on next page)

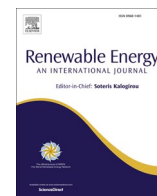

# Life cycle assessment of the biofuel production from lignocellulosic biomass in a hydrothermal liquefaction – aqueous phase reforming integrated biorefinery

Giulia Zoppi<sup>a</sup>, Edoardo Tito<sup>a</sup>, Isabella Bianco<sup>b</sup>, Giuseppe Pipitone<sup>a,\*</sup>, Raffaele Pirone<sup>a</sup>, Samir Bensaid<sup>a</sup>

<sup>a</sup> Department of Applied Science and Technology, Politecnico di Torino, Corso Duca degli Abruzzi 24, 10129, Turin, Italy

<sup>b</sup> Department of Environment, Land and Infrastructure Engineering, Politecnico di Torino, Corso Duca degli Abruzzi 24, 10129, Turin, Italy

## ARTICLE INFO

### Keywords:

Advanced biofuel  
Aqueous phase reforming  
Biorefinery  
Hydrothermal liquefaction  
Life cycle assessment

## ABSTRACT

The use of biofuels in the transport sector is one of the strategies for its decarbonization. Here, the LCA methodology was used for the first time to assess the environmental impacts of a biorefinery where hydrothermal liquefaction (HTL) and aqueous phase reforming (APR) were integrated. This novel coupling was proposed to valorize the carbon loss in the HTL-derived aqueous phase, while simultaneously reducing the external H<sub>2</sub> demand during biocrude upgrading. Corn stover (residue) and lignin-rich stream (waste) were evaluated as possible lignocellulosic feedstocks. The global warming potential (GWP) was 56.1 and 58.4 g CO<sub>2</sub> eq/MJ<sub>biofuel</sub>, respectively. Most of the GWP was attributable to the electrolysis step in the lignin-rich stream case and to the thermal duty and platinum use in the corn stover case. Other impact categories were investigated, and an uncertainty analysis was also carried out. A sensitivity analysis on biogenic carbon, electricity/thermal energy source and alternative hydrogen supply was conducted to estimate their influence on the GWP. Finally, the two scenarios were compared with the environmental impact of fossil- and other biomass-derived fuels, also considering fuel utilization. HTL-APR allowed a 37% reduction compared to fossil diesel, further reduced to 80% with the lignin-rich stream when green energy was used.

## 1. Introduction

Trucking, shipping and aviation are likely the most difficult sectors to decarbonize, with few low-carbon technology options. In this framework, biofuel production seems a strategic choice for its capacity of decreasing the net anthropogenic greenhouse gas emissions [1].

Among the possible technologies, hydrothermal liquefaction has gained attention thanks to its ability to deal with wet biomass, avoiding the energy-expensive drying step. Its main product is called biocrude, a fuel-like organic phase, with a high calorific value (32–44 MJ/kg) and an oxygen content between 5 and 30 wt% [2]. In addition to this product, an aqueous, a gaseous and solid phase are obtained. This results in a selectivity issue, as most of the carbon could be lost in phases other than biocrude. Among the cited by-products, the aqueous phase (HTL-AP) is particularly critical for two main reasons. Firstly, up to 35% of the carbon in the feed ends up in a diluted stream (typical concentration values are within 0.4–2 wt. C%) [3,4]; secondly, wastewater

treatment can be very expensive, resulting in a high impact on the biofuel cost [5]. Therefore, the valorization of this stream is pivotal for the HTL scalability both from an economic and environmental point of view, as recently reported by several reviews on this topic [6–8].

Another issue that needs to be addressed for the success of hydrothermal liquefaction regards the adequacy of the biocrude properties. Due to its high heteroatoms content (mainly oxygen), it cannot be directly used in conventional engines without upgrading. This is usually performed by catalytic hydrogenation at high temperature and pressure. Since the required hydrogen is commonly produced by steam reforming of natural gas, renewable options are needed to reduce the need for fossil sources in biorefineries [9].

A possible solution to both limitations (i.e., carbon loss in the HTL-AP and need for renewable hydrogen) could be aqueous phase reforming (APR). APR is a catalytic reaction able to produce hydrogen starting from oxygenated compounds dissolved in water, working at mild pressure and temperature directly in the liquid aqueous phase [10]. Thermodynamically, APR exploits the greater tendency of these compounds

\* Corresponding author.

E-mail address: [giuseppe.pipitone@polito.it](mailto:giuseppe.pipitone@polito.it) (G. Pipitone).

<https://doi.org/10.1016/j.renene.2023.02.011>

Received 26 October 2022; Received in revised form 1 February 2023; Accepted 3 February 2023

Available online 4 February 2023

0960-1481/© 2023 The Authors. Published by Elsevier Ltd. This is an open access article under the CC BY-NC-ND license (<http://creativecommons.org/licenses/by-nc-nd/4.0/>).

**Abbreviation list**

AP	Acidification Potential
APR	Aqueous Phase Reforming
CS	Corn Stover
EP	Eutrophication Potential
FDP	Fossil Depletion Potential
GWP	Global Warming Potential
HTL	Hydrothermal Liquefaction
LCA	Life Cycle Assessment
LRS	Lignin-Rich Stream
SR	Steam Reforming
TEA	Techno-Economic Assessment
wb	Wet basis

(e.g., alcohols) to be converted into hydrogen and carbon dioxide compared to alkanes. This results in lower operating temperature and hence an energy advantage over steam reforming; in addition, water gas shift is also favored, so that negligible CO concentration can be reached in the effluent gas through a one-pot process. Usually, the reaction is carried out using a noble metals catalyst, mostly platinum, in order to activate C–C bond breaking reaction and water gas shift [11]. Glycerol is one of the most studied compounds for APR, due to its overproduction in the biodiesel industry; moreover, other simple molecules such as methanol, ethylene glycol or sorbitol were investigated in several works [12]. During the last years, there was also a growing interest in the application of APR to more complex feedstocks, but several issues remain unclear at present [13].

Despite the potential synergies that can be exploited through the HTL-APR integration [14–16], APR is not commonly explored in the available literature for the valorization of HTL wastewater. Previous works of the authors proved that some classes of compounds can be successfully converted into hydrogen; for example, the water fraction from HTL of a lignin-rich stream was characterized and tested to produce hydrogen via APR [17,18]. Di Fraia et al. reported that almost half of the hydrogen that could be required for biocrude upgrading can be obtained from the aqueous phase [19]. The hydrogen need of biocrude can vary with the heteroatoms content: Zhu et al. reported 0.033 g H<sub>2</sub>/g biocrude (HTL of woody biomass) [5], while 0.041 g H<sub>2</sub>/g biocrude is necessary in the case of HTL of algae [20]. In this sense, the coupling of HTL and APR has been proposed as a valuable option to increase the carbon efficiency of the whole process by providing on-site biocrude upgrading [19].

In order to proceed with the industrial implementation of these technologies, it is necessary to verify that technical, economic and environmental sustainability criteria are satisfied. A techno-economic assessment conducted by the authors pointed out the technical and economic feasibility of an HTL-APR integrated plant [21]. Two cases were evaluated based on two different lignocellulosic feedstocks: corn stover (CS) and lignin-rich stream (LRS). The biofuel minimum selling prices (MSPs) were 1.23 and 1.27 €/kg for biofuel for LRS and CS, respectively, resulting comparable with costs of other biofuels present in the market. Furthermore, for the CS-case the hydrogen produced by APR was 107% of that required for the biocrude upgrading, resulting in a very competitive hydrogen production cost through APR of 1.5 €/kg. Despite the technical and economic indicators demonstrated the beneficial synergy of the HTL-APR plant, the environmental performances must also be evaluated. Even if it is a renewable source (i.e., biomass), the sustainability of the technology is yet to be determined. Therefore, a cradle-to-gate life cycle assessment (LCA) has been herein performed starting from material and energy streams of an HTL-APR biorefinery.

Currently, life cycle assessment (LCA) is one of the most accepted methodologies for quantifying the potential environmental impacts of a

product during all the phases of its life. LCA is standardized by ISO 14040 and ISO 14044 and is defined as the “compiling and the evaluation of the inputs and the outputs and the potential environmental impacts of a product system during a product life time” [22,23]. These guidelines have been further detailed by the ILCD (International Reference Life Cycle Data System) Handbook and the PEF (Product Environmental Footprint) guidelines [24,25].

Only a few LCAs regarding HTL [26,27] and APR [28] are present in literature, while, to the best of the authors’ knowledge, such an evaluation has never been performed for an HTL-APR plant. However, for the reasons stated above, evaluating such biorefinery configuration is worthy of investigation due to important highlighted synergies. By filling this gap, the environmental assessment could help recognize technological bottlenecks which have to be overcome to ensure compliance with environmental sustainability criteria.

The quantification of the environmental impact was carried out by investigating two different scenarios, discriminated by the nature of feedstock (corn stover or lignin-rich stream derived from a 2nd generation bioethanol plant). Furthermore, in order to provide an indication on the uncertainties involved in the assessment of a low-TRL process, a preliminary uncertainty analysis was performed using Monte Carlo simulations. A sensitivity analysis was carried out by examining the influence of certain methodological choices such as biogenic carbon, electricity/thermal energy source and plant configuration for hydrogen supply on the LCA indicators. The results of the present work highlight the potential environmental benefits and burdens of a biorefinery for advanced biofuel production, supporting future discussion for its implementation in the industrial sector.

## 2. Methodology

### 2.1. Case study description

The nameplate capacity of the biorefinery was set at 20 MW for the lignin-rich stream (LRS) and 16.5 MW for the corn stover (CS), so that the feed flowrate for each scenario was 3.6 t/h (dry basis). This flowrate is coherent with the size of a second-generation bioethanol plant and the biomass availability of corn within a radius of 50 km, respectively. The corn stover is collected and transported by trucks to the gate of the biorefinery, while the LRS was assumed to be in proximity of the bioethanol plant. Fig. 1 shows a simplified block flow diagram for each scenario investigated in this work. The biomass is ball milled for size reduction and mixed with water to bring the biomass content to 10 wt% (feedstock preparation); once the operating conditions are reached (200 bar, 350 °C), it enters the HTL reactor. At the outlet, the four phases are separated: the solid phase is first removed at high temperature in order to reduce biocrude losses, the gaseous compounds are then removed by a low-pressure flash, while the oil and aqueous phase are separated in a centrifuge. The gas phase is sent directly to a torch, due to its low heating value; the solid phase is energetically valorized in a furnace to provide heat; the biocrude is sent to the upgrading section (hydro-treatment - HT), while the aqueous phase is sent to the APR reactor, where hydrogen is produced. The gaseous output of APR is separated in a pressure swing adsorption unit (PSA). The CO<sub>2</sub>-rich stream is sent to a torch; the H<sub>2</sub>-rich stream, is sent to the hydrotreatment reactor where the biocrude is upgraded into an advanced biofuel with suitable properties. Due to the partial efficiency of the upgrading section, light alkanes are also obtained, which are energetically valorized in a furnace.

The material and energy balances, as well as the design of the main equipment, were performed in a separate work [21], and the main results are reported in Figs. S1 and S2 of the Supplementary Information. Please note that in the case of lignin-rich stream, an electrolyzer provides the necessary H<sub>2</sub> make up for the complete upgrading of biocrude.

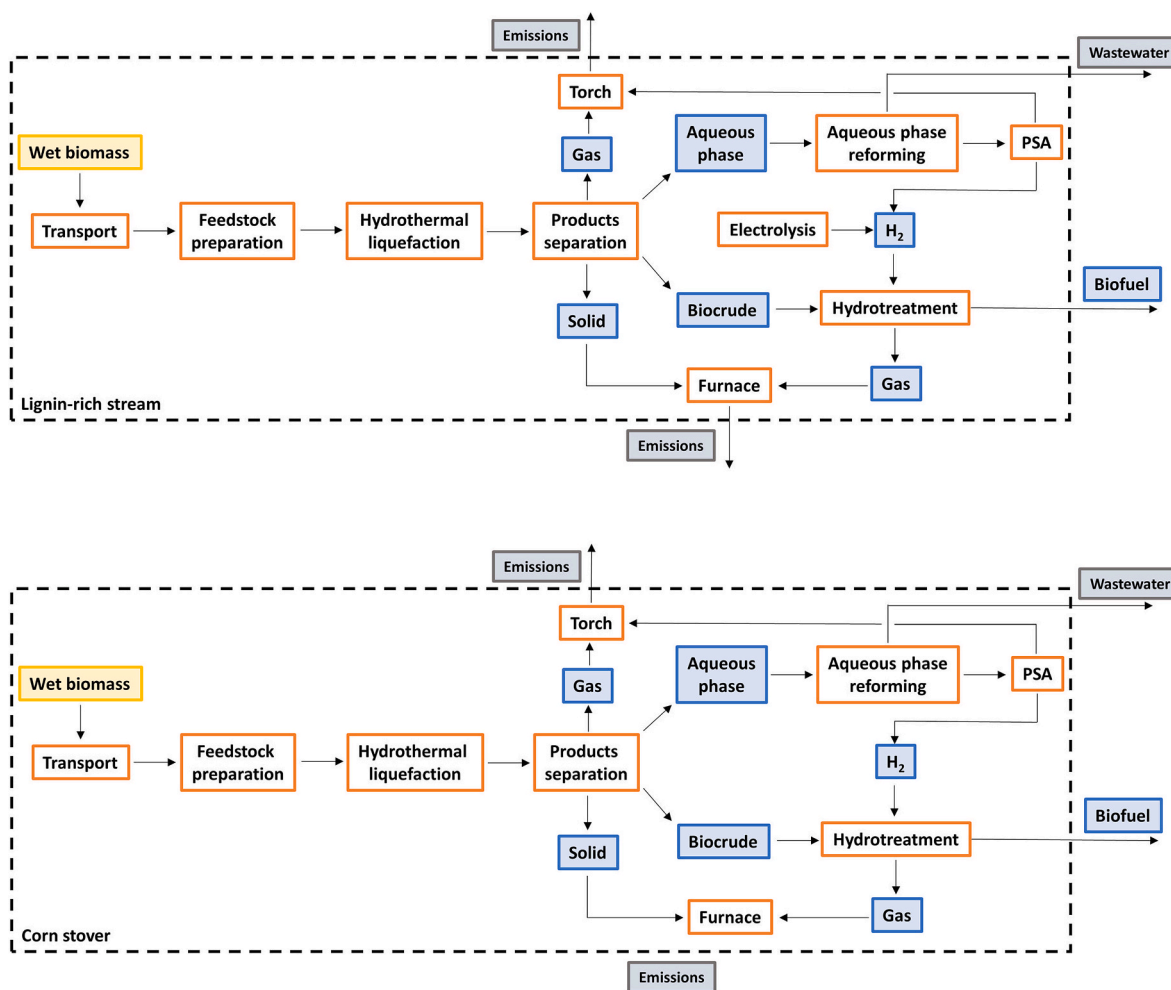

Fig. 1. System boundaries of the HTL-APR biorefinery for lignin-rich stream and corn stover feedstock.

## 2.2. Goal and scope definition

During this first stage, all general decisions are made (e.g., functional unit, system boundaries, allocation procedure etc.).

The goal of this work was to assess the environmental impacts of producing advanced biofuels from LRS or CS feedstocks through a combined HTL-APR plant. An attributional cradle-to-gate LCA was developed, following the approach reported in Ref. [29]. The system boundaries comprehend the processes from the feedstock collection to the biofuel production (Fig. 1), while its utilization is out of the scope of the assessment. The transport and use phase of biofuel were considered only for the GWP quantification to enable a comparison with fossil fuels. Since the function of biofuel is to provide energy, 1 MJ of biofuel was chosen as functional unit, as recommended by EU RED [30]. Its properties (water and ash content, elemental composition, etc.) are assimilable to those of a diesel, and 43 MJ/kg is considered its lower heating value. The plant location was assumed to be in Europe.

When dealing with the LCA of biomass, it is crucial to define its nature: in other words, it should be determined whether it is an energy crop, a residue or a waste [31]. The lignin-rich stream was assumed to be a waste; it is a by-product of a 2nd generation bioethanol plant, and its residual value can be considered zero. On the other hand, corn stover must be considered a residue. It is left on the field after corn harvesting and its value derives from its contribution to soil organic matter [31]. For this reason, land use change aspects, such as the impact deriving from harvesting and replacement of soil nutrients, were accounted in the CS-case [32].

In the LRS-case the HTL-derived biofuel was the only product, and no allocation was required. In the CS-case, in addition to the HTL-derived biofuel, a surplus hydrogen stream was produced by the APR process. In order to take into account these two products, different allocation methods were investigated, namely on a mass-, energy- and economic-basis. However, in all cases the impact related to the hydrogen product was negligible. Under a mass-basis, the hydrogen flowrate was only 0.4% of the biofuel flowrate (2.9 kg/h vs 841 kg/h); under an energy-basis, the hydrogen power was 1% of the biofuel power (being  $H_2$  LHV = 120 MJ/kg and biofuel LHV = 43 MJ/kg); under an economic-basis, hydrogen counted for 1.1% of the biofuel value (assuming the  $H_2$  selling price as green  $H_2$  – 5 €/kg – and the biofuel selling price as the one derived in our previous TEA – 1.62 €/kg [21]). For all these reasons, it emerges that the impacts obtained in the CS-case can conservatively be attributed to the biofuel production only.

Cut-off criteria for materials and construction energy were considered to perform the LCA, in accordance with the literature and the ILCD Handbook guidelines. To this end, a cut-off of 1% of total mass was applied; this assumption was confirmed by performing a preliminary assessment (on the materials required for the construction of the equipment, the hydrotreating catalyst and make-up streams) which resulted in an impact of less than 0.5% in each impact category. For this reason, they were not taken into account hereafter. On the other hand, the impact of replacing the APR catalyst (Pt/C) was evaluated due to its higher environmental footprint.

Four impact categories were considered for the environmental characterization.

- Global warming potential (GWP): this impact category has been chosen due to the importance of climate change mitigation in the current European and international policies.
- Acidification potential (AP): it is one of the most investigated impact category in the literature [31]. It refers to the release of acid rain precursors.
- Eutrophication potential (EP): it is due to the discharge of nutrients (e.g., phosphorous and nitrogen) into the environment, which eventually leads to a potential loss of biodiversity.
- Fossil depletion potential (FDP): it is related to the extent to which non-renewable resources are used. Herein, they were considered as reciprocally substitutable fossil fuels (i.e., oil, natural gas and coal) with equal characterization factor. Its evaluation is critical to assess the actual reduction of fossil fuel depletion when considering biofuels.

Therefore, this work does not only take into account the environmental burden derived from greenhouse gas emissions, as sometimes reported for other biofuels-related works [33,34], but expands its investigation to other categories which are considered particularly important in addressing the environmental footprint of a biofuel [35]. The use of a limited set of impact categories seems also justified by other works [32,36]. For the same reason, CML 2001 baseline (version 2016) method was used to facilitate the comparison with impacts from the literature.

When dealing with biomass, an important discussion point is the assessment of biogenic carbon, which is emitted as CO<sub>2</sub>, CO or CH<sub>4</sub> directly attributable to biomass. These emissions might be not considered, as they are derived from the carbon that has been sequestered during its growth, thus resulting in a net zero impact. However, a consensus on the most appropriate way to consider biogenic carbon in LCA has still not been reached. An issue is the lag time between uptake and release of CO<sub>2</sub>, which is particularly severe when dealing with long-rotation period biomass.

In this work, the climate change impact results are given without taking into account the biogenic carbon emissions, following the “0/0 approach” (neither uptake from the environment nor emissions). Further evaluation on the influence of this assumption will be reported in the sensitivity analysis.

### 2.3. Inventory analysis

Table 1 depicts the life cycle inventory related to 1 MJ of advanced biofuel for the corn stover and lignin-rich stream scenarios. In Table 1 the datasets used from GaBi as secondary source are reported. The primary data on biocrude yield, hydrogen production from APR, mass and energy balance were collected from experimental results of the authors [21]. In addition, some assumptions or literature data have been necessary to fill some inventory gaps. In particular,

- The lignin-rich stream was assumed to be a waste, so no environmental burden was associated with it. Corn stover was assumed to be a residue, so impacts deriving from transport and harvesting were taken into account. Biomass transport was considered equal to a 50 km distance covered by truck. The impact due to harvesting was modelled taking into consideration the diesel used for corn stover collection and the use of fertilizer to replace soil nutrients (NPK 15-15-15 from GaBi database) [32];
- For background processes (e.g., thermal and electric energy by European mix), data from GaBi Database were used. The cooling power was converted from thermal to electrical energy, as described in technical literature [37]. Natural gas was chosen as the thermal energy source;
- The electric grid mix used in this work consisted of various sources: fossil fuels (41.5%), nuclear (27.6%), wind (8.0%), hydro (12.8%)

**Table 1**

Life cycle inventory of 1 MJ biofuel for LRS and CS cases.

Inputs/ Outputs/ Emissions	Item	LRS- case	CS- case	Unit	Dataset
Inputs	Diesel for harvesting	–	0.023	MJ	Diesel mix at refinery (EU-28)
	Fertilizer replacement	–	0.90	g N	NPK 15-15-15 (nitrophosphate route, 15N–15P2O5–15K2O) (EU-28)
	Biomass transport	–	50	km	Truck, Euro 6, 28 - 32t gross weight/22t payload capacity (GLO)
	Feedstock (wb)	0.27	0.11	kg	–
	Process water	0.017	0.26	kg	Process water (EU-28)
	Hydrogen	1.2	0	g	Modelled according to Ref. [39] for electrolysis; Hydrogen steam reforming (DE) for SR
	Electricity	0.095	0.025	kWh <sub>el</sub>	Electricity grid mix (EU-28)
	Heating	0.020	0.098	kWh <sub>th</sub>	Thermal energy from natural gas (EU-28)
	Cooling	0.094	0.10	kWh <sub>th</sub>	Modelled according to [37]
	Platinum (APR catalyst)	0.39	0.65	mg	Modelled according to [41]
Output	Biofuel	23	23	g	–
	Hydrogen	0	0.08	g	–
Emissions	CO <sub>2</sub>	55	38	g	–
	Ash	0.40	1.0	g	Municipal solid waste on landfill (EU-28)
	Wastewater	0.22	0.31	kg	Wastewater treatment (EU-28)

and others (e.g., solar, geothermal, etc.). This distribution is similar to the one reported by the European Commission for the 2019 [38];

- The CO<sub>2</sub> equivalent flue gas emissions were attributed to the combustion of char, HTL- and APR-derived gas, PSA and HT-derived off-gas. The carbon dioxide production from char and off-gas combustion was calculated based on stoichiometry and complete conversion;
- The environmental performance of electrolysis for hydrogen production was obtained from mass/energy balances from literature [39]; the environmental performance of steam reforming (SR) when used for hydrogen production was taken from GaBi database;
- The catalyst lifetime (platinum-based) was set at 1 year, lower than other assumptions reported in the literature [40], as a conservative measure. The data for platinum impact were taken from the literature based on 28% platinum recycling [41].

An uncertainty analysis was carried out to evaluate the confidence of the obtained results due to intrinsic uncertainties related to key variables (i.e., biofuel yield, required hydrogen for upgrading, thermal duty, electric duty, APR catalyst demand and wastewater treatment). In order to reach this objective, Monte Carlo simulations with 10 000 iterations were performed by simultaneously modifying the variables with a triangular distribution within a chosen range and the obtained results were depicted by box and whisker plots.

### 3. Results and discussion

#### 3.1. Impact assessment and interpretation

In Table 2 the chosen impact categories for the entire HTL-APR biorefinery are summarized for the two evaluated scenarios; the main contributions of each impact category are presented in Fig. 2. It is important to emphasize that the results reported in this paragraph are highly dependent on the methodological choices depicted above [42], i. e., 1 MJ of biofuel as functional unit, cradle-to-gate system boundaries, single product, exclusion of biogenic carbon emissions. Paragraph 3.3.1 will be devoted to exploring this last aspect in more detail.

Fig. 2A shows that GHG emissions are similar between the two cases; however, the distribution between the different impact items is different. Regarding the cumulative LRS-GWP, electrolysis is responsible for 56% of the overall impact, while the second highest impact is due to catalyst replacement (17%), which is platinum-based. Electricity (for mixing, pumping and centrifugation) and thermal energy account for 14% and 8%, respectively. The electricity grid mix used in this work resembles the average share found in the EU and consists mainly of fossil sources. It derives, for example, that our hypothesis on the location of the plant strongly affects the results of our assessment. In this sense, Ögmundarson et al. showed that electricity-demanding facilities are hardly determined by the regional mix [43]. The necessity of using electricity brings an environmental burden unless renewable energy sources are strongly deployed. Further evaluations on this topic are reported in paragraph 3.3.2.

Platinum has a significant impact on GWP (as well as on each other impact category). As mentioned above, it derives from our assumption of a conservative lifetime, equal to 1 year, which is lower than other assumptions reported in the literature [40]. Furthermore, it must be recalled that a 28% recycling of platinum was assumed.

There are few works in the literature that address the impact of catalyst in the LCA of biofuels, and it is sometimes considered negligible [44]. On the other hand, we highlight here that a noble metal catalyst, such as the one used for APR, strongly affects the environmental performance, due to the complex, costly and energy-intensive mining process. This is a hot topic for the research and development stage, as it calls for the formulation of noble metal-free catalysts.

On the other hand, thermal energy represents 40% of the total GWP impact for the CS, with the remaining 27% and 18% attributed to platinum and electricity, respectively. The higher thermal duty is due to the lower production of char (during HTL) and alkanes (during upgrading). These by-products are burned to provide a fraction of the heating energy required by the biorefinery. In the CS-plant is thus required a higher supply of natural gas that causes the discussed difference with respect to the LRS-plant. The supply of heat by natural gas ensures a low impact (240 g CO<sub>2</sub> eq/kWh) with respect to other fossil sources such as heavy fuel oil (320 g CO<sub>2</sub> eq/kWh) and coal (380 g CO<sub>2</sub> eq/kWh). 8% of the CS-impact is also attributable to corn stover harvesting and transport to the plant.

The fossil depletion potential is equal to 0.64 (LRS) and 0.83 (CS) MJ eq/MJ; this means that for every MJ of biofuel produced, 64% and 83%, respectively, is attributable to fossil resources. The most impacting item for the LRS-case is electrolysis (52%) and it is due to the fossil fuels used to produce electricity. On the other hand, thermal power is the most

impacting item for the CS-case (48%), due to its high thermal demand compared to the LRS-case. Platinum is also quite impacting (20% and 25% for LRS and CS, respectively), as well as electricity (13% for both cases).

The acidification potential is higher for the CS-case (Fig. 2C) and is mostly due to the replacement of the platinum catalyst (66% and 85% for LRS and CS, respectively). This is attributable to the environmental impact of platinum extraction and purification [45]. The higher SO<sub>2</sub> eq observed for platinum in the CS-case is attributable to its higher platinum/biofuel ratio (338 mg Pt/kg biofuel vs. 557 mg Pt/kg biofuel). The difference between the two cases is due to catalyst replacement and it is partially offset by the impact of electrolysis in the LRS-case (24%). This is due to the SO<sub>2</sub> emissions derived from fossil fuel-based thermo-electrical plants [46]. The impacts due to electricity and thermal energy are limited and are both due to the sulfur content present in fossil fuels.

Finally, the eutrophication potential results very similar in the two cases, and wastewater treatment had the highest impact in both of them (66% and 62% for LRS and CS, respectively). This is due to the chemical oxygen demand (COD) and total nitrogen (TN) left in the wastewater to be treated. Platinum (11% and 19% for LRS and CS, respectively) and electrolysis (16% for LRS) also had remarkable impact. The latter is attributed to the emissions of nitrogen oxides emissions due to the presence of nitrogen (i.e., fuel NO<sub>x</sub>) and the elevated temperatures reached during the combustion process (i.e., thermal NO<sub>x</sub>) of fossil fuels required for electricity generation. For the CS-case, the impact of nitrogen fertilizer to be replaced due to corn stover removal from field amounted to 6%, while electricity to 5%, as well as thermal energy. As for the impact of harvesting, it is worthy of attention that this outcome is affected by the chosen system boundary (i.e., starting from the cradle) and the decision of taking into account the land use change derived from the removal of the stover. For the LRS-case, electricity accounted for 4%.

In the end, the transport of the feedstock (CS) from the collection point to the biorefinery was found to be negligible for each impact category under the hypothesis reported in paragraph 2.3.

#### 3.2. Uncertainty analysis

Since HTL and APR are promising but still emerging technologies, LCA results can suffer from process uncertainties and lack of reliable data that can be obtained when commercial plants are in operation [47]. Nevertheless, its potential to estimate most of the environmental issues related to a process already at the design stage makes it an effective tool, if uncertainties are properly reported [48]. Different types of uncertainties can be detected during LCA, associated to systematic errors, model, non-linear processes, parameters, etc. [49]. In this section, we focused on the last category. In order to compensate for these uncertainties, we carried out a Monte Carlo simulation to get an insight into the range of possible variations if the key variables, identified in the previous paragraph, change. The assigned uncertainties were ±15% for electricity, thermal power and wastewater, ±30% for platinum demand, ±10% for biofuel yield from hydrotreatment and ±20% for hydrogen demand at hydrotreatment. These uncertainties often derive from the accuracy level of the design method and the intrinsic TRL of the process block; in addition, the importance of catalyst has been often overlooked [50]. Please note that, in the CS-case, particular attention must be paid to the hydrogen demand for hydrotreatment. In fact, APR would be able to provide hydrogen up to a +7% variation; for larger uncertainties, the use of an electrolyzer was supposed. The Monte Carlo simulation results are given in Fig. 3 for each impact category and feedstock analyzed in this work. With regards to GWP (Fig. 3A), the percentage deviations range from −13 to +11% for LRS and from −11 to +9% for CS. The greater variation for the former could be attributed to its higher dependence on the hydrogen requirement. The FDP for corn stover (Fig. 3B) was always higher than that of the lignin-rich stream, even considering the 5th (0.75 MJ eq/MJ) and 95th percentile (0.72 MJ eq/MJ), respectively. With regards to AP (Fig. 3C), the percentage

**Table 2**  
Environmental impacts of the HTL-APR biorefinery for LRS and CS scenarios (1 MJ biofuel).

	Unit	LRS	CS
Global warming potential	g CO <sub>2</sub> eq/MJ	56.1	58.4
Fossil depletion potential	MJ eq/MJ	0.64	0.83
Acidification potential	mg SO <sub>2</sub> eq/MJ	380	486
Eutrophication potential	mg PO <sub>4</sub> eq/MJ	52.1	51.8

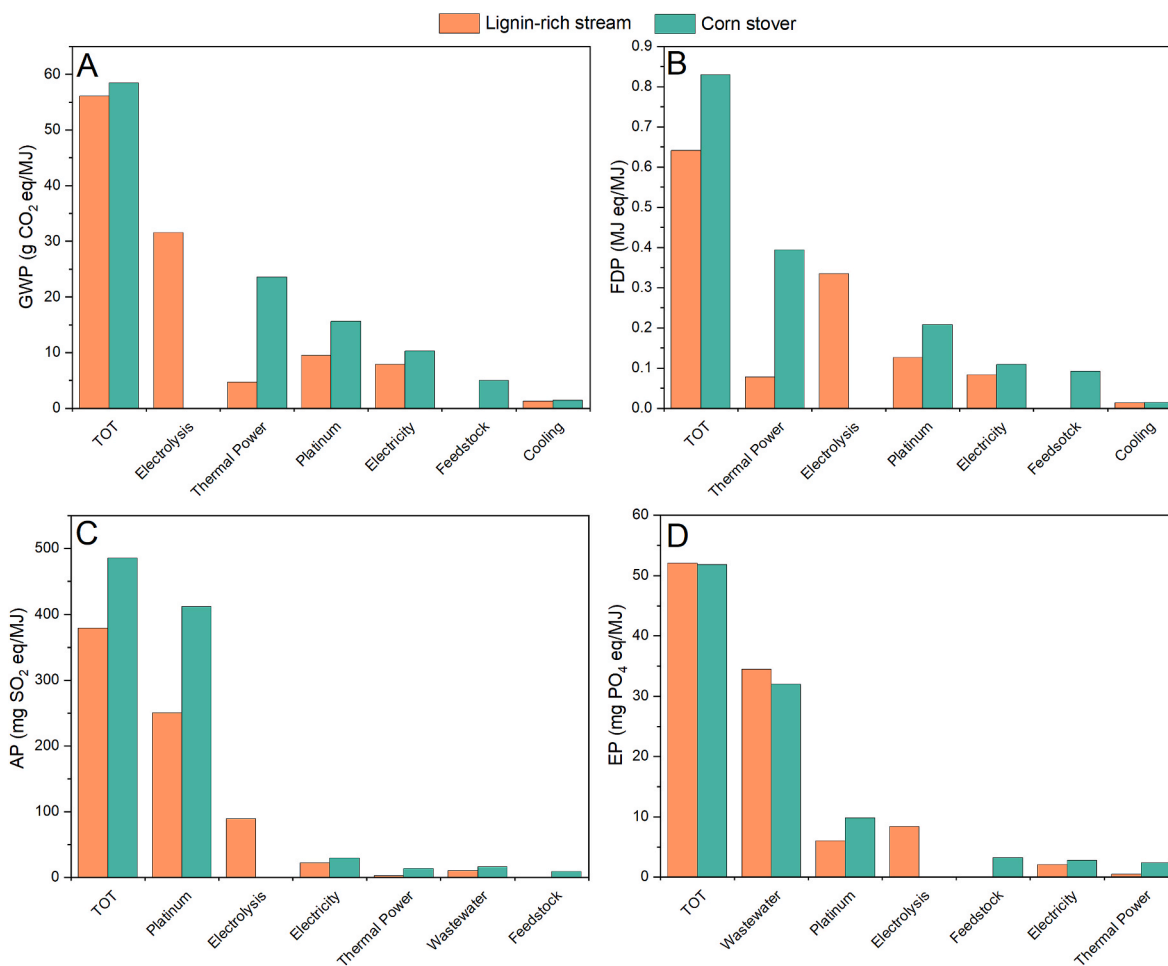

**Fig. 2.** Distribution of GWP (A), FDP (B), AP (C) and EP (D) among the main processes. Please note that the sum of impacts of harvesting and transport of the biomass is reported as ‘feedstock’.

deviations range from  $-15$  to  $+16\%$  for LRS and from  $-18$  to  $+19\%$  for CS. The greater variation for the latter could be ascribed to its high dependency on the platinum consumption, which is the variable with the highest variation in this analysis ( $\pm 30\%$ ). Finally, Fig. 3D depicts the uncertainties related to the EP, for which similar variations were found for both feedstocks ( $\pm 11\%$ ). This result is attributed to the similar impact distribution between the items for both cases, wastewater treatment and platinum being similarly responsible for eutrophication.

### 3.3. Sensitivity analysis

From the observed results, most of the environmental burden is attributed to the electrolysis in the LRS-case, while it is more distributed in the CS-case. In the next paragraphs, a sensitivity analysis is presented to consider: (i) the non-biogenic nature of biomass; (ii) the influence of different sources of electrical and thermal energy; (iii) alternative plant configurations for hydrogen supply.

#### 3.3.1. Non-biogenic carbon

As reported in the methodology section, the global warming potential of the HTL-APR biorefinery was evaluated following the “0/0 approach”, that is, considering biomass as a carbon-neutral energy resource. However, an agreement on the way to treat biogenic carbon is still not reached in LCA [51]. This is because the one-time pulse related to the CO<sub>2</sub> emissions from biomass combustion remains in the atmosphere and can therefore affect the delicate equilibrium of greenhouse effect. For this reason, in this paragraph the GWP including the biogenic

carbon is presented.

Fig. 4 shows how the GWP changes with the addition of biogenic carbon. In the LRS-case, ca. 27 g CO<sub>2</sub> eq/MJ biofuel are related to the torch emissions, and ca. 28 g CO<sub>2</sub> eq/MJ biofuel are attributed to the furnace. The former are caused by the CO<sub>2</sub>-rich gas phases derived from HTL and PSA, which do not have sufficient heating value to justify their use in a furnace, but at the same time cannot be released into the atmosphere due to the presence of harmful greenhouse gas (e.g., methane). The latter is ascribed to the burning of char and HT-derived gas phase to recover heat. As a result, the cumulative GWP increases from 56 to 111 g CO<sub>2</sub> eq/MJ biofuel (+98%). In the CS-case, the GWP also increases from 58 to 96 g CO<sub>2</sub> eq/MJ biofuel (+64%). It can be observed that a lower impact (8.8 g CO<sub>2</sub> eq/MJ) is due to the furnace section in the CS-case due to the lower amount of char combusted, while the amount of gas phase from HTL and APR is approximately the same as in the LRS-case.

These values represent the actual release of CO<sub>2</sub> eq into the atmosphere, but they should be considered as a worst-case scenario for the environmental assessment of biomass processing, as no information is provided regarding the source of carbon. Since the feedstocks examined in the present case studies are residue/waste from fast-growing biomass, their embedded carbon was previously absorbed by the plant as CO<sub>2</sub> from the environment. If the feedstock carbon would be accounted as CO<sub>2</sub> credit, from mass balances it would theoretically amount to 162 and 159 g CO<sub>2</sub> eq/MJ. It would hence result in an overall negative cradle-to-gate CO<sub>2</sub> eq emission, according to a “-1/1 approach” that does not take into account the fuel use.

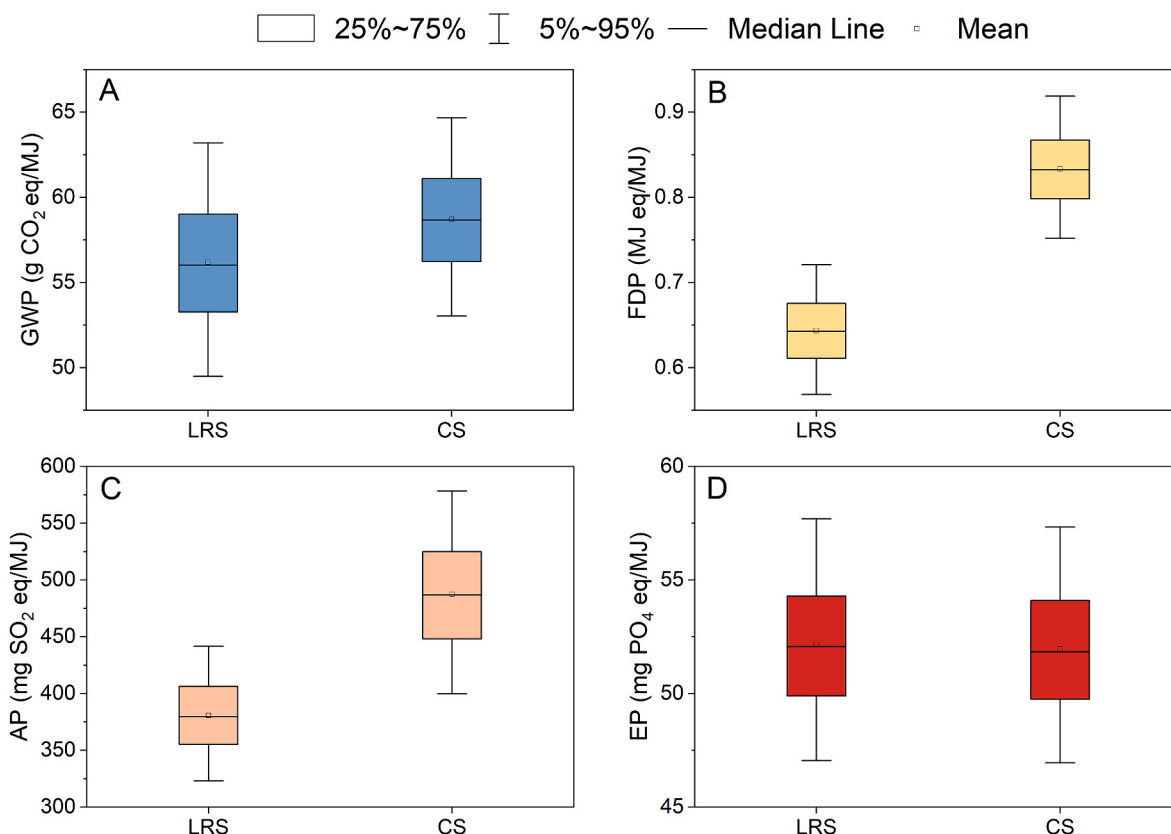

Fig. 3. Uncertainty results of the four impact categories for the two feedstocks scenarios investigated.

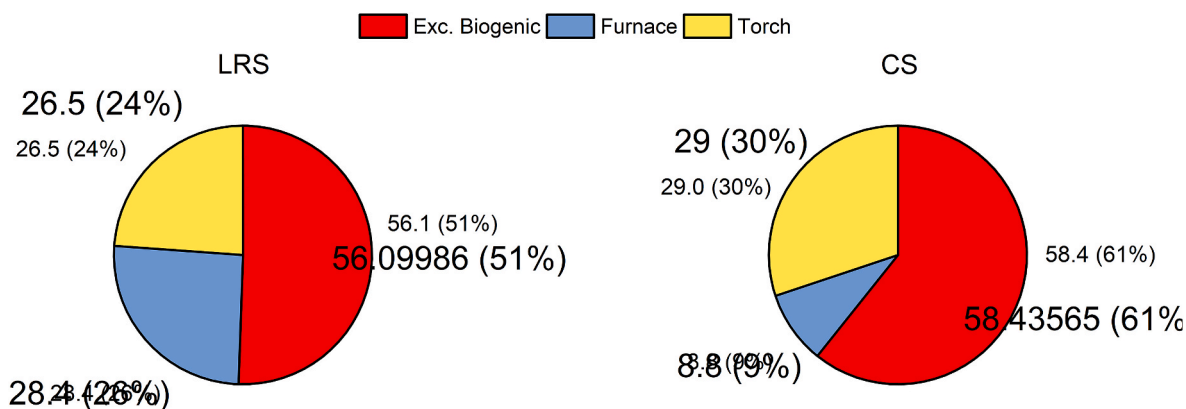

Fig. 4. Influence of biogenic carbon on cumulative GWP for the LRS-case (left) and CS-case (right). The numbers are referred to the g CO<sub>2</sub> eq/MJ biofuel, while the percentage with respect to the total value is reported in brackets.

### 3.3.2. Energy sources

As reported above, the electrolysis unit (in the LRS-case) and the heating unit (in the CS-case) have a significant impact on the overall global warming potential. This is not directly correlated with the running of the electrolysis itself, but rather to the source of electricity used to carry out the water splitting. For this reason, it is interesting to evaluate greener and renewable options. To this end, wind, photovoltaic, hydro and biomass-based electricity, as well as biomass-based heating system were evaluated (Fig. 5).

Each of the renewable sources leads to a decrease in the GWP. As for electricity, in the LRS-case it ranges from a 71% reduction with hydro-power and wind to a 42% reduction with biogas; on the other hand, the CS-case is less influenced by the change in electricity, with the reduction of the impact ranging between 8 and 16%. This result is a direct

consequence of the GWP related to the production of 1 kg of hydrogen. In literature it was reported that wind-based electrolysis is generally the best method, from an environmental point of view, followed by hydro-electricity [52]. In this work, the GWP related to electrolysis via grid mix resulted equal to 26 kg CO<sub>2</sub>/kg H<sub>2</sub>, similar to values reported in the literature [52]. This value is even higher than the H<sub>2</sub> production through natural gas-based steam reforming. An in-depth comparison will be performed in the paragraph 3.2.3. It is interesting to observe that by employing renewable sources for electricity production, the LRS-case becomes more environmentally sustainable than the CS-case. This is because the latter, being self-sufficient in terms of hydrogen production, has a much lower electricity demand and hence is less affected by the type of electricity used.

The greatest reduction in impact (34%) for the CS-case is reached

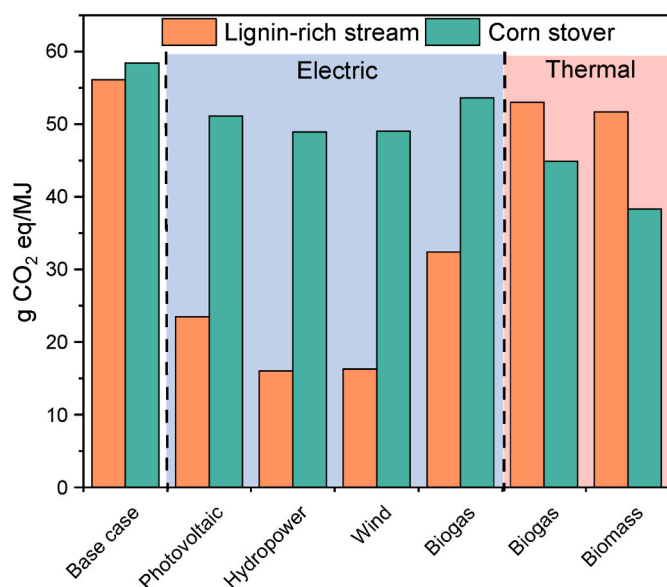

Fig. 5. Influence of electricity and thermal energy source on the GWP of the HTL-APR biorefinery for the two investigated scenarios.

when fossil thermal energy is substituted using direct biomass combustion to produce the necessary heat, followed by thermal valorization of biogas (23%). In these cases, the environmental burden of the LRS-case decreases only slightly (6–8%) because of its lower thermal energy demand.

### 3.3.3. Hydrogen source

In this paragraph, the comparison in terms of GWP of different hydrogen sources is presented and the results are summarized in Fig. 6. The base case for LRS and CS is reported in Fig. 6A and B, respectively.

In Fig. 6C, the substitution of electrolysis by steam reforming was hypothesized to provide the make-up hydrogen necessary for the LRS scenario. This option reduces the environmental impact by 33% (37 g CO<sub>2</sub> eq/MJ) due to the lower GHG emissions of such technology (11 g CO<sub>2</sub> eq/g H<sub>2</sub> vs 26 g CO<sub>2</sub> eq/g H<sub>2</sub> from electrolyzer) [53]. In fact, electrolyzer can be a greener option than conventional steam reforming to provide hydrogen only if the source of electricity is renewable.

If electrolysis is employed to provide the entire hydrogen requirement of the upgrading step and no APR section is assumed (Fig. 6D), the GWP decreases by 7% in the LRS-case (52 g CO<sub>2</sub> eq/MJ) and increases by 17% in the CS-case (68 g CO<sub>2</sub> eq/MJ). Fig. 5E shows the case in which steam reforming is used for providing all the hydrogen. This option would decrease the LRS base case by 48% (29 g CO<sub>2</sub> eq/MJ) and the CS

base case by 12% (51 g CO<sub>2</sub> eq/MJ). These differences can be traced back to the impact of APR per amount of hydrogen produced: 41 g CO<sub>2</sub> eq/g H<sub>2</sub> for LRS and 16 g CO<sub>2</sub> eq/g H<sub>2</sub> for CS (the method for assessing the APR-related GWP is reported in the Supplementary Information).

Overall, the implementation of APR allows to reduce the GWP of the CS-case with respect to electrolysis, while it is higher in the other scenarios. However, it must be noted that, unlikely steam reforming, APR of HTL wastewater complies with the development of a circular economy, which can contribute to the societal pursuit of energy independence. Furthermore, APR does not suffer from the intrinsic fluctuations related to the use of renewable energies devoted to water electrolysis.

The analysis conducted here clearly suggests that the APR environmental footprint is highly dependent on the impact of platinum, as 83% of the GWP of APR is related to the platinum-based catalyst. For this reason, it is stressed the necessity of developing effective non-noble metals catalysts for APR implementation on a long-term scale. Nevertheless, it should be cited that a conservative assumption was used here, i.e. that 72% of the platinum derived from new mining, while the remaining 28% was recovered through recycling techniques. However, since the spent catalysts would be returned to the producer and hence regenerated, the precious metal would be fully recovered, with a significant advantage on an environmental (and economic) perspective [54]. With the assumption of using 100% recycled platinum, the APR impact would decrease to 8.0 g CO<sub>2</sub> eq/g H<sub>2</sub> for LRS and 3.0 g CO<sub>2</sub> eq/g H<sub>2</sub> for CS, resulting lower than electrolysis and steam reforming in both cases.

## 3.4. Comparison with literature

### 3.4.1. Cradle-to-gate

As reported in many LCA works, a fair comparison with other results reported in the scientific literature is not an easy task due to the varying choices (e.g., about the functional unit, system boundaries or allocation) which can have a significant effect on the results. As suggested by Wiloso et al. for bioethanol production, clear and shared guidelines should be established to evaluate the environmental impact of biofuel production thanks to new technologies, and HTL can serve as an example [26].

Table 3 compares the environmental impact of 1 MJ of biofuel derived from an HTL-APR biorefinery with 1 MJ fuel from alternative biomass-based processes. We took into consideration a fast pyrolysis biofuel [55], bioethanol from fermentation, bio-oil from pyrolysis and jet fuel from gasification of corn stover [56]. The impacts related to the harvesting, transport and processing stages (i.e., excluding the use of the fuel) were derived, so that these figures could be considered coherent with the ones reported herein. Please note that with the fast pyrolysis plant, the GWP was not used as reference because it included the CO<sub>2</sub> uptake, making it not comparable with the present work.

In the fast pyrolysis case [55], the EP and AP were mainly attributed

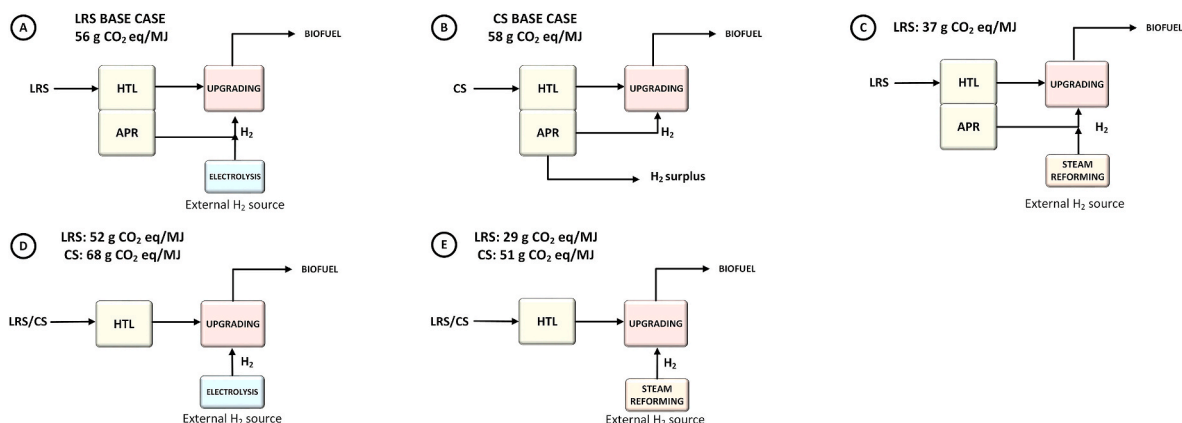

Fig. 6. Influence of hydrogen source on the GWP of the HTL-APR biorefinery for the two investigated scenarios.

**Table 3**

Comparison of impact categories of the HTL-APR biorefineries with alternative biofuels (1 MJ biofuel).

	HTL-APR (LRS)	HTL-APR(CS)	Fast pyrolysis (poplar) [55]	Pyrolysis (CS) [56]	Gasification-FT <sup>a</sup> (CS) [56]	Fermentation <sup>a</sup> (CS) [56]
GWP 100 year (g CO <sub>2</sub> eq)	56	58	- <sup>a</sup>	63	19	18
FDP (MJ eq)	0.64	0.83	0.81	–	–	–
AP (g SO <sub>2</sub> eq)	0.38	0.49	0.25	0.85	0.34	1.14
EP (mg PO <sub>4</sub> eq)	52	52	73	151	34	604

<sup>a</sup> Not taken into account because of different assumptions for CO<sub>2</sub> uptake and biogenic carbon emissions used.

to the pyrolysis plant, while the FDP was mostly accredited to the need of natural gas to produce the hydrogen for bio-oil upgrading. Electricity consumption was identified as the main source of AP. In Ref. [56], fossil-derived electricity contributed to GWP, AP and EP. The AP was found as one of the most critical categories because of NO<sub>x</sub> and SO<sub>2</sub> emissions during the combustion processes involving biomass (such as lignin by-product during fermentation and bio-char after pyrolysis). The higher GWP of pyrolysis compared to gasification and fermentation is attributed to the hydrogen requirement for the bio-oil upgrading which derived from natural gas steam reforming. The other impact categories are higher for fermentation due to the lower fuel yield and the consumption of chemicals during the operation. Unlike the present study, Sun et al. took into account the impact derived by the stover by allocating the impact of corn cultivation between corn and corn stover on an economic basis [56]; however, this choice can vary the results according to the market price of the waste, which is not yet stable [57].

The GWP of the pyrolysis is the highest among the biofuels evaluated and is slightly higher than GWP evaluated in the present study. However, CS-case and LRS-case had a higher GWP than gasification and fermentation. As reported before, this result is mainly ascribed to the impact related to the need of electricity for H<sub>2</sub> production (LRS) and external heating (CS). By changing the electricity and heat sources allowed to reduce the GWP for both cases and to be more comparable with other biofuels. The eutrophication potential for both cases is lower than for any other biofuel, with exception of gasification, while the acidification potential is within the range of other biofuels. Looking at FDP, the value obtained with the CS-case is slightly higher compared with the fast pyrolysis of poplar, while the LRS-case is significantly lower. The main contributors to the FDPs in this work are electrolysis and thermal demand, while the electricity used in the pyrolysis step is mainly for drying the biomass.

### 3.4.2. Well-to-wheels

Finally, it is necessary to compare the GWP with an equivalent fossil fuel. In this case, it is generally recommended to use a “well-to-wheels” system boundary, so that the growth and utilization stages (i.e. fuel combustion in the engine) are included [55]. To evaluate the well-to-wheels GWP, the GWP deriving from the biofuel usage must be added, as well as transport to the fuel station. The total GHG emissions due to combustion phase are evaluated by referring not only to CO<sub>2</sub> exhaust emissions, but also by taking into account the emissions of methane (CH<sub>4</sub>) and nitrous oxide (N<sub>2</sub>O) [58]. However, the CO<sub>2</sub> produced during the use of the biofuel can be considered zero, being biogenic CO<sub>2</sub>. Thus, the impact of combustion in terms of CO<sub>2</sub> eq can be calculated as the sums of CH<sub>4</sub> and N<sub>2</sub>O, resulting in 0.98 g CO<sub>2</sub> eq/MJ [58]. With regard to the transport of the biofuel, a distance to be covered by truck of 15 km was assumed [59], and the resulting impact was limited (0.03 g CO<sub>2</sub> eq/MJ). The well-to-wheels GWP hence results equal to 57.1 and 59.4 g CO<sub>2</sub> eq/MJ for LRS and CS, respectively.

In Fig. 7 the well-to-wheels GWP for the previously presented biofuels is reported, as well as the reference value for fossil diesel (89.1 g CO<sub>2</sub> eq/MJ) [57]. The GWP of the HTL-APR plant results higher than those of fermentation and gasification but lower than that of pyrolysis, even when comparing them within a well-to-wheels boundary system. Compared to fossil diesel, the HTL-APR technology shows better performances (−37%), highlighting the environmental benefit of such

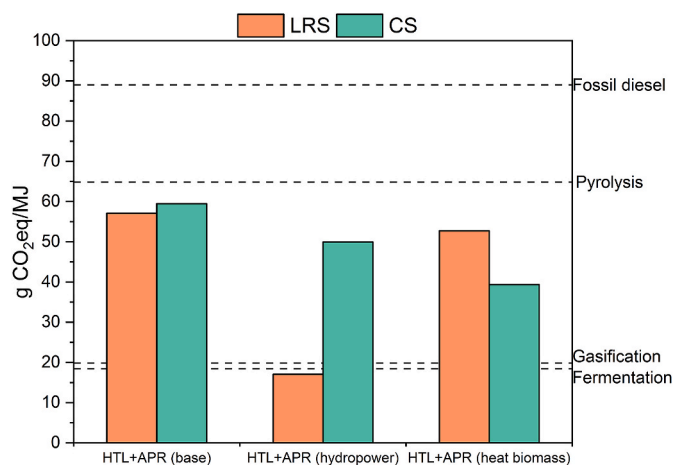

**Fig. 7.** Comparison of global warming potential well-to-wheels between HTL-APR and alternative technologies (1 MJ biofuel).

integration. A further GWP reduction compared to fossil diesel can be obtained if a change in the electricity or in the heat source is adopted, as reported in paragraph 3.3.2. In fact, using electricity from hydropower allowed a reduction of 80% for the LRS-case, while a reduction of 55% is reached for the CS-case with thermal power from biomass. In this way, this technology could achieve the 65% reduction in greenhouse gases with biofuels compared with fossil equivalents indicated by the Renewable Energy Directive (RED II).

## 4. Conclusions

In this work, a life cycle assessment of a biorefinery integrating hydrothermal liquefaction and aqueous phase reforming for the production of advanced biofuels was performed for the first time. These two technologies were coupled to increase the carbon conversion efficiency and limit dependence on fossil-based hydrogen. Two cases were evaluated based on two different lignocellulosic feedstocks: corn stover and lignin-rich stream from a 2nd generation bioethanol plant.

The global warming potential was similar between the two cases (approximately 57 CO<sub>2</sub> eq/MJ), but the sources of emissions were different. Our results emphasize the dramatic impact of electrolysis, and hence electricity, in the LRS-case, which consequently outlines the challenge of low-carbon electricity demand and the advantage of APR implementation. Furthermore, the environmental burden resulting from platinum use (second highest contribution in the CS-case) highlights that noble metal-based catalysts should be avoided if a more sustainable process is desired, and hence further research should be devoted to the development of active, selective and stable noble metal-free (e.g., based on transitional metals) catalysts. With regard to the other impact categories investigated, the corn-stover case had a 28% higher potential for acidification and fossil depletion, mainly driven by electricity, thermal energy and catalyst. The analysis of uncertainties showed higher variation for LRS with regard to GWP, and for CS with regard to AP. The sensitivity analysis conducted to evaluate the influence of different parameters showed that the use of renewable electricity (wind and hydro)

reduced the GWP of the LRS-case by 71%, while renewable thermal energy decreased the GWP of the CS-case by 34%. Furthermore, the influence of the hydrogen source pointed out that aqueous phase reforming is environmentally competitive, as it has lower GWP compared to electrolysis.

Despite the complexity of comparing LCA results found in the literature, due to different methodological choices and sources of uncertainties, it must be highlighted that the biofuel derived from an HTL-APR biorefinery has a lower environmental burden than pyrolysis already in the base case scenario (electricity derived from actual grid mix), while it is lower than gasification and fermentation only using a decarbonized electricity in the LRS-case. In conclusion, this work presented an environmentally sustainable alternative to fossil diesel by coupling HTL and APR in a biofuel-oriented biorefinery, highlighting synergies (such as APR of HTL-wastewater) and bottlenecks (such as the fossil share of electricity and the use of noble metal catalysts) that must be overcome to foster the decarbonization of the transport sector.

### Declaration of competing interest

The authors declare that they have no known competing financial interests or personal relationships that could have appeared to influence the work reported in this paper.

### Data availability

Data will be made available on request.

### Acknowledgment

The project leading to this research has received funding from the European Union's Horizon 2020 research and innovation program under grant agreement N° 764675.

### Appendix A. Supplementary data

Supplementary data to this article can be found online at <https://doi.org/10.1016/j.renene.2023.02.011>.

### References

- [1] D. Chiamonti, G. Talluri, N. Scarlat, M. Prussi, The challenge of forecasting the role of biofuel in EU transport decarbonisation at 2050: a meta-analysis review of published scenarios, *Renew. Sustain. Energy Rev.* 139 (2021), 110715, <https://doi.org/10.1016/j.rser.2021.110715>.
- [2] J. Lu, J. Watson, Z. Liu, Y. Wu, Elemental migration and transformation during hydrothermal liquefaction of biomass, *J. Hazard Mater.* 423 (2022), 126961, <https://doi.org/10.1016/j.jhazmat.2021.126961>.
- [3] E. Panisko, T. Wietsma, T. Lemmon, K. Albrecht, D. Howe, Characterization of the aqueous fractions from hydrotreatment and hydrothermal liquefaction of lignocellulosic feedstocks, *Biomass Bioenergy* 74 (2015) 162–171, <https://doi.org/10.1016/j.biombioe.2015.01.011>.
- [4] R.B. Madsen, P. Biller, M.M. Jensen, J. Becker, B.B. Iversen, M. Glasius, Predicting the chemical composition of aqueous phase from hydrothermal liquefaction of model compounds and biomasses, *Energy Fuel.* 30 (2016) 10470–10483, <https://doi.org/10.1021/acs.energyfuels.6b02007>.
- [5] Y. Zhu, M.J. Bidy, S.B. Jones, D.C. Elliott, A.J. Schmidt, Techno-economic analysis of liquid fuel production from woody biomass via hydrothermal liquefaction (HTL) and upgrading, *Appl. Energy* 129 (2014) 384–394, <https://doi.org/10.1016/j.apenergy.2014.03.053>.
- [6] J. Watson, T. Wang, B. Si, W.T. Chen, A. Aierzhati, Y. Zhang, Valorization of hydrothermal liquefaction aqueous phase: pathways towards commercial viability, *Prog. Energy Combust. Sci.* 77 (2020), 100819, <https://doi.org/10.1016/j.pecs.2019.100819>.
- [7] Y. Liang, A critical review of challenges faced by converting food waste to bioenergy through anaerobic digestion and hydrothermal liquefaction, *Waste and Biomass Valorization* (2021), <https://doi.org/10.1007/s12649-021-01540-9>.
- [8] L. Leng, W. Zhang, S. Leng, J. Chen, L. Yang, H. Li, et al., Bioenergy recovery from wastewater produced by hydrothermal processing biomass: progress, challenges, and opportunities, *Sci. Total Environ.* 748 (2020), 142383, <https://doi.org/10.1016/j.scitotenv.2020.142383>.
- [9] P. Westermann, B. Jørgensen, L. Lange, B.K. Ahring, C.H. Christensen, Maximizing renewable hydrogen production from biomass in a bio/catalytic refinery, *Int. J. Hydrogen Energy* 32 (2007) 4135–4141, <https://doi.org/10.1016/j.ijhydene.2007.06.018>.
- [10] R.D. Cortright, R.R. Davda, J.A. Dumesic, Hydrogen from catalytic reforming of biomass-derived hydrocarbons in liquid water, *Nature* 418 (2002) 964–967, <https://doi.org/10.1038/nature01009>.
- [11] R.R. Davda, J.W. Shabaker, G.W. Huber, R.D. Cortright, J.A. Dumesic, A review of catalytic issues and process conditions for renewable hydrogen and alkanes by aqueous-phase reforming of oxygenated hydrocarbons over supported metal catalysts, *Appl. Catal. B Environ.* 56 (2005) 171–186, <https://doi.org/10.1016/j.apcatb.2004.04.027>.
- [12] I. Coronado, M. Stekrova, M. Reinikainen, P. Simell, L. Lefferts, J. Lehtonen, A review of catalytic aqueous-phase reforming of oxygenated hydrocarbons derived from biorefinery water fractions, *Int. J. Hydrogen Energy* 41 (2016) 11003–11032, <https://doi.org/10.1016/j.ijhydene.2016.05.032>.
- [13] G. Zoppi, G. Pipitone, R. Pirone, S. Bensaid, Aqueous phase reforming process for the valorization of wastewater streams: application to different industrial scenarios, *Catal. Today* 387 (2022) 224–236, <https://doi.org/10.1016/j.cattod.2021.06.002>.
- [14] A. Swetha, S. Shrivigneshwar, K. Panchamoorthy, R. Sivaramkrishnan, R. Shanmuganathan, J. Arun, Review on hydrothermal liquefaction aqueous phase as a valuable resource for biofuels, bio-hydrogen and valuable bio-chemicals recovery, *Chemosphere* 283 (2021), 131248, <https://doi.org/10.1016/j.chemosphere.2021.131248>.
- [15] P. SundarRajan, K.P. Gopinath, J. Arun, K. GracePavithra, A. Adithya Joseph, S. Manasa, Insights into valuing the aqueous phase derived from hydrothermal liquefaction, *Renew. Sustain. Energy Rev.* 144 (2021), 111019, <https://doi.org/10.1016/j.rser.2021.111019>.
- [16] D.V. Cabrera, R.A. Labatut, Outlook and challenges for recovering energy and water from complex organic waste using hydrothermal liquefaction, *Sustain. Energy Fuels* 5 (2021) 2201–2227, <https://doi.org/10.1039/d0se01857k>.
- [17] G. Zoppi, G. Pipitone, C. Galletti, A.M. Rizzo, D. Chiamonti, R. Pirone, et al., Aqueous phase reforming of lignin-rich hydrothermal liquefaction by-products: a study on catalyst deactivation, *Catal. Today* 365 (2021) 206–213, <https://doi.org/10.1016/j.cattod.2020.08.013>.
- [18] G. Pipitone, G. Zoppi, S. Bocchini, A.M. Rizzo, D. Chiamonti, R. Pirone, et al., Aqueous phase reforming of the residual waters derived from lignin-rich hydrothermal liquefaction: investigation of representative organic compounds and actual biorefinery streams, *Catal. Today* 345 (2020) 237–250, <https://doi.org/10.1016/j.cattod.2019.09.040>.
- [19] A. Di Fraia, E. Miliotti, A.M. Rizzo, G. Zoppi, G. Pipitone, R. Pirone, et al., Coupling hydrothermal liquefaction and aqueous phase reforming for integrated production of biocrude and renewable H<sub>2</sub>, *AIChE J.* (2022) 1, <https://doi.org/10.1002/aic.17652>, –14.
- [20] D.C. Elliott, T.R. Hart, A.J. Schmidt, G.G. Neuenschwander, L.J. Rotness, M. V. Olarte, et al., Process development for hydrothermal liquefaction of algae feedstocks in a continuous-flow reactor, *Algal Res.* 2 (2013) 445–454, <https://doi.org/10.1016/j.algal.2013.08.005>.
- [21] Edoardo T, Zoppi G, Pipitone G, Miliotti E, Di Fraia A, Rizzo AM, et al. Conceptual design and techno-economic assessment of coupled hydrothermal liquefaction and aqueous phase reforming of lignocellulosic residues. *J. Environ.Chem. Eng.* n.d. [https://doi.org/\(Under review\)](https://doi.org/(Under review)).
- [22] Bs En Iso, +A1:2020 Environmental Management - Life Cycle Assessment - Principles and Framework, 14040, 2006 (n.d).
- [23] Bs En Iso, + A1:2018 + A2:2020 Environmental Management - Life Cycle Assessment - Requirements and Guidelines, 14044, 2006 (n.d).
- [24] European Commission-Joint Research Center, ILCD Handbook: General Guide for Life Cycle Assessment - Detailed Guidance, 2010, <https://doi.org/10.2788/38479>.
- [25] Ec-Jrc, Product Environmental Footprint (PEF) Guide, European Commission Jt Res Cent, 2012, p. 154.
- [26] H.M. Summers, R.N. Ledbetter, A.T. McCurdy, M.R. Morgan, L.C. Seefeldt, U. Jena, et al., Techno-economic feasibility and life cycle assessment of dairy effluent to renewable diesel via hydrothermal liquefaction, *Bioresour. Technol.* 196 (2015) 431–440, <https://doi.org/10.1016/j.biortech.2015.07.077>.
- [27] M.O.P. Fortier, G.W. Roberts, S.M. Stagg-Williams, B.S.M. Sturm, Life cycle assessment of bio-jet fuel from hydrothermal liquefaction of microalgae, *Appl. Energy* 122 (2014) 73–82, <https://doi.org/10.1016/j.apenergy.2014.01.077>.
- [28] Y.F. Khalil, Simulation-based environmental-impact assessment of glycerol-to-hydrogen conversion technologies, *Clean Energy* 5 (2021) 387–402, <https://doi.org/10.1093/ce/zkab018>.
- [29] F.J. Gutiérrez Ortiz, B. Alonso-Fariñas, F.J. Campanario, A. Kruse, Life cycle assessment of the Fischer-Tropsch biofuels production by supercritical water reforming of the bio-oil aqueous phase, *Energy* 210 (2020), <https://doi.org/10.1016/j.energy.2020.118648>.
- [30] European Commission, Directive 2009-28-EC on the Promotion of the Use of Energy from Renewable Sources, 2014. Brussels.
- [31] E.I. Wiloso, R. Heijungs, G.R. De Snoo, LCA of second generation bioethanol: a review and some issues to be resolved for good LCA practice, *Renew. Sustain. Energy Rev.* 16 (2012) 5295–5308, <https://doi.org/10.1016/j.rser.2012.04.035>.
- [32] Q. Dang, C. Yu, Z. Luo, Environmental life cycle assessment of bio-fuel production via fast pyrolysis of corn stover and hydroprocessing, *Fuel* 131 (2014) 36–42, <https://doi.org/10.1016/j.fuel.2014.04.029>.
- [33] M.K. Lam, K.T. Lee, A. Rahmanmohamed, Life cycle assessment for the production of biodiesel: a case study in Malaysia for palm oil versus jatropha oil, *Biofuels, Bioprod. Biorefining* 3 (2009), <https://doi.org/10.1002/bbb.182>.

- [34] K.F. Yee, K.T. Tan, A.Z. Abdullah, K.T. Lee, Life cycle assessment of palm biodiesel: revealing facts and benefits for sustainability, *Appl. Energy* 86 (2009) S189–S196, <https://doi.org/10.1016/j.apenergy.2009.04.014>.
- [35] M.M. Czymrek-Delêtre, B.M. Smyth, J.D. Murphy, Beyond carbon and energy: the challenge in setting guidelines for life cycle assessment of biofuel systems, *Renew. Energy* 105 (2017) 436–448, <https://doi.org/10.1016/j.renene.2016.11.043>.
- [36] F. Keller, R.P. Lee, B. Meyer, Life cycle assessment of global warming potential, resource depletion and acidification potential of fossil, renewable and secondary feedstock for olefin production in Germany, *J. Clean. Prod.* 250 (2020), 119484, <https://doi.org/10.1016/j.jclepro.2019.119484>.
- [37] R.K. Sinnott, J.M. Coulson, J.F. Richardson, *Chem. Eng. ume 6 – Design* (1983).
- [38] Net electricity generation, EU27, 2019 n.d., 2019 (%25\_based\_on\_GWh).png, [https://ec.europa.eu/eurostat/statistics-explained/index.php?title=File:Net\\_electricity\\_generation\\_EU27](https://ec.europa.eu/eurostat/statistics-explained/index.php?title=File:Net_electricity_generation_EU27). (Accessed 1 May 2022). accessed.
- [39] M. Sánchez, E. Amores, D. Abad, L. Rodríguez, C. Clemente-Jul, Aspen Plus model of an alkaline electrolysis system for hydrogen production, *Int. J. Hydrogen Energy* 45 (2020) 3916–3929, <https://doi.org/10.1016/j.ijhydene.2019.12.027>.
- [40] D.A. Sladkovskiy, L.I. Godina, K.V. Semikin, E.V. Sladkovskaya, D.A. Smirnova, D. Y. Murzin, Process design and techno-economical analysis of hydrogen production by aqueous phase reforming of sorbitol, *Chem. Eng. Res. Des.* 134 (2018) 104–116, <https://doi.org/10.1016/j.cherd.2018.03.041>.
- [41] International Platinum Group Metals Association, *The Life Cycle Assessment of Platinum Group Metals*, 2017.
- [42] E. Van Der Voet, R.J. Lifset, L. Luo, Life-cycle assessment of biofuels, convergence and divergence, *Biofuels* 1 (2010) 435–449, <https://doi.org/10.4155/bfs.10.19>.
- [43] Ó. Ögmundarson, S. Sukumara, A. Laurent, P. Fantke, Environmental hotspots of lactic acid production systems, *GCB Bioenergy* 12 (2020) 19–38, <https://doi.org/10.1111/gcbb.12652>.
- [44] L.J. Snowden-Swan, K.A. Spies, G.J. Lee, Y. Zhu, Life cycle greenhouse gas emissions analysis of catalysts for hydrotreating of fast pyrolysis bio-oil, *Biomass Bioenergy* 86 (2016) 136–145, <https://doi.org/10.1016/j.biombioe.2016.01.019>.
- [45] L. Duclos, M. Lupsea, G. Mandil, L. Svecova, P.X. Thivel, V. Laforest, Environmental assessment of proton exchange membrane fuel cell platinum catalyst recycling, *J. Clean. Prod.* 142 (2017) 2618–2628, <https://doi.org/10.1016/j.jclepro.2016.10.197>.
- [46] C. Acar, I. Dincer, Hydrogen Production, vols. 3–5, 2018, <https://doi.org/10.1016/B978-0-12-809597-3.00304-7>.
- [47] A.C. Hetherington, A.L. Borrión, O.G. Griffiths, M.C. McManus, Use of LCA as a development tool within early research: challenges and issues across different sectors, *Int. J. Life Cycle Assess.* 19 (2014) 130–143, <https://doi.org/10.1007/s11367-013-0627-8>.
- [48] G. Finnveden, M.Z. Hauschild, T. Ekvall, J. Guinée, R. Heijungs, S. Hellweg, et al., Recent developments in life cycle assessment, *J. Environ. Manag.* 91 (2009) 1–21, <https://doi.org/10.1016/j.jenvman.2009.06.018>.
- [49] Z. Barahmand, M.S. Eikeland, Life cycle assessment under uncertainty: a scoping review, *World* 3 (2022) 692–717, <https://doi.org/10.3390/world3030039>.
- [50] P.T. Benavides, D.C. Cronauer, F. Adom, Z. Wang, J.B. Dunn, The influence of catalysts on biofuel life cycle analysis (LCA), *Sustain. Mater. Technol.* 11 (2017) 53–59, <https://doi.org/10.1016/j.susmat.2017.01.002>.
- [51] W. Liu, Z. Zhang, X. Xie, Z. Yu, K. Von Gadow, J. Xu, et al., Analysis of the global warming potential of biogenic CO<sub>2</sub> emission in life cycle assessments, *Sci. Rep.* 7 (2017) 1–8, <https://doi.org/10.1038/srep39857>.
- [52] R. Bhandari, C.A. Trudewind, P. Zapp, Life cycle assessment of hydrogen production via electrolysis - a review, *J. Clean. Prod.* 85 (2014) 151–163, <https://doi.org/10.1016/j.jclepro.2013.07.048>.
- [53] Bhandari R, Trudewind CA, Zap P. Life Cycle Assessment of Hydrogen Production Methods-A Review Contribution to ElyGrid Project. n.d.
- [54] S. Gunukula, R.P. Anex, Techno-economic analysis of multiple bio-based routes to adipic acid, *Biofuels, Bioprod. Biorefining* 11 (2017), <https://doi.org/10.1002/bbb.1797>.
- [55] J.F. Peters, D. Iribarren, J. Dufour, Simulation and life cycle assessment of biofuel production via fast pyrolysis and hydrougrading, *Fuel* 139 (2015) 441–456, <https://doi.org/10.1016/j.fuel.2014.09.014>.
- [56] H. Sun, Z. Luo, S. Li, S. Xue, Q. Zhou, T. Wei, et al., Comparative life cycle assessment (LCA) of biofuel production via corn stover: fermentation to ethanol, pyrolysis to bio-oil, and gasification to jet fuel, *Biomass Convers. Biorefinery* (2021), <https://doi.org/10.1007/s13399-021-02054-z>.
- [57] R. Edwards, V. Mahieu, J.C. Griesemann, J.F. Larivé, D.J. Rickeard, Well-to-Wheels Analysis of Future Automotive Fuels and Power Trains in the European Context - Report, 2004, <https://doi.org/10.4271/2004-01-1924>. Version 3c.
- [58] A. Huss, P.E.C. Weingerl, Tank-to-Wheel Report V5: Passenger Cars, 2020, <https://doi.org/10.2760/557004>. Luxembourg.
- [59] G.A. Tsalidis, F. El Discha, G. Korevaar, W. Haije, W. de Jong, J. Kiel, An LCA-based evaluation of biomass to transportation fuel production and utilization pathways in a large port's context, *Int. J. Energy Environ. Eng.* 8 (2017) 175–187, <https://doi.org/10.1007/s40095-017-0242-8>.