

Evaluations on hydrogen fuel cells as a source of energy
for specific operations category civil RPAS systems

Original

Evaluations on hydrogen fuel cells as a source of energy

for specific operations category civil RPAS systems / Bonfante, Federica; Dalla Vedova, M. D. L.; Maggiore, P.; Battipede, M.; Grimaccia, F.. - ELETTRONICO. - International Journal of Computers:(2017), pp. 233-238. (4th International Conference on AERONAUTICAL and MECHANICAL ENGINEERING (AEME '17) Rome, Italy December 15-17, 2017 ROMA 15-17 DICEMBRE 2017).

Availability:

This version is available at: 11583/2713384 since: 2018-09-20T01:35:53Z

Publisher:

IARAS

Published

DOI:

Terms of use:

This article is made available under terms and conditions as specified in the corresponding bibliographic description in the repository

Publisher copyright

(Article begins on next page)

Proceedings of the V Ibero-American

Congress of Smart Cities

ICSC-CITIES 2022

Cuenca, Ecuador, November 28th to 30th
Hosted and sponsored by Universidad de Cuenca

Editors:

Pedro Moreno-Bernal
Luis Hernández-Callejo
Sergio Nesmachnow
Diego Rossit
Danny Ochoa-Correa



UCUENCA



CIUDADES INTELIGENTES TOTALMENTE INTEGRALES, EFICIENTES Y SOSTENIBLES

UVa



UNIVERSIDAD
DE LA REPÚBLICA
URUGUAY



UNIVERSIDAD AUTÓNOMA DEL
ESTADO DE MORELOS



Elaborated by the Organizing Committee of the V Ibero-American Congress of Smart Cities (ICSC-CITIES 2022).

Disclaimer: The information in this book is true and complete to the best of the editor's knowledge. All recommendations are made without a guarantee on the part of the editors. The editors disclaim any liability in connection with the use of this information.

Editors: **Pedro Moreno-Bernal, Luis Hernández-Callejo, Sergio Nesmachnow, Diego Rossit and Danny Ochoa-Correa.**

How to cite this book: Moreno-Bernal, P., Hernández-Callejo, L., Nesmachnow, S., Rossit, D. and Ochoa-Correa, D. (Eds.). (2022). Proceedings of the V Ibero-American Congress of Smart Cities. CITIES.

Cover: Centro Editorial UCuenca Press / Geovanny Gavilanes Pando

ISBN: **978-9942-44-109-6**



This work is licensed under a Creative Commons Attribution 4.0 International License.

Sustainable House Manufacturing for Smart Matching Cities

Paolo Piantanida¹, Claudia Pilar², Valentina Villa¹, Antonio Vottari¹

¹ DISEG-Politecnico di Torino, 10129 Torino, Italy

² FAU-Universidad Nacional del Nordeste, 3500 Resistencia, Argentina
paolo.piantanida@polito.it

Abstract. In bottom-up approach to the smart city, the construction of the house and its related land consumption is the fundamental cell for governing urban development and its sustainable relationship with society and the rural area. Given the situation in northern Argentina, the research outlines a construction system based on the sustainable wood supply chain, with industrialized production of wood wafer panels and the proposal of a deconstructible house whose elements can be transported by truck. Sustainability of the building system is achieved through the use of wood from rotational forests and the proposed re-purposing of river and rail transport, while building sustainability is pursued through the integrated use of photovoltaics, heat pump, rainwater and surface geothermal energy. The designed dwelling envelope results B rated, according to the IRAM 11605 Argentine standard and the “Minimum Quality Standards for Social Housing”.

Keywords: prefabricated building wood components, energy efficiency, rain-water usage.

1 Introduction

«A smart city should above all be a human city. [...] Today, digital platforms are key components of all these urban systems but I don't believe they are the real answer. What would help is to imagine the city differently in a more radical way» stated Carlos Moreno in an interview in 2019 [1]. If we consider how the urban metabolism is affected by supply and waste of construction materials before any building goes into service, we can argue the sustainability impact of construction phase is not negligible, even if the present standard and law context does not seem to care a lot, while building energy efficiency is much more under (sometimes strict) regulations.

In this context, the Authors investigated in the last years how to improve the city metabolism and sustainability by a bottom-up approach, that is, working on the basic bit the urban fabric is made of: housing.

First, smart buildings must be brilliantly managed and produced in a sustainable way. Second, a really smart location of smart buildings (and homes) is a matter of urban planning, of a radical change in the conception of the city. Third, collaborative networking, IoT, and big data management etc. are critical, but they are the rails to guide

change, not the engine and the fuel for it. Confident in these three criteria, the research team began working on the first assumption.

Sustainable houses should adapt to the local availability of energy, e.g., solar energy and rainwater, by integrating into the area network: reducing energy demand for HVAC systems and managing rainwater could be a brilliant way to physically integrate the building into the urban organism; furthermore, learning from nature, a sustainable housing system should be located where humans carry out their main activities (unlike human behavior, it is not common to travel far to work in nature) and thus, in principle, houses could be moved according to the supply of work. In this way, clogged streets, traffic jams, and peak hours of public transportation could be relieved, the city would become more human-scale, and, ideally, people would choose to travel primarily for leisure. Moreover, relocation for work would not necessarily imply abandoning an empty building “shell” to seek or build another one elsewhere. The result would be a dynamic city not only in the metabolism of energy and networked resources, but also in the texture of the building fabric.

This paper presents a proposal for a sustainable housing construction/deconstruction system suitable for the forest resources of Argentina and Latin America. The system is designed to meet the energy integration needs mentioned above, and its production is aimed at fostering the demand for local labor force, avoiding its relocation.

Based on the forestry situation in Argentina, we propose a possible way to locally industrialize the prefabrication of the main components for such type of building system, comparing the expected performance with the requirements of Argentine social housing legislation and some case studies of prefabricated housing.

2 Argentina’s forestry and wood supply chain current situation

Argentina has 33 million hectares of native forests and about 1 200 000 hectares of production forests (the latter with a growth of 40 000 hectares per year) and it’s one of the most productive countries in Latin America in the forestry sector.

Wood production yearly rates of Argentine forests, mainly pine and eucalyptus, range between 35 m³ and 45 m³ per hectare and are about 6-10 times higher than production rates recorded in European and North American forests [2]. This is made possible by favorable climatic conditions and soil quality enjoyed by Argentina’s forests (which allow above-average growth rates), most of which belong to the green lung of Gran Chaco in *Nordeste Argentino* (NEA), which is the second largest tropical forest in Latin America after Amazon rainforest. According to *Ministerio de Agroindustria* data released in 2015, 85% of country’s total wood production is concentrated precisely in *Nordeste*, whose main provinces are Misiones, Corrientes and Entre Ríos.

Despite the enormous potential related to continuous availability of raw material, Argentine wood supply chain has several problems basically related to infrastructural deficiencies and high costs for logistics (timber storage and transportation). This is caused by the large distance between NEA forests and main commercial ports in the central provinces of Santa Fe, Córdoba, and Buenos Aires. At present, connection between production centers and ports (foreign market) or distribution centers (domestic

market) is only possible by tractor trailers that travel along existing road networks, resulting in poor sustainability and disadvantages in terms of time, cost, personnel employment for transportation, and increased pollution.

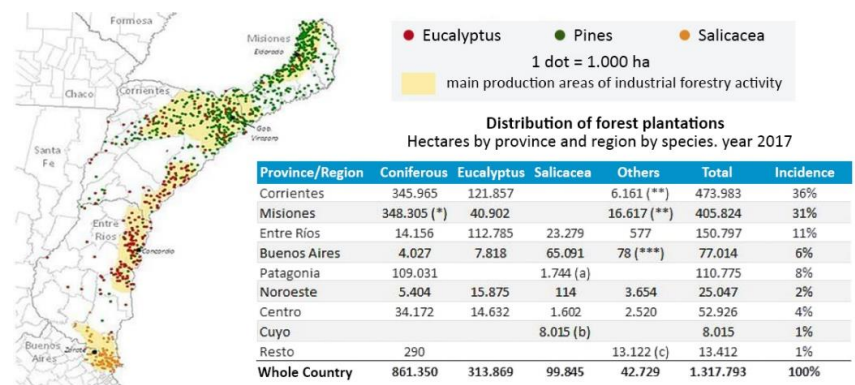

Fig. 1. Map of production forests in *Nordeste Argentino* (NEA) and Table of hectare distribution of production forests broken down by provinces. [3]

A significant abatement of transportation charges and environmental footprint could result from the use of alternative infrastructure or the smart rehabilitation of decommissioned ones.

In the first case, thanks to the presence of Paraná and Uruguay rivers (which connect the NEA with areas where actually ports and distribution centers take place), river transport could be a promising alternative, so much that Argentine government already attempted to encourage the birth of this network in the 1990s, through the construction of some river ports. However, the lack of agreements with neighboring countries, which share the river basin, has not so far allowed for a consolidation of this transport network.

In the second case, an important alternative to the road network could come from the use of the current rail network, with an upgrading of *Nordeste Argentino* local network and its connections to central areas. Argentina’s current forestry situation is thus divided between infrastructural deficiencies and new prospects for more economically and environmentally sustainable models.

3 A more sustainable wood supply chain

The housing needs due also to manpower relocation and the forestry situation previously described suggest a systemic approach to the whole wood supply chain, in order to better express social, economic benefits and sustainable development.

The housing issue can be addressed not only by improving subsidized housing, but also by increasing the income of those who, today, find it difficult to access the housing resource: both of these objectives can favorably dovetail with the development of forest

resource, providing that its use is tied to rotational plantations in order to reverse the current deforestation trend.

A sustainable forest management in the NEA would complement the traditional agricultural economy, also by involving the natives in occupations and incomes that would result from a responsible management of rotational plantations, without imposing extraneous working models to local cultures. There are many abandoned industrial areas in Chaco, usually relics related to industrial exploitation of agricultural resources, e.g., the production of various seed oils for food use. These areas are often close to river routes or railroad networks and their redevelopment could allow the settlement of new activities related to timber processing from rotational forests wood into building components, in order to increase employment and local professional qualifications in a social process that is aimed at the placement of both young recent graduates and skilled unemployed people in the world of work.

Abandoned industrial sites cover more than 80 hectares of land in Chaco area and they include some large warehouses used until the second half of the 20th century: most of those are in disrepair, but about one-third are reusable through modest rehabilitation works (mainly roof and facility renovation). Road, rail and energy network are still potentially efficient.

The historical industrial heritage reuse and recovery is a proactive activity that tends to enhance the history of a territorial area: the feasibility of industrial redevelopment and reactivation is based both on the advantage provided by reuse of existing facilities in term of environmental, social and economic sustainability, and also on new opportunities of education and training dissemination powered by the new industry demand. In contexts of relevant economic fragility, such as the city of Resistencia in Chaco, the synergy between education-training-cultivation-production-construction is a particularly essential condition for the feasibility and sustainability of this systemic approach.

The restart of Chaco industry is also a favorable condition for the enhancement of more sustainable transportation systems alternatives to road. The rail network was initially sized and articulated to serve factories that have now disappeared: for this reason, its reactivation and coordination with the rest of the Argentine rail system does not require large resources, but rather a new connected and smart management system (e.g., rail freight convoys with electric locomotives should travel only when the sun provides sufficient energy through photovoltaic farms: timber has no deadline and no hurry) and provides, on the other hand, an additional factor for the development of employment and social welfare. The river network can be managed almost in the same way.

Using alternative and more sustainable methods to transport building components constitutes an added value compared to the raw material alone, lowering the unit selling price thanks to a less impact handling charges and favoring the spread of the product. The latter, consisting of building envelope elements, has in turn the potential to be a driver of a wood construction market that, in Argentina, can still grow a great deal and will increasingly need skilled figures (from designers to assemblers). This will have a positive spin-off in local employment opportunities and in the quality of available housing. Not only jobs, then, but also increased income to facilitate access to housing and its increased quality, also far from urban areas, where the complexity of access routes may make transportation of prefabricated building components less immediate. The

systemic approach to the wood supply chain, moreover, has positive spillover effects on satellite activities: from service and network providers, to equipment maintainers, railroaders, seafarers, etc., which is a significant multiplier of investment, public or private, in this sector. However, this is limited by the low uptake of wood construction with industrialized components (e.g., panels), which today is still conditioned by certain regulatory preconceptions.

4 A look to the current social housing regulations in Argentina

Over the past two decades, Argentina has completed a series of regulatory efforts to improve habitability and thermo-hygrometric comfort of social housing, along with an increasing attention and care for environmental sustainability.

From 2000 to 2019 there have been a series of regulations with technical prescriptions to increase requirements for thermal quality, use of renewable energy, and procedures and technical specifications have been introduced for the evaluation, diagnosis and certification of constructions according to sustainability criteria established by Argentine legislation [4].

Secretaría de Vivienda del Ministerio de Infraestructura y Vivienda de la Nación, together with *Ministerio de Ambiente y Desarrollo Sustentable* y el *Ministerio de Energía* have produced in 2018 the “Handbook of Sustainable Building” [5]: this guide (regarding Site, Integral Design, Energy, Water, Urban Agriculture, Building, and Best Practices) proposes an assessment tool called “traffic light” which emphasizes for each topic the distinction of desirable versus undesirable variables and effects. The tool also incorporates the concepts of flexible and accessible design in addition to the need to carry forward building design by contemplating future plans for redevelopment, deconstruction and recycling.

Among the possible technological solutions for construction, one of the main aspects that limited (and partially still hinders) wood construction is the fact that it was considered by Argentine regulations to be an “unconventional” system. For this very reason, any use of it required the development of a “Certificate of Technical Aptitude” (CAT) to be submitted to the *Secretaría de Vivienda*, for which it was necessary to complete numerous tests, trials and produce a thorough technical report.

Since 2018, however, Resolution 3-E-2018 of the Ministry of Housing and Habitat [6] has finally recognized the wood frame construction system as “traditional”: thanks to this recognition, the wood house sector has benefited from a major regulatory update and a significant incentive that greatly favors this system over others. The growing awareness and concern for environmental issues, coupled with the abolition of CAT, have created favorable conditions for rethinking the wood supply chain in the construction industry, also in terms of sustainability and social spinoff.

Considering energy saving strategy, the “Minimum quality standards for Social housing” [7] stated the value of “K” (thermal transmittance) for the exterior wall and roof must be equal to or lower than the maximum established in Table 1 of IRAM 11605 standard (1996 edition) for level B, i.e., 0.6 to 1 W/m²K for walls and 0.52 to 0.83 W/m²K for roofs (depending on the local climate).

5 Housing sustainable rethinking

Some best practices on wood housing in Argentina can be traced among recent social housing developments.

In the city of Virasoro (province of Corrientes), 320 km far from the capital, 11 social housing units of 70 m² each were built in 2015: the prototype was designed by the Corrientes Housing Institute (INVICO) and consists of a one floor building with dining/living room, a kitchen, a bathroom, two bedrooms and two covered loggias (Fig. 2). This plan setting derives from the traditional local housing model. These houses were built with wood-frame technology and insulated infills, pitched roofing, interior sheathing of gypsum board, and exterior cladding of painted wood; windows and doors are made of aluminum frame. The constructions rest on a raised and ventilated basement in order to avoid contact between wooden elements and soil moisture. Each dwelling was built in 29 working days by four carpenters, an electrician and a plumber and 14.15 m³ of lumber was used [8].



Fig. 2. Floor plan, elevation and photographs of the construction phases of INVICO's *viviendas sociales* at the Virasoro locality. [© INVICO (drawings) and Erick Kennedy (photographs)]

Similarly, in Entre Ríos Province, twelve houses were built between 2014 and 2015 in the Chaco neighborhood of the city of Chajari, each one of 67 m². In 2016, eight more houses of 62 m² each were built in the La Florida neighborhood. Also in the province of Entre Ríos, in the city of Concordia, another 250 houses are being built in the Agua Patito neighborhood, in order to be able to relocate families who lived in the

flooded areas: these are 48 m² homes, each of which used 3.6 m³ of wood for the load-bearing structure in addition to 65 m² of facade cladding made of horizontal solid wood slats laid in “American style”, 170 m² of interior matchboarding, and 30 boards of 9 mm thick phenolic plywood.

6 Toward a prototype of a locally produced system for wooden houses

As anticipated in § 3, this research investigated the possibility of local production of sandwich panels, framed elements and complements to promote the integral use of wood resource and, at the same time, to improve local housing conditions, enhancing skills and availability of local workforce, as well as responding to the needs of Argentine housing emergency, especially in the North, also conditioned by the persistent difficulty in accessing housing credit [9].

Below are described the first results obtained in the design of the technological system, which is first and foremost oriented toward simplifying the manufacturing process, lowering construction and handling costs, and favoring simple and flexible floor plans.

This flexibility and simplicity appeared to be a necessary condition to allow the declination of the proposed model according to the various cultural, social and climatic instances that are a very true expression of the local tradition: in fact, the diffusion of a “new” building system cannot be associated with the imposition of a new way of living, but rather the system itself should be naturally metabolized by the socio-cultural context of reference, which can “appropriate” it in the ways and with respect to local customs. The sustainable city can be made of sustainable technology, but it can not be made of sustainable buildings that are empty and rejected.

For this reason, the example of conceptual application of the system is intentionally inspired by the traditional *vivienda rural* that is typical of the northern subtropical region of Argentina (fig. 4). The so-called *casa rural* was born in close contact with the territory and its climate, so much that home is a simple shelter from bad weather and only destined for basic functions such as sleeping, cooking, and even giving refuge to domestic animals. As a result, the *vivienda* has no definite boundaries, there is no clear or fixed separation between inside and outside, and it is not even possible to “crystallize” certain functions within it. The functional scheme is therefore an open and dynamic model always connected to the outdoor, both to extend the living function to the outside environment and to allow further additions through aggregation of the same model, which is developed on a single floor usually elevated above the ground in order to prevent possible river flooding. The *galería* is the recurring element: a central aggregative space, covered but not enclosed, in which all the social activities of daily life take place. On this *galería* insist the *habitación*, which consists of bedrooms, the only enclosed spaces of the dwelling. Technological and planimetric linearity together with the use of natural materials (mainly wood) allow the implementation of a series of bioclimatic principles to which these Argentine rural houses conform, achieving favorable interior microclimates thanks, for example, to natural ventilation and shading control

(think of the opposing openings of the central *galería*, or shading and evapotranspiration cooling given by dense surrounding vegetation). Two rural homes are illustrated in Fig. 3 [10, 11].

The proposed technological system is based on locally producible elements: 2 or 4 cm thick wood planks measuring 132×52 cm (and also 17 or 10 cm to allow better utilization of the log), while the processing waste is used to produce wood wool that can form thermal insulation of the infill and bracing panel.

Specifically, “wafer” panels are conceived with solid perimeter frames suitable for tongue-and-groove joining, consisting of boards 4 cm thick on the outside and 2 cm thick on the inside. The thickness of the gap is governed by the thickness of the frame, which can be 2, 4, or 6 cm. In the most thermally favorable case (6 cm cavity filled with wood wool), the resulting panel has a thickness of 12 cm and a thermal transmittance of less than $0.5 \text{ W/m}^2\text{K}$ (which meets the B level required by the “Minimum Quality Standards for Social Housing”) i.e., four times more favorable than the more usual hollow brick wall of similar thickness ($2 \text{ W/m}^2\text{K}$) compared to which it would also be much lighter (30 kg versus 60 kg for an equal area of hollow brick wall). Smaller panels have corresponding lower performance, lower mass and lower manufacturing cost.

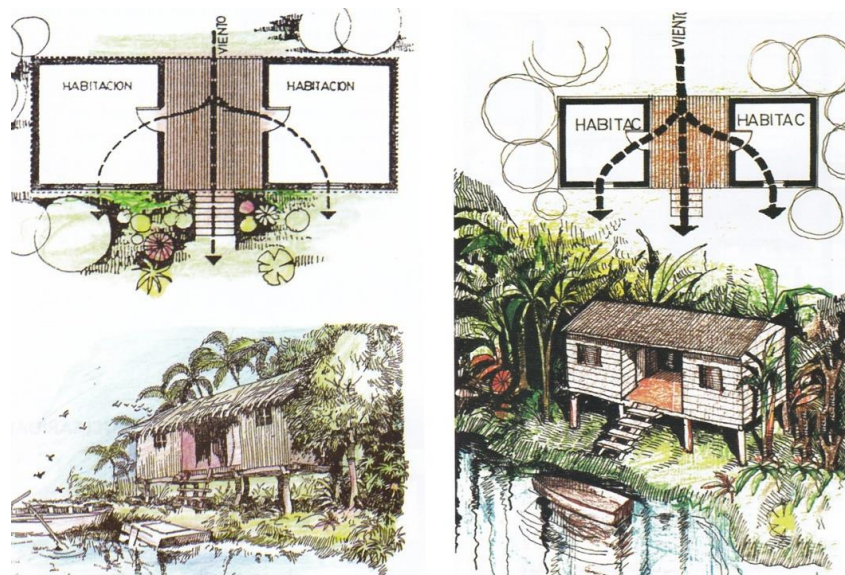

Fig. 3. Argentina subtropical area: typical rural housings (Carli C L, [10])

In order to contain costs and simplify the whole process, the proposed system allows the construction of e.g. an entire house through the use of the same multi-layer wood panel. This logic of unification and simplification facilitates both the manufac-

turing, which is faster and more sustainable (less waste), as well as warehouse management, and the construction phase, with greater simplicity of supply and speed of assembly. The size of the panel also favors quick assembly (no winches or cranes are needed and everything can be completed by a couple of workers), resulting in lower costs for both site management and components procurement [12, 13].

All the elements of which the multilayer panel is made of are illustrated and catalogued in Table 1.

From the cut of the C element of which the multi-layer wood panel is composed, it is possible to make additional solid wood elements, which are depicted and catalogued in Table 2 below, again with an approach to simplifying production and limiting material waste. The latter are used to assemble the portals with a structural function, suitably braced by the multi-layer wood panel, which combines the bracing function with that of external closure: the same panel is, moreover, used to make the entire envelope of the house (floor, external walls, roofing) and any partitions with its lesser thicknesses.

Table 1. Multi-layer wood panel manufacturing steps: (a) from the logs of the production forests, all the necessary material, including wood fiber for the insulation panel, is obtained in the supply chain and waste minimized; (b) (c) exploded views of the panel (see element list in the lower part of the table); (d) complete multi-layer wood panel

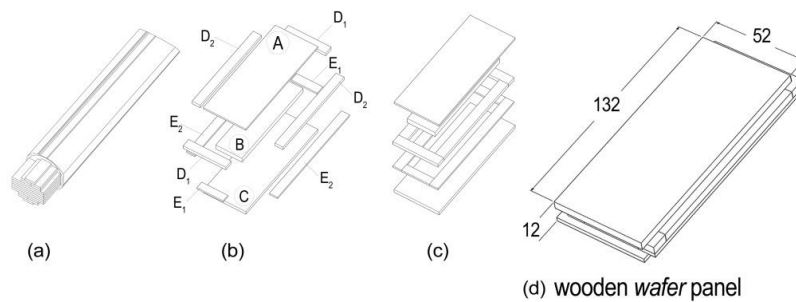

wooden wafer panel function: bracing and infill panel (floor, vertical and roof envelope)			
cod.	dim. LxDxH [cm]	material	No. of panels needed:
A	132x52x2	solid wood	Floor: 90
B	112x32x6	wood wool	Vertical envelope: 168
C	132x52x4	solid wood	Roof: 126
D ₁	52x10x4 (No. 2)	solid wood	Total: 384*
D ₂	112x10x4 (No. 2)	solid wood	
E ₁	32x10x2 (No. 2)	solid wood	*No. of wafer panels needed to build the proposed dwelling model
E ₂	132x10x2 (No. 2)	solid wood	



The inner side of the building envelope can also be completed with electricals, fittings, piping etc., also to enable building’s energy self-sufficiency (e.g., photovoltaics, thermal solar panels) and finishing materials (plasterboard, matchboarding, flooring,

etc.) even at a later stage, because as supplied the assembled system allows immediate use of the volumes as soon as the windows and doors are placed. This also makes it usable in cases of immediate relief or for the construction of temporary buildings (exhibition stands, mobile construction sites, etc.). Furthermore, the reiteration of the elementary cell can give rise to multi-family buildings, small schools, clinics, service centers, etc.

The small size of the elements of which the system is composed allows them to be transported even by common vans, facilitating their distribution even in the most decentralized rural areas that could achieve a sustainable housing development and benefit from the “connected society” distributed chances: all the elements for this dwelling, repeating the traditional rural houses scheme of two compartments and central gallery, can be transported with a couple of trips of a tractor-trailer: it is a matter of transporting about 40 tons of material with a footprint of about 50 m³.

On the other hand, the intrinsic characteristics of the system, in accordance with the requirements of the mentioned “Manual of Sustainable Construction” make it easily deconstructible and transportable elsewhere, as well as fully reusable and recyclable, with the exception of only the pair of masonry baffles that are needed for the interface of the house with the ground. De-constructability and transportability, due to dry assembly and the small size of the elements that make up the system, is also advantageous in terms of reliability of investment for the house: in the case of relocation, the *vivienda* can be moved elsewhere, without the need to be resold on site, perhaps in a market condition where demand is weak and the price would not be adequate for the original resource commitment. So doing, the soil usage is almost reversible and the ghost house phenomenon avoided.

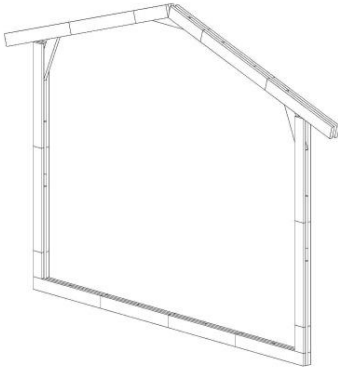
Table 2. List of the additional solid wood elements for house portals (they are all obtained by appropriate cutting of the “C” elements)

	cod.	dim. LxDxH [cm]	Function: structural portals
	C ₁ (C/3)	132x17x4	
	C ₂ (C ₁ /2)	66x17x4	
	C ₃ (C ₂ /2)	33x17x4	

7 Sustainability and house energy equipment

The energy transition asks people to change the model of production and consuming to achieve a Positive Anthropogenic Impact (PAI) on the environment. Therefore, policies are required for the efficiency of consumption, production, transmission and distribution of energy and the increase in the production mix from renewable sources, considered to have a low climate impact. All buildings contribute to the city's sustainability, and the wafer wood panel building system is no exception; this is why the proposed house design was geared toward reducing energy needs and environmental impact, both in the manufacturing and construction process and during its life.

In facts, as elementary bit of the city fabric, the wafer wood panel house is in close relationship with its physical and social neighborhood, connected with the district network systems and relied also upon Energy Communities (i. e. a socio-economic model consisting in a consortium of users, focused on the decentralization and local exchange of energy, according to the principles of circularity, and aimed to self-produce from renewable sources, consume and manage energy through one or more local energy plants, in order to achieve energy self-sufficiency). It is not a matter of connection only, but also of the way of connection.

Smart cities are made of smart behaviors of each member: a building can not take whatever it needs at any time, and so the first rule should be to reduce as much as possible the energy footprint on the town.

For this reason, electrical, HVAC, and plumbing systems are integrated into the same design and such as to decrease the house's energy footprint to city grids (see Fig. 4): on sunny hours, the rooftop generates electricity through a photovoltaic-battery-inverter system; during rainy days, the rooftop collects rainwater that the downspouts do not convey into the city sewer system (avoiding its overloading), but take it to a large underground reservoir, where it can be used in the part exceeding the minimum operating level in the tank for toilet flushing but mostly stored as a closed-loop heat sink to feed the water-to-water heat pump. During dry periods, the heat-pump uses water stored in the reservoir as a closed water loop and "thermal flywheel" to exchange energy to the ground [14].

In daylight hours, the system will operate almost off-grid, while the closed loop of rainwater for the heat pump is made to facilitate energy exchange to the ground as well. Any PV production during stand-by periods of the heat pump will be sold via smart connection to an energy community through the city grid or stored in battery packs.

The Argentine Board of Construction (Cámara Argentina de la Construcción) has estimated [15] that the average electricity requirement (Heat Pump excluded) of sustainable social housing is about 1.5 MWh per year. A photovoltaic array of 1.16 kWp can generate about 1.6 MWh/year in Buenos Aires and 2 MWh/year in Mendoza, being sufficient for the general electricity demand, while the photovoltaic capacity would have to be about 4 or 3 times higher to cover the heat pump needs as well.

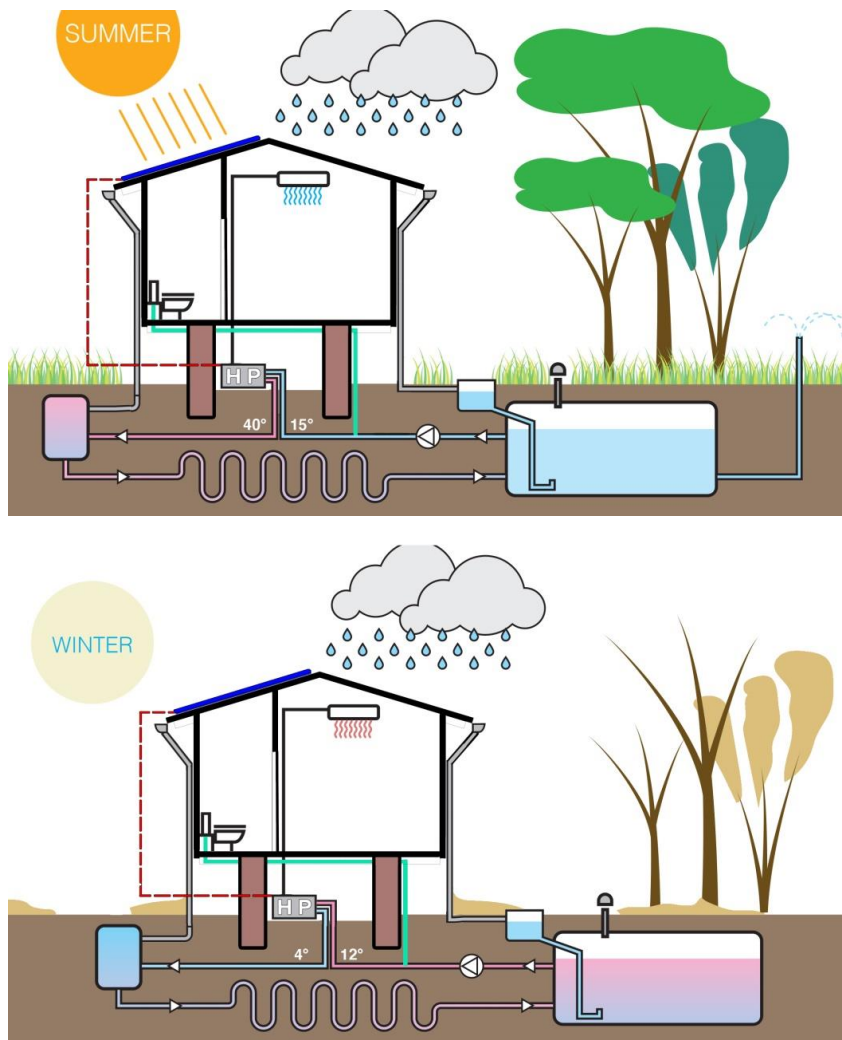

Fig. 4. Scheme for energy and HVAC system in the proposed prefabricated wood dwellings (summer and winter operation).

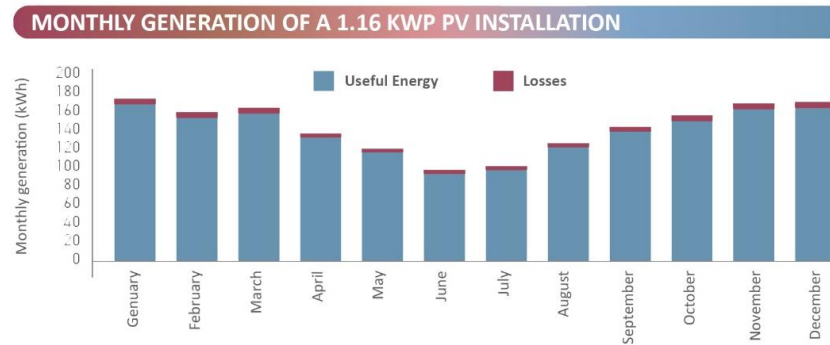

Fig. 5. Monthly simulation for a 1.16kWp PV system in Buenos Aires (1650 kWh/year (± 10)).

8 Conclusions

The energy transition asks people to change the model of production and consuming to achieve a Positive Anthropogenic Impact (PAI) on the environment. Therefore, policies are required for the efficiency of consumption, production, transmission and distribution of energy and the increase in the production mix from renewable sources, considered to have a low climate impact. All buildings contribute to the city’s sustainability, and the wafer wood panel building system is no exception; this is why the proposed house design was geared toward reducing energy needs and environmental impact, both in the manufacturing and construction process and during its life: the de-constructible house can also be enlarged or reduced in size according to users’ needs and can be disassembled, moved, and assembled elsewhere, reducing the impact of abandoned houses.

In facts, as elementary bit of the city fabric, the wafer wood panel house is in close relationship with its physical and social neighborhood, connected with the district network systems and relied also upon Energy Communities (i. e. a socio-economic model consisting in a consortium of users, focused on the decentralization and local exchange of energy, according to the principles of circularity, and aimed to self-produce from renewable sources, consume and manage energy through one or more local energy plants, in order to achieve energy self-sufficiency). It is not a matter of connection only, but also of the way of connection. Smart cities are made of smart behaviors of each member: a building cannot take whatever it needs at any time, and so the first rule should be to reduce as much as possible the energy footprint on the city grid and the waste of embedded energy. Considering the possibility of volunteers to assemble/disassemble the house, the cost is competitive with that of conventionally built houses; but the main purpose of the proposed system is to enable mobility-reuse of building components: the same costs can thus be amortized two or three times.



Fig. 6. 3D modelling of the proposed wafer wood panel rural house.

References

1. Meeting With Carlos Moreno: Human Smart Cities, <https://www.moreno-web.net/meeting-with-carlos-moreno-human-smart-cities>, last accessed 2022/10/06.
2. Broza D, Rossit Da, Rossit Di, Cavallín A, The Argentinian forest sector: opportunities and challenges in supply chain management. *Uncertain Supply Chain Management* 6, pp. 375–392 (2018).
3. Ministerio de Hacienda, Presidencia de la Nación, Subsecretaría de Programación Microeconómica, Secretaría de Política Económica. *Informes de Cadenas de Valor. Forestal, paper y muebles* (2019).
4. Ministerio del Interior, Obras Públicas y Vivienda de la Nación. Resolución 9-E: Estándares mínimos de calidad para viviendas de interés social. Secretaría de Vivienda y Hábitat. Buenos Aires (2017).
5. Ministerio del Interior, Obras Públicas y Vivienda de la Nación. *Manual de la Vivienda Sustentable*. Subsecretaría de Desarrollo Urbano y Vivienda. Buenos Aires (2018).
6. Secretaría de vivienda y hábitat. Resolución 3-E-2018. Ministerio del interior, obras públicas y vivienda. Buenos Aires, República Argentina (2018).
7. Norma IRAM 11605, Accondicionamiento térmico de edificios condiciones de habitabilidad en edificios. Valores máximos de trasmittancia térmica en cerramientos opacos (1996).
8. Pilar C, Vallejos, S. y Kennedy, E. Casos de construcción de viviendas en entramado de madera de bosques implantados en Corrientes. *Congreso Regional de Tecnología en la Arquitectura*. Mar del Plata, Argentina (2019).
9. Argentina lanza un programa de crédito para construir miles de viviendas nuevas, https://el-pais.com/economia/2012/06/13/actualidad/1339544540_890839.html, last accessed 2022/10/06.
10. Carli C L, *La Casa. El Espacio y la Distancia. Las nuevas teorías*. Editor literario César Luis Carli, 1° ed. Ilustrada, Santa Fe (2017).
11. Sartorio R, Siniak M, Investigación sobre la vivienda rural en el nordeste de la República Argentina y propuesta para el déficit actual, *Informes de la Construcción*. Vol. 36, n.º 361, junio (1984).
12. Bagnato F., *Processi edilizi in autocostruzione assistita. Una risposta al problema abitativo delle fasce deboli*, Iiriti Editore, Reggio Calabria (2002).
13. Grahame A, McKean J, Walter Segal: *Self-Built Architect*. Lung Humphries, London (2021).
14. Rollin K, *Ground Source Heat Pumps. A Low-Carbon Energy Technology*. *Energy Resources*. 12 (1), 10-19 (2010).
15. Silvina Carrizo S, Azqueta P, Strier, Gil S, *Vivienda social sostenible*, Cámara Argentina de la Construcción, CABA (AR) (2021).