

Monitoring systems for railways freight vehicles

Original

Monitoring systems for railways freight vehicles / Bosso, N., Magelli, M., Zampieri, N.. - In: THE INTERNATIONAL JOURNAL OF COMPUTATIONAL METHODS AND EXPERIMENTAL MEASUREMENTS. - ISSN 2046-0546. - ELETTRONICO. - 10:4(2022), pp. 359-371. [10.2495/CMEM-V10-N4-359-371]

Availability:

This version is available at: 11583/2974730 since: 2023-05-25T09:38:11Z

Publisher:

WIT Press

Published

DOI:10.2495/CMEM-V10-N4-359-371

Terms of use:

This article is made available under terms and conditions as specified in the corresponding bibliographic description in the repository

Publisher copyright

WIT Press postprint versione editoriale/ Version of record con copyright WIT Press

© WIT Press 2022. Monitoring systems for railways freight vehicles / Bosso, N., Magelli, M., Zampieri, N.. - In: THE INTERNATIONAL JOURNAL OF COMPUTATIONAL METHODS AND EXPERIMENTAL MEASUREMENTS. - ISSN 2046-0546. - ELETTRONICO. - 10:4(2022), pp. 359-371. [10.2495/CMEM-V10-N4-359-371].

(Article begins on next page)

MONITORING SYSTEMS FOR RAILWAYS FREIGHT VEHICLES

NICOLA BOSSO¹, MATTEO MAGELLI[†] & NICOLÒ ZAMPIERI[‡]
Department of Mechanical and Aerospace Engineering, Politecnico di Torino, Italy.

ABSTRACT

Monitoring systems are a key tool to improve the safety of railway vehicles and to support maintenance activities. Their on-board application on railway vehicles is currently well established on newly built passenger vehicles, while their use on freight vehicles is not yet sufficiently widespread. This is due to the complex management of the operating procedures of the freight wagons, to the substantial impact of the cost of these systems compared to the cost of the wagon and to the common lack of electrification on freight wagons.

This work illustrates the characteristics of a monitoring system developed at Politecnico di Torino and previously installed on freight vehicles and operationally tested as regards the detection of accelerations and temperatures as diagnostic parameters. This system has been improved by adding diagnostics of the vehicle braking system, in order to detect anomalies during braking operations and to support maintenance procedures. The activity described in the present work aims to identify, beyond the specific diagnostic system that has been implemented, the basic characteristics that a modern monitoring system, intended to be installed on railway freight wagons, should feature. The new version of the monitoring system that has been developed at Politecnico di Torino has been preliminarily tested on a scaled roller-rig in order to monitor the braking system even in abnormal operating conditions, which would be difficult to reproduce safely on a real vehicle. The monitoring system is equipped with an axle generator capable of autonomously supporting its operation, and it is also provided with a diagnostic information processing system and communication protocols to send outside this information.

Keywords: diagnostic systems, onboard monitoring systems, railway monitoring.

1 INTRODUCTION

The use of monitoring systems in the railway sector can be adopted for different purposes. For instance, these systems allow to detect any anomalies or failures both on vehicles and on the infrastructure, and this significantly contributes to an improvement of the safety of the railway transport system [1]. The prompt identification of major failures or defects, both on vehicle and infrastructure components [2, 3], can in fact prevent the risk of derailment [4] if the information obtained from the monitoring system is used effectively to undertake mitigating measures, such as the interruption of the line traffic or the stop of the vehicle. A second important function of monitoring devices is to assist and guide maintenance interventions based on the deterioration conditions detected on the vehicle or infrastructure components. The correct integration of the monitoring system with the maintenance procedures adopted by the vehicle keeper (for the vehicle) or by the infrastructure manager (for the infrastructure) can allow the shift of maintenance procedures from a time or kilometric schedule to an on-condition approach. This second method enables to repair or replace components only when it is necessary, allowing to reduce operating costs while improving safety, efficiency, and availability during operation.

¹ ORCID: <https://orcid.org/0000-0002-5433-6365>

[†] ORCID: <https://orcid.org/0000-0002-2962-7873>

[‡] ORCID: <https://orcid.org/0000-0002-9197-1966>

Monitoring systems can basically be classified into two main categories: wayside [5–7] and onboard [8–11] monitoring systems, with the latter type being the one analyzed in this work. Fixed (wayside) monitoring systems are present in the railway sector with several well-established applications that normally have the function of detecting critical defects in vehicles, such as detection systems for hot bearings, or for defects in wheel rolling surfaces, weighting of axles, etc. These systems are therefore used to suspend some vehicles from circulation, but they intervene when the defect on the vehicle is already evident. However, since the detection stations are located in specific positions on the track, such devices cannot guarantee prompt intervention in the event of sudden failures along the line, nor can they provide information support to the vehicle maintenance system.

Innovative fixed detection systems are being studied based on image processing techniques or acoustic/vibrational analysis [12, 13], which should make it possible to extend the field of investigation to other aspects of the rolling stock such as the gauge, the load, the suspensions, and also to evaluate the degradation of components in a predictive manner. In some applications, fixed systems can be used to monitor the conditions of parts of the infrastructure (e.g. bridges or curves subject to high wear). Nonetheless, these fixed systems maintain the limitation of requiring the passage of the rolling stock on the measuring apparatus in order to provide information and the vehicle passage window is extremely reduced compared to the life of the vehicle on the track.

For this reason, the use of monitoring systems mounted on board vehicles has several advantages. In fact, this solution allows to monitor the conditions of the vehicle in real time. Onboard diagnostic systems can also be conveniently used for infrastructure monitoring, in fact, infrastructure managers use special diagnostic vehicles to periodically check the conditions of the line (ballast and track) and of the other infrastructure components (tunnels, bridges, and catenary) by means of different types of sensors.

As for the vehicle diagnostic functions, which are the main object of this work, onboard systems have been widely used starting with passenger vehicles, particularly in high-speed vehicles where vehicle performance must be constantly monitored [14]. Various monitoring applications have been applied to locomotives, where the importance of traction control [15, 16] is particularly relevant and where different diagnostic support systems are already necessarily present.

The adoption of onboard monitoring systems on freight vehicles is not yet particularly developed, especially since freight vehicles are normally devoid of electrification and data transmission channels. Nevertheless, the use of diagnostic systems on freight vehicles is of particular interest due to the lower maintenance and control frequency to which these vehicles are subject. For this reason, there are several studies for the development of monitoring systems for freight vehicles [17], which, in order to be of interest, must be energetically autonomous and low cost so as not to significantly impact the cost of the wagon.

Essentially, two solutions can be used to instrument a freight wagon and create a diagnostic monitoring system. The first strategy is to follow the approach traditionally used also on passenger vehicles by equipping the vehicle with one or more data acquisition and processing units connected to a series of sensors by wired connections. This solution normally requires a greater amount of energy that can be supplied for example by an axle generator, if not directly powered by the locomotive. The second solution is the creation of a network of independently self-powered wireless sensors, powered by dedicated energy harvesters [18]. The sensor network normally requires a concentrator capable of conveying the data coming from all the sensors that make up the nodes of the

network and possibly processing them. The concentrator also needs an energy harvesting system. Wireless-type systems are more versatile as regards their installation on the vehicle, but normally the amount of data that they are able to transmit and the sampling frequency that they can adopt are limited. Therefore, they require simplified diagnostic algorithms and thus they currently feature limitations as regards the diagnostic functions that can be implemented. However, with the technological evolution in the field of ultra-low power sensors and microcontrollers, an improvement in the diagnostic capabilities of these systems can also be expected in the future, making them very promising for future applications. The traditional (wired) systems have greater assembly complexity and higher overall costs, but currently they allow greater processing and data storage capacity, which is only limited by the type of sensors chosen and the system architecture. Therefore, they are currently the ideal basis for developing reliable and comprehensive diagnostic systems that may be converted into wireless systems in the future. For this reason, the solution adopted for the application developed at the Politecnico di Torino is based on a wired system, in such a way as to be able to develop an adequate set of sensors and process them using appropriate diagnostic algorithms not bound by the limits of the monitoring architecture.

This work illustrates the recent upgrades made to the monitoring system developed by the Politecnico di Torino research group in previous years and already tested on various types of freight vehicles [19–21]. The new changes aim at implementing new diagnostic features on several vehicle components, such as those related to the traditional air brake system installed on freight wagons [22].

2 MONITORING SYSTEM DESCRIPTION

The monitoring system designed at the Politecnico di Torino is the result of various evolutions starting from an initial architecture consisting of an extremely modular system based on an intelligent multiplexer with redirection of the signals coming from the sensors to appropriate signal conditioning devices and using a limited number of channels. Later on, thanks to the availability of new multichannel A/D converters, the original system was modified, and the upgraded version was based on a microcontroller managing several simultaneous acquisition channels. Initially, this version was designed to acquire mainly Integrated Circuit Piezoelectric (ICP) accelerometers. Currently, the system has been further modified by adding to the previously used channels a series of additional acquisition channels designed for sensors requiring a lower sampling rate with respect to the one demanded by accelerometers and which will be dedicated to monitoring the braking system. The system is also equipped with a GPS tracking device. The system configuration in its current version, which has been designed for installation on freight vehicles, is described below.

2.1 System architecture

The basic architecture of the system is represented in Fig. 1, which shows the sensors (S) installed on the wagon, with wired connection to the monitoring unit (MU), which supplies the sensors and performs the signal conditioning and the data acquisition operations.

Since the MU is governed by a microcontroller (LPC2478) which is, for reasons of cost and energy consumption, not able to simultaneously acquire all the channels at the maximum sampling frequency, different monitoring programs can be launched alternately, in order to execute different diagnostic functions on different vehicle components.

In addition, the system includes the following:

- Three capacitive accelerometers installed directly on the monitoring board, which is mounted on the vehicle car body.
- One ambient reference thermal sensor, located near the monitoring board (away from internal heat sources).
- One biaxial inclinometer with capacitive technology mounted in the car body frame, to detect the roll and pitch angles (mounted on a single monitoring board if there are two boards on the vehicle).

The measurements of the ICP sensors are acquired through high-frequency acquisition channels based on the AD7608 ADC (18 bits up to 200 kS/s per channel). For the other sensors, a solution was chosen with a lower frequency A/D converter type ADS1148 (16 bits, 2 kS/s).

2.3 System update

The monitoring system has recently been updated to add the possibility of analyzing further important subsystems of the railway freight vehicle and in particular the braking system. The components of the braking system are mainly pneumatic components, which require the installation of pressure sensors. The dynamics of braking and related pneumatic devices are characterized by phenomena that occur at low frequencies; therefore, the monitoring of the braking system does not demand for acquisition channels with a high sampling rate.

Therefore, an additional ADS1148 A/D converter, previously not installed, but whose presence had already been foreseen, has been added to the monitoring board.

The additional channels are used to monitor the following sensors:

- Pressure in the main brake pipe
- Pressure at the brake cylinder
- Pressure at the auxiliary reservoir
- Brake pad temperature

Furthermore, the following additional information can be acquired:

- Pressure at the command reservoir
- Pressure at the emergency reservoir
- Pilot pressure to empty/load braking valve
- Pressure from weighing cells

In addition, the card has been equipped with an integrated GPS, which is able to provide the geolocation of the vehicle in real time and to save this position, together with the vehicle speed, in the data acquired by the system. Figure 2 shows the updated version of the MU board.

3 MONITORING FUNCTIONS

The monitoring system includes various functions that can be divided into two levels: safety functions and maintenance support functions. The first type of functions allows for the timely detection of serious anomalies that can cause danger to railway traffic and must therefore be

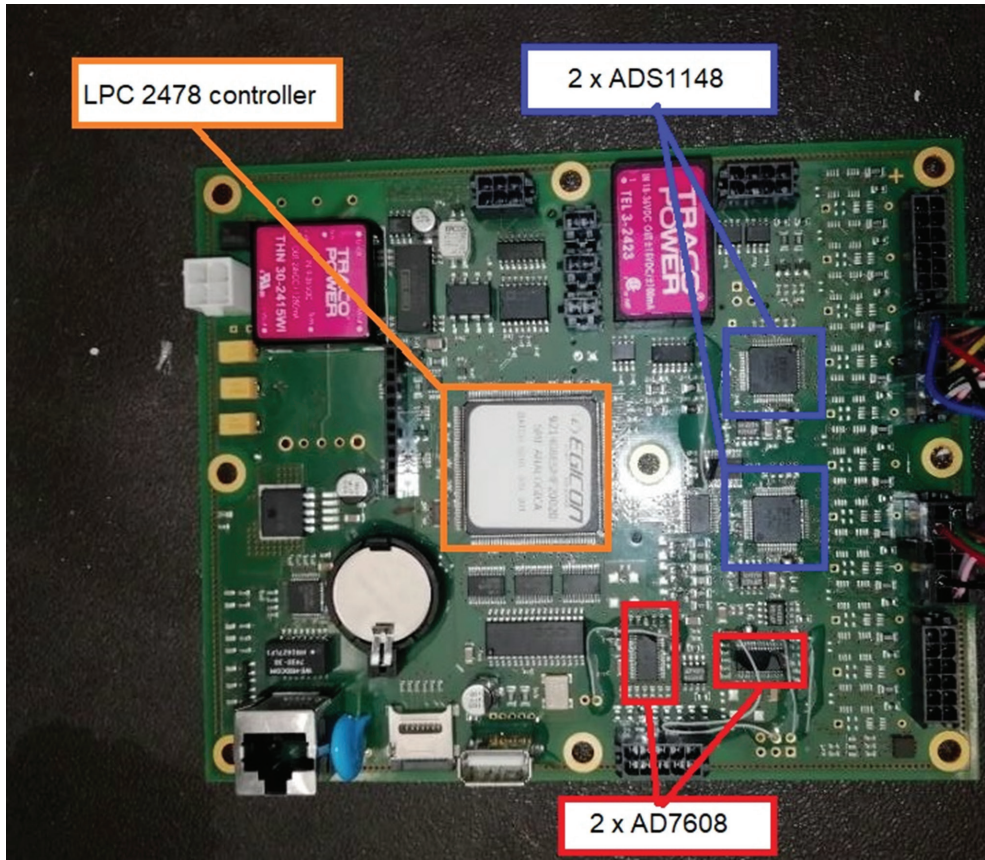

Figure 2: Latest version of the board with the additional components highlighted.

active in real time. The maintenance-related functions are instead activated periodically and allow to evaluate the state of deterioration of the vehicle components.

3.1 Safety functions

The system provides different functions for monitoring the vehicle running safety, which are summarized as follows:

- Derailment (occurred): this condition is detected by an algorithm that analyzes the vertical accelerations measured in the axle-boxes in relation to the vehicle speed.
- Serious structural damage to the vehicle wheels: this condition is also detected relying on accelerometric measurements in the vertical direction.
- Integrity of the vehicle suspensions: this condition is detected analyzing the transfer function between the axle-boxes and the wagon frame resulting from the accelerometric measurements.

All the above functions based on accelerometric measurements are activated automatically if the vertical accelerometers (constantly monitored) exceed a threshold value in terms of root mean square (rms) acceleration.

The system is also provided with the following main functions, which do not require accelerometric measurements:

- Bearing integrity: this function is based on the thermal measurements performed in the axle-boxes, and an alarm signal is produced when the sensors detect the temperature exceeding a safety threshold value.
- Braking faults (not required or anomalous): this function is based on the temperature measurement carried out on the brake shoes and detects whether a shoe remains close to the wheel in a release condition or if the shoe temperature reaches an excessive value.
- Serious malfunction of the braking system: this function detects the mismatch between the pressure at the brake cylinder and the depression in the brake pipe or between the pressure at the brake cylinder and the braking action highlighted by the increase in shoe temperature. This function detects whether an axle/bogie is not braking when a braking operation is activated.

3.2 Maintenance support

The functions monitoring the degradation level of vehicle components or the overall dynamics of the vehicle are obtained by means of algorithms that are activated periodically and rely on different combinations of sensors. In this case, the results of the monitoring algorithms produce synthetic indicators of the degradation level that are saved at periodic intervals on a non-volatile memory (SD) integrated in the MU. The comparison between the values assumed by these indicators in different times allow to evaluate the evolution of the state of degradation of the components, providing useful information for maintenance. The surveillance functions that have been implemented include the following:

- Conditions of the rolling surfaces of the wheels (wheel-flat) [23] based on an accelerometric analysis.
- State of degradation of the bearings, based both on the analysis of operating temperatures and on vibrational analysis.
- State of degradation of the suspensions, based on the transfer function between axle-box and wagon frame accelerations.
- Anomalies of the braking system, based on an evaluation of the temperatures at the shoes and of the pressures in the pipeline, at the brake cylinder and at the additional sensors if present.
- Degradation of the ride index of the vehicle, on an accelerometric basis.

The system also allows to detect any critical damage of the infrastructure related to specific positions on the track.

4 TESTING OF THE SYSTEM

4.1 Testing on the track

The monitoring system was tested on the Velim test track, where fault conditions can be simulated in safety conditions. The tests allow to assess the monitoring functions and to calibrate the algorithms. Figure 3 shows the monitoring system installed on the freight test vehicle equipped with the Y25 bogie.



Figure 3: Monitoring system installed on the freight test vehicle in Velim.

The tests performed on the Velim test track investigated the response of the monitoring system to the following aspects:

- Wheel flat.
- Repeated vertical irregularities (cyclic top), see Fig. 4a.
- Derailment, see Fig. 4b.
- Stability, see Fig. 4c.

A second experimental campaign was performed on a real track with focus on the evaluation of the track quality [24]. More in detail, tests were carried on the traditional Gotthard line and on the new high-speed Gotthard line in collaboration with SBB and Hupac SA. The experimental campaign allowed to compare the performance of the two tracks by analyzing the accelerations acquired by the monitoring system. Figure 5 shows the freight vehicle equipped with the monitoring system during the experimental campaign.

4.2 Testing on roller-rig

On-field testing of monitoring systems can be a complex task, as the simulation of failure conditions may be too dangerous. Nonetheless, monitoring algorithms and systems must be tested and validated to ensure their reliability and effectiveness. Therefore, the research group investigated the possibility of validating the new monitoring system, able to detect the conditions of the brake system components, by means of laboratory test rigs [25–28]. The new MU provided with functions for the brake system monitoring was tested on innovative scaled multi-axle roller-rig [29–32], which was originally designed to investigate degraded adhesion conditions and adhesion recovery phenomena [33]. The roller-rig mechanical structure includes two rollers, powered by a single brushless motor, and four wheelsets. Each wheelset is equipped with two brake disc-brake pad pairs, that allow to set a braking torque. The original architecture was modified to simulate the brake plant of a freight wagon. Currently, for the sake of simplicity, only one wheelset was supplied with compressed air to reproduce a braking operation, but in future upgrades, the braking torque could be easily obtained on each wheelset. Figure 6a shows a schematic view of the braking plant reproduced on the bench,

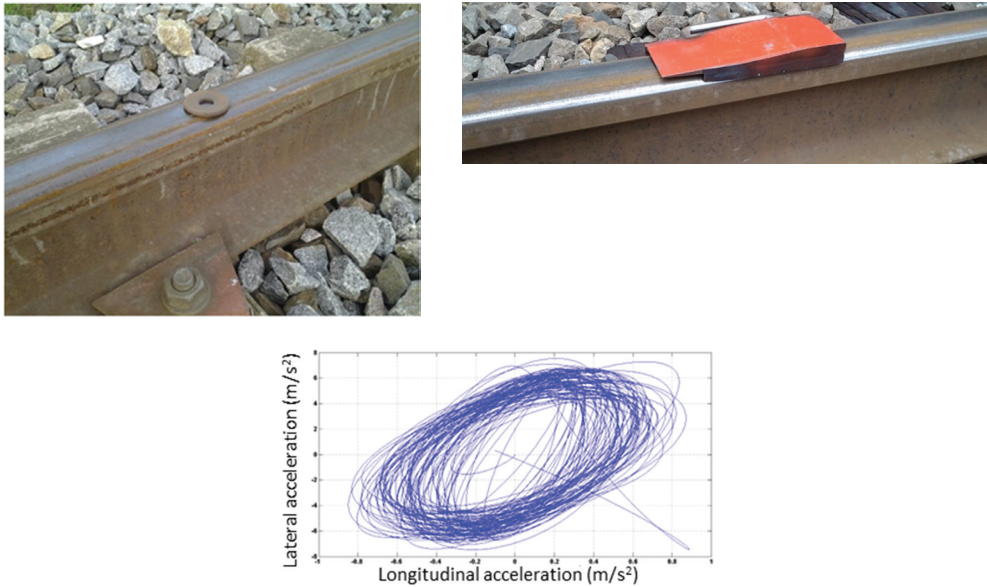

Figure 4: Tests of the monitoring system performed on the Velim test track. (a) System for the simulation of vertical irregularities; (b) System for the simulation of vehicle derailment; (c) Stability diagram obtained during the experimental tests.



Figure 5: Monitoring system installed on the vehicle during the test on the Gotthard high-speed track.

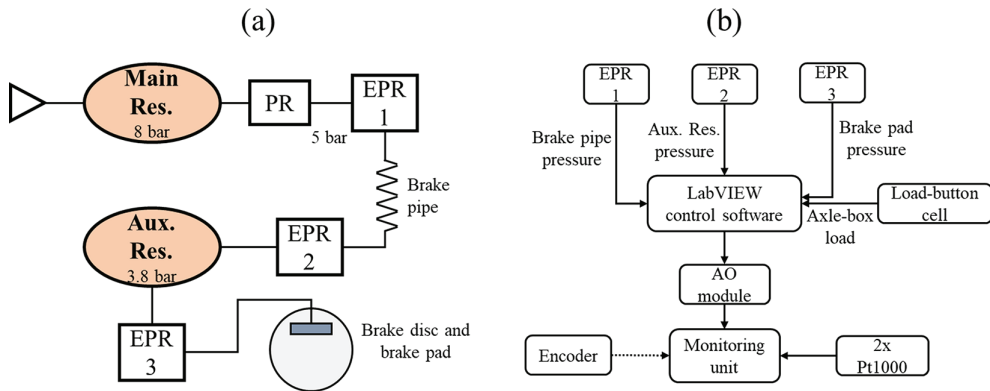

Figure 6: Testing of the MU by means of a roller-rig. (a) Scheme of the pneumatic plant; (b) Communication among sensors, MU, and control software (dotted line for digital signals).

while Fig. 6b sketches the communication between the MU and the other sensors installed on the bench.

A main reservoir is used to stock compressed air at a pressure of 8 bar, while a pressure reducer sets the pressure downstream at the nominal value of 5 bar. The main brake pipe is simply reproduced by means of a long pipe, used as a pneumatic resistance, which allows to simulate the delay of the pressure wave along the train consist. The pressure in the brake pipe is adjusted by means of an electro-pneumatic regulator (EPR 1) that allows to set a pressure drop to start a braking operation. Downstream of the brake pipe is a reservoir, simulating the auxiliary reservoir, whose pressure is regulated by means of a second electro-pneumatic regulator (EPR 2). Finally, a third regulator (EPR 3) is used to adjust the pressure at the brake calipers installed on the braked wheelset. The value of the braking pressure is computed as a function of the pressure measured in the brake pipe.

The bench is managed by means of a dedicated control software, implemented in LabVIEW, which manages the braking operations simulated on the roller-rig. The control software allows to reproduce a realistic stop braking operation, as it estimates the deceleration of the vehicle at each time step starting from the measurements of the tangential force acting at each disc-pad interface.

The control software also manages an analog output module which sends to the MU installed on the bench the same parameters that the unit would receive when installed on board the vehicle. More in detail, the analog output card transmits the signals corresponding to the pressure at the brake pipe, at the auxiliary reservoir and at the brake calipers, as well as the signal of a load button cell which measures the weight acting on an axle-box, thus mimicking the weighing sensor installed on the real vehicles. Moreover, the MU directly receives the digital signals of the encoder installed on the braked wheelset and the signals recorded by the Pt1000 thermistors installed on the brake calipers of the braked wheelset.

Experimental tests reproducing different braking operations characterized by different values of maximum pressure drop in the brake pipe and of the pressure drop gradient were carried out on the bench, and the new configuration of the roller-rig proved to be a reliable tool for the laboratory validation and testing of monitoring algorithms [27, 28].

5 CONCLUSIONS

This work illustrated the recent activities carried out at the Politecnico di Torino to develop a monitoring system to be installed onboard on freight vehicles. The recent changes implemented in the system also allow to monitor the functions of the braking system, which plays a fundamental role in the safety of the vehicle. It was therefore demonstrated how it is possible to integrate functions and algorithms concerning different subsystems in a single MU, thus being able to obtain an overview of the vehicle conditions. The installation of a geolocation system also makes it possible to refer to the position of any anomalies and possibly to correlate them with defects on the track, excluding a malfunction of the vehicle.

The sharing of the diagnostic data obtained in real time with the driver and with the vehicle keeper allows an improvement in the safety of the railway system and an improvement of the maintenance system.

REFERENCES

- [1] Ngigi, R. W., Pislaru, C., Ball, A. & Gu, F., Modern techniques for condition monitoring of railway vehicle dynamics. *Journal of Physics: Conference Series*, **364**, 2012. <https://doi.org/10.1088/1742-6596/364/1/012016>
- [2] Bernal, E., Spiryagin, M. & Cole, C., Onboard condition monitoring sensors, systems and techniques for freight railway vehicles: A review. *IEEE Sensors Journal*, **19**(1), pp. 4–24, 2019. <https://doi.org/10.1109/JSEN.2018.2875160>
- [3] Falamarzi, A., Moridpour, S. & Nazem, M., A review on existing sensors and devices for inspecting railway infrastructure. *Jurnal Kejuruteraan*, **31**(1), pp. 1–10, 2019.
- [4] Cherkashin, U. M., Zakharov, S. M. & Semechkin, A. E., An overview of rolling stock and track monitoring systems and guidelines to provide safety of heavy and long train operation in the Russian Railways. *Proceedings of the Institution of Mechanical Engineers, Part F: Journal of Rail and Rapid Transit*, **223**(2), pp. 199–208, 2009. <https://doi.org/10.1243/09544097jrrt226>
- [5] Barke, D. & Chiu, W. K., Structural health monitoring in the railway industry: A review. *Structural Health Monitoring*, **4**(1), pp. 81–93, 2005. <https://doi.org/10.1177/1475921705049764>
- [6] Bracciali, A., Wayside train monitoring systems: A state-of-the-art and running safety implications. *International Journal of Railway Technology*, **1**(1), pp. 231–247, 2012.
- [7] Mosleh, A., Montenegro, P. A., Costa, P. A. & Caçada, R., Railway vehicle wheel flat detection with multiple records using spectral kurtosis analysis. *Applied Sciences*, **11**(9), p. 4002, 2021.
- [8] Bocciolone, M., Caprioli, A., Cigada, A. & Collina, A., A measurement system for quick rail inspection and effective track maintenance strategy. *Mechanical Systems and Signal Processing*, **21**(3), pp. 1242–1254, 2007. <https://doi.org/10.1016/j.ymssp.2006.02.007>
- [9] Tsunashima, H., Mori, H., Yanagisawa, K., Ogino, M. & Asano, A., Condition monitoring of railway tracks using compact size on-board monitoring device. *Presented at 6th IET Conference on Railway Condition Monitoring (RCM 2014)*, Birmingham (UK), 2014. <https://doi.org/10.1049/cp.2014.0996>.
- [10] Li, C., Luo, S., Cole, C. & Spiryagin, M., An overview: Modern techniques for railway vehicle on-board health monitoring systems. *Vehicle System Dynamics*, **55**(7), pp. 1045–1070, 2017. <https://doi.org/10.1080/00423114.2017.1296963>
- [11] Chudzikiewicz, A., Bogacz, R., Kostrzewski, M. & Konowrocki, R., Condition monitoring of railway track systems by using acceleration signals on wheelset axle-boxes. *Transport*, **33**(2), pp. 555–566, 2018. <https://doi.org/10.3846/16484142.2017.1342101>

- [12] He, Q., Wang, J., Hu, F. & Kong, F., Wayside acoustic diagnosis of defective train bearings based on signal resampling and information enhancement. *Journal of Sound and Vibration*, **332**(21), pp. 5635–5649, 2013. <https://doi.org/10.1016/j.jsv.2013.05.026>
- [13] Amini, A., Entezami, M., Huang, Z., Rowshandel, H. & Papaalias, M., Wayside detection of faults in railway axle bearings using time spectral kurtosis analysis on high-frequency acoustic emission signals. *Advances in Mechanical Engineering*, **8**(11), 2016. <https://doi.org/10.1177/1687814016676000>
- [14] Oba, T., Yamada, K., Okada, N. & Tanifuji, K., Condition monitoring for shinkansen bogies based on vibration analysis. *Journal of Mechanical Systems for Transportation and Logistics*, **2**(2), pp. 133–144, 2009. <https://doi.org/10.1299/jmtl.2.133>
- [15] Spiryagin, M., Lee, K. S. & Yoo, H. H., Control system for maximum use of adhesive forces of a railway vehicle in a tractive mode. *Mechanical Systems and Signal Processing*, **22**(3), pp. 709–720, 2008. <https://doi.org/10.1016/j.ymsp.2007.09.018>
- [16] Spiryagin, M., Cole, C. & Sun, Y. Q., Adhesion estimation and its implementation for traction control of locomotives. *International Journal of Rail Transportation*, **2**(3), pp. 187–204, 2014. <https://doi.org/10.1080/23248378.2014.924842>
- [17] Somà, A., Aimar, M. & Zampieri, N., Simulation of the thermal behavior of cast iron brake block during braking maneuvers. *Applied Sciences*, **11**(11), 2021.
- [18] Bosso, N., Magelli, M. & Zampieri, N., Application of low-power energy harvesting solutions in the railway field: A review. *Vehicle System Dynamics*, **59**(6), pp. 841–871, 2021. <https://doi.org/10.1080/00423114.2020.1726973>
- [19] Zampieri, N., Bosso, N. & Gugliotta, A., Innovative monitoring systems for onboard vehicle diagnostics. *Civil-Comp Proceedings*, **110**, 2016.
- [20] Bosso, N., Gugliotta, A. & Zampieri, N., Design and testing of an innovative monitoring system for railway vehicles. *Proceedings of the Institution of Mechanical Engineers, Part F: Journal of Rail and Rapid Transit*, **232**(2), pp. 445–460, 2018. <https://doi.org/10.1177/0954409716675005>
- [21] Bosso, N., Gugliotta, A., Magelli, M. & Zampieri, N., Monitoring of railway freight vehicles using onboard systems. *Procedia Structural Integrity*, **24**, pp. 692–705, 2019. <https://doi.org/10.1016/j.prostr.2020.02.061>
- [22] Wu, Q., Cole, C., Spiryagin, M., Chang, C., Wei, W., Ursulyak, L., et al., Freight train air brake models. *International Journal of Rail Transportation*, pp. 1–49, 2021. <https://doi.org/10.1080/23248378.2021.2006808>
- [23] Bosso, N., Gugliotta, A. & Zampieri, N., Wheel flat detection algorithm for onboard diagnostic. *Measurement*, **123**, pp. 193–202, 2018. <https://doi.org/10.1016/j.measurement.2018.03.072>
- [24] Bosso, N., Gugliotta, A. & Zampieri, N., Different dynamic track excitations on freight vehicles running on high speed and traditional lines detected with onboard diagnostic systems. *The Dynamics of Vehicles on Roads and Tracks*, pp. 867–872, 2018.
- [25] Bosso, N., Gugliotta, A. & Zampieri, N., Design of a test rig for railway Axleboxes. *Procedia Structural Integrity*, **12**, pp. 344–352, 2018. <https://doi.org/10.1016/j.prostr.2018.11.082>
- [26] Bosso, N., Gugliotta, A. & Zampieri, N., Study of adhesion and evaluation of the friction forces using a scaled roller-rig. *Presented at 5th World Tribology Congress, WTC 2013*, Torino (Italy), 2014.
- [27] Bosso, N., Magelli, M. & Zampieri, N., Validation of a brake monitoring system using a multi-axle roller-rig. *WIT Transactions on the Built Environment*, pp. 151–162, 2020.

- [28] Bosso, N., Magelli, M. & Zampieri, N., Calibration and development of a multi-axis roller bench for monitoring the braking system of a railway vehicle. *Ingegneria Ferroviaria*, **75(7–8)**, pp. 501–523, 2020.
- [29] Bosso, N., Gugliotta, A. & Zampieri, N., A test rig for multi-wheelset adhesion experiments. *Civil-Comp Proceedings*, **110**, 2016.
- [30] Bosso, N., Gugliotta, A. & Zampieri, N., Study of the wheel-rail adhesion under degraded conditions using a multi-axles roller-rig. *The Dynamics of Vehicles on Roads and Tracks*, pp. 803–808, 2018.
- [31] Bosso, N., Gugliotta, A., Magelli, M. & Zampieri, N., Experimental setup of an innovative multi-axle roller rig for the investigation of the adhesion recovery phenomenon. *Experimental Techniques*, **43(6)**, pp. 695–706, 2019. <https://doi.org/10.1007/s40799-019-00327-x>
- [32] Bosso, N., Magelli, M. & Zampieri, N., Investigation of adhesion recovery phenomenon using a scaled roller-rig. *Vehicle System Dynamics*, **59(2)**, pp. 295–312, 2021. <https://doi.org/10.1080/00423114.2019.1677922>
- [33] Bosso, N., Gugliotta, A., Magelli, M., Oresta, I. F. & Zampieri, N., Study of wheel-rail adhesion during braking maneuvers. *Procedia Structural Integrity*, **24**, pp. 680–691, 2019. <https://doi.org/10.1016/j.prostr.2020.02.060>.