

Automated IoT-Connected On-Board Fault Detection in Fan-Coils: Prototype Construction and Preliminary Testing

Original

Automated IoT-Connected On-Board Fault Detection in Fan-Coils: Prototype Construction and Preliminary Testing / Villa, Valentina; Siccardi, Stefania; Corneli, Alessandra; Piantanida, Paolo; Aliev, Khurshid. - ELETTRONICO. - (2022), pp. 1-6. (International Structural Engineering and Construction Sydney, Australia November 28 - December 02, 2022.) [10.14455/ISEC.2022.9(2).FAM-01].

Availability:

This version is available at: 11583/2973789 since: 2022-12-13T10:45:58Z

Publisher:

ISEC Press

Published

DOI:10.14455/ISEC.2022.9(2).FAM-01

Terms of use:

This article is made available under terms and conditions as specified in the corresponding bibliographic description in the repository

Publisher copyright

(Article begins on next page)

AUTOMATED IOT-CONNECTED ON-BOARD FAULT DETECTION IN FAN-COILS: PROTOTYPE CONSTRUCTION AND PRELIMINARY TESTING

VALENTINA VILLA¹, STEFANIA SICCARDI¹, ALESSANDRA CORNELI², PAOLO
PIANTANIDA¹, and KHURSHID ALIEV¹

¹*DISEG, Politecnico di Torino, Torino, Italia*

²*DICEA, Università Politecnica delle Marche, Italia*

The paper focuses on design and implementation of an IoT connected on-board automated fault detection and diagnostics prototype (AFDD) for a nonspecific fan-coil, in turn part of HVAC system and of a distributed digital collaboration framework used in Facility Management. A research on common IoT architecture and maintenance strategies has been carried out besides the theoretical development of a Fault detection diagram on all the typical faults in fan-coil units. A real fan-coil was then inspected to point out its construction details and the points to be monitored. Then it was equipped with the prototype AFDD system. All the components and sensors needed to build the AFDD prototype are commonly available. The design and implementation of automated fault detection and diagnostics (AFDD) for HVAC fan-coils systems fully exploits distributed computing for remote and smart system monitoring, anomaly detection and eventually fault diagnostics to improve maintenance management through the integration of a large number of data locally gathered by smart sensors. Experimental results on the prototype are given about some recurrent fan-coil anomalies. Local intelligence allows a quick and on-site anomaly detection & fault diagnostic, as proven by running the prototype AFDD equipped fan-coil: it could help managing and scheduling maintenance, reducing time-to-fix together with indirect and direct costs, if network connected. Feeding the network with relevant data about the anomalies extracted by the local intelligence allows sharing the information at every level, also in order to statistically rate HVAC components service life and reliability.

Keywords: Facility management, BIM, HVAC, Digital twin, Predictive maintenance.

1 INTRODUCTION

According to Guillen *et al.* (2016) the most important costs in the buildings' life cycle are the one regarding the Operation and Maintenance (O&M) phase. This is mainly due to outdated maintenance practice, based on paper documents, which doesn't allow a complete and effective communication between stakeholders and often cause a loss of information, in addition to an increase of time for finding them, according to Xiao *et al.* (2019). In this context it's important to overcome these limits in order to achieve the reduction of these costs. A help can come from the advent of new technologies that are becoming part of the construction sector recently. In these years the construction industry is undergoing an important digital revolution and the arrival of new technologies has catalyzed this process (Mannino *et al.* 2021). BIM and IoT technologies can be highlighted as the most important innovations that can be fundamental for the renovation of facility

management (FM) practice since their union can bring to the creation of a digital twin (DT) of the building. The introduction of DT in FM permits to apply predictive maintenance practice, based on assets' data monitoring and prevent failures way before their happening. Therefore, it's important to study methods that permit the integration of sensors' data in BIM model. At the base of the achievement of this goal there is the creation of an AFDD, which has gained attention in the construction industry since the great improvement of efficiency and productivity that they provide, according to Shi and O'Brien (2019). Many studies have been conducted in this sense, which tried to propose a framework for improving FM practice, based on IoT and fault detection and diagnostics (Villa *et al.* 2021, Villa *et al.* 2022). This paper will illustrate an AFDD prototype and an IoT architecture with the aim of collecting data and identify failure in a fan-coil. Besides the data gathered will be visualized within the BIM model through the use of the Cloud-based platform Autodesk Forge.

2 METHODOLOGY

In this section describes the methodology which will be applied in the case study section.

2.1 IoT Architecture

The IoT architecture created for the data acquisition is illustrated in the Figure 1 and it was created by implementing the one present in the article by Villa *et al.* (2021).

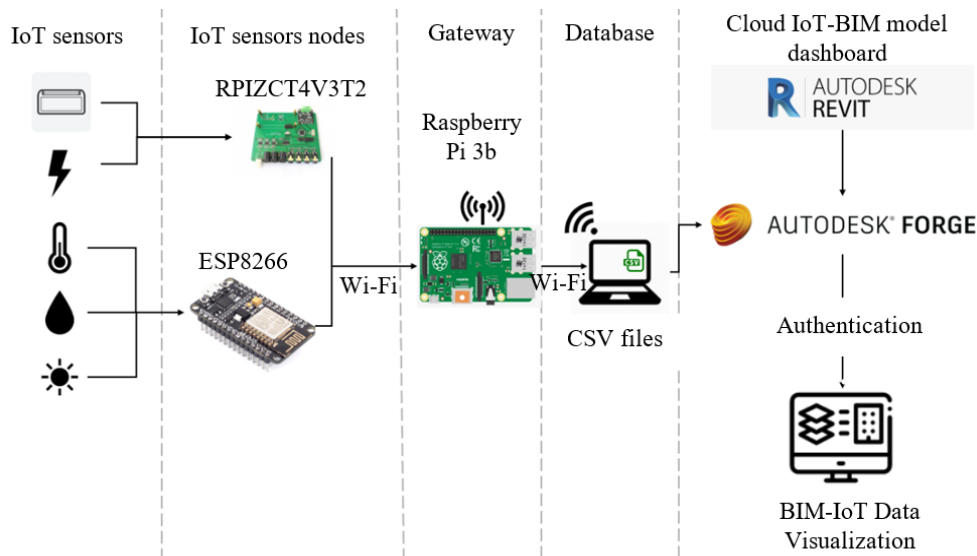

Figure 1. IoT architecture.

The IOT architecture is composed by various layers according to Khan *et al.* (2012). The first layer is the perception layer, in this case is called "IoT sensors", and it includes all the sensors used to collect data. The second layer is the network layer, in this case called "IoT sensor nodes", and it's necessary for processing and transmitting raw data coming from the sensors in order to give as output human readable data. The middleware layer is composed by the gateway, which permits the collection of data and its sending to the database, and the database itself. In this case study the database is composed by CSV file. The last layer is the application layer and consists in the use of the collected data for humans' needs. It is called, for this case study, "Cloud IoT-BIM model

dashboard” and the data collected, transmitted and processed from the previous layers, are visualized in the Autodesk Forge application, where previously the BIM model has been uploaded. Forge permits to visualize the collected data in the BIM model, associating the data to the element of the model to which they correspond to, and giving them a spatial position.

2.2 IoT System’s Components

In this case sensors were employed to monitor fan-coils condition and room’s environmental parameters. Sensors were installed in the fan-coil’s motor to monitor its current (SCT-013-000) and voltage (77DE-06-09). Also, the water and air temperature were monitored (DS18B20), both entering and exiting the fan-coil. The voltage and current sensors were connected to RPIZCT4V3T2 development Board, besides the temperature sensors were connected to Raspberry Pi Zero. Besides, a gyroscope and an accelerometer were installed to register vibration, tilt and motion regarding the motor’s case, which were connected to ESP8266 module. Environmental parameters such as humidity, temperature and luminosity were also collected. DHT22 sensor gathers humidity and temperature data and Photoresistor sensor LDR collects luminosity data. These environmental parameters are processed by ESP8266 module and with all the other data gathered are sent to the gateway Raspberry Pi 3b. The latter component represents the core of the BIM-IoT systems, since it’s a small single board computer with Wi-Fi module, that enables the communication between all the sensors and the data’s transmission to the database. Employed sensors and embed systems are provided in Table 1.

Table 1. Sensors employed and embed systems.

Building facilities	Sensors	Embed systems as sensor node	Embed IoT gateway
Room sensors	Humidity and Temperature sensor DHT22 Photoresistor sensor LDR		
Room facility Fan coil sensors	Gyroscope and accelerometer MPU6050	ESP8266 development board	Raspberry Pi 3B
Room facility Fan coil sensors	Current sensor – SCT-013-000 Voltage 77DE-06-09 Temperature DS18B20 Temperature RTD(PT100)	RPIZCT4V3T2 development Board Raspberry Pi Zero W	

2.3 Fault Detection Diagram

The selection of the sensors to be employed in the IoT architecture was made according to the identification of recurrent anomalies in fan-coils. The most common failures regard the motor, not sufficient air or water flow, obstructed filter, capacitor failure and others. Each of this failure require proper action that can be planned thanks to AFDD. An automated fault detection system was created as shown in Figure 2, based on the positioning of specific sensors. In particular, sensors were placed for monitoring the motor’s current (i1, i2, i3), motor’s voltage (v1, v2, v3), motor’s temperature RTD, water temperature (T1, T2) and air temperature (T3, T4).

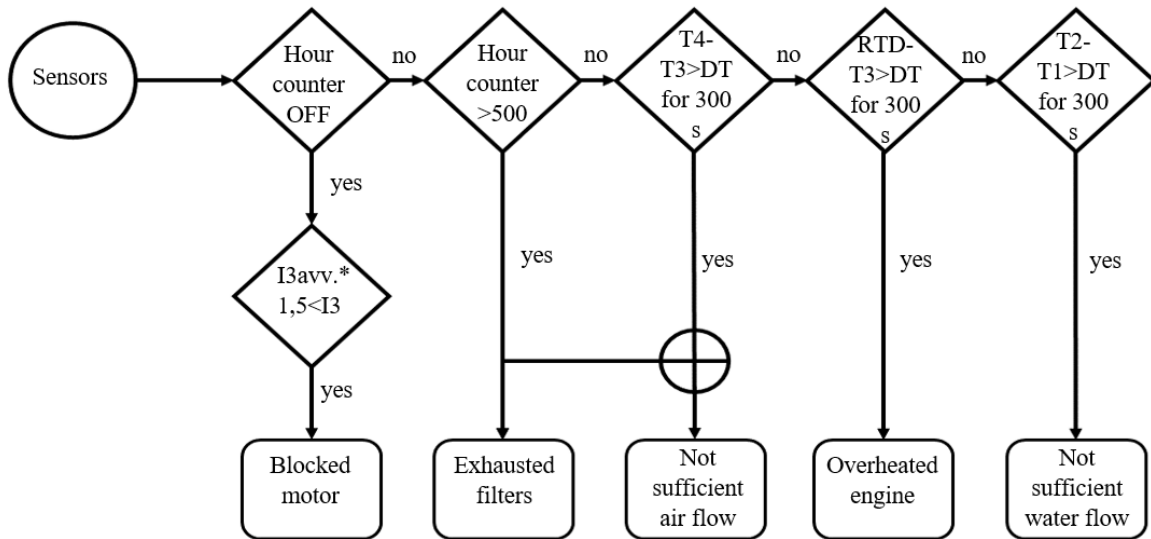

Figure 2. Fault detection system.

3 CASE STUDY

The case study is the department of structural geotechnical and building engineering (DISEG), located in Turin at the Polytechnic of Turin. The fourth floor of the department was modelled in 3D using Autodesk Revit 2022. In all the department's room are present fan-coils, which are produced by EuroMotors Italia and are type FC83M-2014/1 with 4 possible speeds. The fan-coil is equipped of cooling and heating battery and a filter that must be checked. The sensors described in the methodology section are installed in the fan-coil to monitor its behavior.

3.1 Data Integration

After the data acquisition performed in the "IoT system's components" section with the AFDD, the next step was the integration of these data within the 3D model. In order to do so, 'Autodesk Forge' was used, in particular, the Data Visualization API. A web application was created on the site of Forge, enabling all the API necessary for the Data visualization, and a Client ID and a Client Secret were provided for running the application. Successively, the installation of the Reference Application was necessary. For this purpose, the integrated development environment Visual Studio Code version 1.67.2 was used, and the language chosen was Node.js. After the reference application was installed, the default model present in it was replaced by the one of the case studies. The replacement was performed with the creation of a bucket in the application, which is an arbitrary space created by the application, used to store objects for later retrieval. After the upload in the bucket, the model can be visualized within the Forge application. Eventually the sensors' data were integrated in the model. To do so, sprites and 2D elements were placed to represent the sensors. In the device-models.js the device model with ID, name, description, type, unit, minimum range value, and maximum range value, were defined. Each device model has an associated icon and a color gradient associated to the heatmap, as visible in Figure 3. Eventually, the CSV file was imported by defining the environmental variables in the application.



Figure 3. (a) Parameter's color gradient for heatmap; (b) icon associated to each parameter.

3.2 Data Visualization

In the IDE the command “npm run dev” is given and the application is launched and can be opened through the static address <http://localhost:9000/>. The result is displayed in Figure 4. The sensor list on the right contains all the sprites that are ordered according to the levels and the rooms in which they are placed. Inside the sensors' list the graphs of the parameters through time can be viewed as shown in Figure 4. The higher part presents a timeline, which permits a selection of a specific time at which to view data.

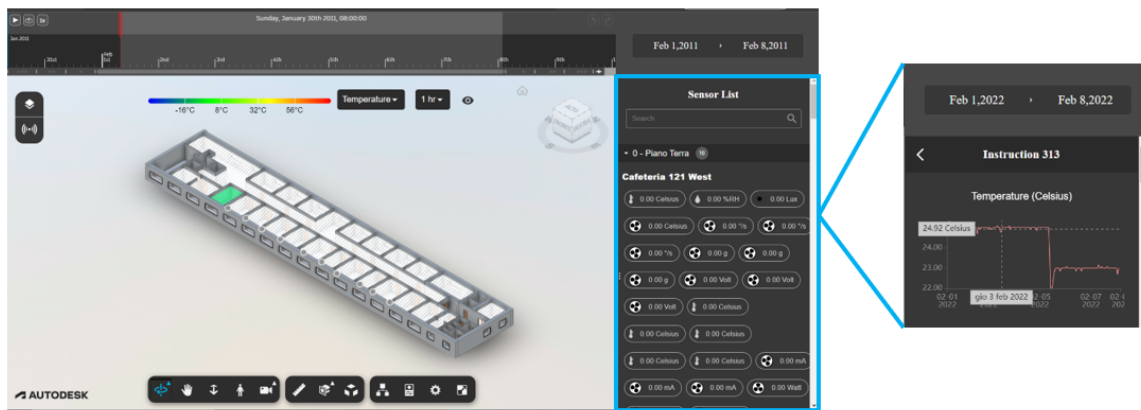

Figure 4. Sensor list categorized by levels and rooms and the graph parameter-time viewable in it.

Besides, under the timeline, the parameter's color gradient is present, which is associated with the heatmap quickly gives an insight into the conditions inside the room.

4 CONCLUSION

This study demonstrated how the use of this type of data visualization, based on AFDD, has a great potential for practical use in FM and is capable of integrating IoT sensors' data within the BIM model in order to create a DT. This can be a support for FM practice, in particular for justify decision making and predict failure through data analysis. Forge permits to combine the static information of the BIM model with the dynamic ones coming from the sensors', all in one place. The benefits that derive are many and can be summarized in:

- Spatial identification of anomalies for a focused intervention
- Data analysis for maintenance operation planning
- Anomalies detection for an immediate intervention, preventing interruption of service for public building.

Seeing as the great potential of this application some future research to pursue can be many. Primarily the availability of the Forge application from other devices since in this case can be launched only in the ones where the application is installed. This could improve the data availability and making them accessible from anywhere and in any device. A solution in this sense can be given by Azure where the application's directory could be hosted in order to make it available only having a device with an internet connection.

Acknowledgments

This research was funded by the Italian government, through the PRIN2017 project of the Ministero dell'Istruzione, dell'Università e della Ricerca (MIUR). The project entitled "Distributed Digital Collaboration Framework for Small and Medium-Sized Engineering and Construction Enterprises" is coordinated at the national level by Berardo Naticchia and is developed by the Research Unit of Politecnico di Torino with other colleagues: Dario Antonelli, Giulia Bruno.

References

- Guillen, A. J., Crespo, A., Gómez, J., González-Prida, V., Kobbacy, K., and Shariff, S., *Building Information Modeling as Assesst Management Tool*, IFAC-PapersOnLine, 49(28), 191-196, 2016.
- Khan, R., Khan, S. U., Zaheer, R., and Khan, S., *Future Internet: The Internet of Things Architecture, Possible Applications and Key Challenges*, In 2012 10th International Conference on Frontiers of Information Technology (FIT): Proceedings, Institute of Electrical and Electronics Engineers Inc., 257-260, 2012.
- Mannino, A., Dejacco, M.C. and Re Cocconi, F., *Building Information Modelling and Internet of Things Integration for Facility Management—Literature Review and Future Needs*, Applied Sciences, 11(7), 3062, 2021.
- Shi, Z., and O'Brien, W., *Development and Implementation of Automated Fault Detection and Diagnostics for Building Systems: A Review*, Automation in Construction, 104, 215-229, 2019.
- Villa, V., Bruno, G., Aliev, K., Piantanida, P., Corneli, A., and Antonelli, D., *Machine Learning Framework for the Sustainable Maintenance of Building Facilities*, Sustainability, 14(2), 681, 2022.
- Villa, V., Naticchia, B., Bruno, G., Aliev, K., Piantanida, P., and Antonelli, D., *IoT Open-Source Architecture for the Maintenance of Building Facilities*, Applied Sciences, 11(12), 5374, 2021.
- Xiao, Y.-Q., Li, S.-W., and Hu, Z.-Z., *Automatically Generating a MEP Logic Chain from Building Information Models with Identification Rules*, Applied Sciences, 9(11), 2204, 2019.