

A novel fuel injected mass feedback-control for single and multiple injections in direct injection systems for CI engines

Original

A novel fuel injected mass feedback-control for single and multiple injections in direct injection systems for CI engines / Ferrari, Alessandro; Novara, Carlo; Vento, Oscar; Violante, Massimo; Zhang, Tantan. - In: FUEL. - ISSN 0016-2361. - ELETTRONICO. - 334:2(2023). [10.1016/j.fuel.2022.126670]

Availability:

This version is available at: 11583/2973405 since: 2022-12-20T08:19:29Z

Publisher:

Elsevier

Published

DOI:10.1016/j.fuel.2022.126670

Terms of use:

This article is made available under terms and conditions as specified in the corresponding bibliographic description in the repository

Publisher copyright

Elsevier postprint/Author's Accepted Manuscript

© 2023. This manuscript version is made available under the CC-BY-NC-ND 4.0 license
<http://creativecommons.org/licenses/by-nc-nd/4.0/>. The final authenticated version is available online at:
<http://dx.doi.org/10.1016/j.fuel.2022.126670>

(Article begins on next page)

A novel fuel injected mass feedback-control for single and multiple injections in direct injection systems for CI engines

Ferrari A.^(*,a), Novara C.^(b), Vento O.^(a), Violante M.^(c), Zhang T.^(d)

^a Energy Department, Politecnico di Torino, Turin, Italy

^b Electronics and Telecommunications Department, Politecnico di Torino, Turin, Italy

^c Control and Computer Engineering Department, Politecnico di Torino, Turin, Italy

^d College of Mechanical and Vehicle Engineering, Hunan University, Changsha, China

(*) Corresponding author. Email: alessandro.ferrari@polito.it Phone +390110904426

Abstract

A new feedback-control capable to enhance the fuel injected quantity accuracy has been proposed and tested. The experimental pressure in the rail and that measured along the rail-to-injector pipe, in the vicinity of the injector inlet, have been used as input data to a home-made hydraulic model. By means of this model the pressure downstream of the gauged orifice at the interface between the rail and the rail-to-injector pipe is determined; the mass at the injector inlet can be obtained by means of an integration of the estimated flow-rate entering the injector. A robust mathematical law can be established between the mass that enters the injector and the one injected, thus, a feedback-control based on the error between the target injected quantity stored in the ECU and the predicted injected mass has been designed and implemented for the *ET* correction. The new feedback-strategy has been applied to control both single and double (pilot-main) schedules by using a rapid prototyping hardware. Regarding single shots, the new control results to be capable of reducing the injected mass inaccuracy, which is due to the different thermal regimes experienced by the injector, below 0.6 mg (the standard open loop control can feature an error up to 2 mg when the fuel tank temperature is varied), while for the pilot-main schedules it is possible to dramatically reduce the inaccuracy on the desired overall injected quantity (below 1 mg) when digital or continuous rate shaping programs are implemented.

28 **Keywords**

29 Injected mass control; fuel injection system; compression ignition engine, rapid prototyping
30 hardware; renewable diesel oil.

31 **Highlights**

- 32 - A novel feedback-control strategy for the injected quantity is built up.
- 33 - A rapid prototyping hardware is used to test the developed control.
- 34 - Single and multiple injection performance of the prototypal hardware is analyzed.

35 **Introduction**

36 In the last years, environmental protection agencies have concentrated on internal combustion engine
37 (ICE) emissions, due to their effect on environment and health [1]. For this reason, researchers have
38 been focused on this topic, looking for solutions that are capable to reduce the ICE impact on
39 environment and living beings [2, 3].

40 Nowadays, diesel engines are still playing a key-role as a power source [4] and numerous studies have
41 been developed regarding this category of engines, in which almost all the aspects are taken into
42 account. The shape of the combustion chamber, influencing the fuel-air mixing, can affect the soot
43 formation and, therefore, the smoke emissions [5]. It has been demonstrated that the consistency of
44 the engine assembly influences the NO_x emissions, for example due to a varied combustion
45 temperature leaded by the different nozzle extension height [6]. A valid approach in the reduction of
46 pollutant emissions should also consider the refinement of the after-treatment devices such as the
47 diesel oxidation catalyst, the diesel particulate filter, lean NO_x trap, and selective catalytic reduction
48 [7].

49 The Common Rail (CR) fuel injection system has added available parameters to reach an optimum
50 engine calibration for the widest range of working conditions, thanks to its increasing value of
51 maximum injection pressure, that can go beyond 3000 bar [8], the elevated number of injection events

52 for combustion cycle and the flexibility in injection timings [9]. The split ratio of a triple injection
53 strategy has been analysed to determine its effect on the ignition delay, unburned emissions, and
54 combustion noise (CN) [10]. For a HCCI engine operating with a multiple fuel shot strategy, if the
55 first injection pulse duration is increased, the diffusion phase combustion will be minimized, reducing
56 the heat release rate, thereby diminishing NO_x and soot [11].

57 Concerning to injected flow-rate pattern, it has been shown that for low and medium loads, the
58 optimum engine calibration should feature triple or quadruple injections together with possible rate
59 shaping schedules, leading to an enhancement in the soot- NO_x trade-off and a reduction in the CN
60 [12]. In particular, the digital-rate shaping strategy (the two injections are very close, but can still be
61 distinguished from one another) can improve the overall engine brake specific fuel consumption and a
62 consequent reduction in the CO_2 emissions is achieved [13]. These complex injection strategies can be
63 implemented with either a solenoid or piezoelectric injectors [17].

64 However, if the dwell time (DT) is dramatically reduced to adopt strategies such as the
65 aforementioned digital-rate shaping or the continuous rate shaping (the two injection events are
66 merged together), significant cyclic variation in the engine torque occurs, due to injector-to-injector
67 and cyclic differences regarding the rates of injections, thus representing a potential issue for the
68 engine implementation [14]. In fact, when the electric DT goes below a particular value, the overall
69 fuel injected quantity generally features anomalous increasing, hence a small change in the hydraulic
70 dwell time can lead to an important influence on the fuel injected mass [15, 16].

71 This context justifies the efforts on the development of robust feedback-control strategies for the fuel
72 injected quantity, which is usually treated by means of an open-loop approach. Indeed, in standards
73 common rail system, the injected mass is predicted, based on the duration of the electrical current
74 signal (ET) and the nominal rail pressure (p_{nom}) [18]: these two values are stored onto the ECU
75 calibration maps, defined by means of preliminary experimental campaigns and there is no feedback
76 control on the effective injected mass [19].

77 An estimation technique of the fuel injected mass has been obtained by measuring the in-cylinder
78 pressure signal [20]. An already validated predictive combustion model has been applied contrariwise.
79 The overall heat transferred by the charge to the walls over the combustion period is estimated and,
80 with the acquired in-cylinder pressure, the released net energy is derived. Finally, an estimation of the
81 injected fuel mass is obtained by calculating the chemical energy of the injected fuel.

82 The feedback strategy proposed in [21] predicts the pilot mass estimation by means of the pilot
83 misfire ratio. Misfire occurs when the pilot injected quantity is not able to burn and, consequently, an
84 increased premixed peak of the main injection combustion takes place. Since the misfire probability is
85 well correlated with the pilot mass [22], the pilot injected mass can be predicted, after a preliminary
86 characterization of the misfire events, using an in-cylinder pressure transducer applied to detect the
87 misfire. In [21], the correlation between the pilot injected mass and the pilot misfire ratio is used
88 together with a Bayesian approach.

89 Two robust feedback-control strategies have been developed for both single and pilot-main shots, by
90 means of the measurement of the flow-rate entering the injector [23, 24]. It has been shown that the
91 mass entering the injector, obtained through an integration of the measured flow-rate, correlates well
92 with the effective injected quantity. Hence, a feedback-control to modify the energizing time (*ET*) to
93 the injector pilot stage has been established, and the current signal is modified based on the error
94 between the predicted injected mass and the target one.

95 Another technique to estimate the mass entering the injector is based on an artificial neural network
96 [25]. In this case, the input signal is represented by the pressure time distribution measured in the
97 vicinity of the injector inlet.

98 A prediction of the injection temporal length (*ITL*) has been obtained by means of an approach
99 involving the time-frequency analysis [26]. The short-time Fourier transform is applied to the pressure
100 trace measured in the proximity of injector inlet, then the mean instantaneous frequency (*MIF*) trace
101 is determined and is used to develop a needle-lift virtual sensor. The injected mass can be estimated

102 by means of the *ITL* prediction, that is given by the distance between two local maximums of the *MIF*
103 trace.

104 Compensative strategies for the injected mass have been introduced by injection systems
105 manufacturers, which have produced superior injectors featuring additional devices to mitigate the
106 inaccuracy of the fuel injected quantity. Bosch developed an injector equipped with a force transducer
107 (labelled as Needle Closing Sensors), that acquires the pressure force induced by the fuel inside the
108 control chamber. Some noteworthy instants regarding the needle motion can be recognized by means
109 of this force time history and they are used as input data to an algorithm which estimates the injected
110 fuel quantity [27]. The i-Art technology designed by DENSO is able to measure the pressure in the
111 control chamber by means of a piezoelectric pressure sensor installed to the injector pilot stage. This
112 pressure signal is used to predict the injected mass with a complex transfer function [28, 29]. Finally,
113 Delphy has proposed the “Switch” technology. The non-ballistic needle is inserted inside an electric
114 circuit where the voltage is detected. When the needle closes the nozzle, or it reaches its upper stroke
115 end the circuit closes in two distinct manners. Therefore, if the voltage is detected, the two
116 corresponding time instants can be identified, and the injected quantity can be estimated by means of
117 a needle lift-based submodel [30].

118 In this work, an innovative feedback-control strategy to reduce the inaccuracy of the fuel injected
119 quantity is presented and tested. The proposed algorithm receives as input datum the measurement of
120 the pressure traces inside the rail and along the pipe that feeds the injector, in the vicinity of the
121 injector inlet. The mass which enters the injector can be estimated based on these pressure signals
122 and, by means of a correlation, the predicted injected mass is obtained. The new feedback-control has
123 been implemented in a rapid prototyping hardware. Different fuel tank temperatures have been taken
124 into account to analyse single injections, while for pilot-main shots the total injected mass has been
125 measured in the short *DT* range. The new strategy represents an evolution of that developed in [23,
126 24] because the installation of only one additional pressure transducer is required in the commercial
127 *CR* injection system layout.

128

129 **Experimental facility**

130 The hydraulic tests have been performed at the Politecnico di Torino ICE Laboratory, at a Moehwald-
131 Bosch hydraulic test bench (nominal power: 35 kW, maximum speed: 6100 rpm, maximum torque:
132 100 Nm). Different thermocouples and piezoresistive pressure transducers are used to monitor the
133 temperature and the pressure levels in various locations of the analysed high-pressure hydraulic
134 circuit. A HDA flowmeter [31] measures the injected flow-rate traces that are integrated to obtain the
135 corresponding masses, while injector fuel leakages are evaluated by means of a KMM flowmeter.

136 The adopted calibration fluid at the test rig is a Shell V-Oil 1404 (ISO 4113), since it is capable to
137 satisfactorily reproduce the renewable diesel oil properties over a proper range of pressure and
138 temperature values (at least up to 120°C).

139 The selected injection system for the experimental campaign is a last generation Bosch CR system.
140 The rail (with a capacitance of 10 cm³) is fed by a high-pressure pump featuring a displacement of
141 430 mm³ with a double effect single piston and a transmission ratio with the engine equals to 1:1.
142 Four CRI 2.20 (solenoid-actuated) injectors are connected to the rail by means of high-pressure pipes
143 with a length of 320 mm and an internal diameter of 2.8 mm.”

144 The injector pilot stages feature a pressure-balanced pilot-valve. Moreover, they present an integrated
145 Minirail. Figure 1 presents the scheme of the tested injector.

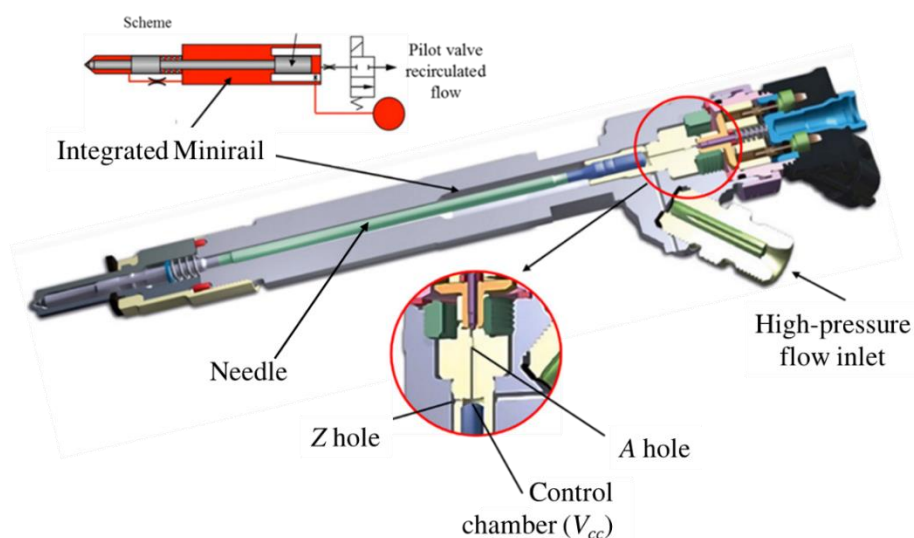

146

147

Figure 1. Injector CRI 2.20.

148 Concerning the injector working principle, a part of fuel entering the injector from the injector-
149 feeding pipe fills, through the Z hole, the control chamber (volume V_{cc}), and the other part reaches the
150 integrated Minirail. The injection starts after the electronic control unit (ECU) has switched on the
151 electrical current I to the pilot valve solenoid. Consequently, the control chamber is discharged
152 through the A hole and the needle moves up opening the nozzle. The control chamber pressure starts
153 again to rise at the end of the current signal provided by the ECU , and the needle closure phase is
154 induced. The hydraulic end of the injection is achieved when the needle closes the nozzle reaching its
155 downstroke end [32].

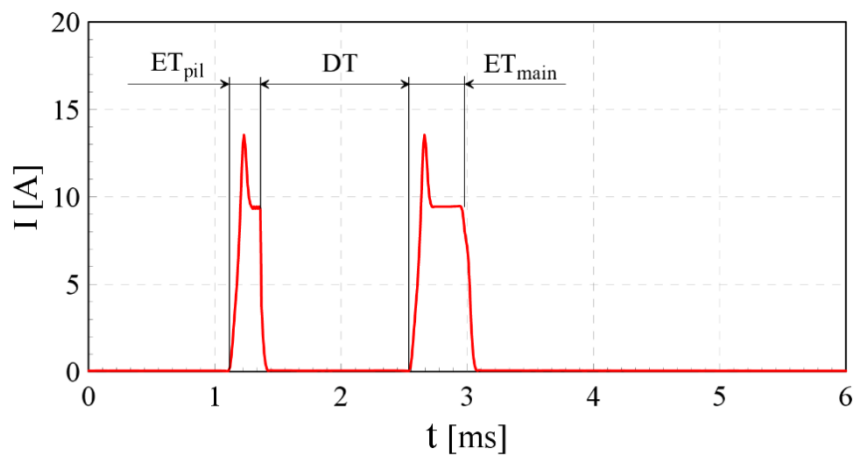

156

157 *Figure 2. Example of a pilot-main injection current signal.*

158 Both single and pilot-main injections have been taken into account and the considered nominal rail
159 pressure levels (p_{nom}) varied in the range 500-1800 bar. Tests on single injections have been
160 performed by considering different ET values. Regarding the pilot-main injections, different
161 combination of ET_{pil} , ET_{main} and DT have been selected, and their meaning is shown in Fig. 2.
162 Pertaining to pilot-main injections, different rail pressure levels have been selected and, for each of
163 them, the same main and pilot injected quantities have been chosen: 15 mg, 20 mg or 30 mg for the
164 main injection and 1.5 mg or 3 mg for the pilot injection. The dwell time has been varied from 100 μ s
165 to 500 μ s.

166 The selected pump speed for the entire experimental campaign was 2000 rpm, corresponding to 2000
167 rpm of engine speed.

168

169 **Algorithm of the feedback-control and rapid prototyping hardware**

170 Figure 3 shows the injection system layout. A pressure sensor mounted at one rail extremity is used to
 171 monitor the rail pressure time history $p_{rail}(t)$. The nominal rail pressure control strategy and the one
 172 pertaining to the modulation of the ET to the injector have been developed on Matlab Simulink.

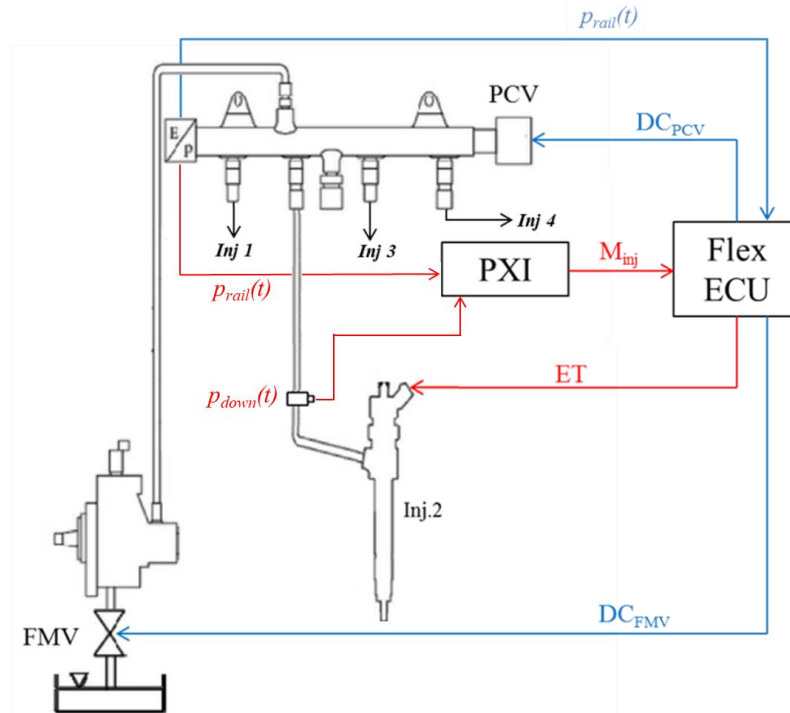

173

174 *Figure 3. The layout of the tested injection system (blue refers to p_{rail} control system and red to M_{inj} control system).*

175 Opposite the rail pressure sensor, the pressure control valve (PCV) is installed (cf. Fig 3). This valve
 176 is employed to control and maintain the nominal rail pressure p_{nom} target (provided by the ECU). A
 177 closed-loop control is set up by monitoring $p_{rail}(t)$, throttling the excess of the pumped fuel. The rail
 178 pressure can also be controlled through the fuel-metering valve (FMV) that is installed at the pump
 179 inlet. By acting on the FMV , the flow-rate entering the pump is modified based on the injector
 180 requirements and the flow-rate throttled by the PCV is ideally null [33].

181 A scheme of the implemented injection system control strategies is reported in Fig. 4. The rail
 182 pressure signal is acquired with a frequency of 200 Hz by the ECU , giving the filtered signal $p_{filter}(t)$
 183 (block H2). The difference $e(t)$ between p_{nom} and $p_{filter}(t)$ is computed and is received as an input by
 184 block R2, where the PID controller for the rail pressure is usually implemented in commercial

185 systems. This controller generates the duty cycle value to be provided to the valve selected for the
 186 pressure control (FMV or PCV).

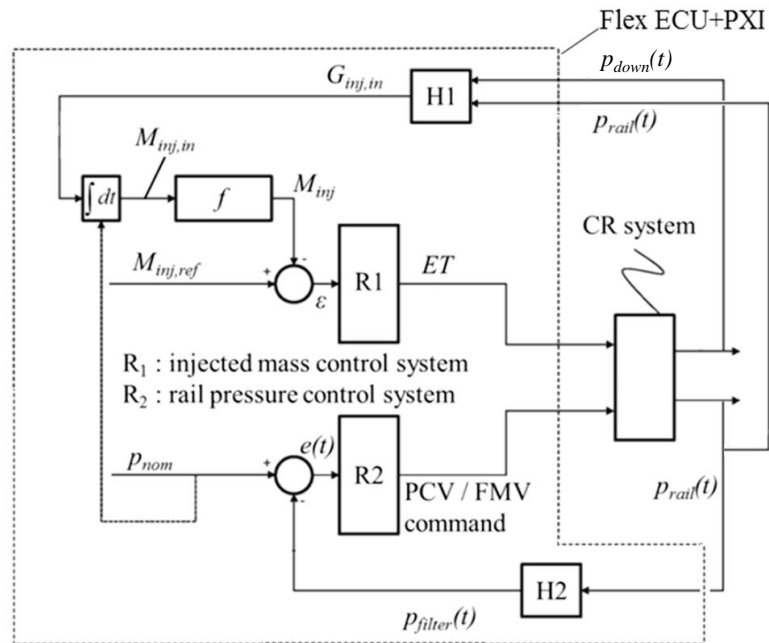

187

188

Figure 4. The injection system control strategies.



189

190

Figure 5. Scheme of the hydraulic model.

191 The new control strategy shown in Fig. 4 consists in the injected mass feedback-control and the
 192 installed hardware has been simplified compared to that installed in [23, 24]. The measured pressure
 193 signals $p_{down}(t)$ (acquired near the injector inlet, cf. Fig. 3) and $p_{rail}(t)$ are sufficient to determine the
 194 mass flow-rate time history entering the injector. Unlike the prototype in [23, 24], as is shown in Fig.
 195 3, it is therefore enough to install only one pressure sensor along the injector-feeding pipe.

196 In block H1 (cf. Fig. 4), which receives $p_{rail}(t)$ and $p_{down}(t)$ as input (acquired with a frequency of 30
 197 kHz, that is much higher than the standard sampling frequency used in the H2 block for the rail
 198 pressure control), a simple hydraulic model is implemented. In this model, represented in Fig. 5, the
 199 rail is assumed as a zero-dimensional chamber at which the measured pressure $p_{rail}(t)$ is imposed as a

200 boundary condition. The rail is connected to the injector-feeding pipe by means of a gauged orifice
 201 (its used in the commercial layout as a passive damper for the free pressure waves triggered by the
 202 nozzle closure [34]), characterized by a restricted area A_{res} (obtained by measuring the gauged orifice
 203 diameter, equals to $d_{res}=1$ mm) and a flow coefficient $C_d=0.8$ (this value has been fitted on flow-rates
 204 values at the injector inlet obtained by applying other techniques presented in [23, 24]). Close to the
 205 downstream extremity of the high-pressure pipe with cross-section area A , the measured pressure time
 206 history $p_{down}(t)$ is assigned as the second boundary condition at a distance L from the orifice outlet.
 207 The pressure $p_{up}(t)$ represents the pressure trace measured at the inlet of the injector-feeding pipe (cf.
 208 Fig 5) and is an unknown quantity. The instantaneous flow-rate G_{or} flowing through the gauged
 209 orifice can be expressed as:

$$210 \quad \begin{cases} G_{or} = -C_d \cdot A_{res} \cdot \sqrt{2 \cdot (p_{up} - p_{rail})\rho} & \text{if } p_{up} > p_{rail} \\ G_{or} = C_d \cdot A_{res} \cdot \sqrt{2 \cdot (p_{rail} - p_{up})\rho} & \text{if } p_{rail} > p_{up} \end{cases} \quad (1)$$

211 where ρ represents the flow density.

212 The continuity equation and the momentum balance equation for the piece of pipe with length L have
 213 been combined. By neglecting the wall shear stress and with the assumption of 1D incompressible
 214 flow, one obtains

$$215 \quad \frac{\partial u}{\partial t} + \frac{1}{\rho} \frac{\partial p}{\partial x} = 0 \quad (2)$$

216 where u and p stand for the 1D velocity and pressure, respectively, and x represents the spatial
 217 coordinate along the pipe axis.

218 Multiplying Eq. (2) by ρA (ρ is the flow density), integrating over the distance L and dividing by the
 219 same distance L , on has:

$$220 \quad \frac{d\bar{G}}{dt} = \frac{A}{L} (p_{up} - p_{down}) \quad (3)$$

221 where \bar{G} represents the space-averaged instantaneous flow-rate. By integrating Eq. (3) with respect to
 222 the time, one obtains:

$$223 \quad \bar{G} = \int_0^t \frac{A}{L} \cdot (p_{up} - p_{down}) dt \quad (4)$$

224 It can be assumed that $G_{or} \approx \bar{G}$ [35]. Eqs. (1) and (4) can therefore be solved together and the two
 225 unknown variables, namely the pressure p_{up} and the flow-rate G_{or} traces, can be evaluated.

226 The flow-rate that reaches the injector is evaluated by means of [23, 24]:

$$227 \quad G_{inj,in} = \frac{A}{L} \int_0^t \Delta p dt - \frac{A}{L} \langle \Delta p \rangle \cdot t \quad (5)$$

228 where $\Delta p = p_{up} - p_{down}$ and $\langle \Delta p \rangle$ stands for the Δp time-averaged value for the considered
 229 injection cycle. This flow-rate represents the output of block H1 (cf. Fig. 4) and by integrating it over
 230 time instants t_i and t_f , the injector inlet mass $M_{inj,in}$ is obtained:

$$231 \quad M_{inj,in} = \int_{t_i}^{t_f} G_{inj,in} dt \quad (6)$$

232 In Fig. 6, two different flow-rates for single and double injection are represented. The integration
 233 performed in Eq. 6 to obtain $M_{inj,in}$ starts in correspondence of the time instant at which the electrical
 234 current begins to rise (in Fig. 6 one has $t_i = 0$), and it stops at the time instant where the $G_{inj,in}(t)$ trace
 235 features its absolute maximum [23, 24]. The negative flow-rates that can be inferred in Fig. 6 are due
 236 to the pressure waves travelling back and forth along the pipe that feeds the injector, which are caused
 237 by the nozzle closure. These physical contributions are not taken into account since they occur after t_f .

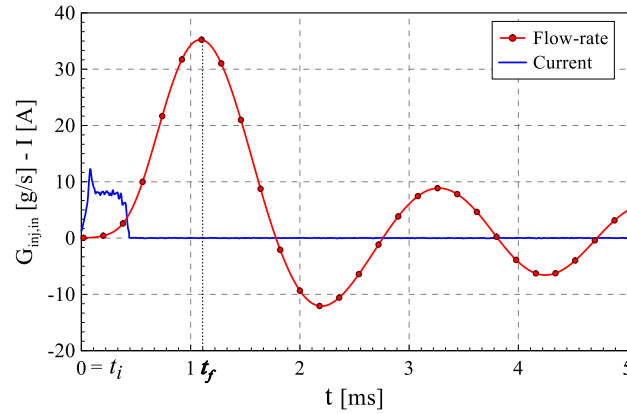

238
 239

(a): Single injection ($p_{nom} = 1200$ bar, $M_{inj,ref} = 20$ mg).

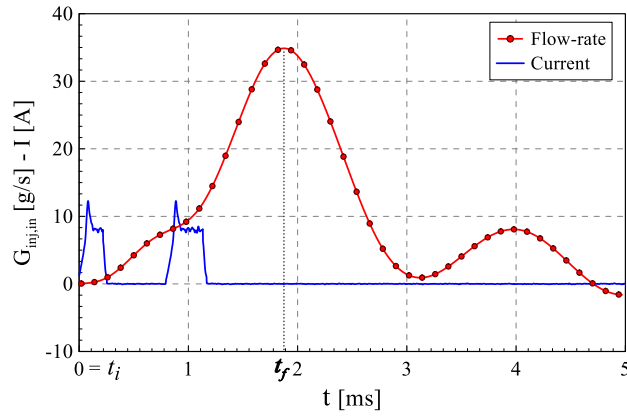

(b): Pilot-main injection ($p_{nom} = 1600$ bar, $M_{inj,pil} = 3$ mg, $M_{inj,main} = 30$ mg, $DT = 500$ μ s)

Figure 6. Flow-rates time histories entering the injector for a single (a) and a pilot-main (b) injection.

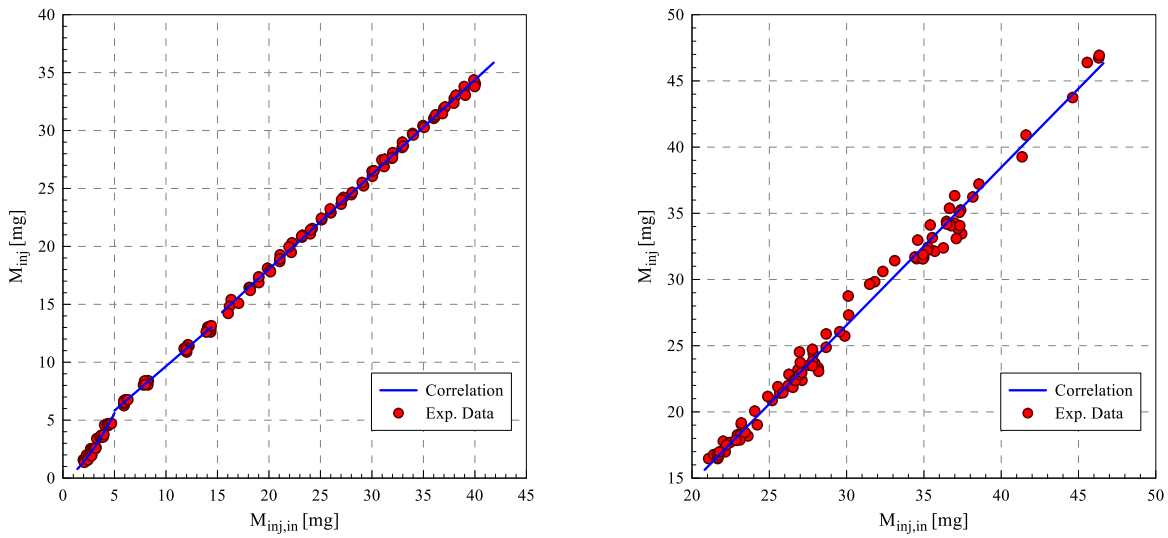

(a): Single injections.

(b): Pilot-main injections

Figure 7. Mathematical laws to determine the injected fuel quantity from the injector inlet one.

Figure 7 shows that the fuel injected quantity (M_{inj}) correlates well with the fuel amount that enters the injector ($M_{inj,in}$). This is verified for both single (cf. Fig. 7a) and pilot-main injections (cf. Fig. 7b), where the M_{inj} data refer to the overall injected quantities during the different injection events). Mathematical laws, namely $M_{inj}=f(M_{inj,in})$, reported in Fig. 7 have been obtained by means of a fitting of the experimental points (126 for single injections and 90 for pilot-main schedules, both referring to different rail pressure levels and injected masses). Thanks to these correlations the measurement of $M_{inj,in}$ allows the estimation of M_{inj} during the real system operation. Furthermore, the presented correlations result to be independent with respect to the fuel tank temperature (T_{tank}) [23, 24]. Quantity ε is calculated by subtracting the prediction of the injected amount M_{inj} to the desired target value ($M_{inj,ref}$), stored in the ECU, This difference reaches, as an input, block R1 (cf. Fig. 4), which contains

256 a *PID* controller that calculates the corrected *ET* that can mitigate the inaccuracy of the fuel injected
257 quantity for the next injection event. In Fig. 3, the hardware components employed for the new
258 control strategy are represented. A National Instrument PXI platform has been used to receive the
259 signals from the sensors of p_{rail} and p_{down} and to implement Eqs. (1), (4)-(6) and the mathematical laws
260 given by $M_{inj}=f(M_{inj,in})$. A CAN interface cable is used to deliver the injected mass prediction from the
261 PXI platform to the ETAS Flexible ECU, which generates the energizing time to the injectors.
262 A *ECU* software is usually split into two parts: the first, generally provided by the injection system
263 manufacturer, is the basic software, which contains all the basic information (e.g., the instructions to
264 connect the different pins with the injection system actuators) and the second, called application
265 software, contains the control strategies, such as the pressure and the *ET* ones. ETAS EHOOKS
266 software is used to merge the two aforementioned software and to provide a single software that is
267 finally flashed in the Flexible ECU.

268

269 **Results and discussion**

270 For a selected working condition, in terms of different values of nominal pressure and target
271 injected mass, the HDA flowmeter has measured the effectively injected fuel quantity (M_{inj})
272 averaged over 100 consecutive engine cycles. Two different fuel tank temperatures have been
273 selected: 40°C, which is usually selected as reference value from the injection system
274 suppliers, and 68°C, that represents the maximum temperature available in the test bench, for
275 safety reasons.

276 To assess the injected mass accuracy of the fuel injection system, one can introduce the
277 accuracy $|\Delta M_{inj}|$, given by the absolute value of the difference between the effective-injected
278 mass and the target value. This accuracy is represented along the vertical axis of the 3D
279 diagrams in Figs. 8a, 8b and 8c with respect to both p_{nom} and $M_{inj,ref}$ for single injections. In
280 particular, Figs. 8a, 8b and 8c all refer to the fuel tank temperature $T_{tank}= 40^\circ\text{C}$ and they plot
281 data for the standard system with the standard open-loop technique used to control the

282 injected mass (cf. Fig. 8a), for the previously developed [23] system featuring the closed-loop
 283 strategy in which two pressure sensors are involved (cf. Fig. 8b), and for the new system,
 284 where the closed-loop control requires only one pressure signal measured along the injector-
 285 feeding pipe (cf. Fig. 8c). For all the systems, the pressure is *FMV* controlled based on the
 286 difference between p_{nom} and p_{filt} . In Fig. 8, the system with one pressure sensor features
 287 similar performance as that of the layout with two additional pressure sensors and its
 288 accuracy, which is generally lower than 0.6 mg, slightly improves that of the standard
 289 apparatus.

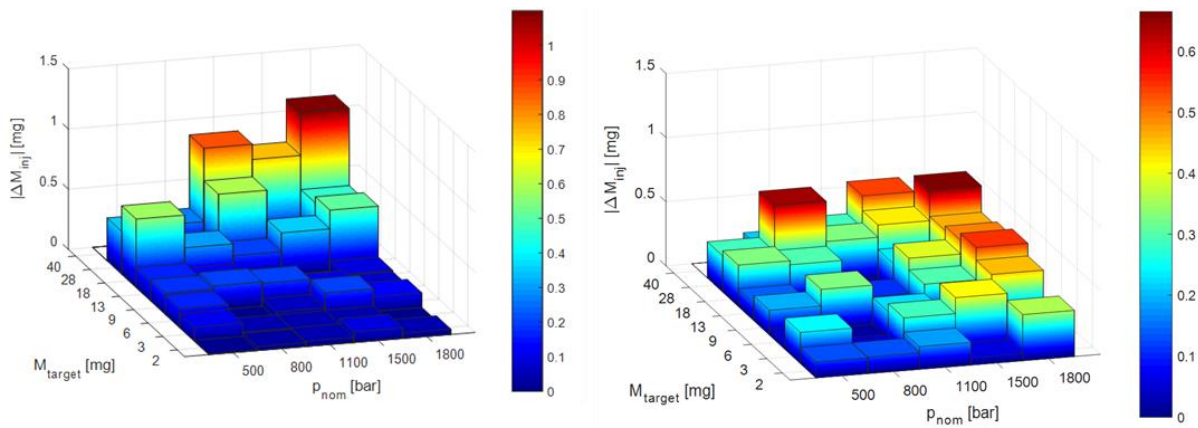

290

291

(a): Standard control strategy.

(b): Control strategy with two pressure sensors.

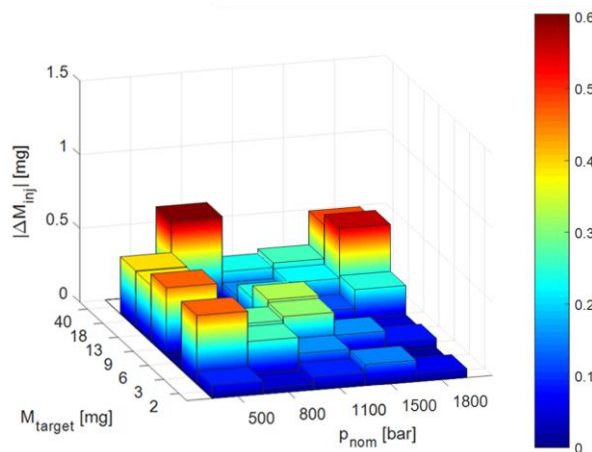

292

293

(c): Control strategy with one pressure sensor.

294

Figure 8. Control strategies performance at $T_{tank} = 40^{\circ}\text{C}$.

295 The advantages of the feedback-control strategy for the injected quantity become obvious as

296 T_{tank} increases, as reported in Fig. 9, where $T_{tank}=68^{\circ}\text{C}$. In this case, the standard injection

297 system (open-loop control for the injected mass) features an inaccuracy of the injected mass
298 of around 1.5-2.2 mg for significant target mass and high p_{nom} level, as shown in Fig. 9a,
299 while when the new closed-loop control acts the error is below 0.9 mg within the entire range
300 of working condition (cf. Fig. 9c). Furthermore, the performance is in line with that in Fig.
301 9b, where the results of the two additional pressure sensors technique are represented. The
302 fuel temperature affects the injector internal dynamic and modifies the injected quantity for a
303 certain set of ET and p_{nom} , since the ET -based injector characteristic is temperature dependent
304 [26]. This is evident from the comparison of Figs. 8a and 9a: the standard injection system
305 has the best performance when the T_{tank} value is set to the one at which the standard open-
306 loop control strategy has been tuned, while the accuracy worsens when the fuel temperature
307 augments.

308 Referring to the new control strategy (cf. Figs. 8c and 9c), the inaccuracy is mainly related to
309 the error in the injected mass prediction given by the $M_{inj,in}-M_{inj}$ correlation (cf. Fig. 7a,
310 where all the experimental data are inside a band of ± 1 mg of error), while the augment of
311 injected mass lead by the increased fuel temperature can be efficiently contrasted.

312 The normalized standard deviation pertaining to the fuel injected quantity is plotted in the
313 vertical axis of the 3D diagram in Fig. 10 (σ is normalized with respect to the average value
314 of the injected mass and is expressed as a percentage) is reported for the three different
315 control strategies. The standard deviation has been evaluated by means of the HDA over 100

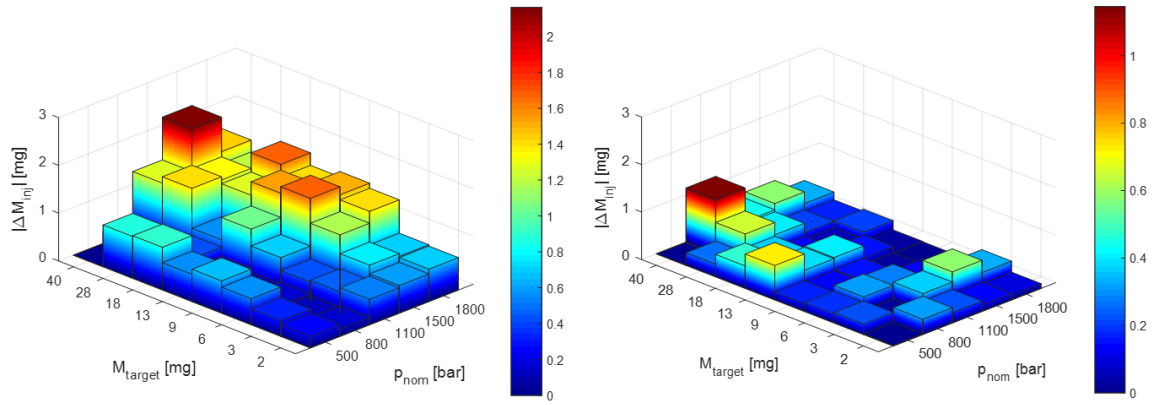

316

317

(a): Standard control strategy.

(b): Control strategy with two pressure sensors.

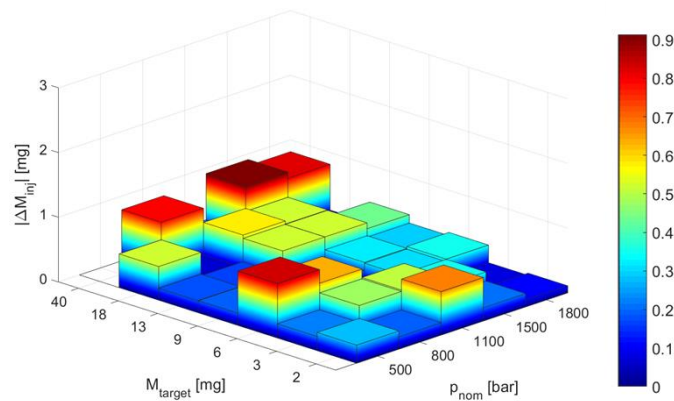

318

319

(c): Control strategy with one pressure sensor.

320

Figure 9. Control strategies performance at $T_{tank} = 68^\circ\text{C}$.

321 consecutive injections, for different single injection schedules (in terms of ET , p_{nom} and T_{tank}).

322 The severe manufacturing tolerances adopted for the CRI 2.20 injector and its Minirail are

323 capable to keep the injection stable, reaching a very satisfactory precision. Regarding the new

324 feedback-control, the precision slightly worsens with respect to the

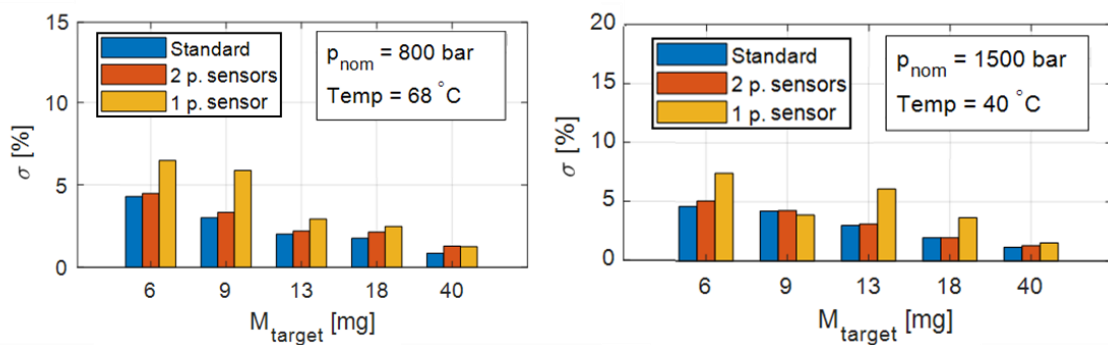

325

326

Figure 10. Injected mass normalized standard deviation for different p_{nom} and T_{tank} conditions.

327 control presented in [23]. However, it must be considered that the purpose of the proposed
328 strategy is aimed at improving the accuracy of the injection system, which can deteriorate,
329 due to physical drifts (such as the thermal one), rather than at enhancing the precision, which
330 affects the small injected masses to a great extent.

331 Concerning the pilot-main injection, dwell time sweeps have been performed. Figure 11
332 reports the pattern of the overall injected mass as DT varies for different M_{pil} , M_{main} (the pilot
333 and the main injected masses, respectively) and p_{nom} conditions when the injector is
334 controlled by means of the standard open-loop strategy (continuous curves with circle
335 symbols) and the new control-strategy (continuous curves with triangle symbols), compared
336 with the target value (dash dot lines), which is given by the sum of the pilot and main
337 nominal masses. The overall injected mass value is given by summing average values of M_{pil}
338 and M_{main} over 100 consecutive cycles measured by the HDA flowmeter. As can be observed,
339 the standard injection system cannot achieve satisfactory accuracy below $DT=300 \mu s$, hence
340 the possibility of applying efficient digital or continuous rate shaping is strongly limited [24].
341 On the contrary, the new injection system features lower accuracy than 1 mg over the entire
342 $100 \mu s \div 400 \mu s$ DT range.

343 Finally, Fig. 12 shows a dynamic test regarding a pilot-main injection with a target pilot mass
344 (M_{pil}) equals to 2 mg, a target pilot mass (M_{main}) equals to 20 mg, a dwell time of $100 \mu s$, at a
345 nominal pressure of 1000 bar and $T_{tank}= 40 \text{ }^\circ\text{C}$. Fig. 12a reports the overall injected mass
346 measured for 150 consecutive injections by the HDA (continuous line), compared with the
347 target value (dash-dot line). In the left part of the graph, where the standard open-loop
348 strategy is acting, the error on the total injected mass is around 15 mg (an injection fusion
349 event is considered). When the new control-strategy is switched on (around injection no. 50),
350 after a quick transient, the instantaneous injected mass approaches the target value, leading to
351 a dramatic reduction in the error. Figs. 12b and 12c show two different instantaneous injected

352 flow-rate traces pertaining to the standard control strategy (injection no. 25) and to the new
 353 closed-loop control strategy (injection no. 102), respectively.

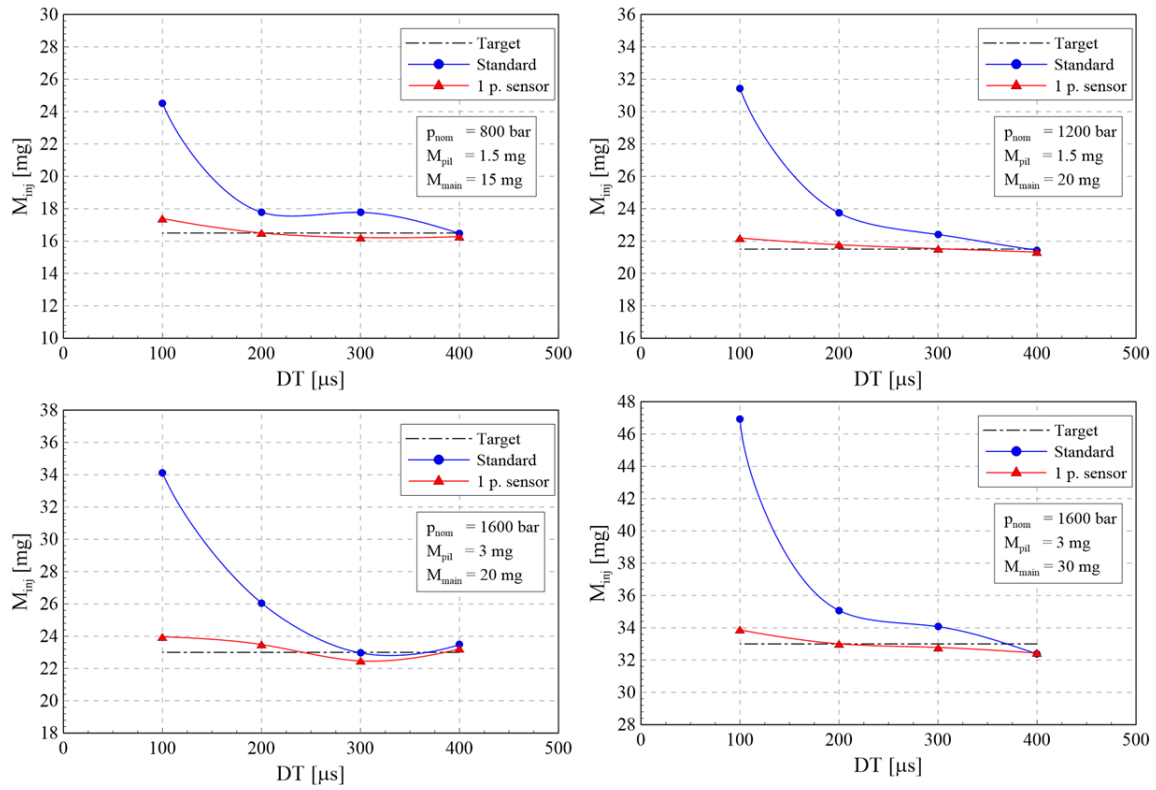

354

355

Figure 11. Performance of the new control strategy for pilot-main injections.

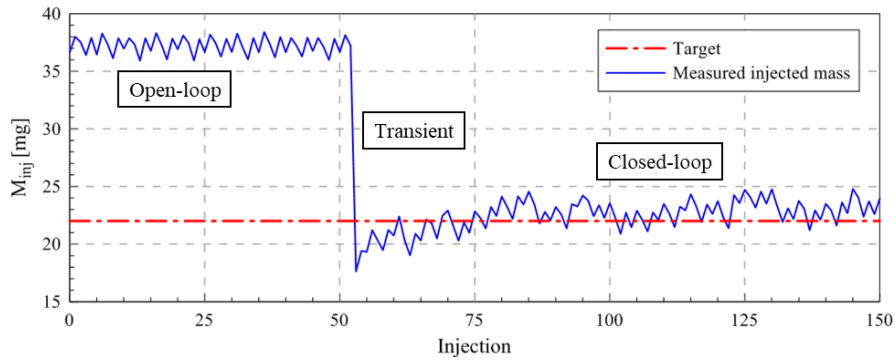

356

357

(a): Overall injected mass for 150 consecutive injections.

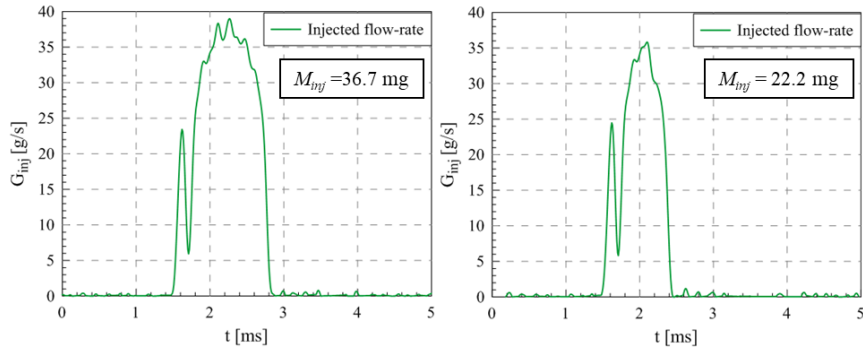

358

359

(b): Injected flow-rate time history (standard control).

(c): Injected flow-rate time history (closed-loop control).

360

361

Figure 12. Feedback-control activation effect on the injected flow-rate ($M_{inj,pi} = 2$ mg, $M_{inj,main} = 20$ mg, $DT = 100$ μ s, $p_{nom} = 1000$ bar, $T_{tank} = 40$ $^{\circ}$ C)

362

Conclusion

363

A new algorithm has been developed to calculate the flow-rate that enters the injector, based

364

on two measured pressure traces: the one inside the rail (on which the rail pressure level in

365

the commercial CR system is based) and the one detected along the injector-feeding pipe, in

366

the proximity of the injector inlet. The developed algorithm for the flow-rate calculation is

367

based on a simple hydraulic model. The rail is modelled as a zero-dimensional chamber, in

368

which the corresponding measured p_{rail} time history is imposed, and this chamber is

369

connected to the injector-feeding pipe by means of a gauged orifice, with specified area and

370

discharge coefficient. The other measured pressure signal is p_{down} , imposed as the second

371

boundary condition. The momentum balance and the continuity equations are solved in

372

conjunction with a steady-state relation and this set of equations gives as outcomes the flow-

373

rate across the orifice and the pressure time history at the orifice exit, namely p_{up} . This

374

pressure signal is used, together with p_{down} to determine the flow-rate trace entering the

375

injector, i.e. $G_{inj,in}$. By integrating $G_{inj,in}$ with respect to time, the mass at the injector inlet is

376

obtained. This mass correlates well with the effective fuel injected quantity, hence two

377

mathematical laws $M_{inj} = f(M_{inj,in})$ (one for single injections and one for pilot-main shots) have

378

been determined. Owing to this correlation, by measuring the mass that enters the injector,

379

one can obtain an estimated value of the real injected mass. A PID controller receives, as

380 input datum, the error $\Delta M_{inj} = M_{inj} - M_{inj,ref}$, and, based on it, a corrected value of the energizing
381 time acting on the injector is determined, to mitigate the injected quantity inaccuracy.

382 The presented control strategy has been tested by means of a rapid prototyping hardware
383 consisting on a Flexible ECU and a PXI platform. The software flashed into the ECU has
384 been obtained by means of ETAS EHOOKS, which merges application and basic software.

385 Experimental tests have been carried out with a passenger car Common Rail injection system
386 equipped with solenoid CRI 2.20 injectors of latest generation and both single and pilot-main
387 schedules have been considered. The performance of the newly designed closed-loop control
388 strategy has been compared with a previously developed control, in which two pressure
389 signals were measured along the pipe feeding the injector to measure the mass at the injector
390 inlet.

391 The results on single injections showed that the new control strategy is capable of reducing
392 the error in the injected quantity below 0.6 mg for all the considered working condition. The
393 control system is capable of compensating the drift, due to the different thermal regime
394 experienced by the injector. If the fuel tank temperature is varied from 40 °C to 68 °C an
395 error in the injected mass up to 2 mg can be noticed for the standard system, while the new
396 closed-loop control features an accuracy below 1 mg, in line with the previously developed
397 closed-loop control applying two additional pressure sensors.

398 Regarding the precision, the new control strategy is not capable to give any appreciable
399 benefits since the CRI 2.20 injection apparatus features high performance in terms of
400 repeatability, even when is equipped with the standard control.

401 Finally, tests on pilot-main shots have shown the capability of the presented control to
402 dramatically reduce the overall injected mass error when the two injection events are close to
403 be fused. The DT sweeps, for fixed set of p_{nom} , M_{pil} and M_{main} values, present an error in the
404 overall injected mass which is always below 1 mg.

405 In summary, the innovative architecture reaches the same control performance as in the case
406 of a previous prototype with two additional high-pressure transducers, but with significantly
407 lower manufacturing costs.

408 REFERENCES

409 [1] Nieder, R., Benbi, D.K., Reichl, F.X., 2018. Soil-borne Particles and Their Impact on
410 Environment and Human Health. *Soil Components and Human Health*. Springer, pp. 99–177.

411 [2] Nanthagopal K, Ashok B, Garnepudi RS, Tarun KR, Dhinesh B. Investigation on diethyl ether as
412 an additive with Calophyllum Inophyllum biodiesel for CI engine application. *Energy Convers
413 Manage* 2019;179:104–13.

414 [3] Dhinesh B, Annamalai M, Lalvani IJ, Annamalai K. Studies on the influence of combustion bowl
415 modification for the operation of Cymbopogon flexuosus biofuel based diesel blends in a DI diesel
416 engine. *Appl Therm Eng* 2017;112:627–37.

417 [4] Zhao, Weihua, Junhao Yan, Suya Gao, Timothy H. Lee and Xiang-rong Li. “The combustion and
418 emission characteristics of a common-rail diesel engine fueled with diesel, propanol, and pentanol
419 blends under low intake pressures.” *Fuel* (2022), vol. 307, 121692.

420 [5] Funayama, Y., Yoshitomi, K., Ishii, M., Nakajima, H. et al., "Influence of Combustion Chamber
421 Shape and In-Cylinder Density on Soot Formation in Diesel Combustion," *SAE Int. J. Adv. & Curr.
422 Prac. in Mobility* 2(1):415-425, 2020, <https://doi.org/10.4271/2019-01-2271>.

423 [6] Yan, Wei, Teng Dou, Jinbo Wang, Nanxuan Mei and Guoxiang Li. “Research on the Influence of
424 Euro VI Diesel Engine Assembly Consistency on NOx Emissions.” *Energies* 13 (2020): 5335.

425 [7] Ayodhya, Archit S. and Kumar Gottkere Narayanappa. “An overview of after-treatment systems
426 for diesel engines.” *Environmental Science and Pollution Research* 25 (2018): 35034-35047.

- 427 [8] Zhao, J., Grekhov, L. & Yue, P. Limit of Fuel Injection Rate in the Common Rail System under
428 Ultra-High Pressures. *Int.J Automot. Technol.* **21**, 649–656 (2020). [https://doi.org/10.1007/s12239-](https://doi.org/10.1007/s12239-020-0062-3)
429 [020-0062-3](https://doi.org/10.1007/s12239-020-0062-3)
- 430 [9] Payri R, Gimeno J, Martí-Aldaraví P, Viera A. Measurements of the mass allocation for multiple
431 injection strategies using the rate of injection and momentum flux signals. *International Journal of*
432 *Engine Research.* 2021;22(4):1180-1195. doi:[10.1177/1468087419894854](https://doi.org/10.1177/1468087419894854)
- 433 [10] Park, W., Ra, Y., Kurtz, E., Willems, W. et al., "Use of Multiple Injection Strategies to Reduce
434 Emission and Noise in Low Temperature Diesel Combustion," SAE Technical Paper 2015-01-0831,
435 2015, doi:10.4271/2015-01-0831.
- 436 [11] Venkateswarlu, Kavati and Konijeti Ramakrishna. "Effect of turbulence and multiple injection
437 strategies on homogeneous charge compression ignition (HCCI) diesel engines – a
438 review." *International Journal of Ambient Energy* (2019): n. pag. 858-872
- 439 [12] d'Ambrosio, S., Ferrari, A., Mancarella, A. et al. Effects of Rate-Shaped and Multiple Injection
440 Strategies on Pollutant Emissions, Combustion Noise and Fuel Consumption in a Low Compression
441 Ratio Diesel Engine. *Int.J Automot. Technol.* **21**, 197–214 (2020). [https://doi-](https://doi-org.ezproxy.biblio.polito.it/10.1007/s12239-020-0020-0)
442 [org.ezproxy.biblio.polito.it/10.1007/s12239-020-0020-0](https://doi-org.ezproxy.biblio.polito.it/10.1007/s12239-020-0020-0)
- 443 [13] Yarsam, Pravin, Abhijit. A. Athawale and Vaibhav kapadnis. "Adopting the Features of Digital
444 Rate Shaping (DRS) with Multiple Injections Strategy on Small 2 Cylinder Common Rail BSVI
445 Engine to Improve FE." *SAE Int. J. Adv. & Curr. Prac. in Mobility* 4(2):688-704, 2022,
- 446 [14] Busch, Stephen and Paul C. Miles. "Parametric Study of Injection Rates With Solenoid Injectors
447 in an Injection Quantity and Rate Measuring Device." *Journal of Engineering for Gas Turbines and*
448 *Power-transactions of The Asme* 137 (2014): 101503.
- 449 [15] Ferrari A, Mittica A. Response of different injector typologies to dwell time variations and a
450 hydraulic analysis of closely-coupled and continues rate shaping injection schedules. *Appl Energy*
451 2016;169:899–911.

- 452 [16] Busch S, Zha K, Miles PC. Investigations of closely coupled pilot and main injections as a mean
453 to reduce combustion noise. In: 8th thiesel conference on thermo and fluid dynamic processes in
454 direct injection engines, Valencia; 9th–12th September,2014.
- 455 [17] d’Ambrosio S, Ferrari A. Effects of pilot injection parameters on low temperature combustion
456 diesel engines equipped with solenoid injectors featuring conventional and rate-shaped main injection.
457 *Energy Convers Manage* 2016;110:457–68.
- 458 [18] Wang L, Li G, Xu C, Xi X, Wu X, Sun S. Effect of characteristic parameters on the magnetic
459 properties of solenoid valve for high-pressure common rail diesel engine. *Energy Convers Manage*
460 2016;127:656–66.
- 461 [19] Wintrich T, Hammer J, Naber D, Raff M, Rath C, Stapelmann A, et al. Motorsysteme. In: Liebl
462 J, Beidl C, editors. Proceedings of the Internationaler Motorenkongress 2015. Wiesbaden: Springer
463 Vieweg; 2015. p. 165–211.
- 464 [20] Finesso, Roberto and Ezio Spessa. “A control-oriented approach to estimate the injected fuel
465 mass on the basis of the measured in-cylinder pressure in multiple injection diesel engines.” *Energy*
466 *Conversion and Management* 105 (2015): 54-70.
- 467 [21] C. J. Moreno, O. Stenlaas and P. Tunestal, "Bayesian Method for Fuel Mass Estimation of Short
468 Pilot Injections based on its Misfire Probability," *2020 American Control Conference (ACC)*, 2020,
469 pp. 1507-1513, doi: 10.23919/ACC45564.2020.9147866.
- 470 [22] Jorques Moreno, C., Stenlåås, O., and Tunestål, P., “Cylinder Pressure Based Method for In-
471 Cycle Pilot Misfire Detection,” *SAE Int. J. Advances & Curr. Prac. in Mobility* 2(2):488-502, 2020,
472 doi:10.4271/2019-24-0017.
- 473 [23] Ferrari, Alessandro, Carlo Novara, Emilio Paolucci, Oscar Vento, Massimo Violante and Tantan
474 Zhang. “Design and rapid prototyping of a closed-loop control strategy of the injected mass for the
475 reduction of CO₂, combustion noise and pollutant emissions in diesel engines.” *Applied*
476 *Energy* (2018), pages 358-367, doi: 10.1016/j.apenergy.2018.09.028

- 477 [24] Ferrari, Alessandro, Carlo Novara, Emilio Paolucci, Oscar Vento, Massimo Violante and Tantan
478 Zhang. “A new closed-loop control of the injected mass for a full exploitation of digital and
479 continuous injection-rate shaping.” *Energy Conversion and Management* (2018): n. pag. 629-639, doi:
480 [10.1016/j.enconman.2018.08.037](https://doi.org/10.1016/j.enconman.2018.08.037)
- 481 [25] Zhang, Tantan. “An estimation method of the fuel mass injected in large injections in Common-
482 Rail diesel engines based on system identification using artificial neural network.” *Fuel* (2021):
483 122404, doi: [10.1016/j.fuel.2021.122404](https://doi.org/10.1016/j.fuel.2021.122404)
- 484 [26] Ferrari, Alessandro, Zhiru Jin, Oscar Vento and Tantan Zhang. “An injected quantity estimation
485 technique based on time–frequency analysis.” *Control Engineering Practice* 116 (2021): 104910.
- 486 [27] Hammer J, Raff M and Naber D, 2014. “Advanced diesel fuel injection equipment – A never
487 ending BOSCH story”. 14th Internationales Stuttgarter Symposium, Springer Vieweg, Wiesbaden,
488 Germany, March 18-19, 2014.
- 489 [28] Ishiduka K, Uchiyama K, Higuchi K, Yamada N, Takeuchi K, Herrmann OE, et al. “Further
490 innovations for diesel fuel injection systems: close-loop control of fuel quantity by i-Art & ultra high
491 injection pressure”. 19th Aachen colloquium, Aachen, 4th-6th October; 2010.
- 492 [29] Serizawa K, Ueda D, Mikami N, Tomida Y, Weber J. “Realizing robust combustion with high
493 response Diesel injector with controlled diffusive spray nozzle and closed loop injection control”.
494 SAE Technical Paper 2017-01-0845; 2017
- 495 [30] Beduneau JL, Bercher P, Cardon C, Meissonnier G, Uberti Bona M, Voigt P, et al. “Proceedings
496 of the SIA Powertrain conference”. 2014.
- 497 [31] Ferrari, A., & Zhang, T. (2019). “Benchmark between Bosch and Zeuch method–based
498 flowmeters for the measurement of the fuel injection rate”. *International Journal of Engine Research*,
499 22, 316 - 327.

- 500 [32] Ferrari, A., & Vento, O. (2020). "Influence of Frequency-Dependent Friction Modeling on the
501 Simulation of Transient Flows in High-Pressure Flow Pipelines". *Journal of Fluids Engineering-*
502 *transactions of The Asme, 142.*
- 503 [33] Ferrari, A., Mittica, A., Pizzo, P., & Jin, Z. (2018). "PID Controller Modelling and Optimization
504 in Cr Systems with Standard and Reduced Accumulators". *International Journal of Automotive*
505 *Technology, 19, 771-781.*
- 506 [34] Jin, Z., Vento, O., Zhang, T., Ferrari, A., Mittica, A., Ouyang, L., & Tan, S. (2021). "Numerical-
507 Experimental Optimization of the Common-Feeding Injection System Concept for Application to
508 Light-Duty Commercial Vehicles". *Journal of Energy Resources Technology-transactions of The*
509 *Asme, 143.*
- 510 [35] Ferrari, A., & Pizzo, P. (2016). "Optimization of an Algorithm for the Measurement of Unsteady
511 Flow-Rates in High-Pressure Pipelines and Application of a Newly Designed Flowmeter to
512 Volumetric Pump Analysis". *Journal of Engineering for Gas Turbines and Power-transactions of The*
513 *Asme, 138, 031604-031614.*