

TCAD-based Dynamic Thermal X-parameters for PA Self-Heating Analysis

Original

TCAD-based Dynamic Thermal X-parameters for PA Self-Heating Analysis / Donati Guerrieri, S.; Ramella, C.; Catoggio, E.; Bonani, F.. - ELETTRONICO. - (2022), pp. 13-16. (2022 17th European Microwave Integrated Circuits Conference (EuMIC) Milano (Italy) 26-27 September 2022) [10.23919/EuMIC54520.2022.9923459].

Availability:

This version is available at: 11583/2972808 since: 2022-12-27T12:06:00Z

Publisher:

IEEE

Published

DOI:10.23919/EuMIC54520.2022.9923459

Terms of use:

This article is made available under terms and conditions as specified in the corresponding bibliographic description in the repository

Publisher copyright

IEEE postprint/Author's Accepted Manuscript

©2022 IEEE. Personal use of this material is permitted. Permission from IEEE must be obtained for all other uses, in any current or future media, including reprinting/republishing this material for advertising or promotional purposes, creating new collecting works, for resale or lists, or reuse of any copyrighted component of this work in other works.

(Article begins on next page)

TCAD-based Dynamic Thermal X-parameters for PA Self-Heating Analysis

S. Donati Guerrieri^{#1}, C. Ramella^{#2}, E. Catoggio^{#3}, F. Bonani^{#4}

[#]Dipartimento di Elettronica e Telecomunicazioni, Politecnico di Torino, Italy
{¹simona.donati,²chiara.ramella,³eva.catoggio,⁴fabrizio.bonani}@polito.it

Abstract— TCAD simulations are used to extract an accurate temperature-dependent X-parameter active device model, which describes it as instantaneously dependent on the junction temperature, and hence represents the ideal framework to analyze device self-heating. Once exported from TCAD into EDA tools, X-parameters are coupled to a dynamic thermal impedance, leading to a compact and efficient device black-box model, allowing for circuit-level analysis of thermal memory effects in microwave circuits, like Power Amplifiers (PAs), even in presence of complex modulated-signal excitation. In particular, we focus on the thermal analysis of a class-A PA at E-band based on a 54 nm Si FinFET. The accuracy of the temperature-dependent X-parameter model is demonstrated first by comparing circuit simulations with TCAD results in continuous wave. Then we extend the analysis to pulsed modulated operation, highlighting thermal dynamic effects as a function of the pulse period.

Keywords— Semiconductor devices, Nonlinear device models, TCAD simulations, Thermal analysis, Self-heating

I. INTRODUCTION

The widespread deployment of FinFET technologies for advanced digital applications naturally leads to the exploration of the same technology also for analog high-frequency applications, thanks to their excellent performance in terms of cutoff and maximum oscillation frequencies, inherited by the nanometric size. Although limited to a few milliwatts of power, CMOS and FinFET technologies are promising in view of millimeter-wave (mmW) phased arrays for 5G/6G, where the required linear output power of each PA element can be as low as 4 dBm [1], [2]. However the peculiar structure of FinFETs also brings along several issues that must be addressed to make the technology a viable candidate for telecommunication systems, where successful integration of RF and digital circuits could represent a disruptive advantage. The FinFET 3D geometry, together with the need of resorting to multi-finger or stacked structures to achieve the required output power [2], [3], lead to higher parasitic effects, more pronounced technological variability and a very difficult thermal management due to the presence of low-thermal-conductivity materials [4]. As a consequence, accurate device electrothermal modeling is required for an effective design of RF circuits, such as power amplifiers (PAs), where device self-heating must be accurately described.

Among device modeling strategies, Technology CAD (TCAD) is the most effective approach whenever a direct link with technological parameters is required, e.g. in variability analysis [5] or to account for the

multiple temperature-dependent material properties of electron devices [6]. However, the numerical burden of TCAD simulations is very high, in particular for nonlinear device modeling, which can be addressed by means of Large-Signal (LS) simulations based on the Harmonic Balance (HB) technique. The TCAD computational cost suggests that it cannot be used for circuit design but rather as the basis to extract accurate, computationally efficient device models. Behavioral models, usually derived from measurements, have been recently proposed as the ideal framework to translate TCAD simulations (that can be regarded as *virtual device measurements*) into EDA tools for circuit design [7]. In this work we exploit the X-parameters (X-Pars) [8], directly extracted from our in-house drift-diffusion TCAD simulator which implements both HB LS and Small-Signal-LS analyses [9]. Although X-Pars can be made temperature-dependent as described in [10], their dependency on temperature can be only instantaneous. However, dynamic thermal behavior can be recovered through an external thermal impedance, i.e. by using a lumped description of the device junction temperature as a function of the dissipated power that includes memory effects. Most often a first order approximation is considered, exploiting a thermal capacitance in parallel to the device thermal resistance [11], [12].

Notice that, although X-Pars can be directly obtained from experimental characterization, this is hardly an advantage in the perspective of an electrical model parametrically depending on temperature. In fact, device characterization cannot be decoupled from self-heating unless very complex procedures are adopted (e.g. pulsed characterization or thermal resistance de-embedding [11]). Therefore, the experimental determination of the isothermal, temperature-dependent X-pars is a very difficult task. On the other hand, extracting X-pars from TCAD simulations avoids this problem entirely, as self-heating can simply be turned off during the electrical simulations.

In this contribution, we exploit the T -dependent X-par model of a 54 nm Si FinFET presented in [10], extracted from TCAD LS simulations, to implement a complete, dynamic electrothermal device model into Keysight ADS. We then demonstrate that the latter can be used to assess the dynamic self-heating of a PA stage based on the same FinFET, also with modulated input signals. We show, as an example, the pulsed-operated PA response, but the proposed approach can be extended to different operating conditions and modulations.

II. ELECTROTHERMAL MODEL IMPLEMENTATION

The FinFET T -dependent X-par model was extracted from TCAD changing the lattice temperature of the device as an independent parameter, and implemented into ADS as shown in Fig. 1.

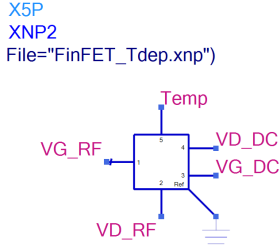

Fig. 1. Implementation of the TCAD model into ADS. The X-par file contains the X parameters extracted from TCAD at selected temperatures (here 300, 340 and 380 K). The DC $Temp$ terminal is an isolated DC-voltage port used to interpolate the X-par file as a function of temperature [10].

A 70 GHz PA for small-cell applications, was designed based on the selected FinFET. The PA, biased in class A, achieves an output power of 2 mW with 8 dB linear gain (see [10] for details). The T -dependent X-par model of Fig. 1 including 10 harmonics is accurate in reproducing the variations of the PA performance as a function of temperature, as shown in Fig. 2: here the PA circuit analysis carried out in ADS is compared against TCAD simulations of the same PA at varying temperatures. The accuracy has been verified also comparing the temperature dependency of the device current harmonics, shown in Fig. 3.

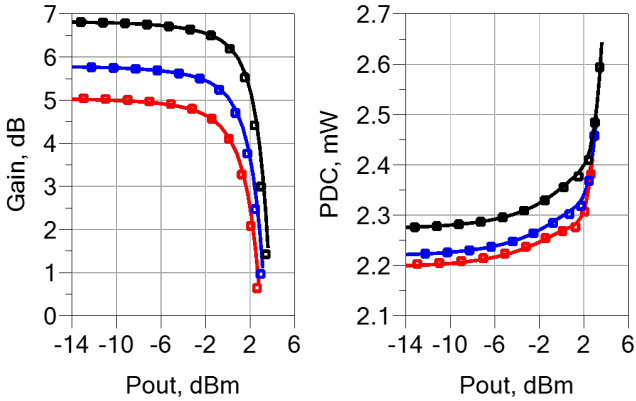

Fig. 2. Temperature-dependent analysis of the PA stage. Solid lines: ADS with X-parameters. Symbols: TCAD physics-based analysis. Black: $T=300$ K; Blue: $T=350$ K; Red: $T=390$ K.

From the simulation standpoint, when a time-varying temperature is present on the $Temp$ terminal in Fig. 1, the model predicts an instantaneous variation of the device electrical characteristics. To account for thermal dynamics and self-heating, instead, an external lumped RC thermal network is coupled to the X-par model as shown in Fig. 4. The instantaneous dissipated power in the device is calculated through an SDD (Symbolically Defined Devices of ADS)

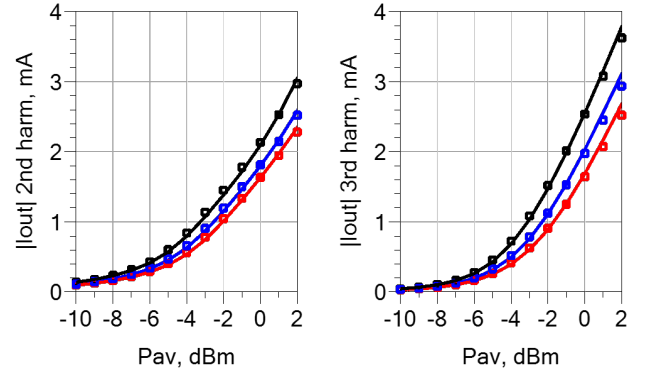

Fig. 3. Temperature dependency of the 2nd and 3rd harmonic of the device drain current. Solid lines: ADS with X-parameters. Symbols: TCAD physics-based analysis. Black: $T=300$ K; Blue: $T=350$ K; Red: $T=390$ K.

block, exploiting current probes in the circuit as controlling currents at selected ports. The instantaneous power is then fed as the current flowing through the RC thermal impedance block, yielding the junction temperature. The latter is applied to the $Temp$ terminal of the X-par model, dynamically selecting the values of the X-parameters as a function of the time-varying temperature. In this example, the thermal resistance is varied from 0.33 to 1 $K/\mu W$ (determined on the basis of the fin shape and of the silicon thermal conductivity), while the thermal capacitance is sized so as to yield a first-order thermal cut-off frequency of 10 kHz. Notice that from the electrical standpoint, X-pars represent a quasi-memoryless model, hence the slow thermal dynamic is here entirely due to the thermal impedance. To validate the implemented model, we exploit TCAD simulations including self-heating: the drift-diffusion equations are coupled to the thermal RC network adding the temperature as an additional dynamic variable. The coupled equations are solved self-consistently by means of the Harmonic Balance algorithm. Fig. 5 shows that the ADS model correctly predicts the FinFET self-heating: as expected in a class-A stage, the junction temperature decreases as a function of the input power, while in back-off the thermal dissipation is larger due to the DC power consumption and the lower PA efficiency.

III. PA SELF-HEATING WITH PULSED INPUT POWER

To highlight the capability of the implemented self-consistent dynamic electrothermal model, we tested the PA under pulsed RF operation [13], [14]. In this analysis, the thermal resistance is set to 1 $K/\mu W$. The input power is switched on ($P_{av} = -2$ dBm) and off with 50% duty cycle. Rise and fall time are set equal to 5% of the pulse duration. The modulated input power was obtained at circuit level using the $PtRF_Pulse$ component of ADS and $Envelope$ simulations are used to highlight the slow thermal dynamics of the stage. The carrier frequency is set to 70 GHz, which is the operating frequency of the designed stage. The resulting FinFET gate voltage is shown in Fig. 6: here the time range is normalized to 4 periods.

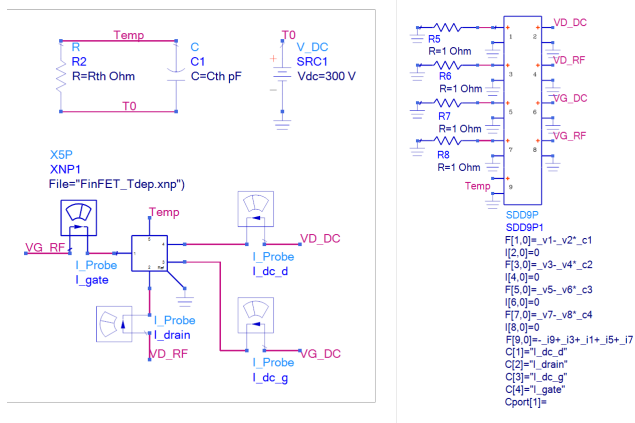

Fig. 4. Circuit implementation of the dynamic self-consistent thermal model. An *SDD* is used to compute the instantaneous power of the device, which is fed to the thermal impedance to evaluate the dynamic temperature value used as a parameter for the X-par model. This implementation follows [11].

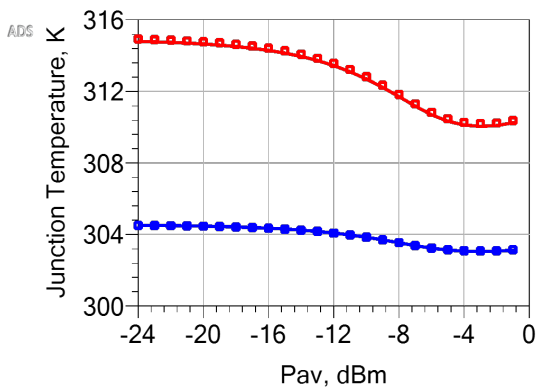

Fig. 5. Comparison of the FinFET junction temperature predicted, respectively by the self-consistent TCAD simulations and the ADS model in Fig. 4. The thermal resistance is $R_{th} = 0.3 \text{ K}/\mu\text{W}$ (blue) and $R_{th} = 1 \text{ K}/\mu\text{W}$ (red). Symbols: TCAD analysis. Solid lines: ADS circuit analysis.

We exploit three different pulse durations, namely 5 ms, 50 μs and 0.5 μs . Given the thermal cut-off frequency of 10 kHz (thermal time constant of 15 μs) we expect that the FinFET temperature follows the time-varying power envelope in the slower pulse case; exhibits a noticeable delay (rise/fall times) with respect to the power pulses in the intermediate case; and is essentially insensitive to power variations in the last, faster pulse, case. Fig. 7 shows the temperature baseband envelope in the three cases, confirming the expectations. Notice from Fig. 5 that the selected input power (-2 dBm) induces a significant temperature decrease. Therefore if the pulse duration is long enough the device exhibits thermal cooling.

Fig. 8 highlights the phase difference between the temperature baseband envelope and the output power fundamental envelope. In the slower case, temperature and power envelopes are in phase, while in the faster pulse case the temperature variations are essentially null over the entire pulse cycle. The hysteresis, typical of the thermal dynamic behavior

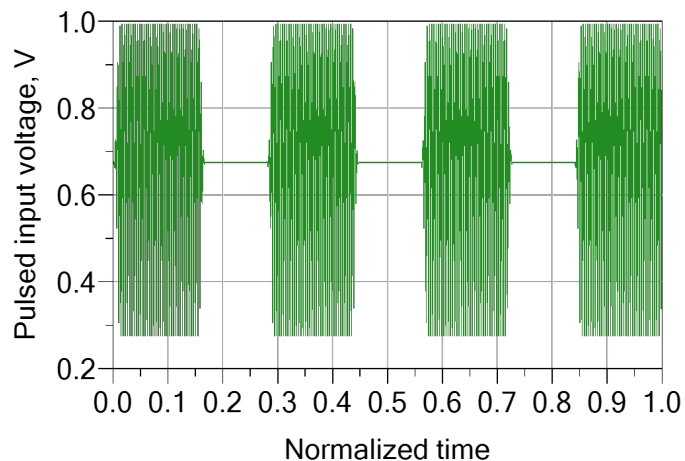

Fig. 6. Pulsed input for dynamic thermal self-heating analysis.

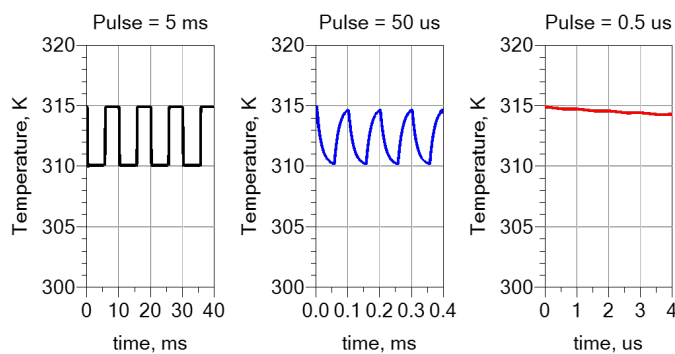

Fig. 7. Variation of the FinFET junction temperature baseband envelope as a function of time with three different pulse durations.

[11], is significant for a pulse duration close to the thermal time constant (intermediate case).

Fig. 9 shows the fundamental envelope of the PA available and output power in the three cases. The gain of the stage is about 7 (8 dB). As highlighted in the inset, the pulsed power is modulated by thermal effects, producing in the intermediate

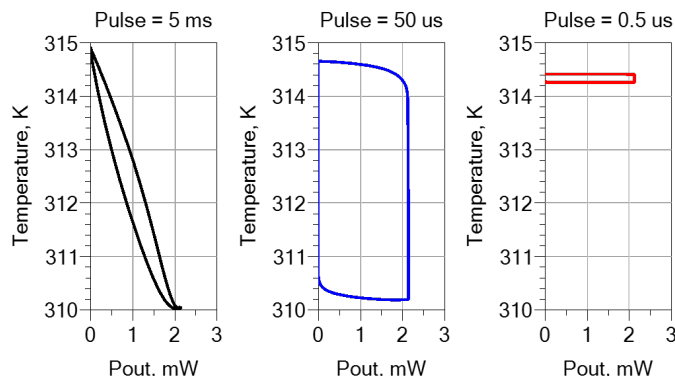

Fig. 8. Variation of the FinFET junction temperature as a function of the output power in pulsed operation.

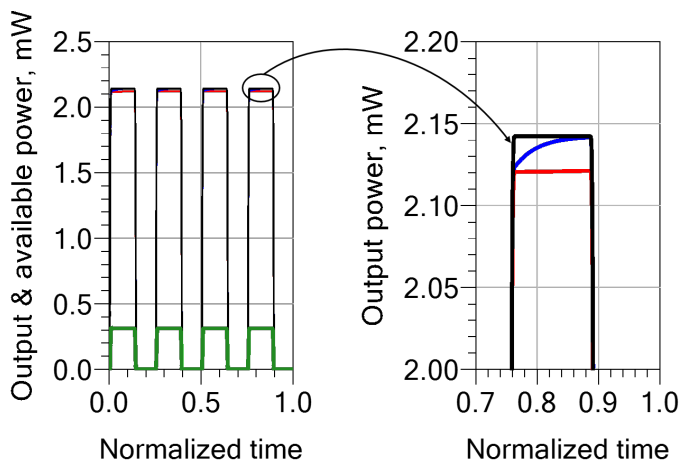

Fig. 9. Variation of the PA output power as a function of time (normalized over 4 periods) for three different pulse durations. The green curve represents the input power pulse envelope. The right figure shows the details of the output power envelope time-dependency during the on state.

case a non constant output over the pulse duration.

IV. CONCLUSION

We have presented an efficient implementation of a dynamic thermal model for a 54 nm FinFET device directly extracted from LS TCAD simulations via T -dependent X-params in a 50Ω environment. The model has been validated against LS TCAD analysis, including self-heating, by simulating a class A E-band power amplifier with single tone excitation. Exploiting the ADS envelope analysis we then demonstrate the effect of PA self-heating in pulsed operating conditions, highlighting the role of thermal memory. The proposed approach can be also extended to different input modulated sources, to evaluate the impact of temperature dynamics on PA performance, including the main linearity figures of merit, e.g. the AM-PM and ACPR.

ACKNOWLEDGMENT

This work has been supported by the Italian Ministero dell'Istruzione, dell'Università e della Ricerca (MIUR) under the PRIN 2017 Project "Empowering GaN-on-SiC and GaN-on-Si technologies for the next challenging millimeter-wave applications (GANAPP)"

REFERENCES

- [1] S. Callender, S. Pellerano, and C. Hull, "A 73 GHz PA for 5G phased arrays in 14nm FinFET CMOS," in *2017 IEEE Radio Frequency Integrated Circuits Symposium (RFIC)*. IEEE, jun 2017.
- [2] —, "An E -band power amplifier with 26.3% PAE and 24-GHz bandwidth in 22-nm FinFET CMOS," *IEEE Journal of Solid-State Circuits*, vol. 54, no. 5, pp. 1266–1273, may 2019.
- [3] H.-J. Lee, B. Sell, Y. Zhang, S. Morarka, S. Rami, Q. Yu, M. Weiss, G. Liu, M. Armstrong, C. Y. Su, and D. Ali, "Implementation of high power RF devices with hybrid workfunction and OxideThickness in 22nm low-power FinFET technology," in *2019 IEEE International Electron Devices Meeting (IEDM)*. IEEE, dec 2019.
- [4] K. Uchida and T. Takahashi, "Thermal-aware CMOS: Challenges for future technology and design evolutions," in *2016 46th European Solid-State Device Research Conference (ESSDERC)*. IEEE, sep 2016.
- [5] S. Donati Guerrieri, C. Ramella, F. Bonani, and G. Ghione, "Efficient sensitivity and variability analysis of nonlinear microwave stages through concurrent TCAD and EM modeling," *IEEE Journal on Multiscale and Multiphysics Computational Techniques*, vol. 4, pp. 356–363, 2019.
- [6] E. Catoggio, S. Donati Guerrieri, and F. Bonani, "Efficient TCAD thermal analysis of semiconductor devices," *IEEE Transactions on Electron Devices*, 2021.
- [7] S. Donati Guerrieri, C. Ramella, E. Catoggio, and F. Bonani, "Bridging the gap between physical and circuit analysis for variability-aware microwave design: Modeling approaches," *Electronics*, vol. 11, no. 6, p. 860, mar 2022.
- [8] D. Root, J. Horn, J. Verspecht, and M. Marcu, *X-Parameters*. Cambridge University Press, 2013.
- [9] S. Donati Guerrieri, M. Pirola, and F. Bonani, "Concurrent efficient evaluation of small-change parameters and green's functions for TCAD device noise and variability analysis," *IEEE Transactions on Electron Devices*, vol. 64, no. 3, pp. 1269–1275, mar 2017.
- [10] E. Catoggio, S. Donati Guerrieri, C. Ramella, and F. Bonani, "Thermal modeling of RF FinFET PAs through temperature-dependent X-parameters extracted from physics-based simulations," in *2022 International Workshop on Integrated Nonlinear Microwave and Millimetre-Wave Circuits (INMMiC)*. IEEE, Apr. 2022.
- [11] S. J. Gillespie, D. E. Root, M. Marcu, and P. H. Aaen, "Electrothermal X-Parameters for dynamic modeling of RF and microwave power transistors," in *2018 13th European Microwave Integrated Circuits Conference (EuMIC)*. IEEE, sep 2018.
- [12] F. Bonani, V. Camarchia, F. Cappelluti, S. Donati Guerrieri, G. Ghione, and M. Pirola, "When self-consistency makes a difference," *IEEE Microwave Magazine*, vol. 9, no. 5, pp. 81–89, oct 2008.
- [13] A. Chernenko and E. Ziganshin, "Pulse-doppler UWB radar," in *2006 3rd International Conference on Ultrawideband and Ultrashort Impulse Signals*. IEEE, sep 2006.
- [14] H. Matsumura, I. Soga, S. Shiba, K. Oishi, Y. Kawano, Y. Nakasha, and T. Suzuki, "E-band impulse radio transceiver with 2-bit pulse-position modulation," in *2018 15th European Radar Conference (EuRAD)*. IEEE, sep 2018.