

Effects of the Switching Frequency of Random Modulated Power Converter on the G3 Power Line Communication System

Original

Effects of the Switching Frequency of Random Modulated Power Converter on the G3 Power Line Communication System / Hamid Beshir, Abduselam; El Sayed, Waseem; Madi, Amr; Wan, Lu; Grassi, Flavia; Crovetto, Paolo S.; Wu, Xinglong; Liu, Xiaokang; Smolenski, Robert; Pignari, Sergio A.. - ELETTRONICO. - (2022), pp. 778-782. (2022 International Symposium on Electromagnetic Compatibility – EMC Europe Gothenburg, Sweden Sept. 5-8th, 2022) [10.1109/EMCEurope51680.2022.9901074].

Availability:

This version is available at: 11583/2972326 since: 2022-10-14T13:58:48Z

Publisher:

IEEE

Published

DOI:10.1109/EMCEurope51680.2022.9901074

Terms of use:

This article is made available under terms and conditions as specified in the corresponding bibliographic description in the repository

Publisher copyright

IEEE postprint/Author's Accepted Manuscript

©2022 IEEE. Personal use of this material is permitted. Permission from IEEE must be obtained for all other uses, in any current or future media, including reprinting/republishing this material for advertising or promotional purposes, creating new collecting works, for resale or lists, or reuse of any copyrighted component of this work in other works.

(Article begins on next page)

Effects of the Switching Frequency of Random Modulated Power Converter on the G3 Power Line Communication System

Abduselam Hamid Beshir⁽¹⁾, Waseem El Sayed⁽²⁾, Amr Madi⁽²⁾, Lu Wan⁽¹⁾, Flavia Grassi⁽¹⁾, Paolo S. Crovetti⁽³⁾, Xinglong Wu⁽¹⁾, Xiaokang Liu⁽¹⁾, Robert Smolenski⁽²⁾ and Sergio A. Pignari⁽¹⁾

(1) Politecnico di Milano, 20133 Milan, Italy

(2) University of Zielona Gora, 65-417 Zielona Góra, Poland

(3) Politecnico di Torino, 10129 Turin, Italy;

Abstract— Power Line Communication (PLC) technologies utilize existing power cables for both power and data transmission which minimizes cost and complexity. However, recent studies show that alternative modulation schemes such as Random Pulse Width Modulation (RPWM), applied to power converter to minimize conducted emissions, have possible side effects on the PLC system. In this work, the effects of the switching frequency of randomly modulated power converter on the G3-PLC system is investigated. To this end, a range of switching frequencies from 10 kHz-100 kHz is applied to a randomly modulated DC-DC converter and its potential effect on the G3-PLC is studied. Experimental results confirmed that switching frequencies near the bandwidth of the G3-PLC caused significant disturbance and possible coexistence issue compared to the frequencies out of this range. Therefore, there is a tradeoff between Electromagnetic Interference (EMI) reduction and coexistence issue that is Random Frequency Modulation, which is very effective for EMI reduction, is found to be very disruptive for G3-PLC, compared to alternative random modulation techniques like Random Pulse Position Modulation.

Keywords—conducted emission (CE), electromagnetic interference (EMI), power line communication (PLC), pulse width modulation (PWM), random pulse width modulation (RPWM)

I. INTRODUCTION

The modern society is becoming increasingly interconnected and electric power systems (generation, transmission, and distribution systems of electric energy) are providing, besides energy from the sources to the loads, a main path of communication systems. In many applications, electricity supply lines and communication systems use separate lines. However, in recent installations they were merged by resorting to the Power Line Communication (PLC) technology [1,2]. ~~The benefit of~~ transmitting power and data through a single interconnect is highly desirable in all those sectors in which reduction of cost, mass and weight is the target. Therefore, PLC is attracting increasing interest in different applications, i.e., Smart Grid (SG), Advanced Meter Infrastructure, home automation and Electric Vehicle [3,4].

G3-PLC is among the communication protocols which is being used in many applications such as in the SG framework. However, recently new research results exploited that even if PLC technologies are ideal for these applications, there are potential coexistence issues associated with the power converter modulation scheme being used, i.e., the alternative pulse width modulation scheme such as random modulation which is used to reduce the conducted emissions (CE's) from power converters [5,6]. Indeed, Random Pulse Width Modulation (RPWM) techniques are cost-effective

alternatives to the use of traditional EMI filters to reduce the CE exiting power converters [7-12].

In [13], the comparison between the deterministic and random modulation effects on the G3-PLC performance in terms of Frame Error Rate (FER) is presented. In that work, only one type of RPWM scheme, i.e., Random Frequency Modulation (RFM), is considered and it was found causing more FER than the deterministic modulation. Also, in [14] the influence of a random frequency modulated SiC-based buck converter on the G3-PLC Channel Capacity and Channel Loss is presented, and it is shown that the use of RFM reduces the G3-PLC channel performance compared to conventional Pulse Width Modulation (PWM). However, further investigations are required to decide which random modulation scheme is more suitable for power converters in applications involving PLC systems.

This work is aimed at investigating the effects of alternative RPWM such as Random Pulse Position (RPPM) schemes on G3-PLC system and at comparing the results with previous results, to understand the conditions under which RPWM can be considered as an effective alternative to conventional modulation schemes. To this end, the effects of the switching frequency of random modulated DC-DC converter on the G3-PLC system is investigated. Since the switching frequency of power converters is different from one application to the other, a range of switching frequencies from 10 kHz-100 kHz is considered and applied to the DC-DC converter. The performance of the G3-PLC is assessed based on the FER, Channel Capacity and Channel Loss. Moreover, the obtained results are compared with previous experimental findings obtained with other modulation strategies such as RFM, to understand which modulation scheme could better assure coexistence.

The remaining part of the manuscript is organized as follows. Section II introduces the details of Random Modulation. The description of the G3-PLC with the experimental test setup is presented in Section III. The obtained results are presented and discussed in Section IV. Finally, in Section V, conclusions are drawn.

II. RANDOM PULSE POSITION MODULATION

In RPWM, one of the switching parameters of the pulse width modulation (PWM) signal shown in Fig. 1 is varied randomly, where 'd' is pulse width, 'T' is switching period and 'α' denotes the pulse delay or position. Therefore, RPWM can be classified as Random Frequency Modulation

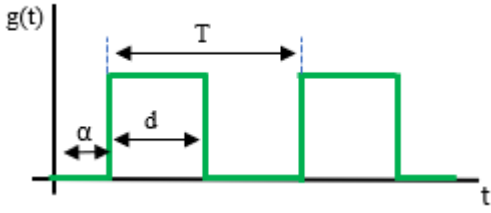

Fig. 1 Switching signal.

(RFM), Random Pulse Position Modulation (RPPM) and Random Pulse Width Modulation (RPWM), depending on the parameter which is made random. PWM/ RPWM can be easily implemented using TI controller and SIMULINK.

The code for specific modulation technique can be generated using SIMULINK and deployed to specific TI controller for real time operation. For conventional PWM, the ePWM module in SIMULINK can be programmed as follows and the details can be inferred from [15], [16].

$$TBPRD = \frac{TPWM}{2TBCLK} \quad (1)$$

$$\text{And } CMA = (1-D) \times TBPRD \quad (2)$$

where: TBCLK is the Time Base Clock; TBPRD is Time-Base Period; TPWM - Period of the PWM; CMA and CMPB are the reference compare A and B values.

However, the implementation of RPPM is a bit more complex. In this case, controlling the CMA and CMPB reference values according to (3) and (4) is required.

$$CMPB' = CMPB + \Delta CMPB \times RAND \quad (3)$$

$$CMA = 2 \times TBPRD - CMPB' - (D \times 2TBPRD) \quad (4)$$

where RAND is pseudo-random number between 1 and -1, CMPB' is the random CMPB value, D is the duty cycle and $\Delta CMPB$ is the change in CMPB reference. The randomization factor α or modulation index can be expressed as:

$$\alpha = \Delta CMPB / TBPRD \quad (5)$$

Note that UP/Down counter is selected with CMPB UP is 'Set' and CMA DOWN is 'Clear' for this specific RPPM set up. The random PWM starts when the counter counts up and reaches to CMPB reference and stops when the counter counts down and reaches to CMA value. Indeed, both the duty cycle and switching period are constant for RPPM as can be inferred from (3)-(4).

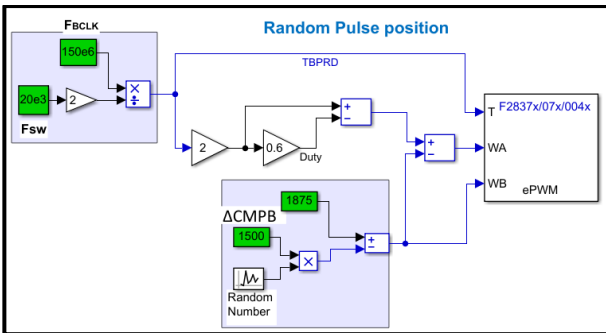

Fig. 2 SIMULINK schematics of the implemented RPPM.

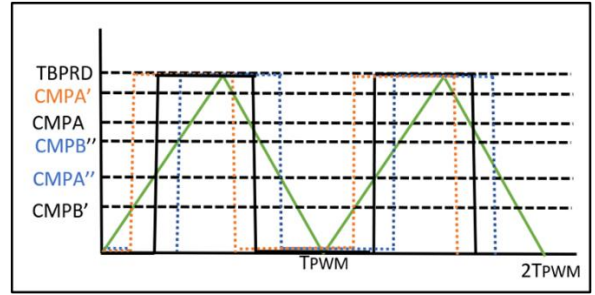

Fig. 3 PWM signals with different pulse position.

The setup implemented in SIMULINK for generating RPPM is shown in Fig. 2 and the resulting random PWM signal is depicted in Fig. 3.

III. EXPERIMENTAL TEST SETUP

Two G3-PLC modems are used to transmit data as a transmitter and receiver, with frequency band between 35 kHz-91 kHz as shown in Fig. 6. The two PLC modems are connected to a 42-meter-long 230 V AC cable and the communication signals transmitted at one end of the AC line is received in the other end. An isolation transformer is used to separate the AC line from the grid. The schematics of the circuit connection is shown in Fig. 4

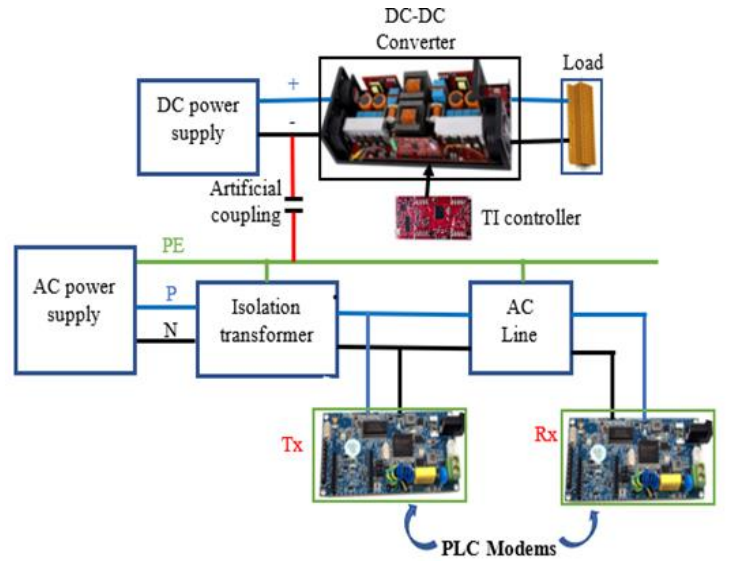

Fig.4 Schematics of system under analysis where the G3-PLC is coupled with the DC-DC converter.

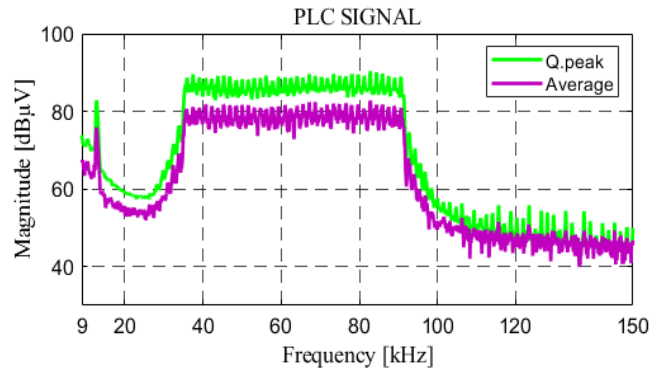

Fig. 5 The frequency spectrum of the G3-PLC signal.

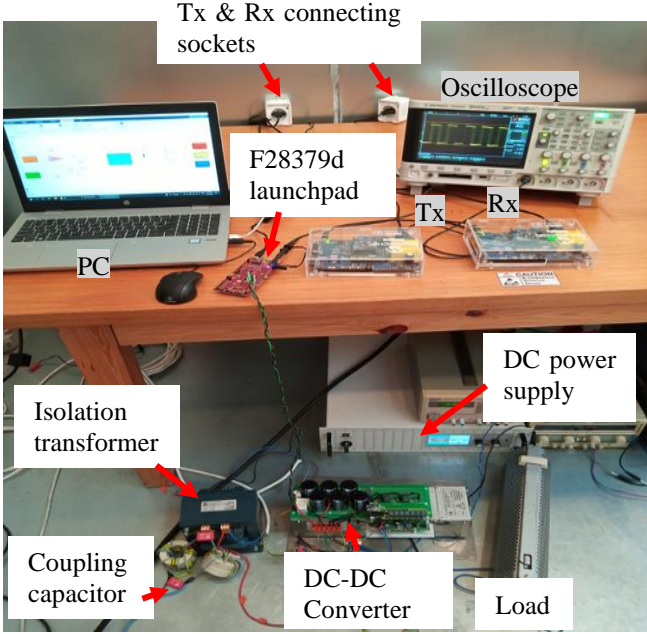

Fig. 6 Experimental test setup.

The AC line is coupled with the Random modulated DC-DC converter through a coupling capacitor of 10 nF. Hence, the noise generated from the DC-DC converter is coupled with the PLC system. F28379d launch pad from Texas Instruments is used to generate RPWM signals. A picture of the experimental test setup is shown in Fig. 6

IV. RESULT AND DISCUSSION

There are many parameters which can be controlled or affect the RPWM scheme. The spreading factor, the sampling time and the switching frequency are among them. In this work only the switching frequency is considered. Recent studies show that RPWM scheme, which is being used to pass EMC compliance test, is found disruptive to PLC systems. Therefore, it is necessary to see where and when RPWM can be used in combination with PLC. In addition, it is also interesting to compare different RPWM schemes so that, suitable modulation technique to assure co-existence can be chosen. The performance of the G3-PLC is evaluated based on the Frame Error Rate (FER), Channel Capacity and Channel Loss. The FER indicates the percentage of Frame of data which is correctly received from the total Frame data sent through the communication system, and can be determined as:

$$FER (\%) = \frac{Sent\ frames - Received\ frames}{Sent\ frames} \times 100 \quad (6)$$

The Channel Capacity tells the maximum bits of data that the communication system capable of transmitting [17].

$$C = \int_B \log_2(1 + S/N) df \quad (7)$$

where C is the Channel Capacity, B is the bandwidth of the G3-PLC, S is the power spectral density (PSD) of the G3-PLC and N is the PSD of the noise which is:

$$N = N_0 + N_{EMI} \quad (8)$$

where N_0 is the background noise and N_{EMI} is the noise from the power converter.

The channel loss can be determined as:

$$C_{Loss} (\%) = \frac{C_0 - C_{G3}}{C_0} \times 100 \quad (9)$$

Where C_{G3} and C_0 are the Channel Capacity of the G3-PLC with and without N_{EMI} .

To see the effects of the switching frequency of the converter on G3-PLC data, different switching frequencies are considered, some of them in the frequency range of the G3-PLC (35 kHz -91 kHz), others below and above the frequency range of the PLC system. This allows clearly appreciating the effects of the power converter switching frequency in the PLC system. Practically, the switching frequency of most of power converters varies from 10 kHz to 100 kHz. Hence, a range of frequencies between 10 kHz and 100 kHz is considered for this analysis. The results are compared by sending 3000 frame of data packages with delay time of 100 ms. The frame error rate, channel capacity and channel loss are compared for different switching frequencies of the power converter.

Fig. 7 shows the FER calculated from 3000 frame of data transmitted through the G3-PLC where different switching frequencies are applied to the DC-DC converter resorting to RPPM. The FER is significantly higher in the bandwidth of the G3-PLC (where the switching frequency of the DC-DC converter falls in the frequency range of 35 kHz-91 kHz) with peak FER around the intermediate frequency (60 kHz). However, the FER is not significant where the switching frequency of the DC-DC converter is out of the bandwidth of the G3-PLC. This result helps drawing the conclusion that RPPM could influence the G3-PLC only when the switching frequency of the power converter is in the bandwidth of the G3-PLC.

At this point it is also important to compare RPPM with other modulation schemes such as RFM from previously available works. The same analysis is carried out in [14] in which RFM causes significantly larger FER (50 %, see Table 1) than RPPM (8%) around the intermediate switching frequency (60 kHz). This is because the bandwidth of the noise of the DC-DC converter where RFM deployed is wider (more spread) than RPPM as shown in Fig. 8 where the comparison of CE with different modulation schemes (PWM, RFM and RPPM at 20 kHz switching frequency) is presented.

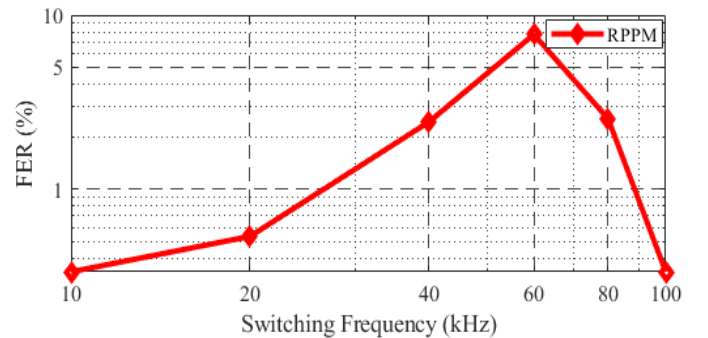

Fig. 7 FER of the G3 PLC v.s. the switching frequency of the DC-DC converter modulated with RPPM.

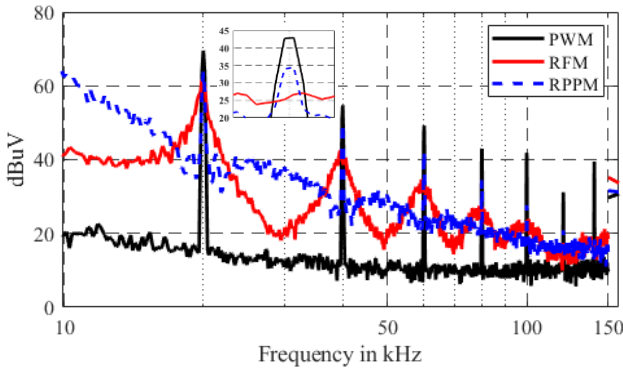

Fig. 8 Comparison of the CE of the DC-DC converter with different modulation techniques deployed.

Even if RFM is very good for EMI reduction compared to RPPM as depicted in Fig. 8, the latter is very good to assure coexistence. This corroborates the conclusion that choosing the right modulation scheme is a tradeoff between EMI reduction and coexistence issue.

Another important parameter to evaluate the effects of random modulation on the PLC system is the Channel Capacity. As depicted in Fig. 9, the Channel Capacity of the G3-PLC reduces when the switching frequency of the converter is near the intermediate frequency of the G3-PLC system. However, for switching frequencies out of the bandwidth of the G3-PLC, the Channel Capacity is not significantly affected.

It is also worth noticing that the Channel Capacity of the G3-PLC at the intermediate switching frequency near 60 kHz with RFM applied to DC-DC converter in [14] (390 kb/s at the spreading factor ‘ $\alpha=30\%$ ’) is lower than the result obtained here by resorting to RPPM (498 kb/s). This further confirms that RPPM outperforms RFM in assuring coexistence. Additionally, G3-PLC performance is assessed in terms of channel loss. The Channel Loss of the G3-PLC is significantly higher at the intermediate switching frequencies near 60 kHz as depicted in Fig. 10. Similarly, it is observed that RFM causes more Channel Loss (48% at the spreading factor ‘ $\alpha=30\%$ ’) (see Table 1) than RPPM (18%).

TABLE I. SUMMARY OF THE PERFORMANCE OF G3 PLC UNDER RFM (WOREST CONDITION @ 30% MODULATION INDEX) [14].

Frequency (kHz)	G3-PLC performance		
	Channel Capacity (kb/s)	FER(%)	Channel Loss (%)
60-63	390	50	48

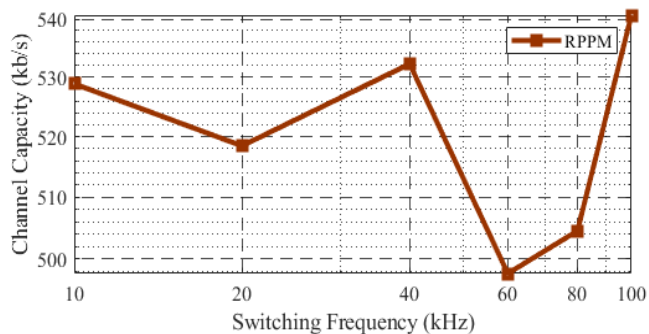

Fig. 9 Channel Capacity of the G3-PLC with different switching frequencies applied to the RPPM modulated DC-DC converter.

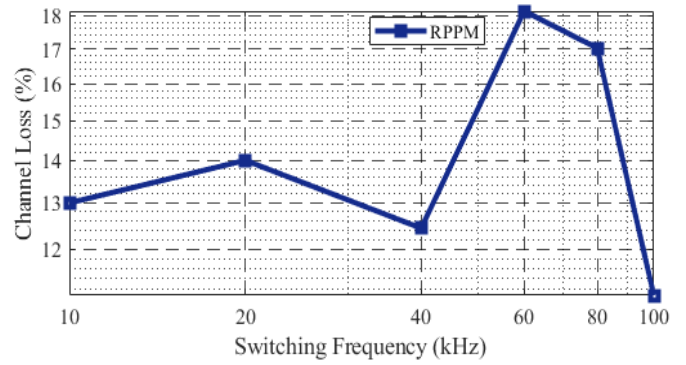

Fig. 10 Channel Loss of the G3-PLC with different switching frequencies applied to the RPPM modulated DC-DC converter.

V. CONCLUSION

In this paper the effects of RPWM on the G3-PLC system is investigated. Among the different types of random modulation schemes, RPPM is considered in this paper and its effect is compared with RFM. Among the parameters which influence the RPWM, this paper focuses on the effects of the switching frequency of randomly modulated power converter on the G3-PLC. To this end, different switching frequencies are applied to the randomly modulated DC-DC converter to show the range of frequencies which more severely affect the G3-PLC. The communication channel is evaluated based on FER, Channel Capacity and Channel Loss. Based on the obtained results, the switching frequencies in the range near the bandwidth of the G3-PLC causes or disturbs the PLC system more than the switching frequencies out of the frequency bandwidth. Moreover, this paper tried to show that even if RPWM techniques are not effective to assure coexistence, there is tradeoff between them. Results in this paper showed that, RPPM is more suitable in applications where PLC technology is used, than RFM. However, the latter is superior in terms of EMI reduction.

ACKNOWLEDGMENT

This paper is part of a project that has received funding from the European Union’s Horizon 2020 research and innovation program under the Marie Skłodowska-Curie grant agreement No 812753 – ETOPIA.

REFERENCES

- [1] Ancillotti, E.; Bruno, R.; Conti, M. The role of communication systems in smart grids: Architectures, technical solutions and research challenges. *Comput. Commun.* 2013, 36, 1665–1697. ISSN 0140-3664. <https://doi.org/10.1016/j.comcom.2013.09.004>.
- [2] Barmada, S.; Raugi, M.; Tucci, M.; Maryanka, Y.; Amrani, O. PLC systems for electric vehicles and Smart Grid applications. In *Proceedings of the 2013 IEEE 17th International Symposium on Power Line Communications and Its Applications*, Johannesburg, South Africa, 24–27 March 2013; pp. 23–28.
- [3] Uribe-Pérez, N.; Angulo, I.; Hernández-Callejo, L.; Arzuaga, T.; De la Vega, D.; Arrinda, A. Study of Unwanted Emissions in the CENELEC-A Band Generated by Distributed Energy Resources and Their Influence over Narrow Band Power Line Communications. *Energies* 2016, 9, 1007
- [4] Ngcobo, T.; Ghayoor, F. Study the Topology Effect on a G3-PLC based AMI Network. In *Proceedings of the 2019 Southern*
- [5] Beshir, A.H.; Wan, L.; Grassi, F.; Crovetto, P.S.; Liu, X.; Wu, X.; El Sayed, W.; Spadacini, G.; Pignari, S.A. Electromagnetic Interference of Power Converter with Random Modulation on the Power Line Communication System. *Electronics* 2021, 10, 2979. <https://doi.org/10.3390/electronics10232979>

- [6] El Sayed, W.; Loschi, H.; Smolenski, R.; Lezynski, P.; Lok, C.L. Performance Evaluation of the Effect of Power Converters Modulation on Power line Communication. In Proceedings of the Sterowanie w Energoelektronice i Nap, edzie Elektrycznym (SENE), Łódź, Poland, 20–22 November 2019.
- [7] K.K. Tse, H.S.-Chung, S.Y. Huo and H.C. So, "Analysis and spectral characteristics of a Spread-Spectrum technique for conducted EMI suppression," in IEEE Trans. Power Electron., vol. 15, no.2, pp. 399-410, Mar. 2000.
- [8] C.M.Liaw, Y.M.Lin, C.H.Wu and K.I.Hwu, "Analysis, Design, and Implementation of a Random Frequency PWM Inverter," in IEEE Transactions on Power Electronics, vol.15, no.5, pp.843-854, Sept. 2000.
- [9] A.C.B.Kumar and G.Narayanan, "Variable switching frequency PWM Technique for Induction Motor Drive to Spread Acoustic Noise Spectrum with reduced current ripple," in IEEE Transactions on Industry Applications, vol.52, no.5, pp.3927-3938, Sept.-Oct.2016.
- [10] Haiyan Guo, Zhaoji Li, Bo Zhang and Zehong Li, "Conducted EMI Suppression By Random Frequency Modulation Techniques," 2009 Int. Conf. Communications, Circuits and Systems, Milpitas, CA, 2009, pp.693-696
- [11] C.Qi.X.Chen and Y.Qiu, "Carrier-Based Randomized Pulse Position Modulation of an Indirect Matrix Converter for Attenuating the Harmonic Peaks," IEEE Trans. Ind. Applications ,vol. 28, no.7, pp.3539-3548, July 2013.
- [12] Lezynski, P., Smolenski, R., Loschi, H., Thomas, D., & Moonen, N. (2020). A novel method for EMI evaluation in random modulated power electronic converters. *Measurement*, 151, 107098.
- [13] Sayed, W.E.; Lezynski, P.; Smolenski, R.; Madi, A.; Pazera, M.; Kempski, A. Deterministic vs. Random Modulated Interference on G3 Power Line Communication. *Energies* 2021, 14, 3257. <https://doi.org/10.3390/en14113257>
- [14] Sayed, W.E.; Lezynski, P.; Smolenski, R.; Moonen, N.; Crovetto, P.; Thomas, D.W.P. The Effect of EMI Generated from Spread Spectrum-Modulated SiC-Based Buck Converter on the G3-PLC Channel. *Electronics* 2021, 10, 1416.
- [15] S. B. Santra, K. Bhattacharya, T. R. Chudhury and D. Chatterjee, "Generation of PWM Schemes for Power Electronic Converters," 2018 20th National Power Systems Conference (NPSC), 2018, pp. 1-6, doi: 10.1109/NPSC.2018.8771819.
- [16] Datasheet TMS320F28379D Texas Instruments, <http://www.ti.com/lit/ds/symlink/tms320f28374d.pdf>
- [17] F. Musolino and P. S. Crovetto, "Interference of Spread-Spectrum Modulated Disturbances on Digital Communication Channels," in IEEE Access, vol. 7, pp. 158969-158980, 2019, doi: 10.1109/ACCESS.2019.2951059.