

From scan-to-BIM to a structural finite elements model of built heritage for dynamic simulation

*Original*

From scan-to-BIM to a structural finite elements model of built heritage for dynamic simulation / Ursini, Andrea; Grazzini, Alessandro; Matrone, Francesca; Zerbinatti, Marco. - In: AUTOMATION IN CONSTRUCTION. - ISSN 0926-5805. - ELETTRONICO. - 142:104518(2022), pp. 1-13. [10.1016/j.autcon.2022.104518]

*Availability:*

This version is available at: 11583/2970503 since: 2022-08-05T21:45:26Z

*Publisher:*

Elsevier

*Published*

DOI:10.1016/j.autcon.2022.104518

*Terms of use:*

This article is made available under terms and conditions as specified in the corresponding bibliographic description in the repository

*Publisher copyright*

(Article begins on next page)

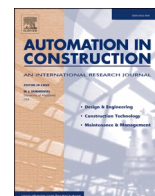

# From scan-to-BIM to a structural finite elements model of built heritage for dynamic simulation

Andrea Ursini<sup>a</sup>, Alessandro Grazzini<sup>b</sup>, Francesca Matrone<sup>c,\*</sup>, Marco Zerbinatti<sup>b</sup>

<sup>a</sup> Freelance Engineer - Via Roma 61, 65014, Loreto Aprutino (PE), Italy

<sup>b</sup> Department of Structural, Geotechnical and Building Engineering (DISEG), Politecnico di Torino, Corso Duca degli Abruzzi 24, 10129 Torino, Italy

<sup>c</sup> Department of Environment, Land and Infrastructure Engineering (DIATI), Politecnico di Torino, Corso Duca degli Abruzzi 24, 10129 Torino, Italy

## ARTICLE INFO

### Keywords:

Built heritage  
3D integrated survey  
3D modelling  
Point cloud  
HBIM  
NURBS interoperability  
Dynamic simulation  
Finite elements model (FEM)  
Seismic analysis

## ABSTRACT

The progress in information technology allows an innovative transformation of practices commonly involved in the engineering and construction field, especially in relation to the existing architectural heritage's control and management activities. The proposed methodology takes advantage of an integrated 3D metric survey as a basis for an HBIM (Historic Building Information Modelling) model to be exploited for the definition of a Finite Elements Model (FEM). This paper aims to show the applicability of a digital process, stemmed from the integration in Rhinoceros 3D of a BIM structural model, leading to the dynamic simulation of the analytical FEM through PRO\_SAP® (a PROfessional Structural Analysis Program). The described workflow investigates the interoperability issues, along with the difficulties in the Scan-to-HBIM processes, demonstrating how HBIM models can anyhow support operations aimed at maintaining and preserving existing historical assets, also from a structural point of view, even if with still persistent criticalities.

## 1. Introduction

The losses caused by steadily more exceptional natural phenomena, which constantly threaten historical and cultural assets, have contributed to the increased interest and need for new technical and practical solutions for the conservation and restoration of architectural heritage. In addition to these aspects, the damages and deterioration caused by lack of maintenance over time have indeed pushed forward to the use of new technologies to document the heritage.

From this framework, it is easy to understand the fundamental role of the documentation and knowledge of cultural heritage (CH) in generating a solid information background usefully aimed at its conservation over time [1,2].

In accordance with the latest technological developments in the field of Architecture, Engineering and Construction (AEC) and Facility Management (FM), the BIM (Building Information Modelling) methodology has been increasingly exploited to manage and digitise cultural heritage resources, using HBIM (Historic BIM) models. This widespread and emerging practice has been encouraged by the development of new integrated 3D metric survey techniques (laser scanners, UAVs, etc.), which provide consistent support for the digital reconstruction of parametric models through the scan-to-BIM processes. The HBIM, therefore, allows

the structuring of historical, technical and constructive information in a single digital 3D model, facilitating the cataloguing and consultation of data, which is useful for multiple purposes.

With this contribution, therefore, we set the goal of testing whether the union between an adequate interpretation of the historical phases, an integrated 3D metric survey and the consequent BIM-based modelling, with the aid of dynamic structural analyses models, can be considered a valid tool for the conservation and maintenance (planned and preventive) of these assets. This objective involves evaluating the effectiveness of a computerised technology applied to the existing built heritage, highlighting its drawbacks and strengths, understanding how it can support a restoration project (or a maintenance program), with the establishment of a simplified structural analytical model for the simulation of the crisis phenomena of the masonry topped by a roofing system with wooden structure and stone roof covering. This work, that integrates what has been already developed in the previous years by the Politecnico di Torino on the devotional complex of the "Sacro Monte di Varallo" [3,4], has also the task of proving how versatile this novel method is, standardisable and reproducible at different scales.

Exploiting the versatility offered by a three-dimensional model created in a BIM environment, it was possible to identify how to easily convert an architectural geometric model into a simplified analytical

\* Corresponding author.

E-mail addresses: [alessandro.grazzini@polito.it](mailto:alessandro.grazzini@polito.it) (A. Grazzini), [francesca.matrone@polito.it](mailto:francesca.matrone@polito.it) (F. Matrone), [marco.zerbinatti@polito.it](mailto:marco.zerbinatti@polito.it) (M. Zerbinatti).

one to be used in a finite element structural calculation software such as PRO\_SAP®. By applying this innovative procedure, it is also possible to evaluate how to guarantee a sufficiently high level of detail, in order to obtain more reliable results in terms of stresses and deformations during the representation and simulation phases with tools external to Autodesk Revit. The whole proposed workflow has also been analysed to promote an optimisation of the coordination between the various actors and stakeholders participating in the different phases of intervention (maintenance, conservation, restoration) by implementing a replicable and agile workflow that guarantees the correct interoperability and transfer of geometric information between the several software.

Therefore, the research addresses the following issues: i) *interoperability* of HBIM models to be used as the basis for performance and structural assessment, though operations of conversion and exchange of information between various software; ii) *digital representation of irregular geometries* within the HBIM models, tackled using NURBS through Rhinoceros and the GiD software; iii) *overlong Scan-to-HBIM process* even more complicated when it comes to structural purposes. In particular, by exploiting the interoperability challenges, it has been possible to build a geometric model of multidisciplinary value, capable of interfacing with software of specific nature, such as those belonging to the structural field.

### 1.1. Related works

The technological progress, as well as the development of Mobile Mapping Systems (MMS), considerably speeded up the data acquisition, leading to the ever-increasing use of point clouds and to the efficient application of the BIM methodology also to historical buildings of cultural interest [5–7]. Historic BIM [8–10], as we know it today, is a fundamental methodology for the study, management and development of CH conservation practices, and its modelling process is strongly supported by 3D metric surveys [11–16]. Indeed, the possibility of associating technical and historical information with three-dimensional geometries makes this methodology particularly suitable for applications in the CH domain.

The growing use of HBIM models is certainly due to their versatility, they are used for different purposes such as fruition and virtual reconstruction [17–19], as support for conservation, restoration and maintenance activities [20–24] or for analyses ranging from those with a high level of detail, such as the archaeological ones [25,26], up to the energetic or on a territorial scale [27–29]. Although this methodology is increasingly used, issues remain in the three-dimensional parametric modelling of complex architectural elements [30] and, consequently, this complicates its use for structural analyses.

Nowadays the market offers the possibility to integrate BIM software with special packages precisely designed for finite element analysis (FEA), but the main limitation lies in the reduced ability of these plugins to interpret geometric complexity, usually typical of buildings of historical interest. This is mainly due to the selection of BIM technology mostly aimed at designing and managing new buildings, characterised by standardised technological solutions and simple formal canons, with repetitive architectural elements, hardly present in historical architecture.

In this context, the contribution given by point clouds, mainly used to support the HBIM modelling phases, has already provided aid for the semi-automatic generation of finite element models [31–33]. Nevertheless, we considered useful to propose a methodology that exploits the geometries of HBIM models as a basis for FEAs. This choice is primarily due to the definition of the Italian UNI 11337 standard and the issuance of the Ministerial Decree 560/2017, that will make BIM and HBIM models increasingly used in the near future. It is therefore advantageous to be able to exploit them, even if without any point clouds. In this regard, some studies [34–37] have developed and tested methods for the use of HBIM models for structural analyses; however, the software used to verify the dynamic behaviour of structures consisting of a wide

variety of materials, such as wooden structures, were considered too elaborated. In our case, PRO\_SAP® proved to be a valid support for the linear dynamic analysis of the case study, complex and composed by masonry, leading to significant results in terms of stability and safety.

Other works, such as [38] tries to exploit the object-oriented models for preventive conservation considering damages and environmental parameters, but still no automatic (or semi-automatic) workflow is proposed. As described in [39], there are several works dealing with the use of BIM models to monitor buildings for structural reinforcement, however, the authors point out that the main gaps remain: i) a low level of integration of the HBIM models for performance assessment and structural monitoring, ii) a high number of steps from the point clouds to the parametrised model and iii) difficult recognition and reconstruction of curved historical geometries. Thus the proposed methodology tries to address these drawbacks, demonstrating a simpler workflow able to step from the initial point cloud to the intermediate HBIM model to ensure the final structural analyses. As further contributions of the paper, this procedure also identified the structural state of the analysed building and additionally demonstrated the still present lack of interoperability of the object-oriented software when dealing with historic buildings.

### 1.2. The case study

The *Sacro Monte* of Varallo was built at the end of the 15th century in Valsesia, an alpine valley in north-western Italy. The research work was applied to the Nazareth architectural complex (Fig. 1a) which includes chapels 2 (“Annunciation”), 3 (“Visitation”) and 4 (“First Dream of Joseph”), a set of structures now part of a knotty building, formed through modifications and additions conducted over a long period. For the historical and constructive framework of this nucleus within the entire complex of the *Sacro Monte* di Varallo, reference can be seen in [3,40].

In particular, the construction of the Nazareth complex dates back a little later than 1514 and is a modestly sized system with simple morphological characters. The main entrance of the building consists of a vaulted room that leads to chapel 2, containing wooden statues depicting the “Annunciation to the Virgin Mary”. On its right, there is a *portico* (Fig. 1b), which protects chapel 3 (Fig. 1c) and from which a staircase takes to chapel 4, a lower part of the building.

The chapels are characterised by separation from the external environment only through perforated wooden or lead-welded gratings or by windows; this peculiarity makes them particularly vulnerable to degradation phenomena such as detachment of plasters, gaps in the wall faces, mould due to the high presence of humidity and biodeteriogenic agents. In the specific case of the Nazareth complex, given the evident state of deterioration of some structures, extraordinary maintenance and restoration works of the roofing coverings were necessary (Fig. 1d), as well as operations for the water treatment and its removal from the basement of the walls.

These structural weakenings irreparably cause a reduction in the performance level of the materials constituting the walls. This weakening can lead to the anticipated crisis of the masonry walls due to the exceeding resistance limits of the materials, under both the actions of the structure (own weight), the actions resulting from winds or heavy snow, and those deriving from earthquakes or landslides. Precisely for this reason, an in-depth study and FEM analysis of the walls and vaulted surfaces are deemed necessary to understand their mechanisms of structural resistance.

## 2. Methodology

The data exchange between professionals and stakeholders is of crucial importance in the scenarios with interventions for the safety and preservation of monumental historical assets, where it is essential to be able to build a finite element model from a three-dimensional geometric survey [1]. In many cases, the Italian technical legislation requires the preliminary assessment of seismic safety, as an indispensable starting

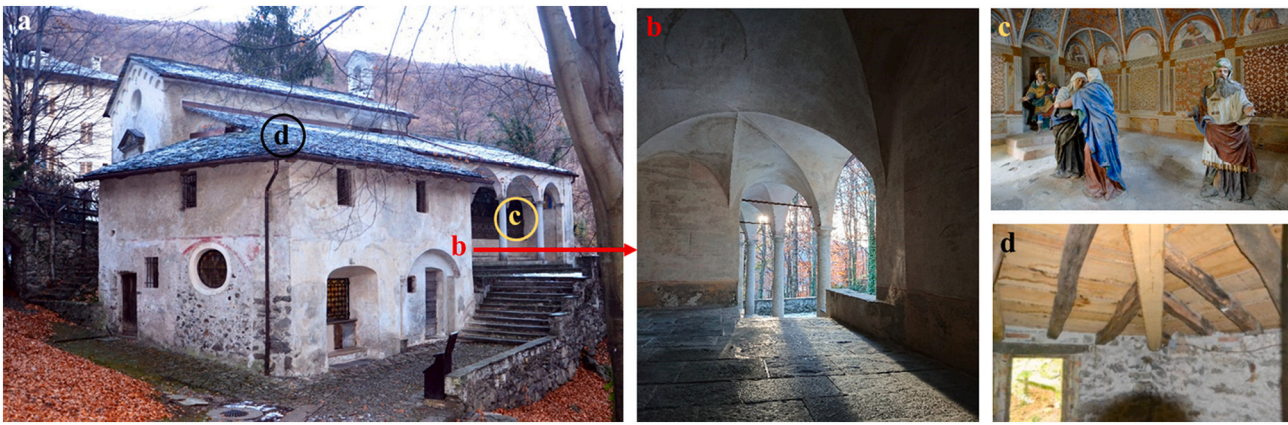

Fig. 1. The complex of Nazareth (a) with, in detail, the protective portico with starry vaults system (b), an interior view of chapel 3 “the Visitation” (c) and conservation intervention with a new angular supporting beam beneath the original secondary beams (d).

point for planning the subsequent safety measures and seismic improvement of historic buildings, and this is precisely one of the main reasons behind the methodology proposed.

Starting from an accurate metric survey and through a scan-to-BIM process, it was, therefore, possible to obtain an analytical simulation for structural purposes.

For the investigations (diagnostic and modelling) [1], the workflow (Fig. 2) began with the integrated metric survey, namely the acquisition and processing of terrestrial laser scanner (TLS) and aerial photogrammetric data [3]. Two different software was used to process the data obtained, commercial and open-source, respectively FARO SCENE and MicMac. By exploiting versatility and information interchange [41], it was possible to generate a dense point cloud, which then constituted the real reference base of the entire modelling process in the object-oriented environment: Autodesk Revit Architecture. The choice of this software was due to different factors:

- the extensive use of this software among professionals and in university courses. In fact, although there are other several object-oriented software, Autodesk Revit is the one currently most used;
- the case study proposed is part of a cross-border Italy-Switzerland inter regional project (Interreg “MAIN10ANCE”<sup>1</sup>), which involves the creation of HBIM models for the whole system of the Sacri Monti and, within this project, Revit was chosen as the modelling software;
- even by modelling with other software, such as Rhinoceros - or in any case in an external CAD - there is the possibility of creating a direct link (bridge) of the models; therefore, the use of Revit, especially under the informative aspect of BIM, allows to stratify information at multiple levels of analysis. It should be noted that the parallel use and integration of Rhinoceros with Revit has been under development for some years now. This has led to the creation of a new interchange system recently released (*Rhino.Inside.Revit*), which permits the direct connection between the two platforms. So the concept of modelling is no longer to be separated into a BIM model or CAD model, but it goes in the direction of integrating these two 3D modelling paradigms.

Having encountered some critical issues during the modelling phase, the 3D digital object was subsequently integrated at a geometric level through Rhinoceros 3D and the GiD 14.1.2d tool in order to convert the mesh into triangular and quadrangular meshes of a suitable size for the phase of FEA [42]. The FEA was performed with a linear dynamic analysis using the PRO\_SAP® software [43] in seismic combination and with the verification according to the requirements of the Technical

Standards for Italian Construction (NTC 2018) [44–46].

The exchange of information between the BIM model and the analysis software was possible exclusively by using a Drawing Interchange Format (.dxf) extension since the Industry Foundation Classes (.ifc) standard was not suitable for this case study due to an incorrect transmission and coding of data.

### 2.1. Data acquisition: integrated metric survey

As previously mentioned, to obtain a detailed integrated 3D metric survey of the Nazareth complex (Fig. 3), it was decided to use a combination of several tools, intended for the realisation of different types of acquisitions. First of all, the measurement of a topographic network was carried out for georeferencing the acquired data. The traditional topographic survey was realised with a Leica Nova Scan total station, through which a framing network consisting of six external vertices was defined, with the further identification of two internal vertices essential for the next side shots acquisition. Geomax GPS/GNSS receivers were also used to acquire vertexes’ geographical position and to allow RTK (Real Time Kinematic) measurements for the other GCPs (Ground Control Points).

The geodetic network compensation was performed using the STAR\*NET software, and it was computed with error ellipses at 95% and semiaxes of a maximum 2 cm (standard deviation  $\leq 1$  cm) (Fig. 4a).

Afterwards, were acquired:

- 24 laser scans (Fig. 4b) with FARO Focus 3D by CAM2 (operating range 0,6–130 m, ranging error  $\pm 2$  mm and vertical/horizontal Field of View 305°/360°)
- 131 images (59 nadiral and 72 obliques) via Unmanned Aerial Vehicles (UAVs), precisely the DJI Phantom 4 Pro (with sensor size 1” CMOS, 20 MP camera and focal length 8.8 mm) for the integration of the external roofing data.

### 2.2. Data processing

Laser scans were registered with an average accuracy of  $\pm 5$  mm for a representation scale of 1:100. The same range of accuracy was chosen for the GCPs of the photogrammetric point cloud, where the maximum error on the GCPs was lower than 1 cm. The point cloud thus obtained (Fig. 5a) turns out to be incomplete, especially in those portions of the building for which the laser scanner was not able to acquire the data: the roofing parts. For this reason, the aero-photogrammetric RGB images were processed using the open-source MicMac software (Fig. 5b).

The two point clouds were easily integrated thanks to the use of identical GCPs and targets within the same topographic network, which allowed to avoid manual or forced roto-translation operations. After

<sup>1</sup> <https://main10ance.eu/>

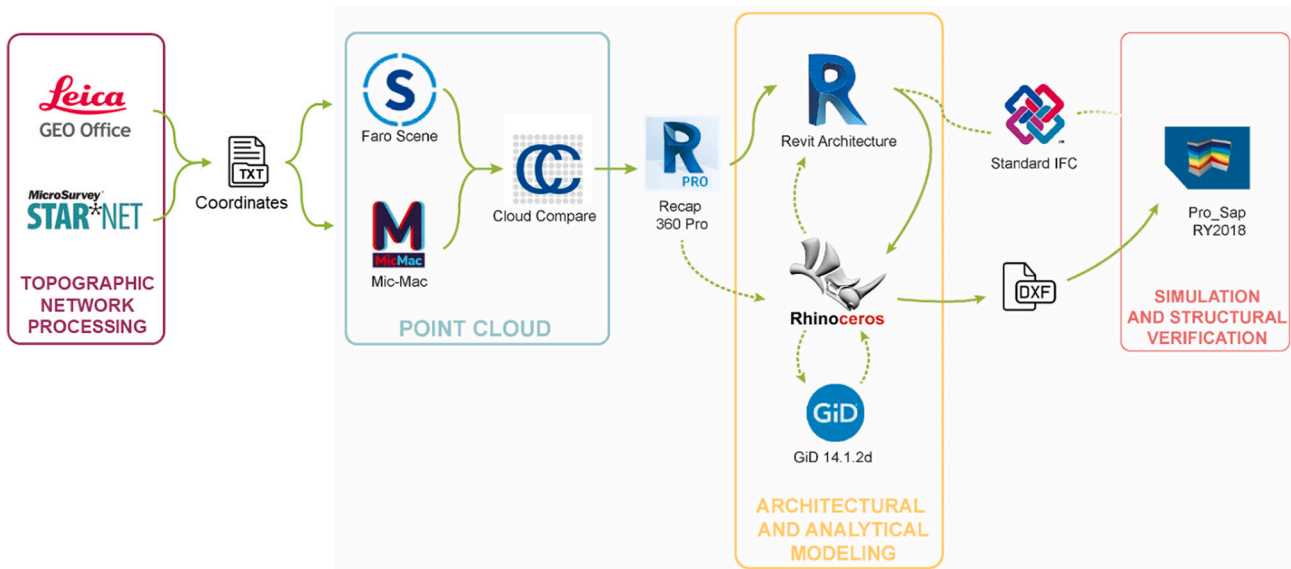

Fig. 2. Representative diagram of the workflow and related software used in the different processing phases.

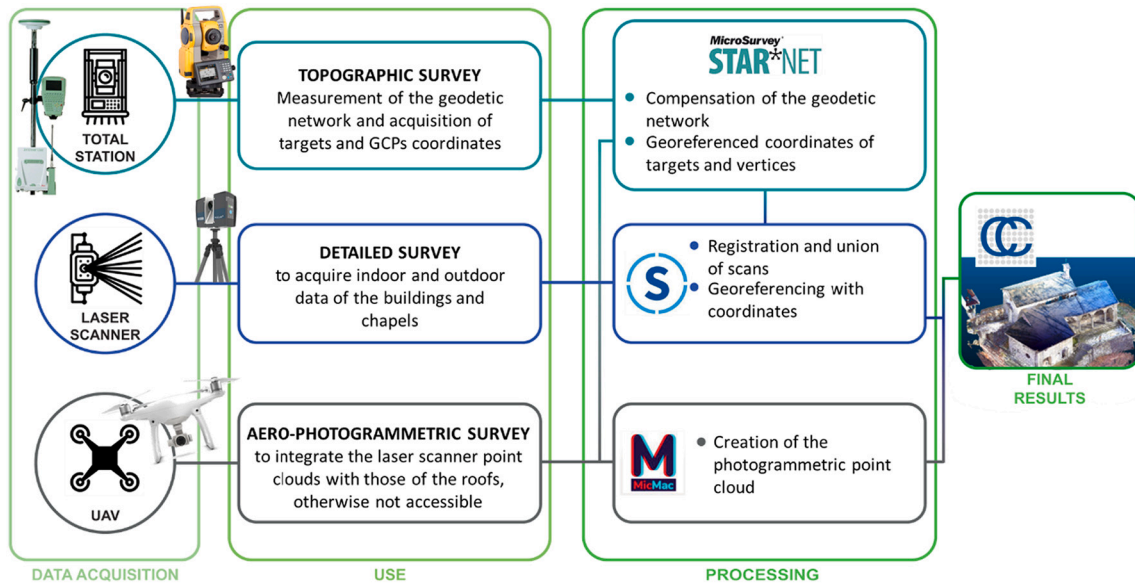

Fig. 3. Integrated metric survey workflow.

that, cleaning, filtering and merging operations were carried out, resulting in a point cloud of about 8 million total points (Fig. 5c). The filtering operation to 1 cm (space-based method) was primarily necessary to facilitate their management in the subsequent phases of modelling in the object-oriented software, maintaining at the same time the accuracy required by the final representation scale.

The last step, before the geometrical definition, was a suitable discretisation of the entire point cloud into topological sub-regions having an extension readable by the Revit software. For this purpose, ReCap360 PRO was used, through which it was possible to divide the point cloud into seven groups (surrounding context, chapels 2, 3 and 4, connecting corridor, columns and a further indoor space anciently depicting the Jerusalem cave) and 26 sub-regions. They were then exported in .rcs format, easily decoded by the BIM software and used as a reference for modelling single elements of the building.

### 2.3. Conversion of geometry for HBIM

After the processing of point clouds, the creation of the HBIM model aimed at the study and analysis of structural elements, started from the choice of a “structural” modelling template. The modelling strategy did not give priority to a detailed representation of architectural elements to obtain a high level of fidelity but to the reproduction, as faithfully as possible, of only the strictly functional structural elements. For this reason, the geometries of terrain (Fig. 6a), walls, wooden beams (Fig. 6b), stone columns and separation walls have been reproduced, leaving out the detailed representation of capitals, mouldings and wooden or glassy diaphragms. Specifically, the terrain has been created through the “topographic surface” based on the point cloud .txt file; the walls, roofs, columns, pillars, beams, stairs, floors and floors in contact with the ground have been modelled using the predefined “system families”; while the vaults through the “local model - Mass” from imported CAD.

One of the main issues encountered in the modelling phase was to

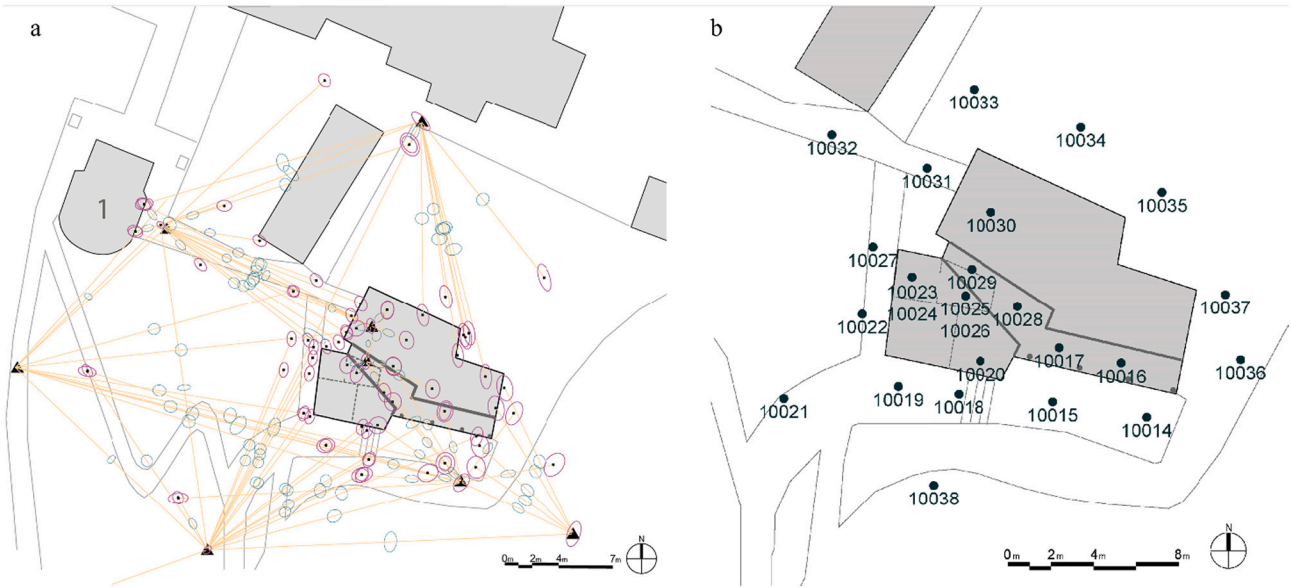

Fig. 4. Top views with the compensation of the geodetic network using STAR\*NET software (highlighted the error ellipses enlarged by a scale factor of 30) (a) and with the location of the laser scans (b).

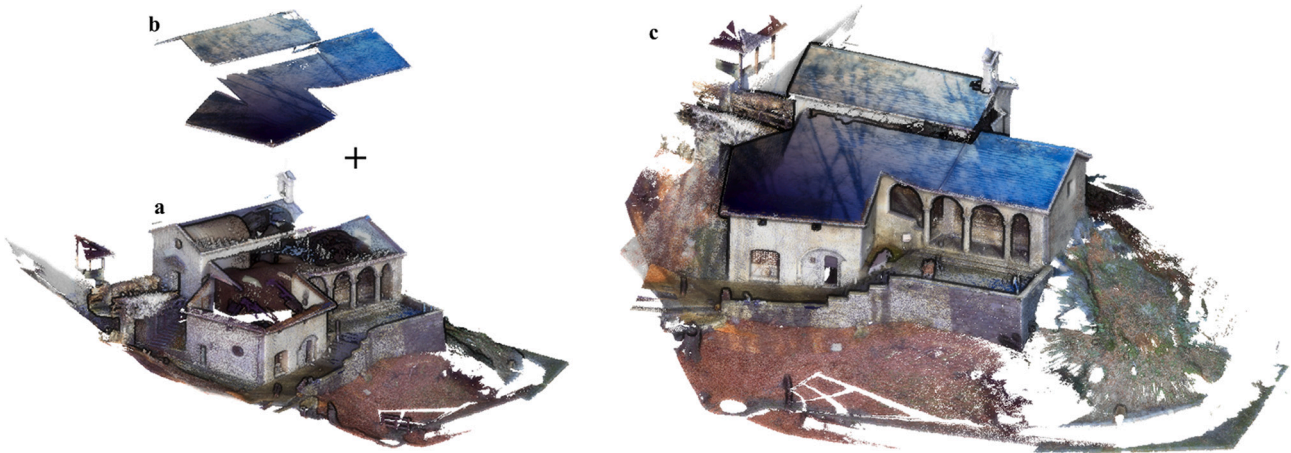

Fig. 5. Results from laser scans (a) and UAV images (b) processing. From the integration of these two point clouds, we obtained an overall point cloud (c) subsequently cleaned and subsampled.

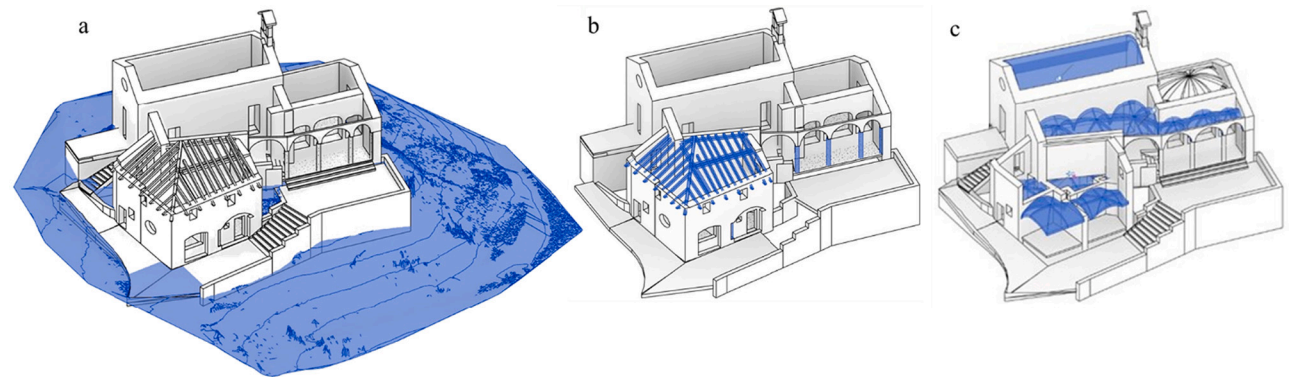

Fig. 6. Overall isometric views of the HBIM model with highlighted the modelling of the topographic surface (a) and the structural components as beams and columns (b) or the whole vaulted system imported from Rhinoceros (c).

represent, only through the Revit software, the structural elements (such as vaults) without oversimplifying them, with the consequent loss of detail of the irregular parts. As already stated in the literature [47], the modelling tools included in the object-oriented software were found to be inadequate when there is a need to represent geometrically complex elements. In our case, it was possible to test three different strategies for these elements: i) creating adaptive parametric families, not the best solution due to the high geometric irregularity of the elements; ii) using the “wall/floor by surface” command based on a specially modelled “mass” element; iii) taking advantage from a third party software specifically aimed at modelling any kind of geometries. The second case was the closest to the intended purpose, but the issue was the inability of the Revit software to manage a vault as a stand-alone typological element, namely a component not attributable to a geometric element with a simple planar development but constituted by a three-dimensional extension and having at the same time a structural function.

To overcome this issue, the potential offered by Rhinoceros 5 software was exploited, making it possible to delineate the profiles of complex geometries with vectors (Fig. 6c).

This software has proved to be very useful as it can be used both for Boolean modelling (operating with simple extrusions or rotations around generative axes) and, above all, for the generation of NURBS (Non-Uniform Rational Basis-Splines) [48,49]. With NURBS surface, a mathematical-based representation, it is possible to accurately define all those geometrical entities with a complex shape, using lines and control points defined directly from the point clouds. It was, therefore, possible to outline and reproduce all the useful profiles for the geometric definition of the intrados of the vaults, with the relative edges generated by the intersection of the individual ribs. From these profiles, it is possible to generate NURBS surfaces passing perfectly through these polylines, obtaining a continuous geometric surface to be easily used for our purposes (Fig. 7).

Using this technique, we could faithfully and effectively reproduce the state of the surfaces of all the vaulted portions, which are therefore congruent with the reference point cloud. In order to import the geometric objects from the .sat file format to the Revit software, it was necessary to add thickness to the surfaces by operating a vertical extrusion of the entire group of NURBS, obtaining a geometric element entirely representative of the vaulted elements.

#### 2.4. The analytical model for structural purposes

Selecting the *structural model* template in the initial steps, Revit allows to automatically view, adjust and manage a simplified analytical

model. This structural analytical model consists of components that contain all the properties of materials, loads and geometries, constituting the semantic part of the architectural model, and it usually appears as a set of two-dimensional planar surfaces. Objects such as beams, pillars and columns are represented by one-dimensional elements, perfectly aligned with the central axis of the architectural reference component (Fig. 8).

Nevertheless, the analytical model thus obtained is highly incomplete (i.e. lack of description of the vaulted systems or inaccuracy of the nodes) and not sufficiently representative of the real architecture. This significant gap demonstrates how the Revit software, mainly focused on the design of modern structures mostly based on bearing frame, cannot autonomously discretise geometrically complex structures, typical of the CH domain, other than those consisting of linear or planar elements. Hence, an intrinsic limitation of the software is pointed out, not allowing static or dynamic analyses, impossible through plugins or specifically dedicated internal tools. The absence of these architectural elements in the analytical model makes the latter useless within the BIM software.

Considering the case study and assuming the use of the PRO\_SAP® structural software, there would be the possibility of using an IFC 2 × 3 standard file import command. However, it was unfeasible: in fact, a decoding error of the IFC 2 × 3 file was found by the structural software, despite the fact that the exported file contained all the characteristics and information of the HBIM model created in Revit. This further operational limitation inevitably implies an adaptation of the simplified structural analytical model by exporting the geometry itself, in .dxf format, to implement it for the use in FEAs.

As shown in Fig. 9a, the .dxf file exported from Revit consists of mesh surfaces, which is fully compatible with the PRO\_SAP® software. Nevertheless, to obtain the final model (Fig. 9b) it was necessary to carry out three main corrective operations:

- the first one was the geometric conversion of the vaults, previously modelled with NURBS, to obtain components consisting of a triangular mesh with a side of at least 15 cm as the likely average size of the vault ashlars. For this operation, the use of GiD 14.1.2d software, specifically dedicated to pre and post-production for finite element numerical simulations in the engineering field, resulted beneficial (Fig. 10). In particular, adjusting the mesh texture is essential to correct the automation process provided by Rhinoceros software for converting NURBS surface to mesh. Rhinoceros has intrinsic criticalities at the mesh level: in the case of conversion from NURBS to triangular mesh, there is the risk of obtaining a mesh texture with non-homologous and coincident vertices, as happened here. For this

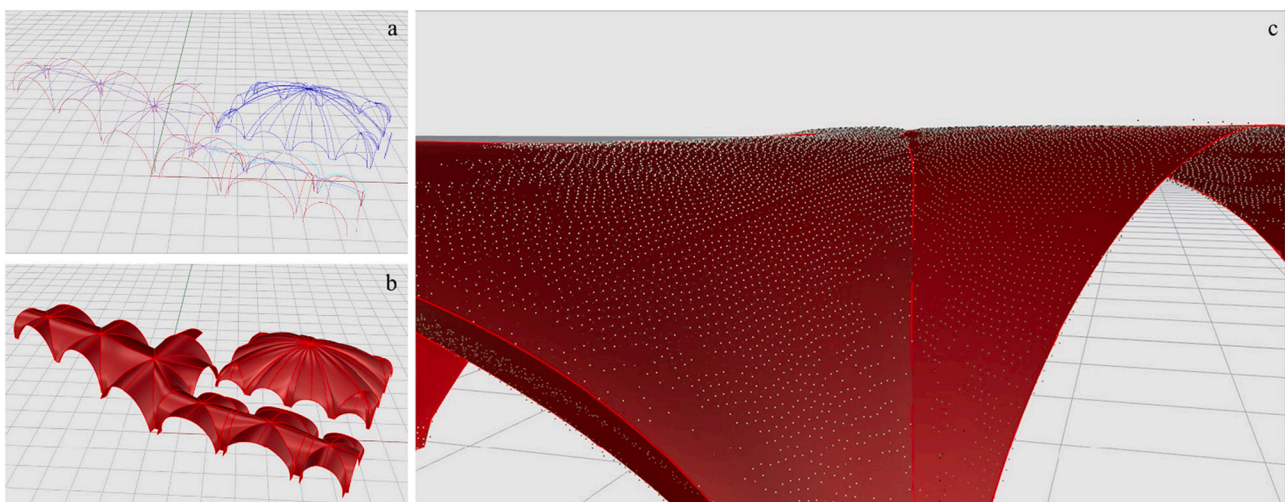

Fig. 7. Modelling phase of the vaults in Rhinoceros 5 through the identification of notable profiles (a) and the consequent generation of NURBS surfaces (b). Representative detail of the performance of NURBS surfaces in relation to vault point cloud (c).

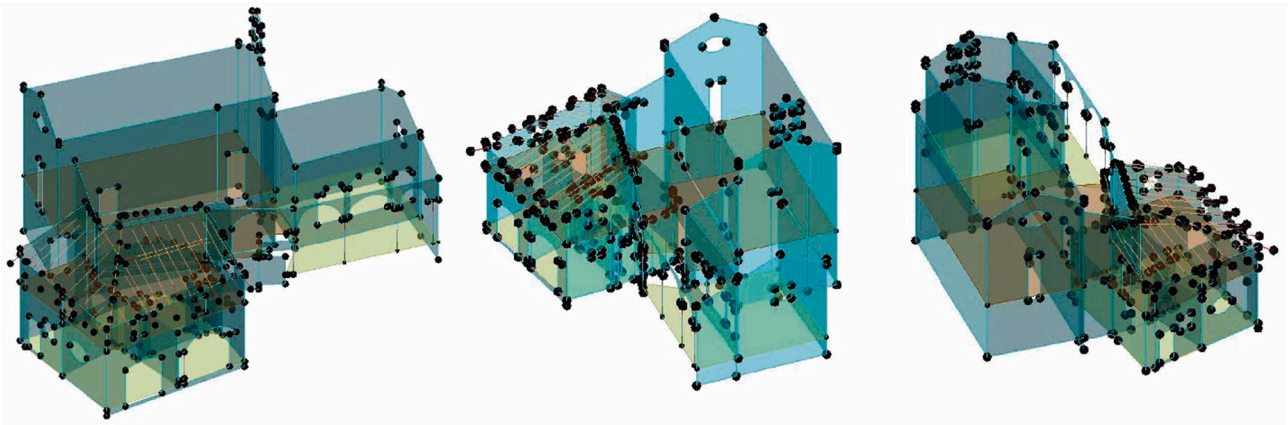

Fig. 8. Isometric view of the analytical model automatically generated from the architectural one within Revit software.

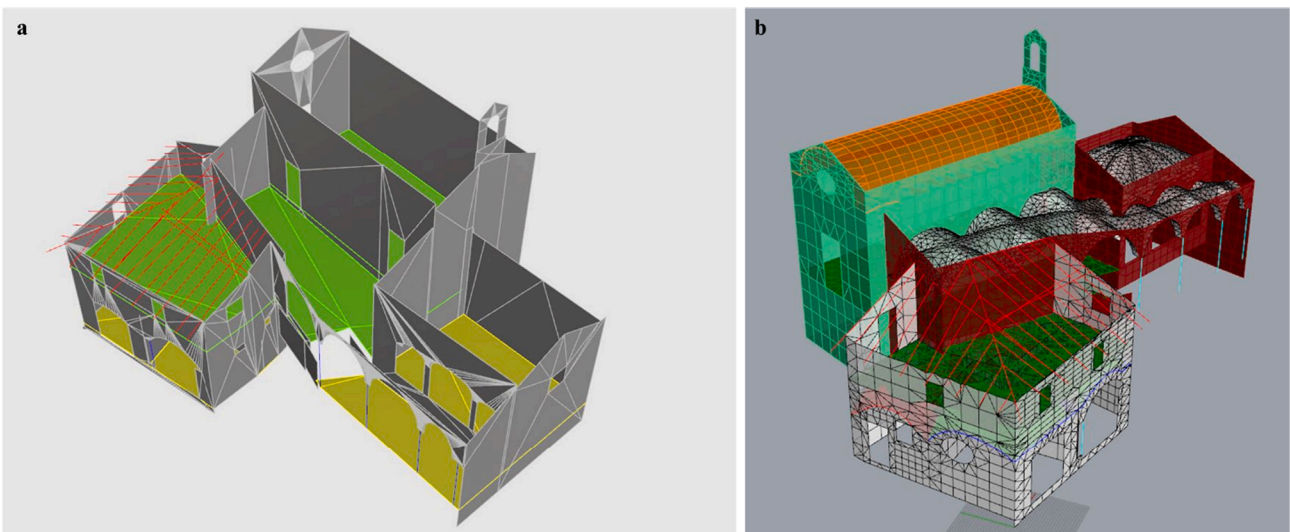

Fig. 9. View of the analytical model obtained by Revit after importing into Rhinoceros (a) and implemented with the correction of the mesh (b).

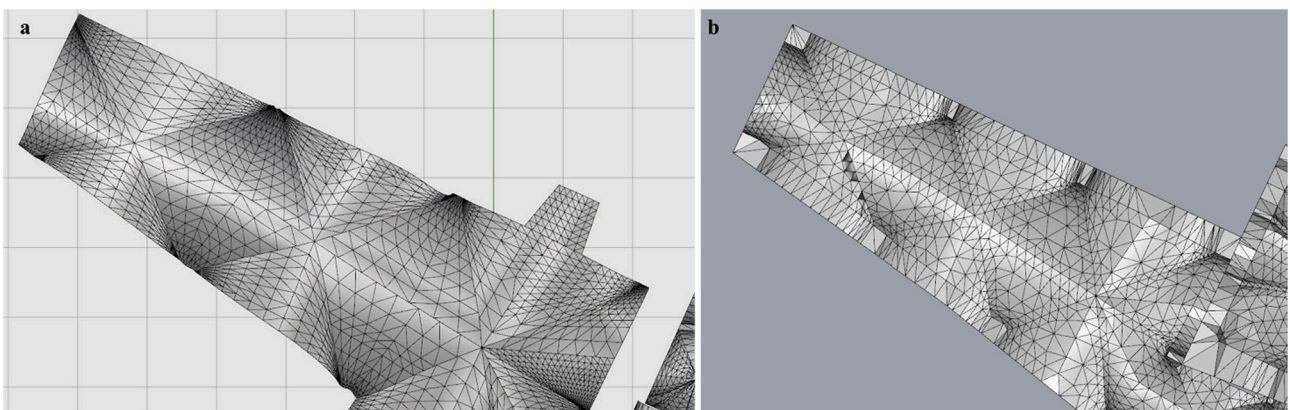

Fig. 10. Comparison between the mesh obtained automatically by Rhinoceros (a) and the one obtained through the use of the GiD software (b). From the image it is possible to see how the nodes of the single mesh faces have been made homologous in the second option and the trend itself has been corrected in order to become denser in the points of maximum curvature and junction of the starting surfaces. This construction of the mesh obtained is thus sufficiently detailed for representative purposes and sufficiently large not to generate possible errors in the FEM analysis phase.

reason, GiD software (widely used in the engineering field for the mesh control process according to FEA analyses) has been chosen;

- in the next step, the intersection of the individual nodes, which must have a unique coincidence to allow an appropriate load transfer in the FEA analysis, was checked;

- finally, the change on vertical surfaces from a triangular to a quadrangular mesh has been carried out in order to have a more regular computation.

The abovementioned operations were performed based on the features that the analytical model must have to obtain an exhaustive FEM analysis, following the guidelines described in the PRO\_SAP® user manual [43]. In particular: the nodes must have a unique coincidence, especially at the points of intersection between the different architectural elements; the planar surfaces must be quadrangular elements with a side preferably between 50 and 80 cm and the curved surfaces (or the members with curvilinear portions) must consist of elements of 15 cm per side as a minimum triangulation dimension, to avoid any errors in the subsequent simulation phases.

### 3. Results and discussions

#### 3.1. Structure simulation with finite element modelling (FEM)

In the previous paragraphs, it was shown how PRO\_SAP® has tools capable of communicating with the BIM domain through the IFC standard, but these functions are not able to satisfy the model interchange between Revit and the designated structural software. This error highlights the need for a software or an algorithm capable of converting a complex object created in a BIM environment into a mesh compatible with the finite element analysis. Without the development of such tool, it is currently impossible to translate it without manual corrections of the geometry. For this lack of interchange, it was therefore necessary to create the structural analytical model directly within PRO\_SAP®, based on the geometry exported from the Revit software and subsequently integrated into Rhinoceros.

By exploiting the equilibrium conditions between internal and external stresses in the single nodes of the mesh, it is possible to find the global response of the structural model to external stress actions, imposing the conditions of congruence of the deformations of the individual finite elements. An approach of this type requires a simplification of the structure into one-dimensional (named D2 in PRO\_SAP®) and planar elements (defined as D3 of *Shell* type). For every single mesh and component, both D3 and D2, it has been necessary to re-attribue the properties of the materials, thicknesses, verification criteria as well as the external constraint conditions, reducing and modifying the degrees of freedom in specific points to reproduce the realistic constraint conditions (Fig. 11).

After completing the operations of importing and checking the geometric data, the PRO\_SAP® software sets up the *verification boundary conditions*. The structural model is composed by shell element with five degrees of freedom: three translations and two rotations in the plane of the element. Stiffness was defined in the plane (membranous) and out of the plane (bending). The material properties and structural geometric characteristics of the model are associated with the elements, as the wall thickness. Regarding the thicknesses of the walls, they are of variable sections, especially according to their position and function, although they follow a sufficiently constant vertical section. They range from approximately 30 cm for some external non-load-bearing walls, up to 100 cm in some load-bearing sections in the lower levels.

The average of the thickness of the walls is around 65 cm, therefore, it is compatible with the use of shell modelling, falling within the average of those cases normally evaluated with shell elements. It is essential to underline that to perform the assessments (static and seismic), in accordance with the Italian technical regulations (NTC 2018), the model must be built only by shell, since with the solid elements the PRO\_SAP® software can only perform the stress and deformations analyses.

Once the mesh and elastic characteristics of the system have been defined, it is possible to simulate the real structural conditions, applying various load and boundary conditions to the model. In our case, through

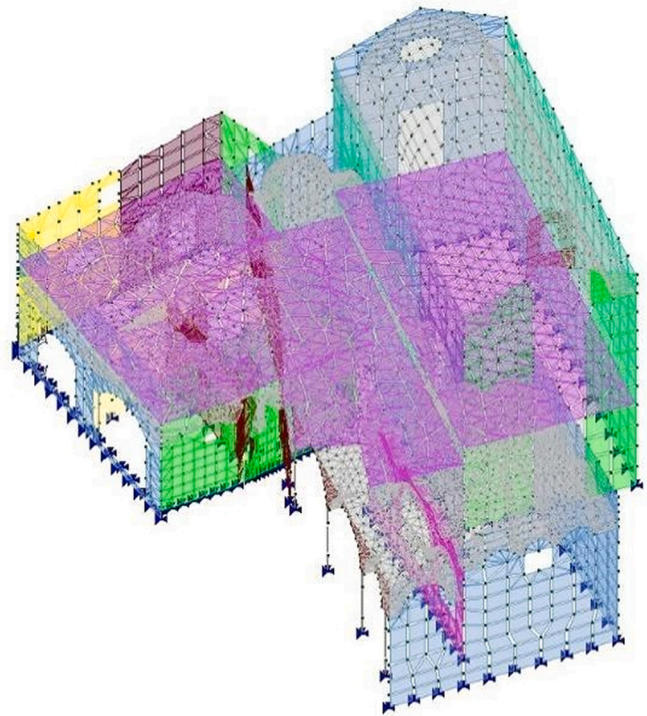

Fig. 11. Structural analytical finite element model, correctly imported and set up. It is depicted a general view of the analytical model used in PRO\_SAP®, based on the geometry exported from Revit and manually edited and corrected in Rhino. The image shows the whole model set in the mechanical properties of elements D2 and D3 and the related external constraint conditions (at the base).

the *Load Assignment* tool, all parameters relating to the Actions on constructions were entered and managed (Ministerial Decree 17/01/2018 [44], par. 2.5 and chapter 3), allowing the insertion of static and dynamic actions. Permanent and variable loads (wind, snow and maintenance overload on the roof) have been defined with reference to Zone 1 - Alpine, in addition to those of a seismic nature.

Through the definitions of the Ministerial Decree about seismic actions, the parameters of the relevant area refer to a building of class III (for buildings with higher crowding than residential buildings and with artistic and historical relevance), with soil category A (outcropping rock masses) and topographical category T2 (top of the slope). Considering the site coordinates, a nominal life  $V_n$  of 50 years, an  $ag_S$  (ground acceleration value depending on the soil category) value for a Lifesaving Limit State (LLS) equal to 0.065 g (gravity) with limited knowledge level (LC1) and a confidence factor  $FC$  equal to 1.35 were defined.

Being a heritage building, it was not possible to perform invasive diagnostic tests for the mechanical characterisation of the walls. Therefore the structural model was based on the minimum mechanical characteristics offered by the table C.8.5.I in technical Italian codes [45], such as minimum values of compression and shear strength, elastic modulus. In this case the masonry texture is considered as “split stone masonry with good texture” with compression strength of 2.6 MPa, shear strength of 0.056 MPa, elastic modulus of 1740 MPa, shear modulus of 580 MPa. As required by the same technical Italian codes, these values have been divided by the safety coefficient of the masonry and by a further coefficient that takes into account the level of depth of the diagnostic campaign. The value of the friction coefficient is that required by the Italian technical standard, equal to 0.4. Several studies carried out by the authors [50] on stone wall textures of the same type are showing similar coefficient of friction values, depending on the level of static load that stresses the wall. The program facilitates these operations by autonomously managing the prescriptions of the Italian

legislation, interpolating them with the physical characteristics of the modelled elements by referring to homogeneous type load files deriving from geometry and materials. In this regard, through these automated procedures, it was possible to define a structure factor  $q$ , which takes into account the ductile response, equal to 1.875 for the X and Y directions, and  $q = 1.5$  in the Z direction, while a value of 5 was used for the damping coefficient of 5%.

Concerning the case study, it was decided to carry out a linear modal

dynamic limit state analysis considering 18 ways of vibrating, since religious buildings do not have a regular geometry to allow us to hypothesise their perfect box-like behaviour. Below (Fig. 12) are presented the local deformation values, expressed in a chromatic scale from blue (minimum value) to red (maximum value). ULS (Ultimate Limit State) is here intended for the heavier combination of the sole static actions prescribed by NTC18 (Fig. 12a). For the most significant ways of vibrating the seismic combinations proposed in the figure, however, it is

a) SLU Combination, Max: 0.95 cm - Min: 0 cm

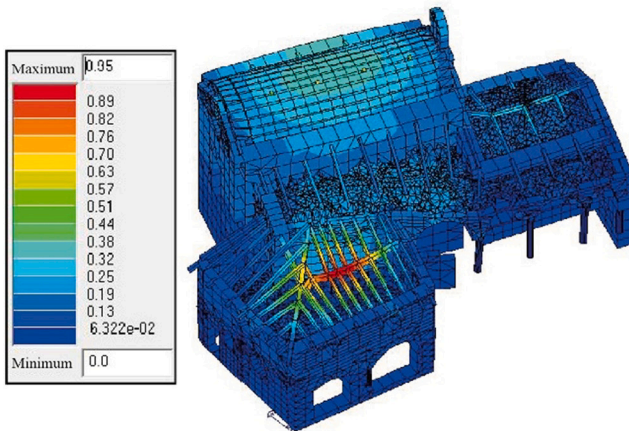

b) Dynamic combination 6, Mode 1, Freq.=5.36 [Hz] and T=0.19[s]

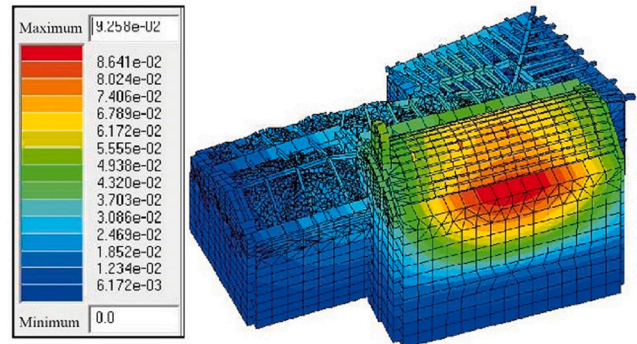

c) Dynamic combination 6, Mode 7, Freq.= 11.19[Hz] and T=8.936e-02[s]

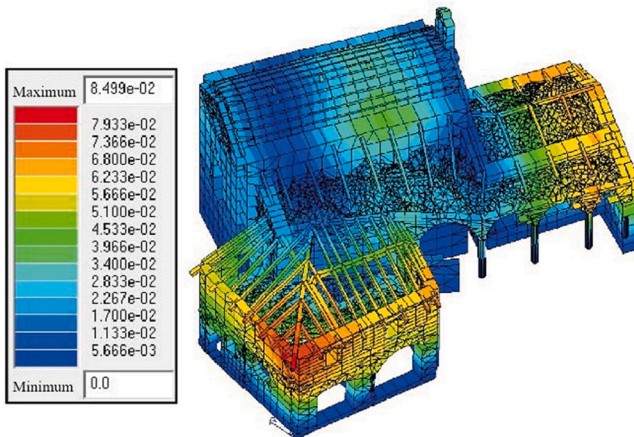

d) Dynamic combination 6, Mode 10, Freq.= 13.95[Hz] and T=7.169e-02[s]

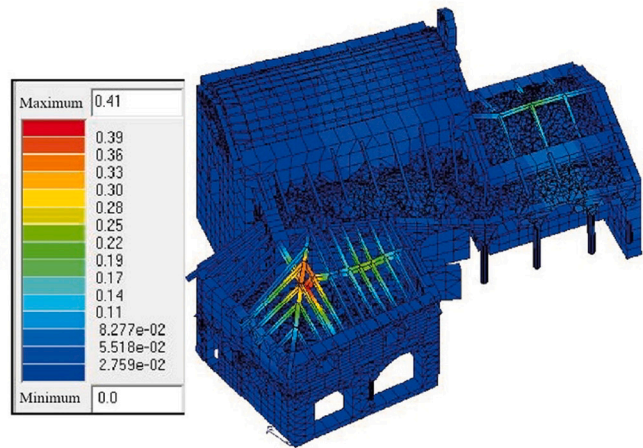

e) Dynamic combination 6, Mode 12, Freq.= 18.09[Hz] and T=5.527e-02[s]

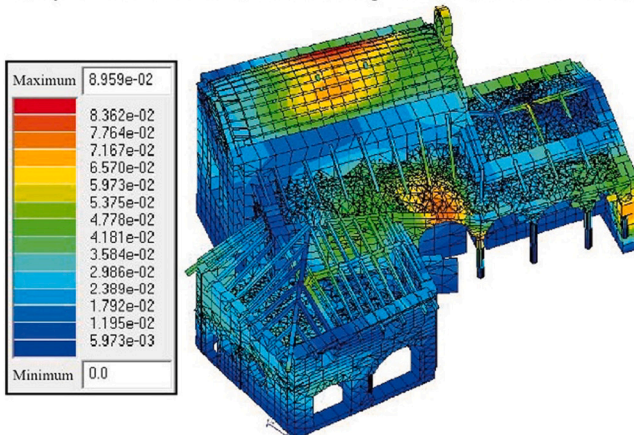

**Fig. 12.** Examples of results obtained in terms of deformation: maximum deformation corresponding to the static combination at Ultimate Limit State (ULS) (a). Most significant deformations deriving from the modes of vibrations for the seismic combinations (b, c, d, e).

possible to notice that there are cases of maximum deformation in the different modes of vibration that alternatively affect both the roof structure (Fig. 12d) and the upper part of the wall on which it leans (Fig. 12b, c and e). The maximum stress on the roof, obtained both from the ULS combination and from the seismic combinations, is consistent with the anomalous configuration of the main roof structure. This covering system has been the subject of an extraordinary maintenance intervention, which changed the load-bearing elements according to a non-optimal scheme, not respecting the previous disposition (Fig. 13d). This uncorrected structural intervention could lead to anomalous local deformations, consistent with the results highlighted by the analysis of the current state.

Regarding the constraint conditions, since it is an existing building without foundation subsidence, starting from the assumption that the soil-foundation interaction has been balanced for a long time, the base is sufficient for the translations only, leaving the rotations free, as also required and recommended by the manual of the software.

### 3.2. Discussions on the results of the FE analyses

As it can be seen from the previous images, the analytical model is aligned with the effective structural situation of the building, as it reproduces the accumulation of tension in the identical points where the real structure shows signs of failure. As regards the tensions, the most stressed areas correspond to the supports of the floors and roofs, but also the base of the principal masonry walls, as well as the points of junction with the vaults: these results allow to deduce that the constraint conditions imposed at the base of the walls and, more generally, in the whole model return a likely behaviour of the entire complex structure. On the other hand, analysing the results in terms of deformation, it is evident that in none of the reported cases, in combination of seismic load both at the LLS and ULS, the maximum deformation value exceeds the order of magnitude of the centimetre. The maximum local deformation value of 0.95 cm is shown at the roof beams of chapel 4 with the combination at ULS A1 3 (Fig. 12a). The latter is the name of the heavier combination given by PRO\_SAP® when performing the analysis; it is a numerical notation of the load combinations dictated by the Technical Standards.

The result can be considered plausible as the wood has greater elastic characteristics than the existing masonry; moreover, in the same point, during the survey campaign, an assembly error of the roof beams (committed during an extraordinary maintenance work carried out in previous years) was identified. Therefore, this result indicates that, in this portion of the building, it is necessary to go through a timely decisive intervention. By globally analysing the results obtained in terms of deformation, it is possible to clearly and accurately identify the portions of the building requiring consolidation operations (Fig. 13), to avoid possible crisis phenomena in the vaults or the overturning mechanisms found in some masonry walls.

### 3.3. Structural verification

The performance of the analytical model, simulated relatively to the characteristics of resistance and efficiency required by the Italian legislation, have been afterwards verified. For existing masonry buildings, as in our case, the assessment of the overall safety must be carried out in relation to the collapse mechanisms, both in local and global terms when the latter are significant. In this case, the verification was conducted by referring to the data obtained through linear dynamic analysis. A reliable attribution of materials to the elements of the model plays a fundamental role for the success of the simulation, as well as the correct definition of the mechanical performances of the walls or their related specifications (e.g. materials composition).

Since from the survey phases, it was not possible to obtain sufficiently accurate data for the definition of the performance characteristics of the masonry, in the structural model the selection of materials suitable for the real architecture was carried out through the PRO\_SAP® default parameters: i.e. stone and mortar masonry was assumed for the walls. Once the calculation was completed, it was possible to obtain a series of results related to the various structural elements. The results of the assessments are presented (Fig. 14) in a very simple and intuitive way, based on a colour scale for every single D3 element: blue for elements verified with another criterion; yellow for not designed parts; cyan for verified elements and red for not verified components.

Analysing the images it is possible to notice that the structure has widespread criticalities, showing numerous inefficiencies of the walls

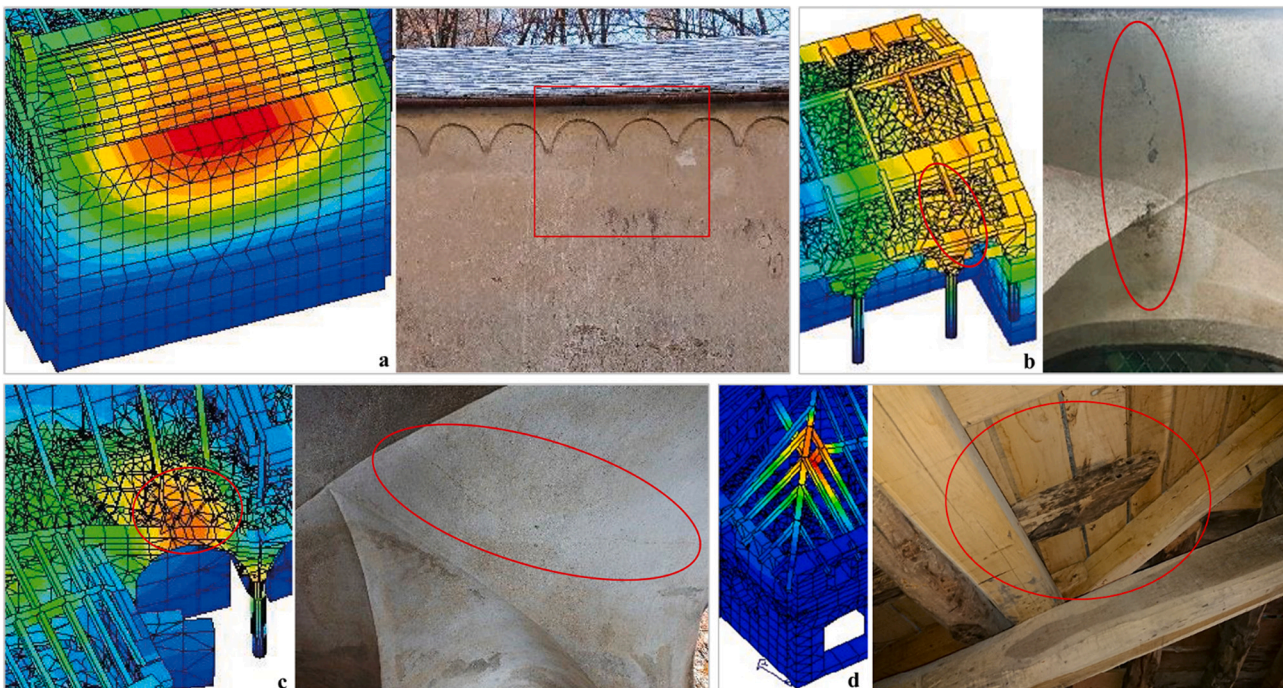
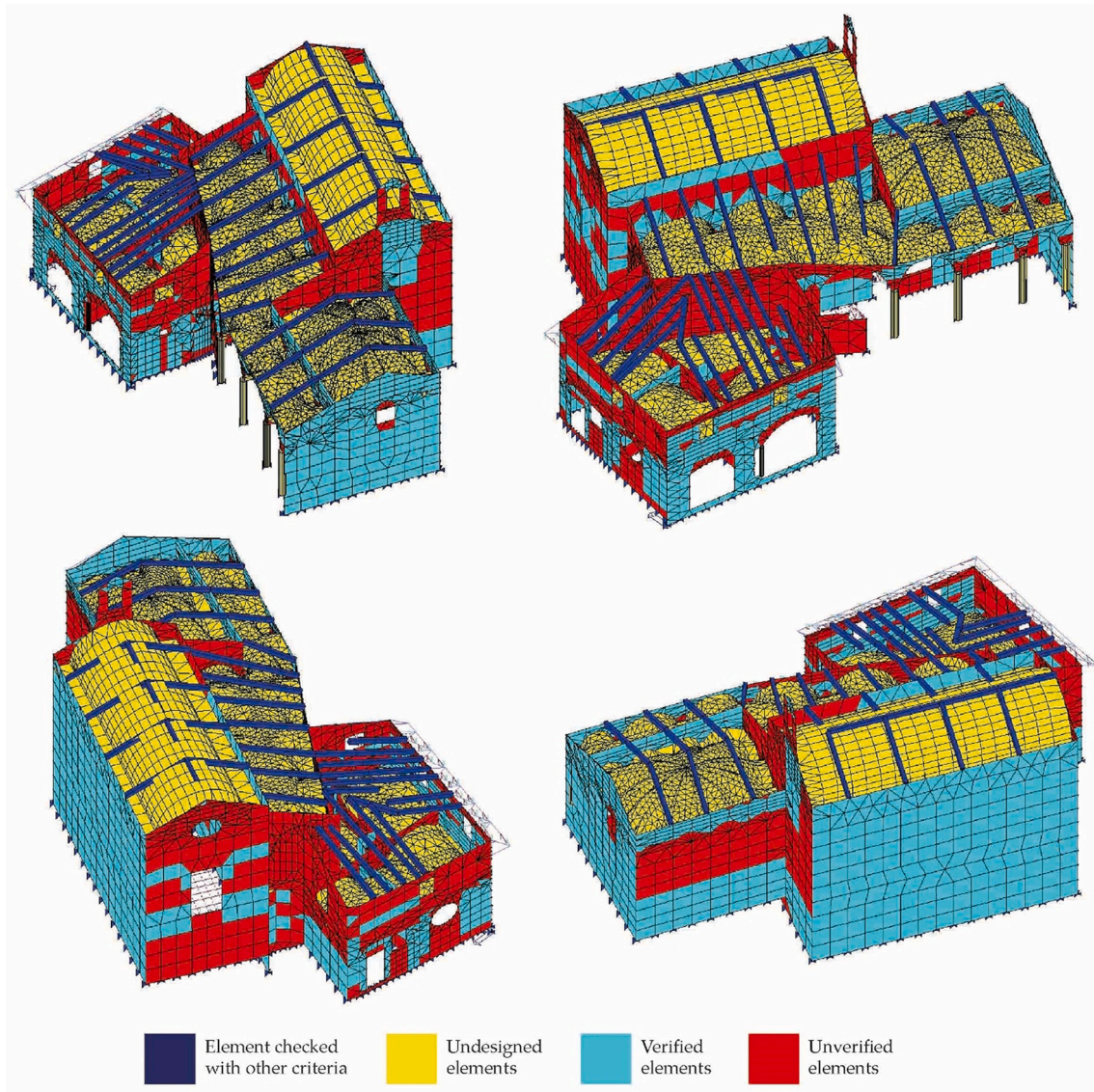

Fig. 13. Comparison between analytical models and damages on wall structures on Chapel 2 (fractures on stone masonries and vaults).



**Fig. 14.** Results in chromatic scale of the verifications performed only on the masonry components by analysing out-of-plane, in-plane and shear bending (chapter 7.8.2.2.3 NTC 2018) at 10% of Peak Ground Acceleration (PGA). The portions of mesh marked in red represent the parts of the structure that have not passed the resistance test and for which it is necessary to carry out analyses and local improvement interventions. (For interpretation of the references to colour in this figure legend, the reader is referred to the web version of this article.)

even with a ground acceleration value equal to 10% of the design value (no vault has been verified for the reasons described in paragraph 3.2. Furthermore, considering the results, every single chapel would probably suffer serious damages, as it can be expected for a structure of this historical period and construction technique. There is, in fact, a concentration of unverified elements, especially in the portions of the building with strong geometric discontinuity and in the upper and lower bands of the openings.

Broadly speaking, the positive outcome of this assessment confirms and consolidates the usefulness of an operating procedure through which it is possible to:

- identify and precisely define all the architectural and structural elements that must be verified,
- establish which ones may be subject to structural improvement in future maintenance plans and seismic safety assessments.

However, it must be pointed out that, before any intervention, it is necessary to increase the level of knowledge, operating on the building

with local analyses and punctual investigations, to define more accurately the constitutive and performance characteristics of the materials and their mechanical behaviour, obtaining a better overall confidence factor of the masonry members.

#### 4. Conclusions

Through operations of selection, conversion and exchange of information between the various software, it has been possible to generate a 3D parametric model, exploiting the HBIM modelling technologies with the Autodesk Revit Architecture software. In this way, it was also possible to combine all the information of geometric nature, with all the material and typological features detected visually and rapidly during the survey campaign. The intertwining of these aspects has allowed the reproduction in a virtual environment of the building, obtaining an adequate, versatile and functional result for all future operations. Through precise conversion steps, the three-dimensional object processed with the BIM methodology was converted into a simplified analytical model, in order to exploit it with structural purposes, using

the PRO\_SAP® software. Through these analyses, it was possible to deduce the current performance characteristics, useful for setting the basis of any consolidation or structural improvement interventions in support of a more suitable safeguard of the architectural asset (with a consequent step towards higher levels of safety). In addition, the analyses were not performed on a dedicated workstation, but on a personal notebook (Asus N751JX-T4023H with Intel® Core™ i7-4720HQ processor and 16GB DDR3L at 1600 MHz RAM), taking approximately 45/60 min of processing by PRO\_SAP® software alone. This element confirms the potential of the proposed methodology, given that even with a non-performing PC the calculation times are reduced and easily manageable.

Despite the strong technological innovation and considering the growing need for data sharing between the various professional figures and stakeholders involved, some issues still remain in the proposed workflow:

- very long post-processing times compared to relatively short data acquisition times;
- lack of precision in some of the modelling operations in the BIM environment;
- inconsistencies and inaccuracies in the phases of interchange between BIM software and FEA software, with no interchange via IFC format;
- gaps of Autodesk Revit in the representation of historical masonries. The software is unable to autonomously discretise geometrically complex structures except for those constituted by linear or planar elements.

The lack of recognition of complex elements is a strong limitation for the HBIM models, especially for structural safety assessments, as any kind of vault in historical architecture is, at the same time, both a spatial architectural element and a structural element with function of connecting or transferring of loads from horizontal surfaces to walls or columns.

In spite of these issues and the involvement of numerous software, it was demonstrated how to recreate from the point cloud not only an HBIM model but also the subsequent structural analytical model, representative of the current state of the Nazareth complex, exploiting the HBIM itself. With this process, it was thus possible to faithfully reproduce the complex geometries (in particular vaults and roofs) constituting the main criticality of today's three-dimensional representation techniques. Furthermore, by exploiting the software great data processing capabilities, the attribution to the geometric model and evaluation (as a hypothesis) of the mechanical and dynamic nature of the materials was also carried out, obtaining very useful and reliable results based on the state of the building and the boundary conditions.

In conclusion, it is therefore possible to state that the proposed workflow offers a starting point for interesting applications, not only strictly related to the structural context but also, and above all, in relation to the management, conservation and maintenance of the existing architectural heritage, through workflows deriving from HBIM methodologies. In fact, with these resources, the research group has defined a programmed maintenance plan (in synergy with the Sacri Monti Management Body) within the Italy-Switzerland Interreg "MAIN10ANCE" Project and it is currently implementing it.

A future perspective of this work is the implementation of a dynamic operational analysis of the building to confirm the results of our modal analysis.

#### Declaration of Competing Interest

The authors declare that they have no known competing financial interests or personal relationships that could have appeared to influence the work reported in this paper.

#### Data availability

Data will be made available on request.

#### Acknowledgements

The authors would like to acknowledge the MAIN10ANCE project (ID 473472) funded by the European Regional Development Fund (ERDF), Axis 2 - Enhancement of the natural and cultural heritage. In addition, they would like to thank Dr. Elena De Filippis, Past Director of the Management Body of Sacri Monti, as well as the personnel of the site and the professor Andrea Lingua that allowed and supervised the surveying activities.

#### References

- [1] A. Grazzini, F. Chiabrando, S. Foti, G. Sammartano, A. Spanò, A multidisciplinary study on the seismic vulnerability of St. Agostino church in Amatrice following the 2016 seismic sequence, *Int J. Architect. Heritage* (2019) 1–18, <https://doi.org/10.1080/15583058.2019.1575929>.
- [2] A. Grazzini, S. Fasana, M. Zerbinatti, G. Lacidogna, Non-destructive tests for damage evaluation of stone columns: the case study of Sacro Monte in Ghiffa (Italy), *Appl. Sci.* 10 (2020) 1–15, <https://doi.org/10.3390/app10082673>.
- [3] M. Zerbinatti, F. Matrone, A. Lingua, Planned maintenance for architectural heritage. Experiences in progress from 3D survey to intervention programmes through HBIM, *TEMA – Technol. Eng. Mater. Architect.* 7 (1) (2021) 32–42, <https://doi.org/10.30682/tema0701d>.
- [4] A. Grazzini, G. Lacidogna, S. Valente, F. Accornero, Delamination of plasters applied to historical masonry walls: analysis by acoustic emission technique and numerical model, in: *IOP Conf. Series: Material Science and Engineering* 372, 2018, pp. 1–7, <https://doi.org/10.1088/1757-899X/372/1/012022>.
- [5] F. Chiabrando, G. Sammartano, A. Spanò, A. Spreafico, Hybrid 3D models: when geomatics innovations meet extensive built heritage complexes, *ISPRS Int. J. Geo Inf.* 8 (3) (2019) 124, <https://doi.org/10.3390/ijgi8030124>.
- [6] G. Tucci, V. Bonora, A. Conti, L. Fiorini, Digital workflow for the acquisition and elaboration of 3D data in a monumental complex: the fortress of Saint John the Baptist in Florence, in: *ISPRS - International Archives of Photogrammetry Remote Sensing and Spatial Information Sciences XLII-2/W5*, 2017, pp. 679–686.
- [7] G. Bitelli, M. Dellapasqua, V.A. Girelli, E. Sanchini, M.A. Tini, 3D geomatics techniques for an integrated approach to cultural heritage knowledge: the case of san Michele in Acerboli's Church in Santarcangelo di Romagna, in: *ISPRS - International Archives of Photogrammetry Remote Sensing and Spatial Information Sciences XLII-5/W1*, 2017, pp. 291–296, <https://doi.org/10.5194/isprs-archives-XLII-5-W1-291-2017>.
- [8] M. Murphy, E. McGovern, S. Pavia, Historic building information modelling (HBIM), *Struct. Surv.* 27 (4) (2009) 311–327, <https://doi.org/10.1108/02630800910985108>.
- [9] R. Volk, J. Stengel, F. Schultmann, Building information models (BIM) for existing buildings – literature review and future needs, *Autom. Constr.* 38 (2014) 109–127, <https://doi.org/10.1016/j.autcon.2013.10.023>.
- [10] C. Dore, M. Murphy, Current state of the art historic building information modelling, in: *ISPRS - International Archives of Photogrammetry Remote Sensing and Spatial Information Sciences XLII-2/W5*, 2017, pp. 185–192, <https://doi.org/10.5194/isprs-archives-XLII-2-W5-185-2017>.
- [11] R. Brumana, A. Georgopoulos, D. Oreni, A. Raimondi, A. Bregianni, HBIM for documentation, dissemination and management of built heritage. The case study of St. Maria in Scaria d'Intelvi, *Int. J. Heritage Digital Era* 2 (3) (2013) 433–451, <https://doi.org/10.1260/2047-4970.2.3.433>.
- [12] R. Quattrini, E.S. Malinverni, P. Cini, R. Nespeca, Orlietti, From TLS to HBIM. High quality semantically-aware 3D modeling of complex architecture, in: *ISPRS - International Archives of Photogrammetry Remote Sensing and Spatial Information Sciences*, Avila, Spain, XL-5/W4, 2015, pp. 367–374, <https://doi.org/10.5194/isprsarchives-XL-5-W4-367-2015>.
- [13] F. Chiabrando, G. Sammartano, A.T. Spanò, Historical building models and their handling via 3D survey: From points clouds to user-oriented HBIM, in: *ISPRS - International Archives of Photogrammetry Remote Sensing and Spatial Information Sciences*, XLI-B5, 2016, pp. 633–640, <https://doi.org/10.5194/ISPRS-ARCHIVES-XLI-B5-633-2016>.
- [14] L. Inzerillo, M. Lo Turco, S. Parrinello, C. Santagati, G.M. Valenti, BIM e beni architettonici: verso una metodologia operativa per la conoscenza e gestione del patrimonio culturale (BIM and architectural heritage: towards an operational methodology for the knowledge and management of cultural heritage), *Disegnare Con, Le dimensioni del BIM* 9 (16) (2016) 161–169 (ISSN 1828-5961).
- [15] L. Fregonese, L. Taffurelli, A. Adami, S. Chiarini, S. Cremonesi, J. Helder, A. Spezzoni, Survey and modelling for the BIM of Basilica of San Marco in Venice, 2017, in: *ISPRS - International Archives of Photogrammetry Remote Sensing and Spatial Information Sciences*, XLII-2/W3, 2017, pp. 303–310, <https://doi.org/10.5194/isprs-archives-XLII-2-W3-303-2017>.
- [16] F. Banfi, L. Chow, M. Reina Ortiz, C. Ouimet, S. Fai, Building information modeling for cultural heritage: The management of generative process for complex historical buildings, in: M. Ioannides (Ed.), *Digital Cultural Heritage. Lecture Notes in*

- Computer Science vol. 10605, Springer, 2018, pp. 119–130, [https://doi.org/10.1007/978-3-319-75826-8\\_10](https://doi.org/10.1007/978-3-319-75826-8_10).
- [17] P. Martínez-Carricondo, F. Carvajal-Ramírez, L. Yero-Paneque, F. Agüera-Vega, Combination of nadir and oblique UAV photogrammetry and HBIM for the virtual reconstruction of cultural heritage. Case study of Cortijo del Fraile in Níjar, Almería (Spain), *Build. Res. Inf.* 48 (2) (2020) 140–159, <https://doi.org/10.1080/09613218.2019.1626213>.
- [18] A. Osello, G. Lucibello, F. Morgagni, HBIM and virtual tools: a new chance to preserve architectural heritage, *Buildings* 8 (1) (2018) 12, <https://doi.org/10.3390/buildings8010012>.
- [19] F. Banfi, R. Brumana, C. Stanga, A., Content-based immersive experience of Basilica of Sant' Ambrogio in Milan: From 3D survey to virtual reality, in: *ISPRS - International Archives of Photogrammetry Remote Sensing and Spatial Information Sciences, XLII-2/W11*, 2019, pp. 159–166, <https://doi.org/10.5194/isprs-archives-XLII-2-W11-159-2019>.
- [20] N. Bruno, R. Roncella, A restoration oriented HBIM system for cultural heritage documentation: the case study of Parma cathedral, in: *ISPRS - International Archives of Photogrammetry Remote Sensing and Spatial Information Sciences, XLII-2*, 2018, pp. 171–178, <https://doi.org/10.5194/isprs-archives-XLII-2-171-2018>.
- [21] D. Oreni, R. Brumana, B. Cuca, A. Georgopoulos, HBIM for conservation and management of built heritage: Towards a library of vaults and wooden beam floors, in: *CIPA 2013 XXV International Symposium, ISPRS - Annals of Photogrammetry Remote Sensing and Spatial Information Sciences vol. 164*, 2013, pp. 1–6, <https://doi.org/10.5194/isprsannals-II-5-W1-215-2013>.
- [22] D. Oreni, R. Brumana, S. Della Torre, F. Banfi, L. Barazzetti, M. Previtali, Survey turned into HBIM: the restoration and the work involved concerning the Basilica di Collemaggio after the earthquake (L'Aquila), *ISPRS - Annals of Photogrammetry Remote Sens. Spat. Inform. Sci.* II-5 (2014) 267–273, <https://doi.org/10.5194/isprsannals-II-5-267-2014>.
- [23] F. Chiabrando, M. Lo Turco, F. Rinaudo, Modeling the decay in an HBIM starting from 3D point clouds. A followed approach for cultural heritage knowledge, in: *ISPRS - International Archives of Photogrammetry Remote Sensing and Spatial Information Sciences, XLII-2/W5*, 2017, pp. 605–612, <https://doi.org/10.5194/isprs-archives-XLII-2-W5-605-2017>.
- [24] A. Baik, R. Yaagoubi, J. Boehm, Integration of Jeddah Historical BIM and 3D GIS for documentation and restoration of historical monument, in: *ISPRS - International Archives of Photogrammetry Remote Sensing and Spatial Information Sciences, XL-5/W7*, 2015, pp. 29–34, <https://doi.org/10.5194/isprsarchives-XL-5-W7-29-2015>.
- [25] I. Trizio, F. Savini, A. Giannangeli, R. Boccabella, G. Petrucci, The archaeological analysis of masonry for the restoration project in HBIM, in: *ISPRS - International Archives of Photogrammetry Remote Sensing and Spatial Information Sciences, XLII-2/W9*, 2019, pp. 715–722, <https://doi.org/10.5194/isprs-archives-XLII-2-W9-715-2019>.
- [26] V. Bagnolo, R. Argiolas, A. Cuccu, HBIM for archaeological sites: from SfM based survey to algorithmic modeling, in: *ISPRS - International Archives of Photogrammetry Remote Sensing and Spatial Information Sciences, XLII-2/W9*, 2019, pp. 57–63, <https://doi.org/10.5194/isprs-archives-XLII-2-W9-57-2019>.
- [27] L. Diaz-Vilarino, P. Boguslawski, M. Azenha, L. Mahdjoubi, P.B. Lourenco, P. Arias, From LiDAR data towards HBIM for energy analysis, in: Y. Arayici, J. Counsell, L. Mahdjoubi, G.A. Nagy, S. Hawas, K. Dweidar (Eds.), *Heritage Building Information Modelling*, Routledge Taylor & Francis Group, 2017, pp. 218–223. ISBN 9781138645684.
- [28] F. Matrone, E. Colucci, V. De Ruvo, A. Lingua, A. Spanò, HBIM in a semantic 3D GIS database, in: *ISPRS - International Archives of Photogrammetry Remote Sensing and Spatial Information Sciences, XLII-2/W11*, 2019, pp. 857–865, <https://doi.org/10.5194/isprs-archives-XLII-2-W11-857-2019>.
- [29] E. Colucci, V. De Ruvo, A. Lingua, F. Matrone, G. Rizzo, HBIM-GIS integration: from IFC to CityGML standard for damaged cultural heritage in a multiscale 3D GIS, *Appl. Sci.* 10 (4) (2020) 1356, <https://doi.org/10.3390/app10041356>.
- [30] S. Fai, K. Graham, T. Duckworth, N. Wood, R. Attar, *Building Information Modeling and Heritage Documentation*. CIPA 2011 Conference Proceedings: XXIIIrd International CIPA Symposium, 2011, p. 8. Available at, <https://www.autodesk.com/research/publications/building-information-modeling-and-heritage-documentation>. Last access: 22<sup>nd</sup> July 2022.
- [31] G. Castellazzi, A.M. D'Altri, G. Bitelli, I. Selvaggi, A. Lambertini, From laser scanning to finite element analysis of complex buildings by using a semi-automatic procedure, *Sensors* 15 (2015) 18360–18380, <https://doi.org/10.3390/s150818360>.
- [32] G. Castellazzi, A.M. D'Altri, S. de Miranda, F. Ubertini, An innovative numerical modeling strategy for the structural analysis of historical monumental buildings, *Eng. Struct.* 132 (2017) 229–248, <https://doi.org/10.1016/j.engstruct.2016.11.032>.
- [33] G. Bitelli, G. Castellazzi, A.M. D'Altri, S. de Miranda, A. Lambertini, I. Selvaggi, On the generation of numerical models from point clouds for the analysis of damaged cultural heritage, *IOP Conf. Ser. Mater. Sci. Eng.* 364 (2018) 1–8, <https://doi.org/10.1088/1757-899X/364/1/012083>.
- [34] L. Barazzetti, F. Banfi, R. Brumana, G. Gusmeroli, D. Oreni, M. Previtali, F. Roncoroni, G. Schiantarelli, BIM from laser clouds and finite element analysis: Combining structural analysis and geometric complexity, in: *ISPRS - International Archives of Photogrammetry Remote Sensing and Spatial Information Sciences, XL-5/W4*, 2015, pp. 345–350, <https://doi.org/10.5194/isprsarchives-XL-5-W4-345-2015>.
- [35] L. Barazzetti, F. Banfi, R. Brumana, G. Gusmeroli, M. Previtali, G. Schiantarelli, Cloud-to-BIM-to-FEM: structural simulation with accurate historic BIM from laser scans, *Simul. Model. Pract. Theory* 57 (2015) 71–87, <https://doi.org/10.1016/j.simpat.2015.06.004>.
- [36] C. Dore, M. Murphy, S. McCarthy, F. Brechin, C. Casidy, E. Dirix, Structural simulations and conservation analysis -historic building information model (HBIM), in: *ISPRS - International Archives of Photogrammetry Remote Sensing and Spatial Information Sciences, XL-5/W4*, 2015, pp. 351–357, <https://doi.org/10.5194/isprs-archives-XLII-5-W1-337-2017>.
- [37] M. Pepe, D. Costantino, A. Restuccia Garofalo, An efficient pipeline to obtain 3D model for HBIM and structural analysis purposes from 3D point clouds, *Appl. Sci.* 10 (2020) 1235, <https://doi.org/10.3390/app10041235>.
- [38] S. Bruno, M. De Fino, F. Fatiguso, Historic building information modelling: performance assessment for diagnosis-aided information modelling and management, *Autom. Constr.* 86 (2018) 256–276. ISSN 0926-5805, <https://doi.org/10.1016/j.autcon.2017.11.009>.
- [39] R. Mora, L.J. Sánchez-Aparicio, M.Á. Maté-González, J. García-Álvarez, M. Sánchez-Aparicio, D. González-Aguilera, An historical building information modelling approach for the preventive conservation of historical constructions: application to the historical library of Salamanca, *Autom. Constr.* 121 (2021) 1–22, 103449. ISSN 0926-5805, <https://doi.org/10.1016/j.autcon.2020.103449>.
- [40] E. De Filippis, Guida del Sacro Monte di Varallo (Guide to the Sacro Monte of Varallo), *Tipolitografia di Borgosesia, Borgosesia*, 2009.
- [41] D. Oreni, R. Brumana, F. Banfi, L. Bertola, L. Barazzetti, B. Cuca, M. Previtali, F. Roncoroni, Beyond crude 3D models: from point clouds to historical building information modeling via NURBS, in: *Digital Heritage. Progress in Cultural Heritage: Documentation, Preservation, and Protection vol. 8740*, Springer International Publishing, 2014, pp. 166–175, [https://doi.org/10.1007/978-3-319-13695-0\\_16](https://doi.org/10.1007/978-3-319-13695-0_16).
- [42] O.C. Zienkiewicz, *The Finite Element Method, Engineering Science*, McGraw-Hill, London, 1971. ISBN-13: 978-0070941380.
- [43] PRO\_SAP® Instruction Manual, 2Si, Ferrara (Italy). Last access: 7 December 2020, Available at, <https://www.2si.it/it/download-manuali-ed-esempi/>, 2018. Last Access: 20<sup>th</sup> November 2020.
- [44] D.M. 17/01/2018, Norme Tecniche per le Costruzioni (Technical Standards for Construction) (G.U. n. 42 del 20-2-2018), Italian Ministry of Infrastructure and Transport, Rome, Italy, 2018. Available at, <https://www.gazzettaufficiale.it/eli/gu/2018/02/20/42/so/8/sg/pdf>. Last access: 20<sup>th</sup> November 2020.
- [45] Circolare 21st January 2019 n. 7 "Istruzioni per l'applicazione dell'Aggiornamento delle «Nuove norme tecniche per le costruzioni»" (Instructions for the application of the Update of the «New technical standards for constructions»), Ministerial Decree 17<sup>th</sup> January 2018, (G.U. n. 35 of 11-2-2019 - Suppl. Ordinario n.5), Italian Ministry of Infrastructure and Transport, Rome, Italy, 2019. Available at, <https://www.cneologgi.it/wp-content/uploads/2019/02/Circolare-21-gennaio-2019-n-7.pdf>. Last access: 20<sup>th</sup> November 2020.
- [46] DPCM (Decree of the President of the Council of Ministers) 9<sup>th</sup> February 2011 "Valutazione e riduzione del rischio sismico del patrimonio culturale con riferimento alle norme tecniche per le costruzioni di cui al decreto ministeriale 14 gennaio 2008" (Assessment and reduction of the seismic risk of cultural heritage with reference to the technical standards for buildings referred to in the Ministerial Decree January 14, 2008), Rome, Italy, Available at, <https://www.veneto.benicult.urali.it/sites/default/files/Valutazione%20rischio%20sismico%20-%20Direttiva%20PCM%209%20febbraio%202011.pdf>, 2011. Last access: 22 November 2020.
- [47] F. Banfi, The integration of a scan-to-HBIM process in BIM application: The development of an add-in to guide users in Autodesk Revit, in: *ISPRS - International Archives of Photogrammetry Remote Sensing and Spatial Information Sciences, XLII-2/W11*, 2019, pp. 141–148, <https://doi.org/10.5194/isprs-archives-XLII-2-W11-141-2019>.
- [48] F. Banfi, HBIM generation: Extending geometric primitives and BIM; modelling tools for heritage structures and complex vaulted systems, in: *ISPRS - International Archives of Photogrammetry Remote Sensing and Spatial Information Sciences, XLII-2/W15*, 2019, pp. 139–148, <https://doi.org/10.5194/isprs-archives-XLII-2-W15-139-2019>.
- [49] L. Barazzetti, F. Banfi, R. Brumana, M. Previtali, Creation of parametric BIM objects from point clouds using NURBS, *Photogramm. Rec.* 30 (152) (2015) 339–362, <https://doi.org/10.1111/phor.12122>.
- [50] A. Grazzini, M. Zerbinatti, Static and seismic behaviour of different dry stone wall textures, in: G. Milani, A. Taliervo, S. Garrity (Eds.), *Proc. of 10<sup>th</sup> International Masonry Conference, Milan, Italy, The International Masonry Society (IMS), Whyteleaf (UK)*, 9–11 July 2018, pp. 1088–1102 (ISSN 2523-532X).