

Multiband Tunable FSS structure with using feeding network microstrip lines based on Microwave Circuit

Original

Multiband Tunable FSS structure with using feeding network microstrip lines based on Microwave Circuit / Mir, Farzad; De Sabata, Aldo; Matekovits, Ladislau. - ELETTRONICO. - (2022), pp. 1-4. (2022 3rd URSI Atlantic and Asia Pacific Radio Science Meeting (AT-AP-RASC) Gran Canaria, Spain 30 May 2022 - 04 June 2022) [10.23919/AT-AP-RASC54737.2022.9814323].

Availability:

This version is available at: 11583/2969962 since: 2022-07-25T09:17:14Z

Publisher:

IEEE

Published

DOI:10.23919/AT-AP-RASC54737.2022.9814323

Terms of use:

This article is made available under terms and conditions as specified in the corresponding bibliographic description in the repository

Publisher copyright

IEEE postprint/Author's Accepted Manuscript

©2022 IEEE. Personal use of this material is permitted. Permission from IEEE must be obtained for all other uses, in any current or future media, including reprinting/republishing this material for advertising or promotional purposes, creating new collecting works, for resale or lists, or reuse of any copyrighted component of this work in other works.

(Article begins on next page)



Multiband Tunable FSS structure with using feeding network microstrip lines based on Microwave Circuit

Farzad Mir¹⁺, Aldo De Sabata^{2*}, and Ladislau Matekovits^{3+*#}

⁺Department of Electronics and Telecommunications, Politecnico di Torino, Turin, Italy

^{*}Department of Measurements and Optical Electronics, University Politehnica Timisoara, 300223 Timisoara, Romania

[#]Istituto di Elettronica e di Ingegneria dell'Informazione e delle Telecomunicazioni, National Research Council of Italy, 10129 Turin, Italy

farzad.mir@studenti.polito.it ¹, aldo.de-sabata@upt.ro ², ladislau.matekovits@polito.it ³

Abstract

Design and analysis of a miniaturized tunable periodic structure using PIN diodes is presented. The behaviour of the structure for two different incidences of electromagnetic waves, namely TE and TM incidences, is reported in the frequency range between 2 and 14 GHz. To achieve a proper way to overcome the problems introduced by the biasing of the lumped elements, biasing microstrip lines have been designed. Special care in the design had to focus on the symmetry breaking introduced by the feeding lines. The proposed tunable metasurface exhibits broadband and multiband frequency response.

1 Introduction

Frequency Selective Surfaces (FSS) are a special case of metasurfaces exhibiting spatial filtering features in a certain frequency range. Usually, such structures consist of 2D periodic repetition of a unit-cell to form an array, which is exposed to an incident electromagnetic wave [1–3]. FSSs are 2D metamaterials which, by special geometrical design allow for obtaining planar structures with properties not available from traditional materials. Moreover, by incorporating electronic devices, FSSs can achieve controllable properties. These structures behave as low-pass, high-pass, band-pass, etc. filters that reflect, absorb, or transmit the electromagnetic (EM) waves in a requested frequency range [4]. Among the various ways of categorizing them, FSSs can be classified in the resonator group, so they have resonant characteristic as capacitor and inductor. When the FSS structure behaves as high-pass or band-stop it can be considered to have a capacitive response, while the inductive response is for FSSs with low-pass or band-pass filtering behavior [5]. Currently, FSS structures are widely used in different applications such as: (i) lower radar cross-section, (ii) radomes, (iii) reduce coupling among antennas, and others, as for example in microwave stoves.

In some advanced applications, e.g., security enhancement, tracking, etc., tunability of the operational frequency range

is required, hence nowadays designers are looking for various solutions to fulfill these challenges. Thus, the idea of tunable FSS structures is enforced e.g., [6, 7]. To design such tunable configurations, usually lumped elements are required.

The main purpose of this work is to design a tunable FSS structure. PIN and varactor diodes are both qualified to be used [8]. Both solutions present different advantages and drawbacks. PIN diodes have been selected in the present investigation. In the numerical study, realistic models have been considered for the diodes. In the ON state, an open-circuit (mainly capacitive) model, and in OFF state, a short circuit one, which corresponds to a resistive character have been applied [9].

To bias these lumped elements, a DC biasing network is required. Its presence in the structure alters the electromagnetic response of the initial configuration. Consequently, during the design process, the existence of the biasing network should be thoroughly considered. Proper location of the biasing lines is challenging. In the proposed configuration, a solution based on microwave circuits has been considered, by using microstrip lines. These lines are running parallel to some other printed elements within the unit cells, so their effects are strongly reduced.

In detail, the proposed structure consists of two circles and two crossed microstrip lines disposed such that the unit cell exhibits two symmetry planes. Also, for inserting the PIN diodes, four cut-slots are created in the microstrip lines on the surface of the board. The feed network lines are placed on the opposite side of the dielectric supporting the main FSS structure, aiming to reduce its effect on the transmitted/reflected electromagnetic waves.

This paper is organized as follows: the design of the structure and models for the diodes, including nominal values for both ON and OFF states are presented in second section. Section 3 illustrates the operation of the proposed FSS structure. Conclusions are detailed in the last section.

2 Description of the geometry and of the lumped element model of the diodes

This section provides the information about the FSS structure shown in Fig. 1 and positioning strategy of the diodes, and their biasing mechanism. Moreover, the models for the ON and OFF states of the diodes are discussed.

The proposed structure has been implemented on FR-4 substrate ($\epsilon_r = 4.3$ and $\tan \delta = 0.025$). The thickness of substrate 1 is $h_1 = 1.58$ mm while for the second dielectric (substrate 2), the layer thickness is 0.8 mm. Substrate 2 is placed between two microstrip lines and the main structure, while substrate 1 separates the two biasing lines introduced in Fig. 2. The values for other dimensions of the structure are as follows: $D_u = D_v = 14$ mm, $L = 12$ mm, $W = 0.5$ mm, $R_1 = 6$ mm and $R_2 = 3$ mm.

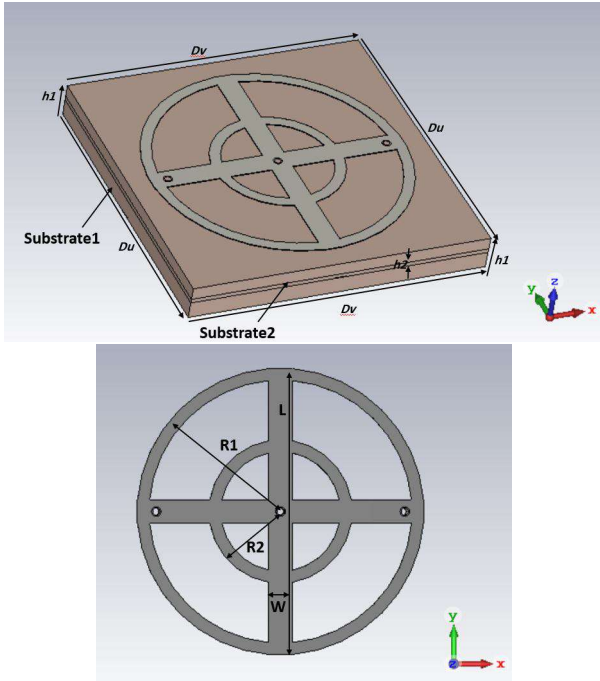

Figure 1. Schematic of the proposed unit-cell with indication of the leading dimensions: perspective (top) and top-view - with removed dielectric layers (bottom)

Two microstrip lines having the role of bringing the DC bias to the diodes clamps have dimensions of $L_m = 14$ mm and $W_m = 0.5$ mm. One of the lines is rotated with respect to the other by 90° and it is located on a different layer to avoid short circuit between them. Also in Fig. 2 the connection between the main FSS structure at surface and two DC bias lines is reported. Via-holes dimensions are $R_{out} = 0.2$ mm (standing for the outer radius of a cylinder shape) and $R_{in} = 0.15$ mm (inner radius). The distance of the edge of the structure from via-holes located on the left and right sides of the structure is $op_1 = 1.8$ mm and the distance of center via-hole is $op_2 = 7$ mm.

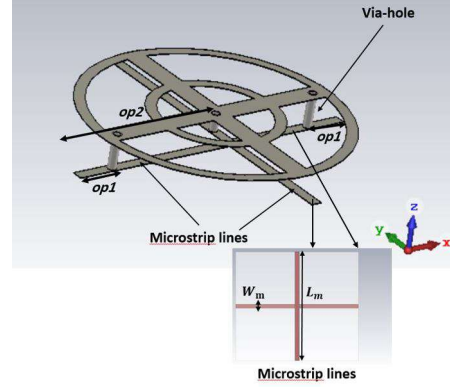

Figure 2. FSS structure with via-hole.

To insert diodes into the structure, four cut-slots are created, as shown in Fig. 3.

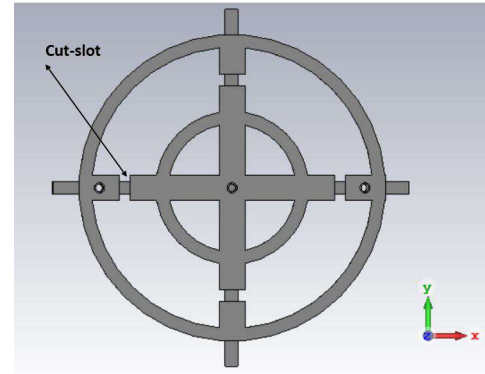

Figure 3. FSS structure with cut-slot.

As anticipated, PIN diodes are used in this work (MADP-000907-14020, Macom Technology). They operate in two different conditions, namely ON and OFF-state as it is shown in Fig. 4. The equivalent circuit of diode in both ON-state which corresponds to small resistance R and OFF-state indicating capacitive behavior is presented in Fig. 4. The considered PIN diode works up to a maximum frequency of 40 GHz.

The nominal values for the RL circuit (ON-state) condition are $R = 7.8 \Omega$ and $L = 30$ pH. When the PIN diode behaves as RC circuit, the value for the elements are $R = 30$ k Ω and $C_s = 28$ fF.

3 Simulation Results

This section reports the analysis results of the proposed FSS carried out in CST software tool. Periodic boundary conditions and Floquet ports have been employed, considering the single unit cell. Moreover, the frequency range has been set from 2 to 14 GHz. The results are reported for two different incidences, TE and TM respectively. Also, the transmission coefficient is plotted for normal incidence ($\theta = 0$ and $\phi = 0$).

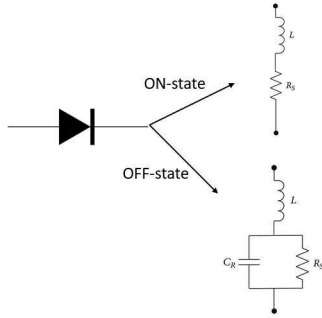
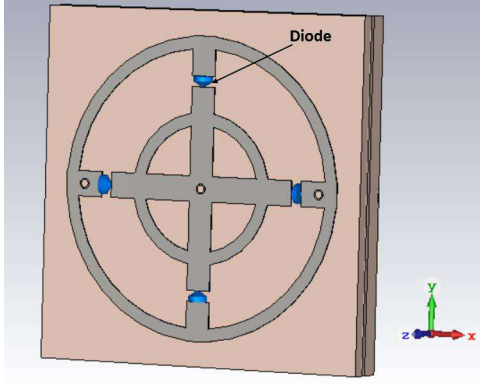

Figure 4. FSS structure with diodes (top), Diode schematic (bottom)

First plot Fig. 5 refers to analyzing the main structure in both TE (top) and TM (bottom) incidence. According to TE incidence shown in Fig. 5 (top), the structure has two frequency bands. A first band-stop is between 6.68 and 9.44 GHz with -34.11 dB attenuation level. A second -10 dB band-stop is from 11.7 to 12.44 GHz (-19.82 dB attenuation). The result for TM incidence in Fig. 5 (bottom) has only one frequency band, which covers the frequency range 2.51 GHz (9.83 - 12.34 GHz), and its notch frequency occurs at 11.21 GHz, having -31.88 dB transmittance level.

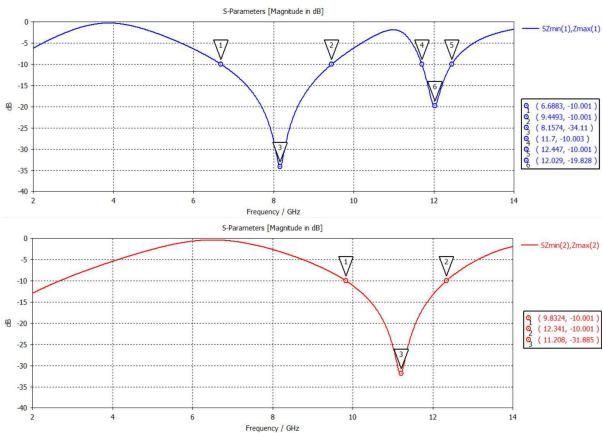

Figure 5. TE incidence for main structure (top), TM incidence for main structure (bottom).

After the application of the cut-slots in the structure, the transmission curves are modified as reported in Fig. 6 for both TE and TM incidence. There are two frequency bands of interest in structure with cut-slots. The first -10 dB band-stop is between 4.34 and 6.18 GHz, which has a notch at 5.14 GHz with -35.14 dB attenuation level. Also, the second one is between 9.92 and 10.25 GHz (-14.26 dB). In TM incidence, two band-stop frequency ranges exist. A first one covers 210 MHz with transmittance level of -14.25 dB, while the second frequency band is between 12.21 and 14.04 GHz with a frequency notch at 13.33 GHz (-26.01 dB).

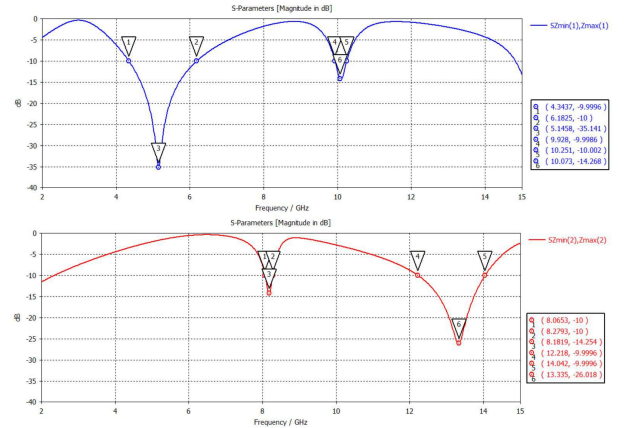

Figure 6. TE incidence for cut-slot structure (top), TM incidence for cut-slot structure (bottom).

ON-state condition is illustrated in Fig. 7. The first frequency band at TE incidence (Fig. 7 top) is from 6.60 to 9.44 GHz (attenuation level is -26.74 dB at 8.13 GHz) and the second one covers 11.69 - 12.32 GHz with -13.27 dB transmittance level at 12.01 GHz. For TM incidence, the -10 dB stop-band is between 9.78 and 12.31 GHz with -24.98 dB attenuation level. Contrarily, the result for OFF state in TE incidence in Fig. 8 (top) indicates that the frequency of attenuation moves to 5.6 GHz (4.34 - 6.18 GHz.). In TM incidence, as shown in Fig. 8 (bottom), the large band-stop is from 12.24 to 14.04 GHz with a transmittance level (-25.71 dB) at 13.33 GHz.

4 Conclusion

The main purpose of this paper has been to design a multi-band structure which is able to be tuned by applying PIN diodes. Then, for tackling the problem of biasing the non-linear elements (increasing the complexity of the structure) by using DC bias network, a new configuration has been proposed, based on microwave circuits. According to this method, two microstrip lines have been designed as a feeding network. The FSS structure proposed in this paper covers S, C, X, and Ku frequency bands. Moreover, this structure has been built on cost-effective FR-4 substrate. Four cut-slots have been created in the structure for the insertion of the PIN diodes. The PIN diodes operate in two states: *i*:

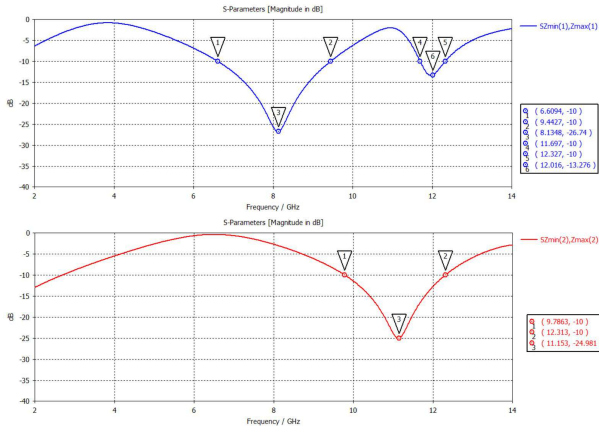

Figure 7. TE incidence for diode structure (ON-state) (top), TM incidence for diode structure (ON-state) (bottom).

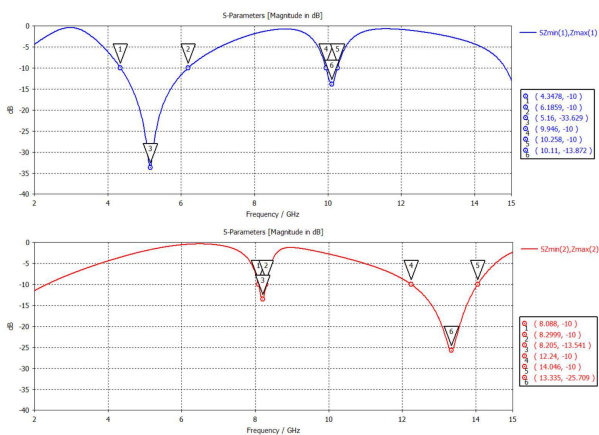

Figure 8. TE incidence for diode structure (OFF-state) (top), TM incidence for diode structure (OFF-state) (bottom).

ON-state (shows capacity characteristic) and *ii*: OFF-state which is modelled by a resistance feature. Also, the results of analyzing the FSS structure have been illustrated in both TE and TM incidence of electromagnetic wave.

References

- [1] B. Munk, "Frequency selective surfaces: Theory and design [book review]," *IEEE Circuits and Devices Magazine*, vol. 21, no. 1, pp. 36–36, 2005.
- [2] F. Mir, L. Matekovits, and A. De Sabata, "Symmetry-breaking manipulation in the design of multifunctional tunable frequency selective surface," *AEU - International Journal of Electronics and Communications*, vol. 142, p. 154003, 2021. [Online]. Available: <https://www.sciencedirect.com/science/article/pii/S1434841121004003>
- [3] L. Matekovits, "Analytically expressed dispersion diagram of unit cells for a novel type of holographic surface," *IEEE Antennas and Wireless Propagation Letters*, vol. 9, pp. 1251–1254, 2010.

- [4] L. Sun, H. Cheng, Y. Zhou, and J. Wang, "Broadband metamaterial absorber based on coupling resistive frequency selective surface," *Opt. Express*, vol. 20, no. 4, pp. 4675–4680, Feb 2012. [Online]. Available: <http://www.opticsexpress.org/abstract.cfm?URI=oe-20-4-4675>
- [5] X. Yao, B. Liang, and M. Bai, "Quasi-optical frequency selective surface with phase compensation structure correcting the beam distortion," *Opt. Express*, vol. 25, no. 19, pp. 23 014–23 023, Sep 2017. [Online]. Available: <http://www.opticsexpress.org/abstract.cfm?URI=oe-25-19-23014>
- [6] X. Chen, J. Gao, C. Fang, N. Xu, Y. Wang, and Y. Tang, "Deformable frequency selective surface structure with tuning capability through thermoregulating," *Opt. Express*, vol. 23, no. 12, pp. 16 329–16 338, Jun 2015. [Online]. Available: <http://www.opticsexpress.org/abstract.cfm?URI=oe-23-12-16329>
- [7] L. Matekovits, A. De Sabata, and K. P. Esselle, "Effects of a coplanar waveguide biasing network built into the ground plane on the dispersion characteristics of a tunable unit cell with an elliptical patch and multiple vias," *IEEE Antennas and Wireless Propagation Letters*, vol. 10, pp. 1088–1091, 2011.
- [8] M. Kiani, M. Tayarani, A. Momeni, H. Rajabalipanah, and A. Abdolali, "Self-biased tri-state power-multiplexed digital metasurface operating at microwave frequencies," *Opt. Express*, vol. 28, no. 4, pp. 5410–5422, Feb 2020. [Online]. Available: <http://www.opticsexpress.org/abstract.cfm?URI=oe-28-4-5410>
- [9] M. Kiani, A. Momeni, M. Tayarani, and C. Ding, "Spatial wave control using a self-biased nonlinear metasurface at microwave frequencies," *Opt. Express*, vol. 28, no. 23, pp. 35 128–35 142, Nov 2020. [Online]. Available: <http://www.opticsexpress.org/abstract.cfm?URI=oe-28-23-35128>